



US00D891336S

(12) **United States Design Patent** (10) **Patent No.:** **US D891,336 S**
Bering et al. (45) **Date of Patent:** **** Jul. 28, 2020**

(54) **FENDER FOR WORK VEHICLE**

DESCRIPTION

(71) Applicant: **Deere & Company**, Moline, IL (US)
(72) Inventors: **Christopher A. Bering**, Dike, IA (US);
Joshua J. Kappelman, Cedar Falls, IA (US); **Amol Adsul**, Pune (IN); **Jeremy P. L'Heureux**, Cedar Falls, IA (US)
(73) Assignee: **DEERE & COMPANY**, Moline, IL (US)
(**) Term: **15 Years**
(21) Appl. No.: **29/680,650**
(22) Filed: **Feb. 19, 2019**
(51) **LOC (12) Cl.** **12-16**
(52) **U.S. Cl.**
USPC **D12/184**
(58) **Field of Classification Search**
USPC D12/90-93, 96, 163, 164, 171, 181, 184, D12/196

FIG. 1 is a rear perspective view of a fender for work vehicle according to one embodiment of our new design; FIG. 2 is an enlarged rear perspective view thereof; FIG. 3 is a front elevation view thereof; FIG. 4 is a rear elevation view thereof; FIG. 5 is a first side elevation view thereof; FIG. 6 is a second side elevation view thereof; FIG. 7 is a top plan view thereof; FIG. 8 is a bottom plan view thereof; FIG. 9 is an enlarged rear perspective view thereof shown with a symbolic break in width; FIG. 10 is a front elevation view thereof; FIG. 11 is a rear elevation view thereof; FIG. 12 is a first side elevation view thereof; FIG. 13 is a second side elevation view thereof; FIG. 14 is a top plan view thereof; FIG. 15 is a bottom plan view thereof; FIG. 16 is a rear perspective view of a fender for work vehicle according to another embodiment of our new design; FIG. 17 is an enlarged rear perspective view thereof; FIG. 18 is a front elevation view thereof; FIG. 19 is a rear elevation view thereof; FIG. 20 is a first side elevation view thereof; FIG. 21 is a second side elevation view thereof; FIG. 22 is a top plan view thereof; FIG. 23 is a bottom plan view thereof; FIG. 24 is an enlarged rear perspective view thereof shown with a symbolic break in width; FIG. 25 is a front elevation view thereof; FIG. 26 is a rear elevation view thereof; FIG. 27 is a first side elevation view thereof; FIG. 28 is a second side elevation view thereof; FIG. 29 is a top plan view thereof; and, FIG. 30 is a bottom plan view thereof. FIGS. 1-30 illustrate the fender for work vehicle for on a left side of an example work vehicle when viewed from the perspective of FIGS. 1 and 16. The fender for work vehicle may be on the right side of a work vehicle and will be understood to be viewed as mirror images of the views shown in FIGS. 2-15 and 17-30.

(Continued)

(56) **References Cited**

U.S. PATENT DOCUMENTS

D344,059 S * 2/1994 DeBaal D12/184
D347,614 S * 6/1994 DeBaal D12/184
(Continued)

OTHER PUBLICATIONS

John Deere, 9R/9RT/9RX Series Tractors Brochure, "The New Power of Choice", Sep. 2017.

Primary Examiner — George D. Kirschbaum
Assistant Examiner — Joseph J Kukella
(74) *Attorney, Agent, or Firm* — Klintworth & Rozenblat IP LLP

(57) **CLAIM**

The ornamental design for a fender for work vehicle, as shown and described.

(Continued)

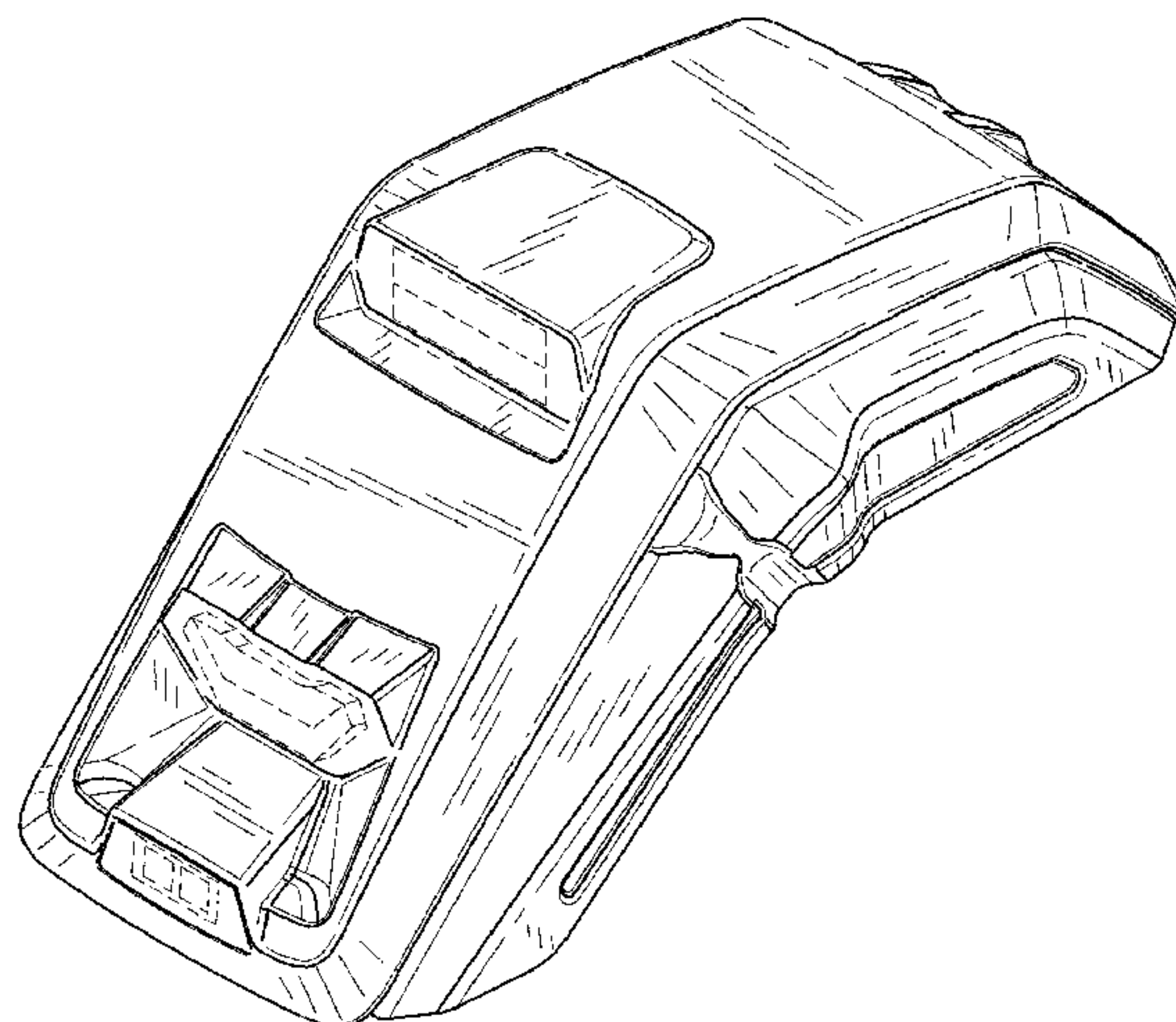

The evenly dashed lines in the figures depict environmental features and portions of the article that form no part of the claimed design. The unevenly dashed lines represent a symbolic break across the width of the article and the appearance of any portion of the article between these break lines forms no part of the claimed design.

1 Claim, 18 Drawing Sheets

(58) **Field of Classification Search**

CPC B62D 25/02; B62D 25/04; B62D 25/10;
B62D 25/105; B62D 25/16; B62D
25/161; B62D 25/168; B60J 5/00; B60J
5/02; B60J 5/04; B60J 5/10

See application file for complete search history.

(56) **References Cited**

U.S. PATENT DOCUMENTS

D545,255 S *	6/2007	Angelo	D12/173
D621,756 S *	8/2010	Angelo	D12/184
D623,103 S *	9/2010	Braga	D12/181
D699,650 S *	2/2014	Peltola	D12/184
D699,651 S *	2/2014	Peltola	D12/184
D712,324 S *	9/2014	McFarlin	D12/181
D778,795 S *	2/2017	Johns	D12/184
D839,806 S *	2/2019	Chi	D12/184
D855,519 S *	8/2019	Bundy	D12/184
D863,159 S *	10/2019	Goodrich	D12/184
D870,620 S *	12/2019	Hallgren	D12/184

* cited by examiner

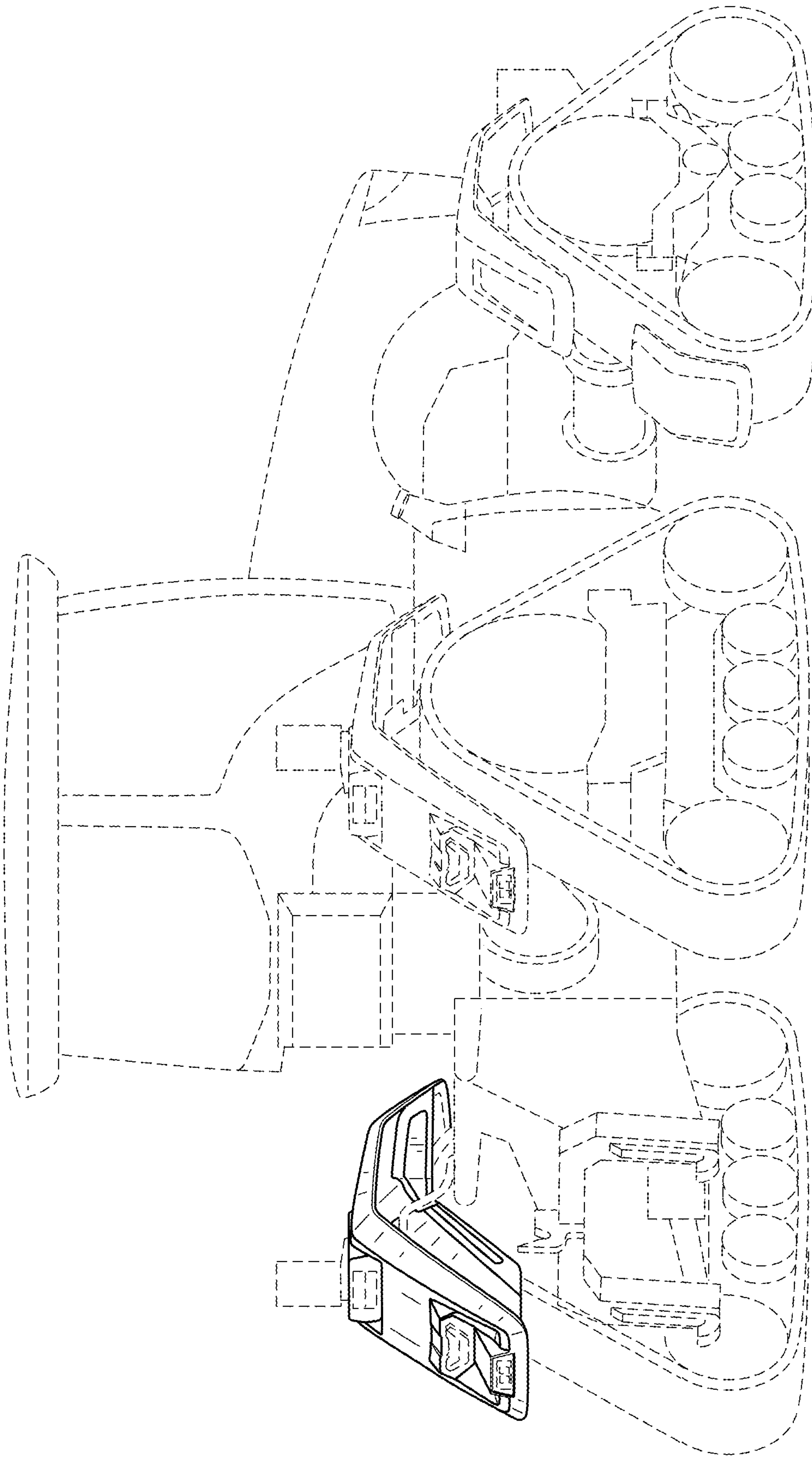

FIG. 1

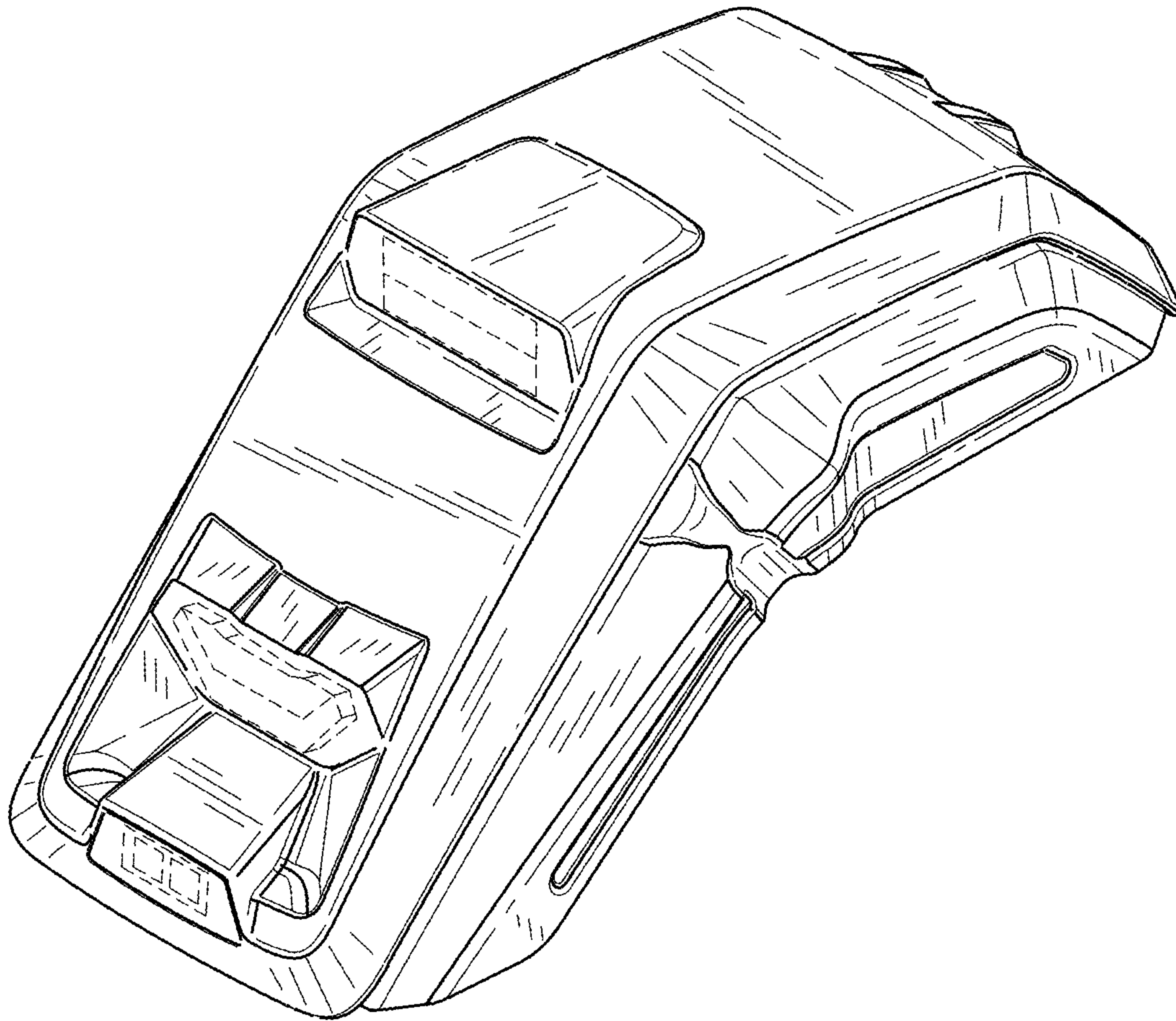

FIG. 2

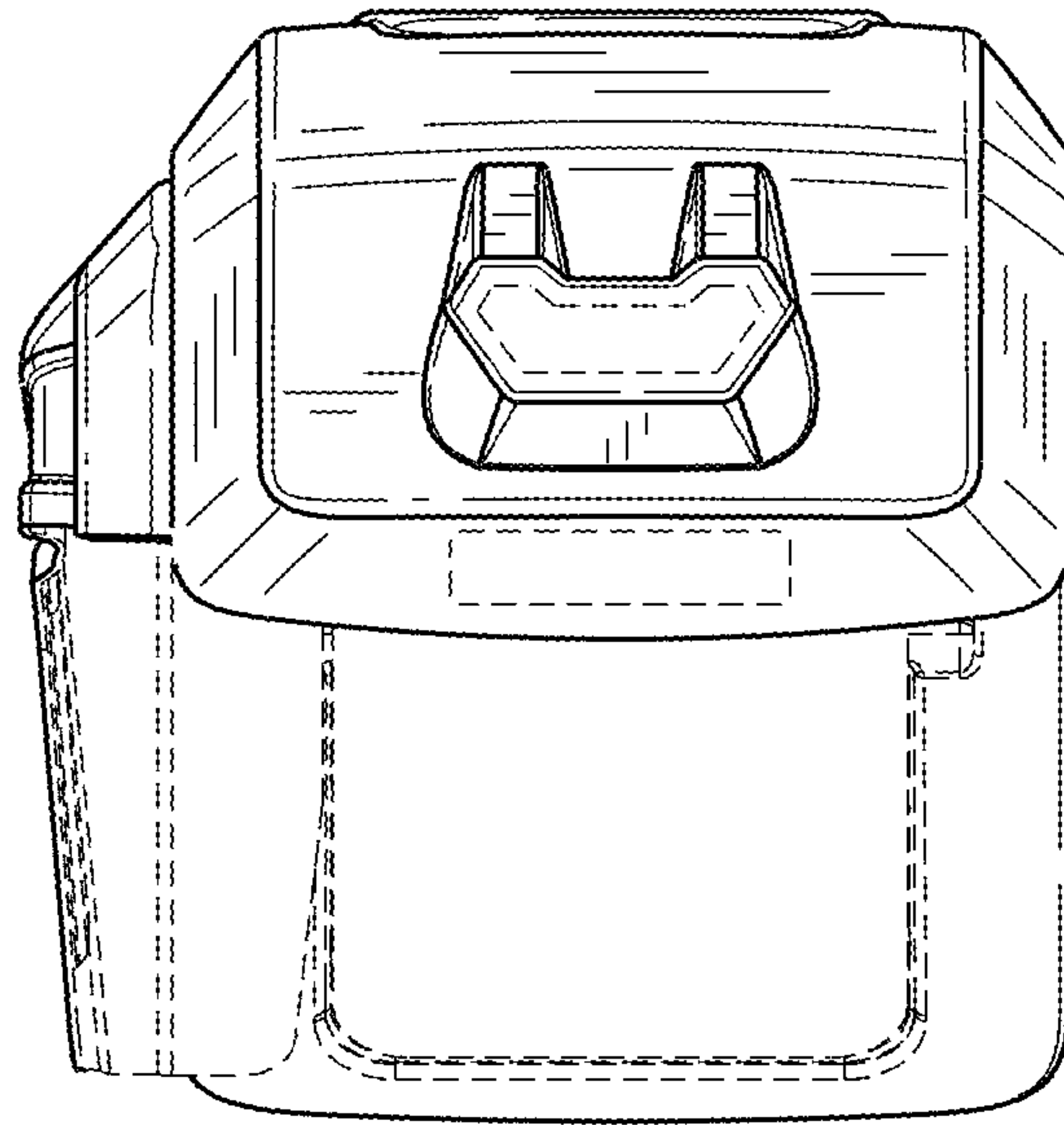

FIG. 3

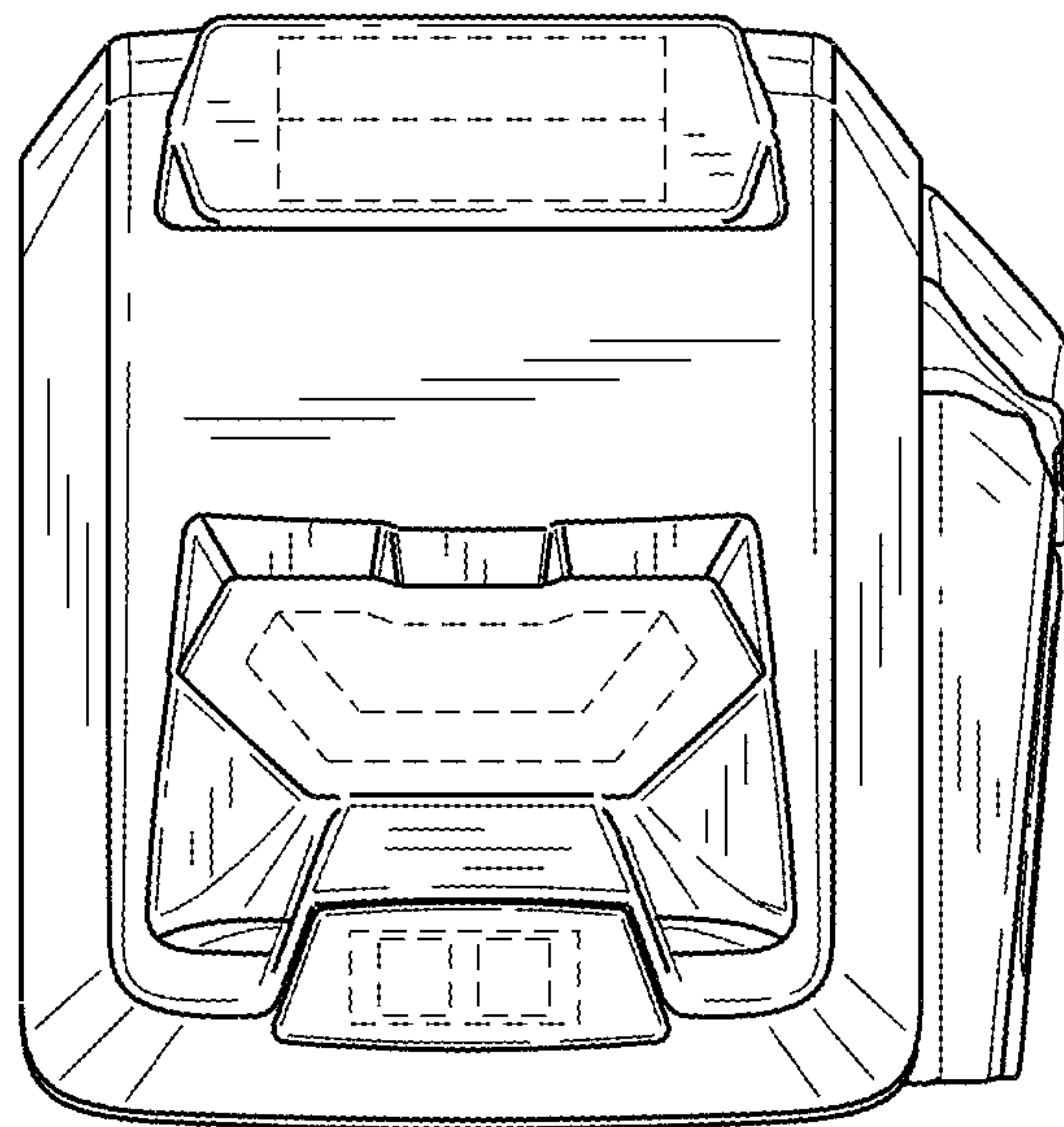

FIG. 4

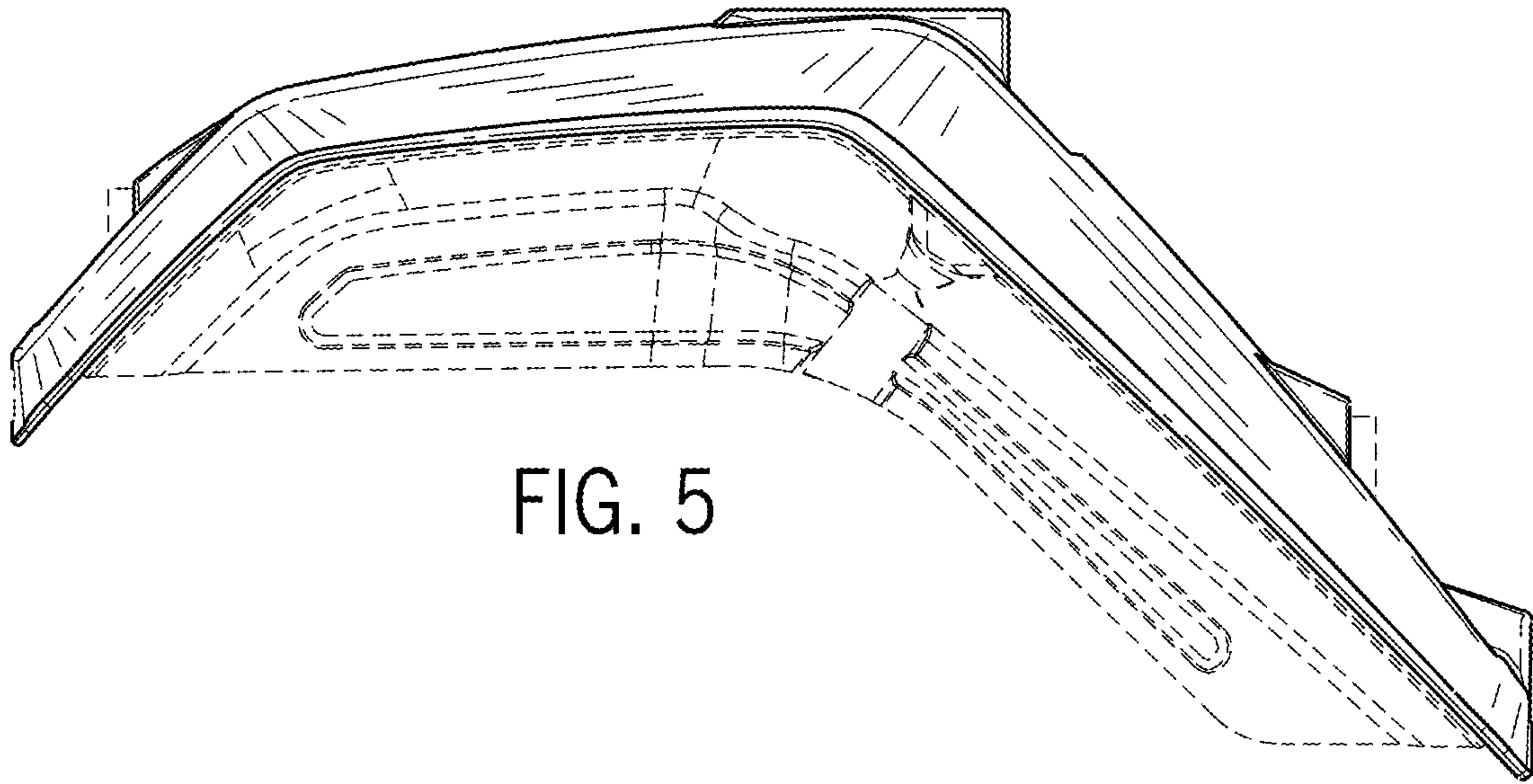

FIG. 5

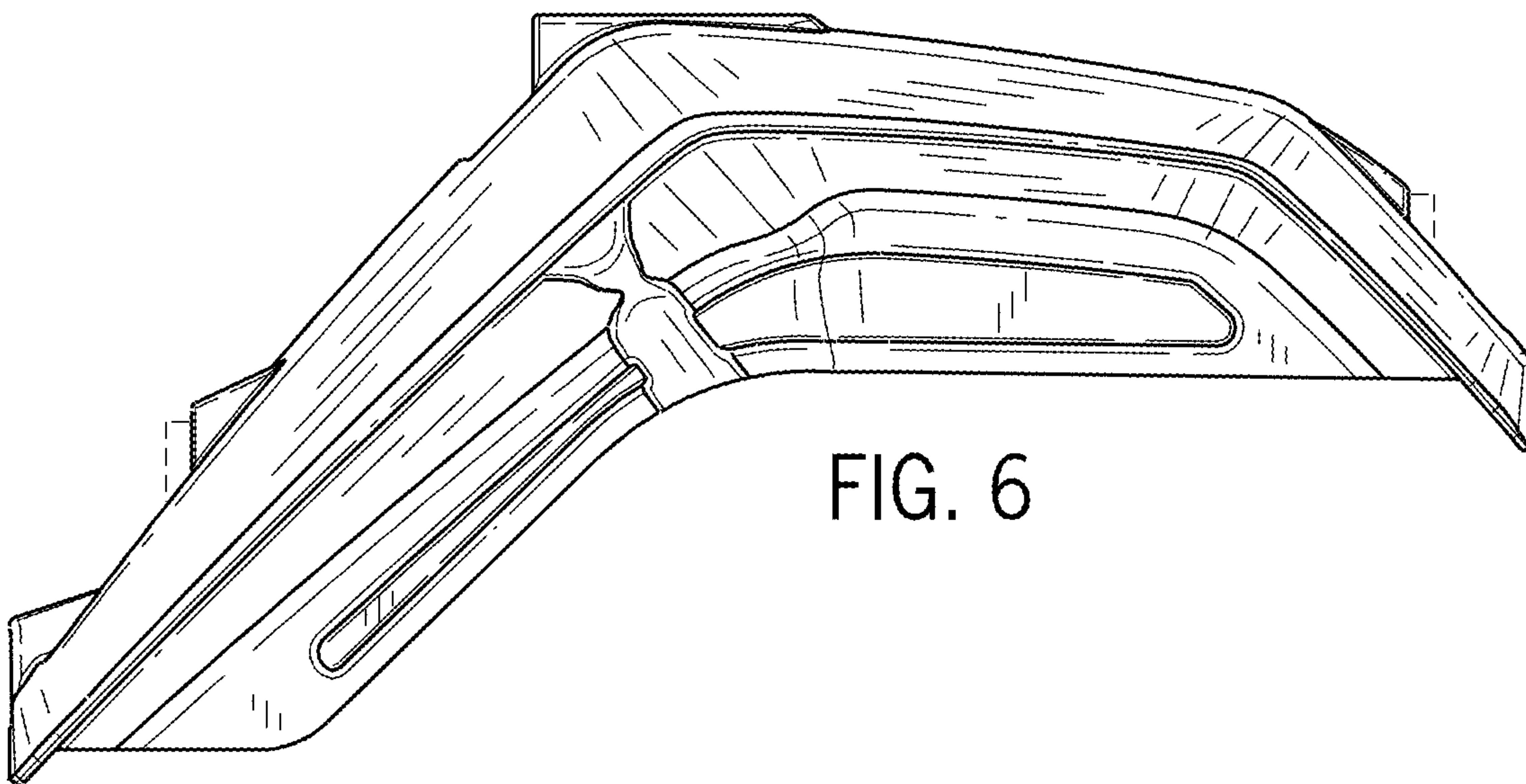

FIG. 6

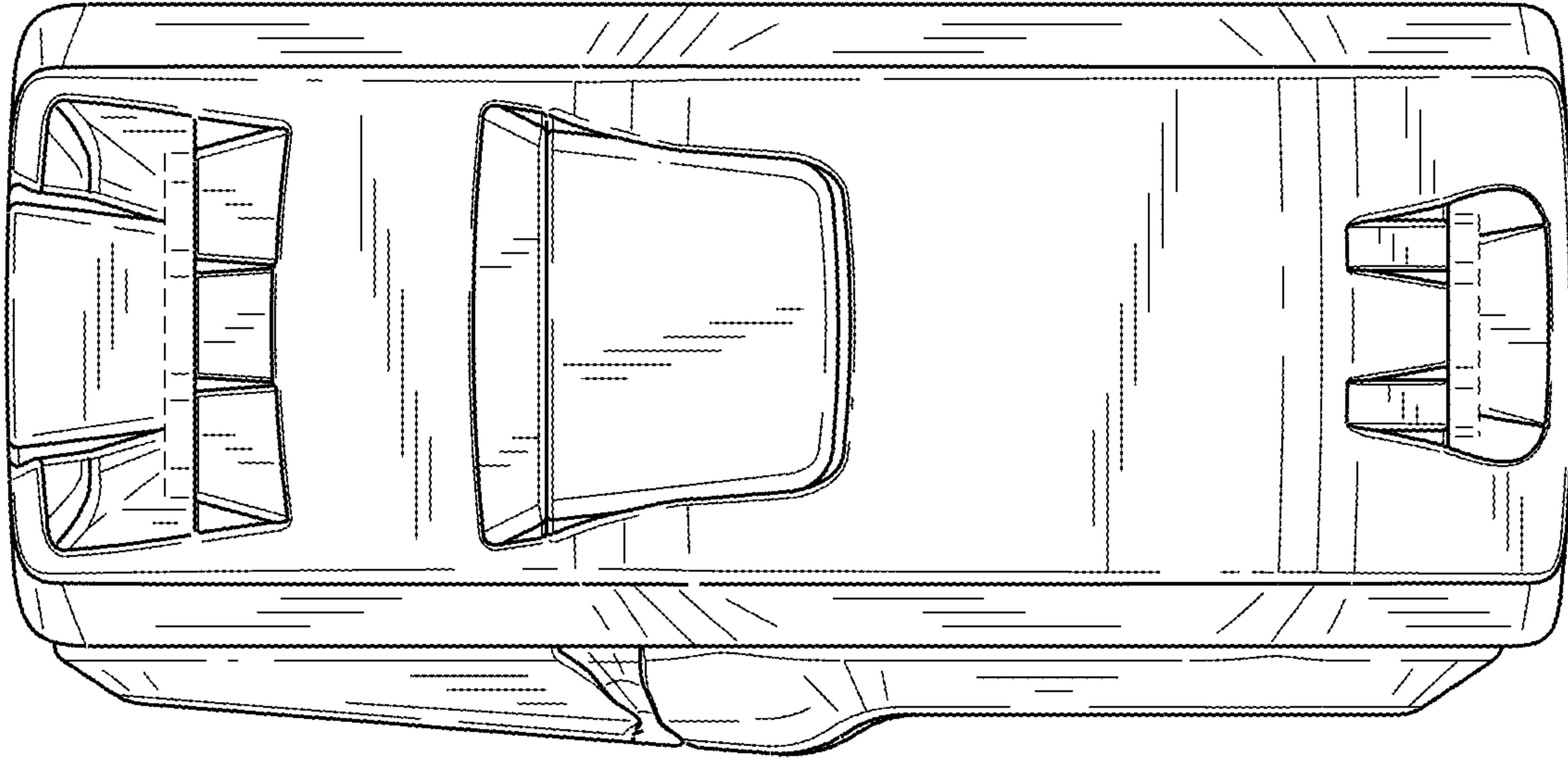

FIG. 7

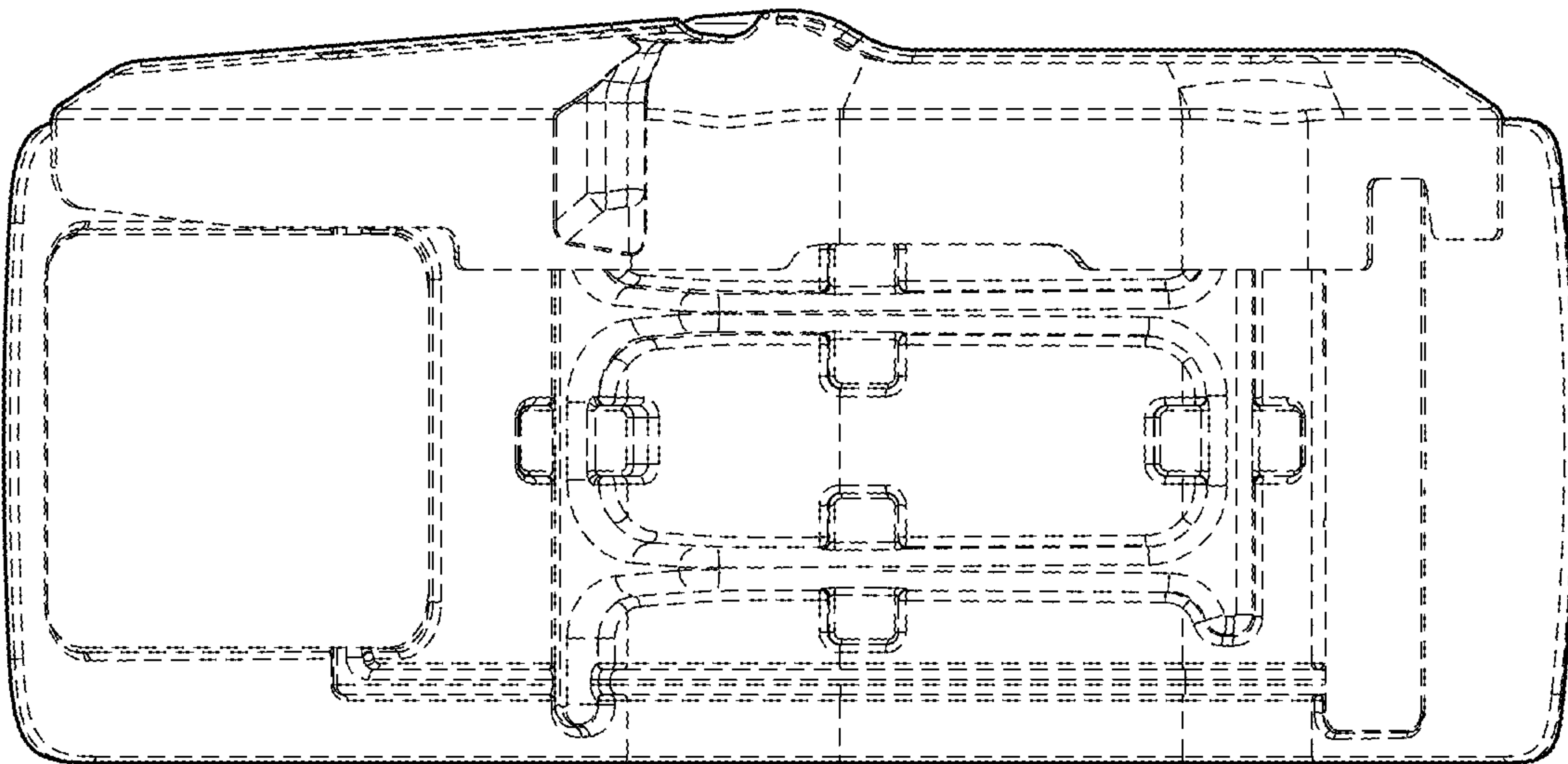

FIG. 8

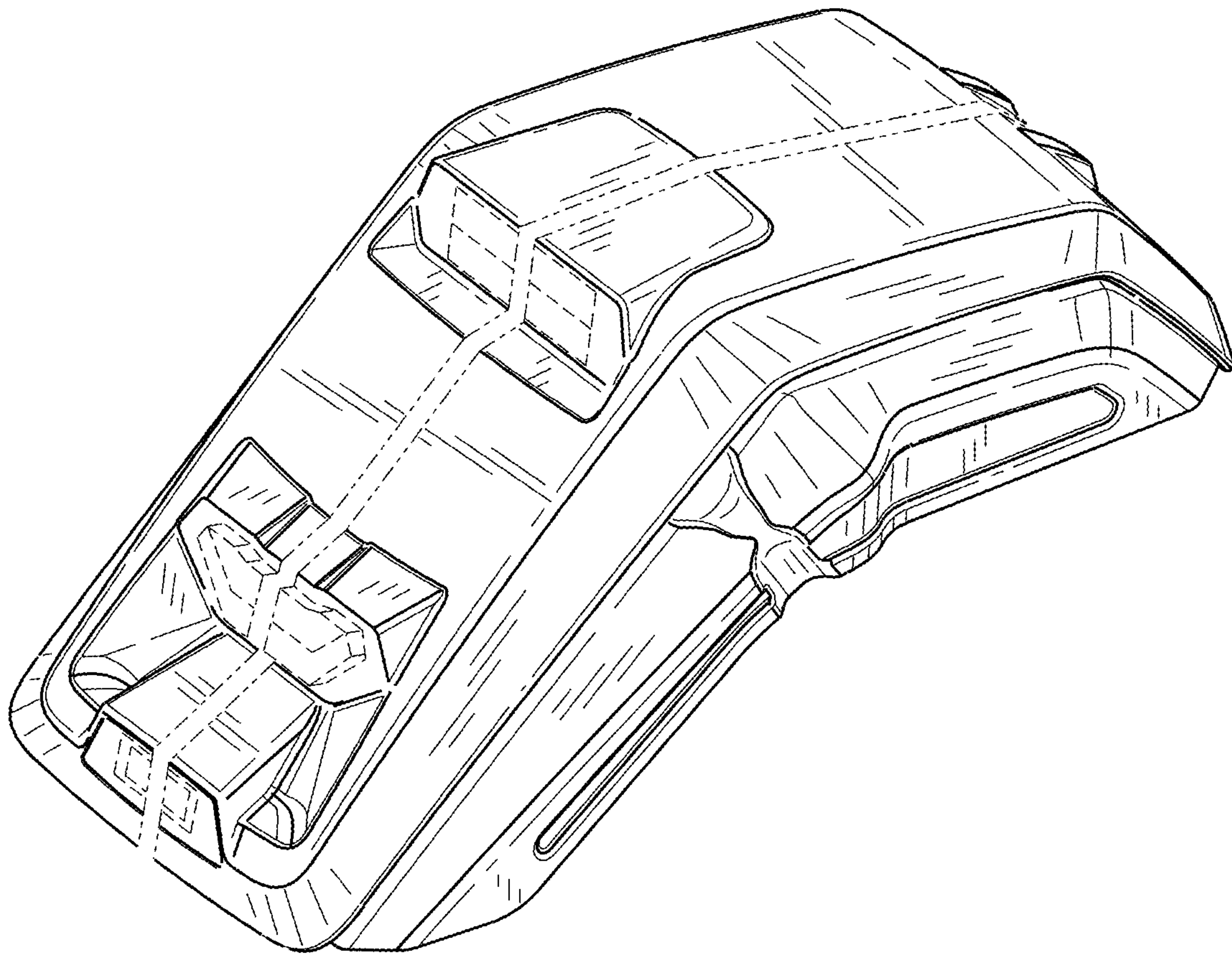

FIG. 9

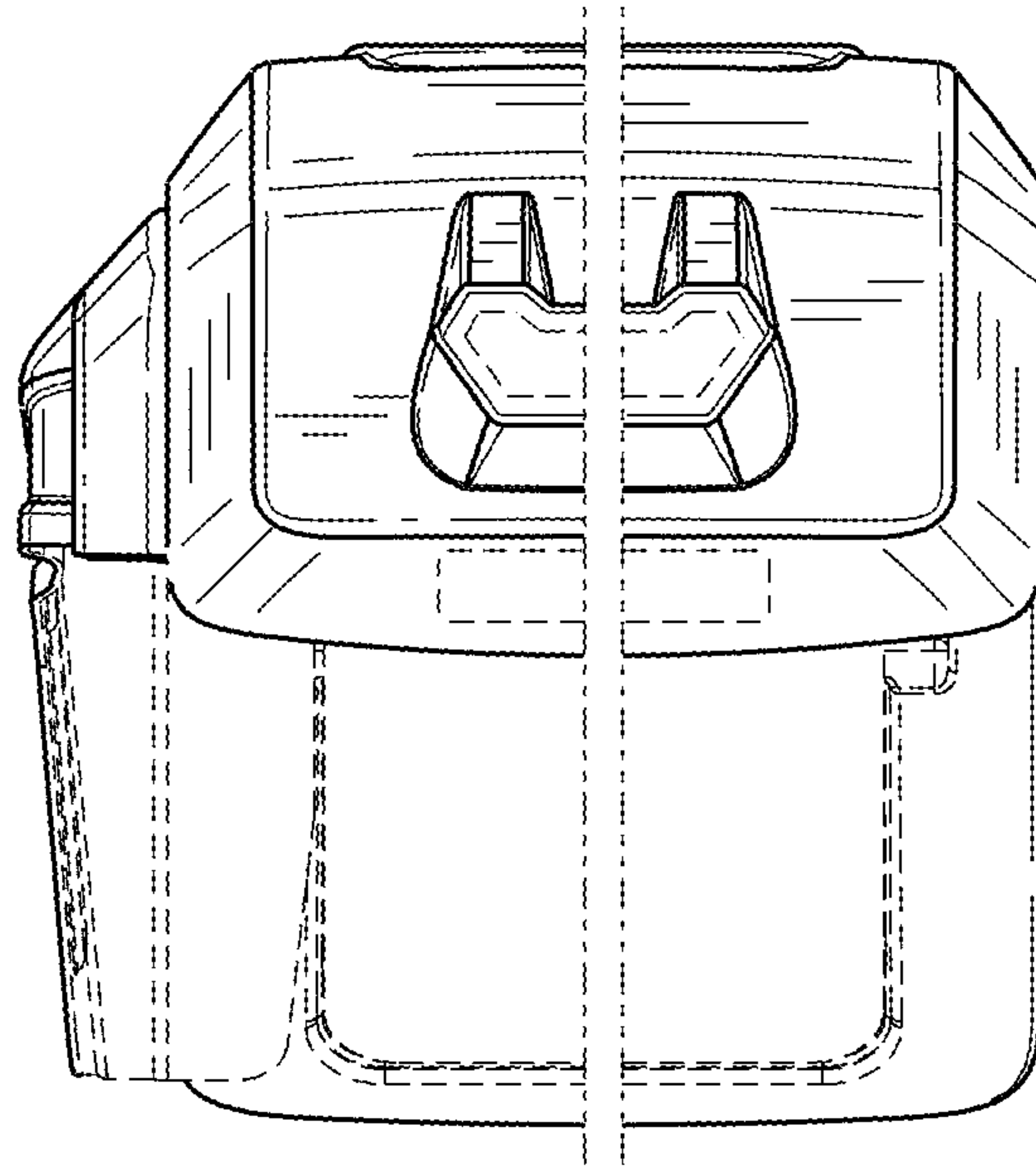

FIG. 10

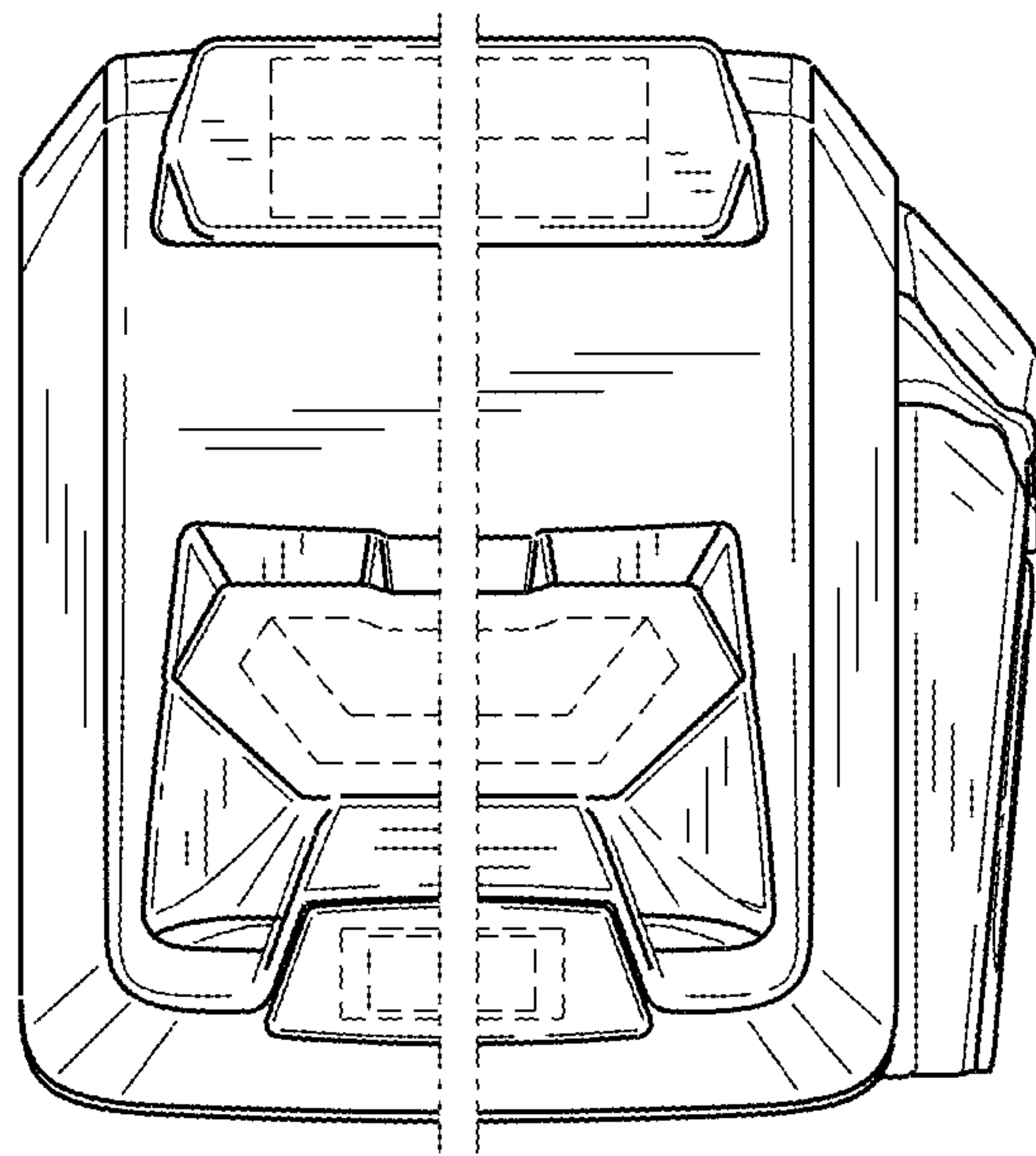

FIG. 11

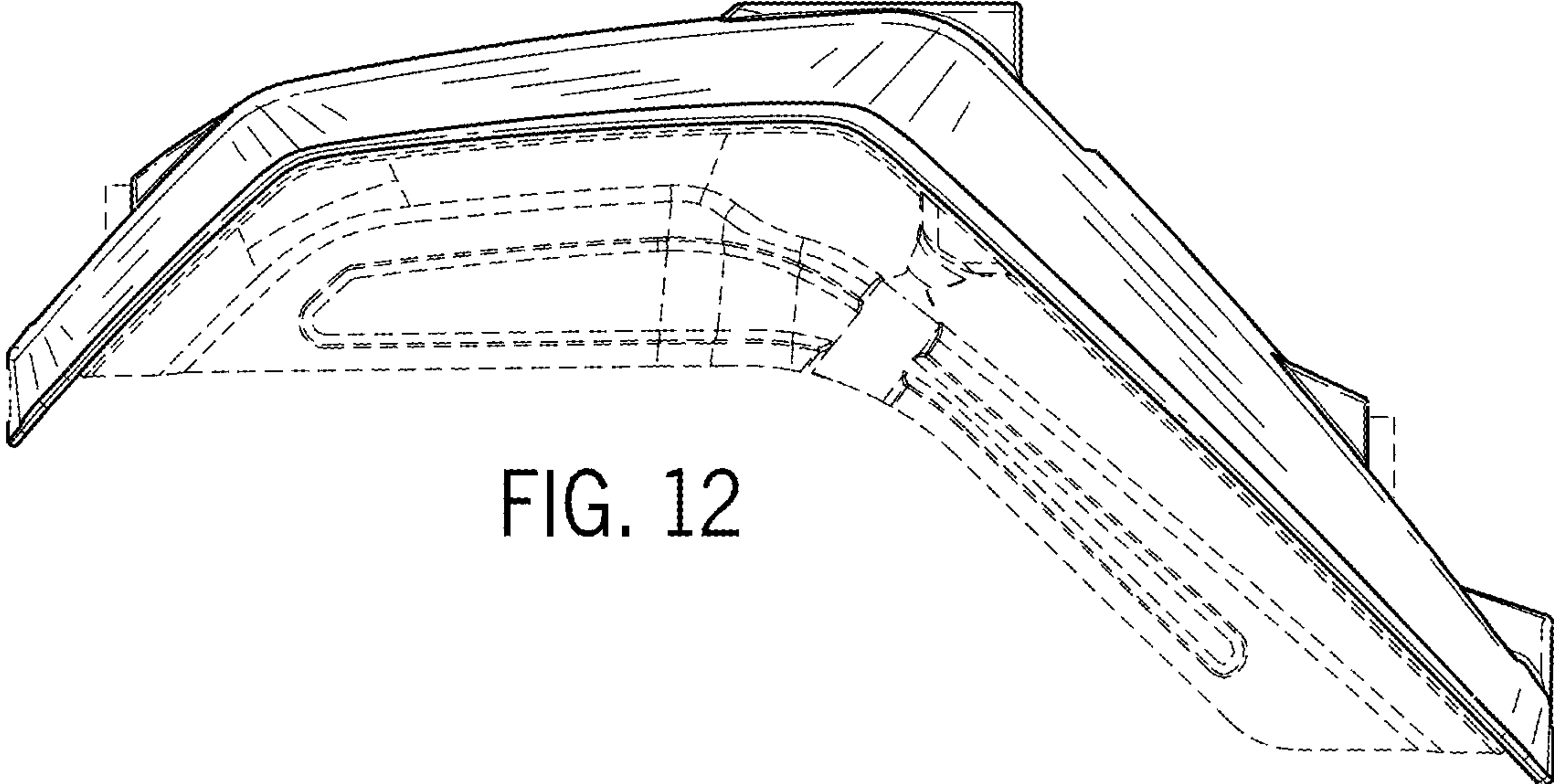

FIG. 12

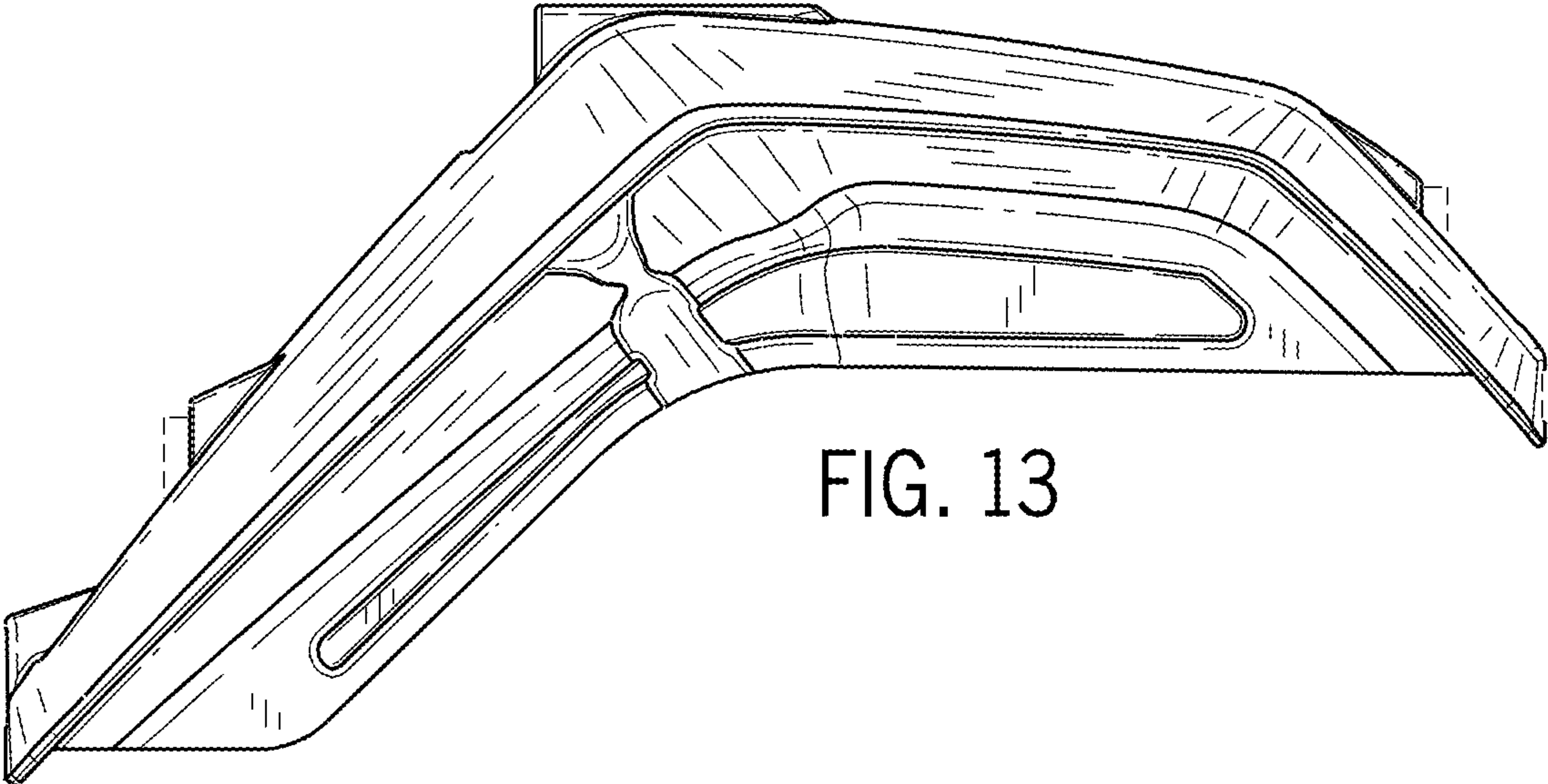

FIG. 13

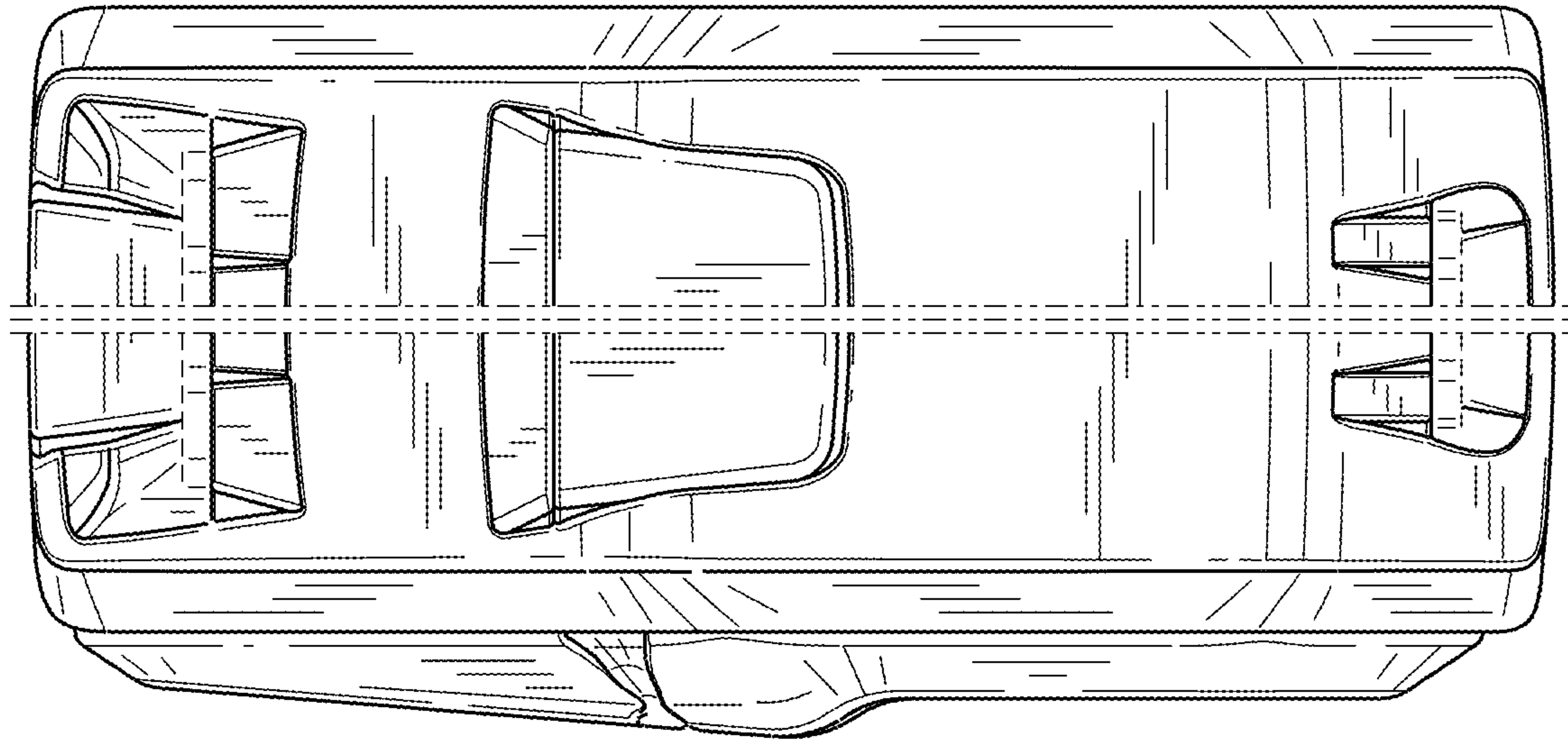

FIG. 14

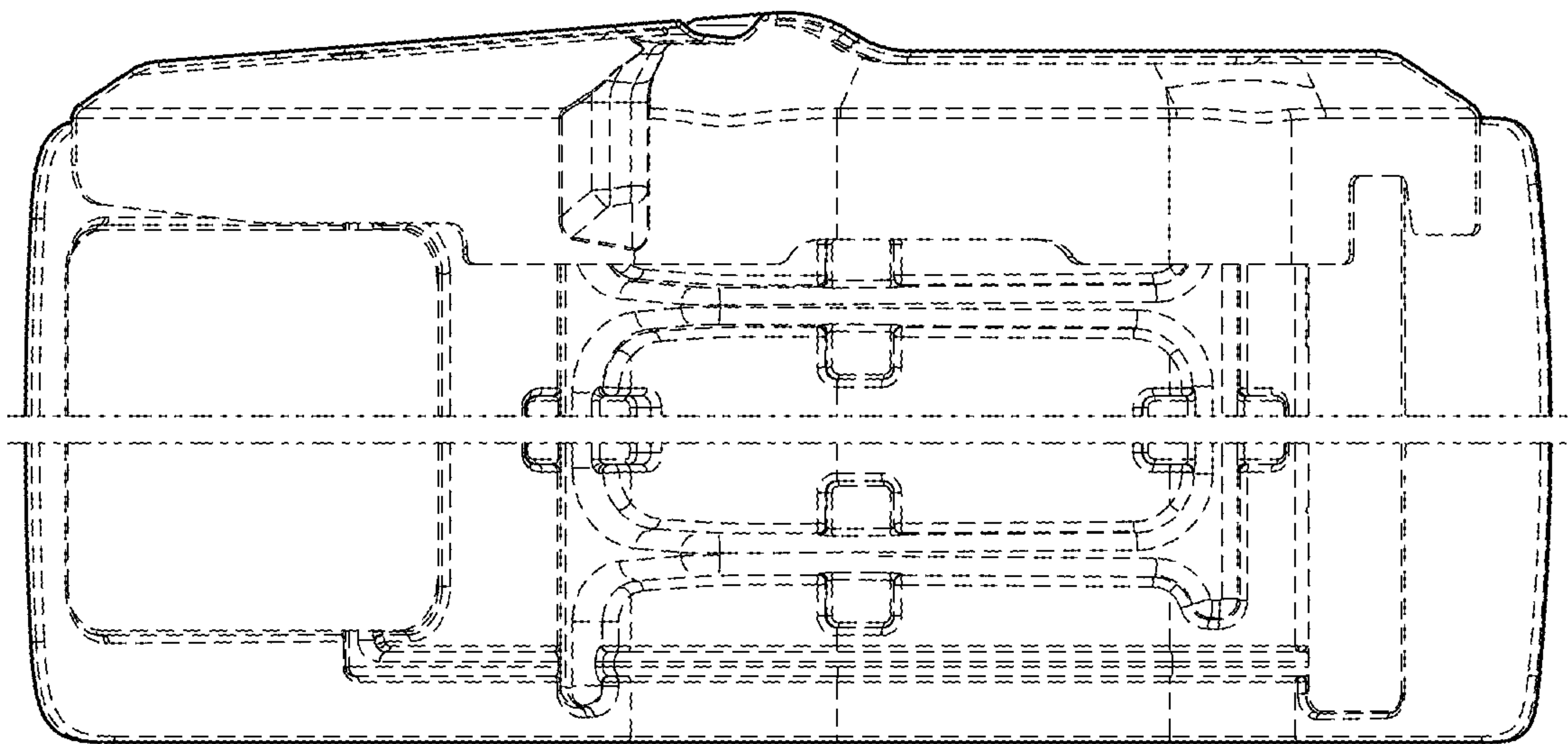

FIG. 15

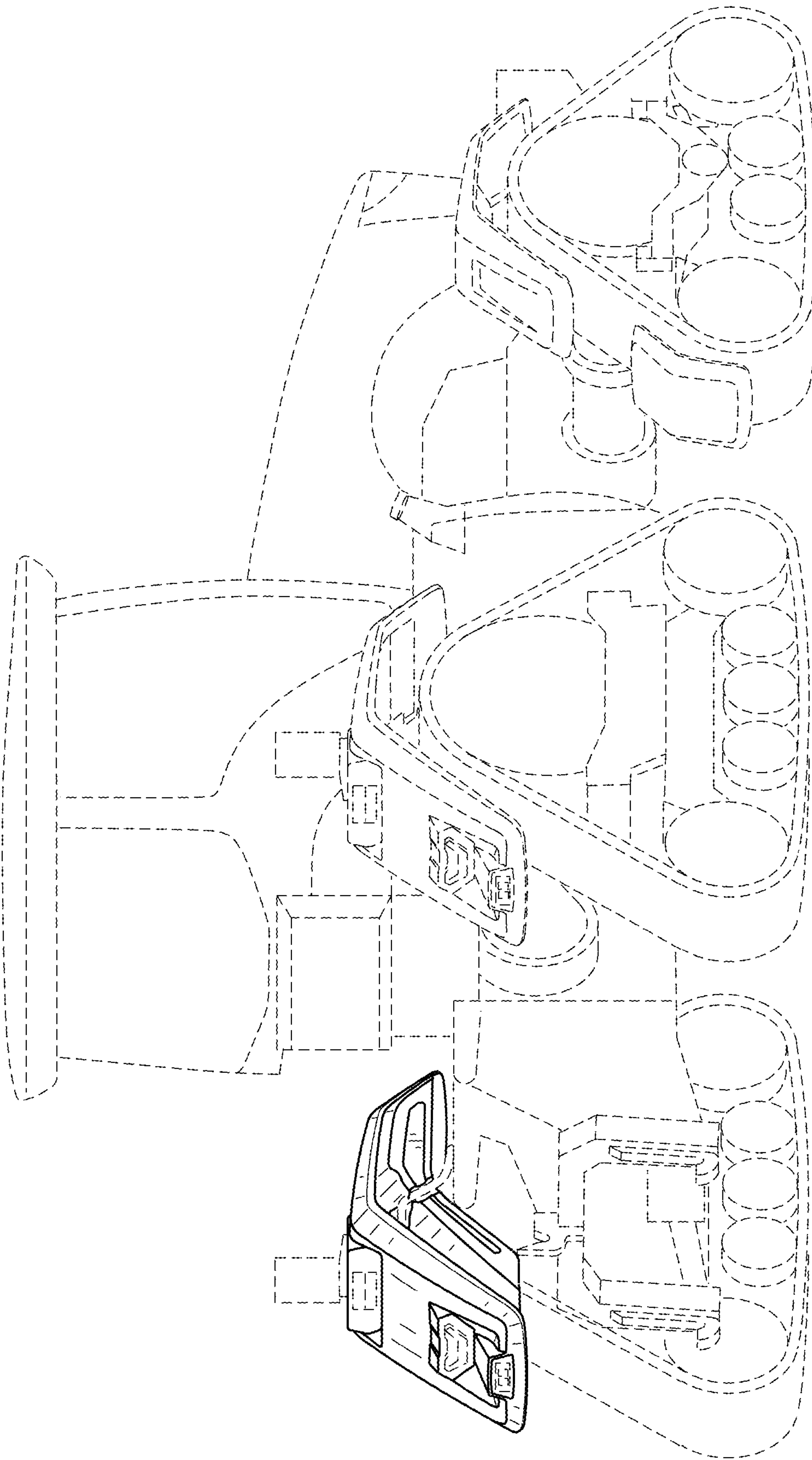

FIG. 16

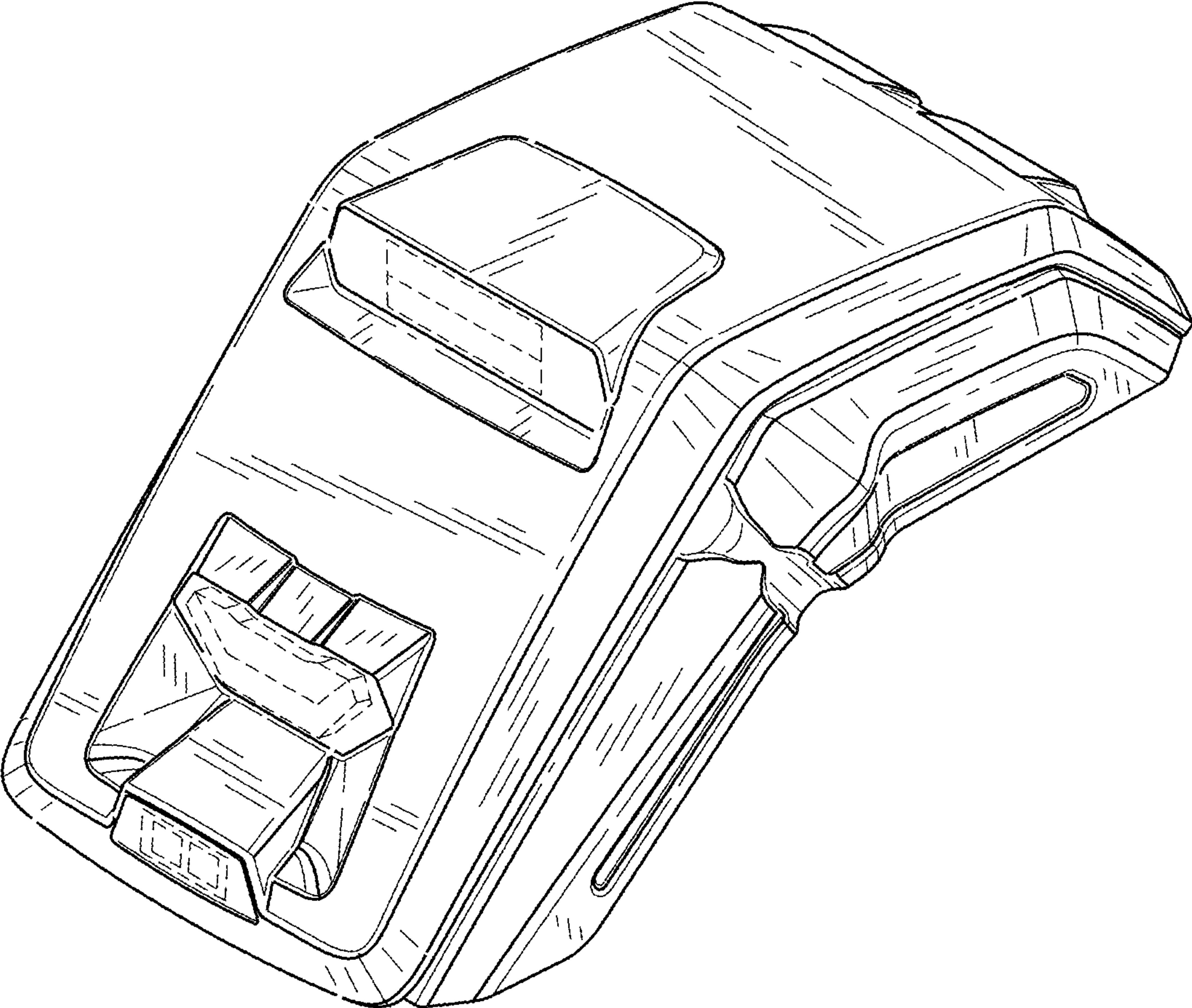

FIG. 17

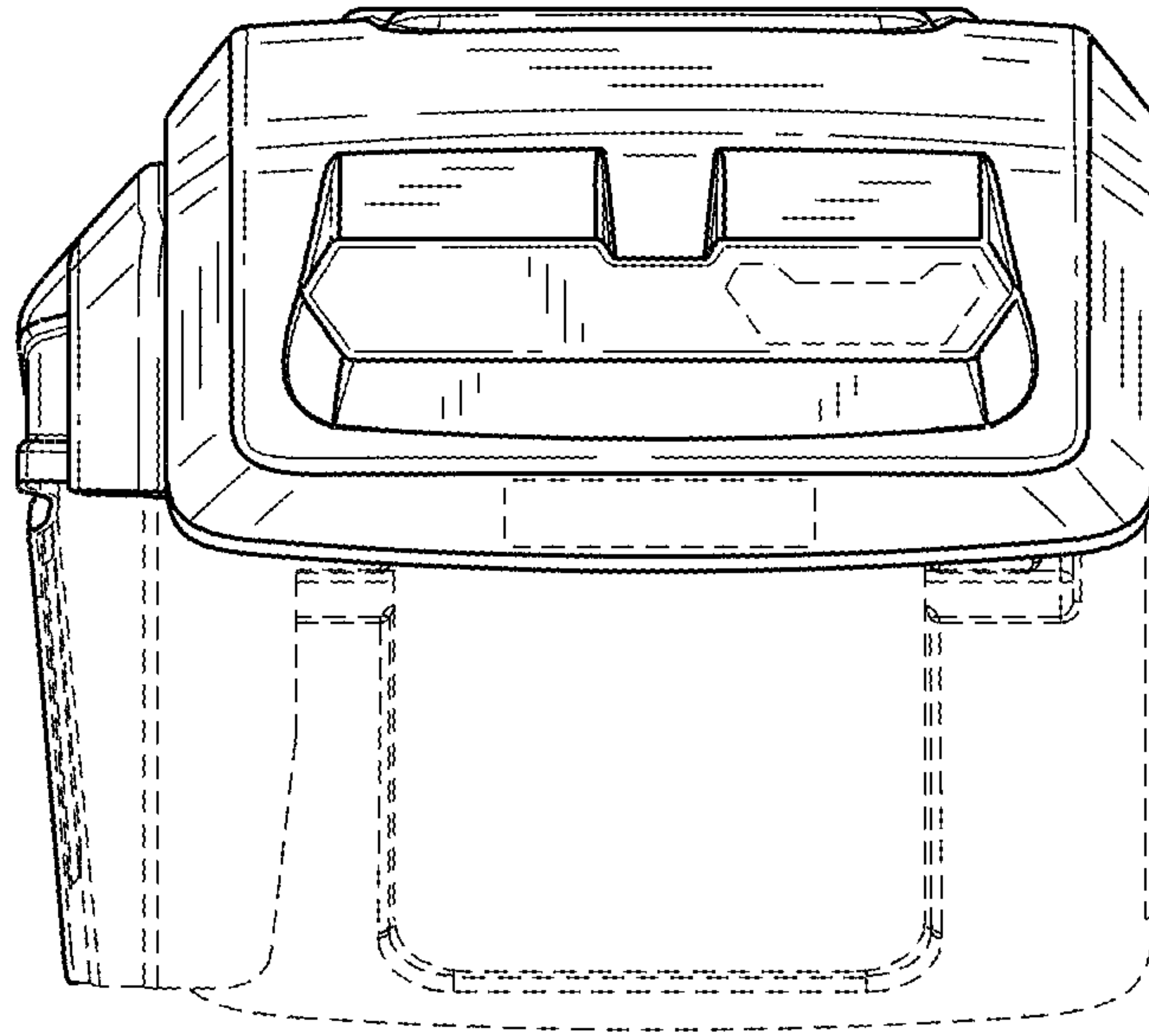

FIG. 18

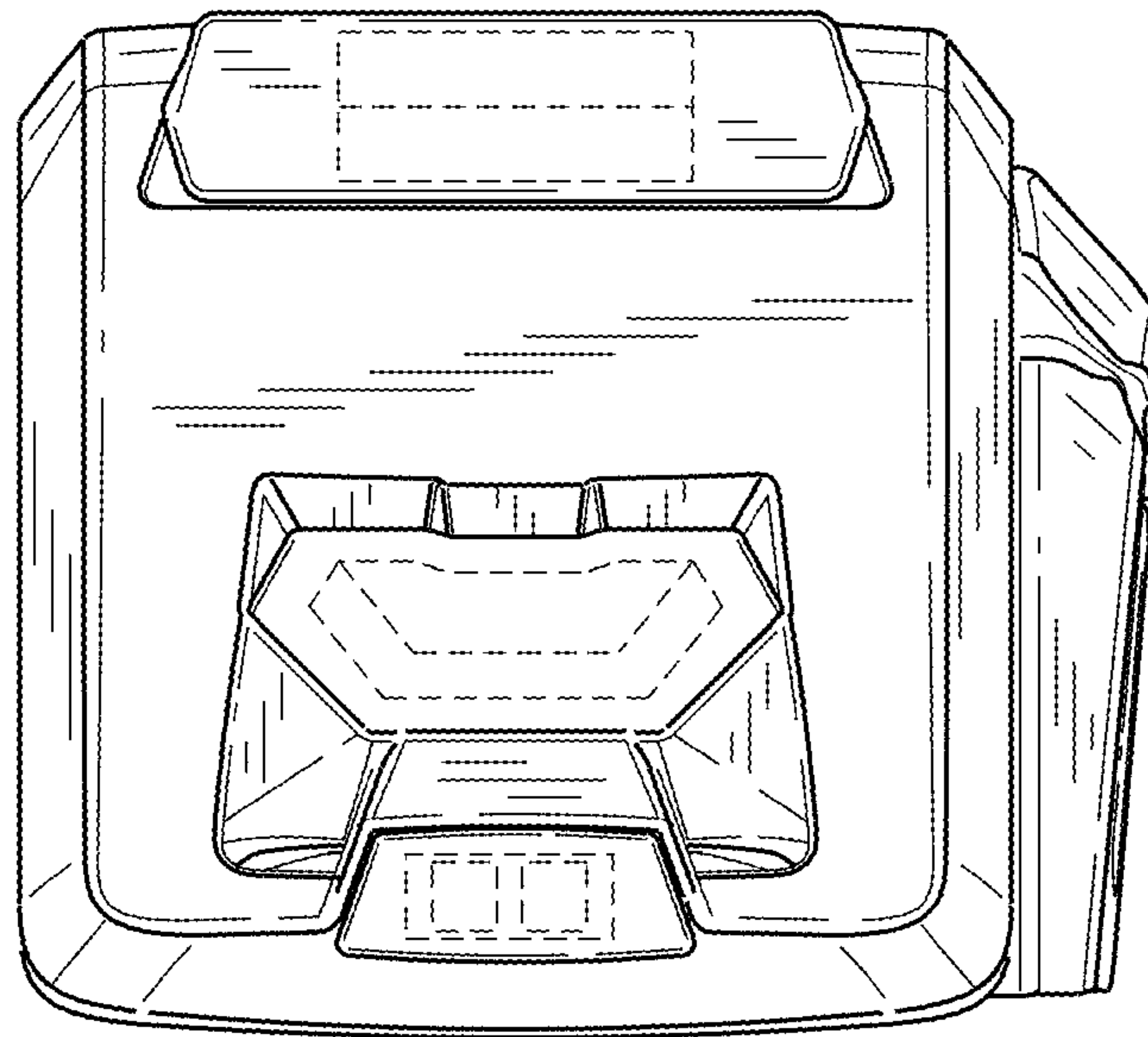

FIG. 19

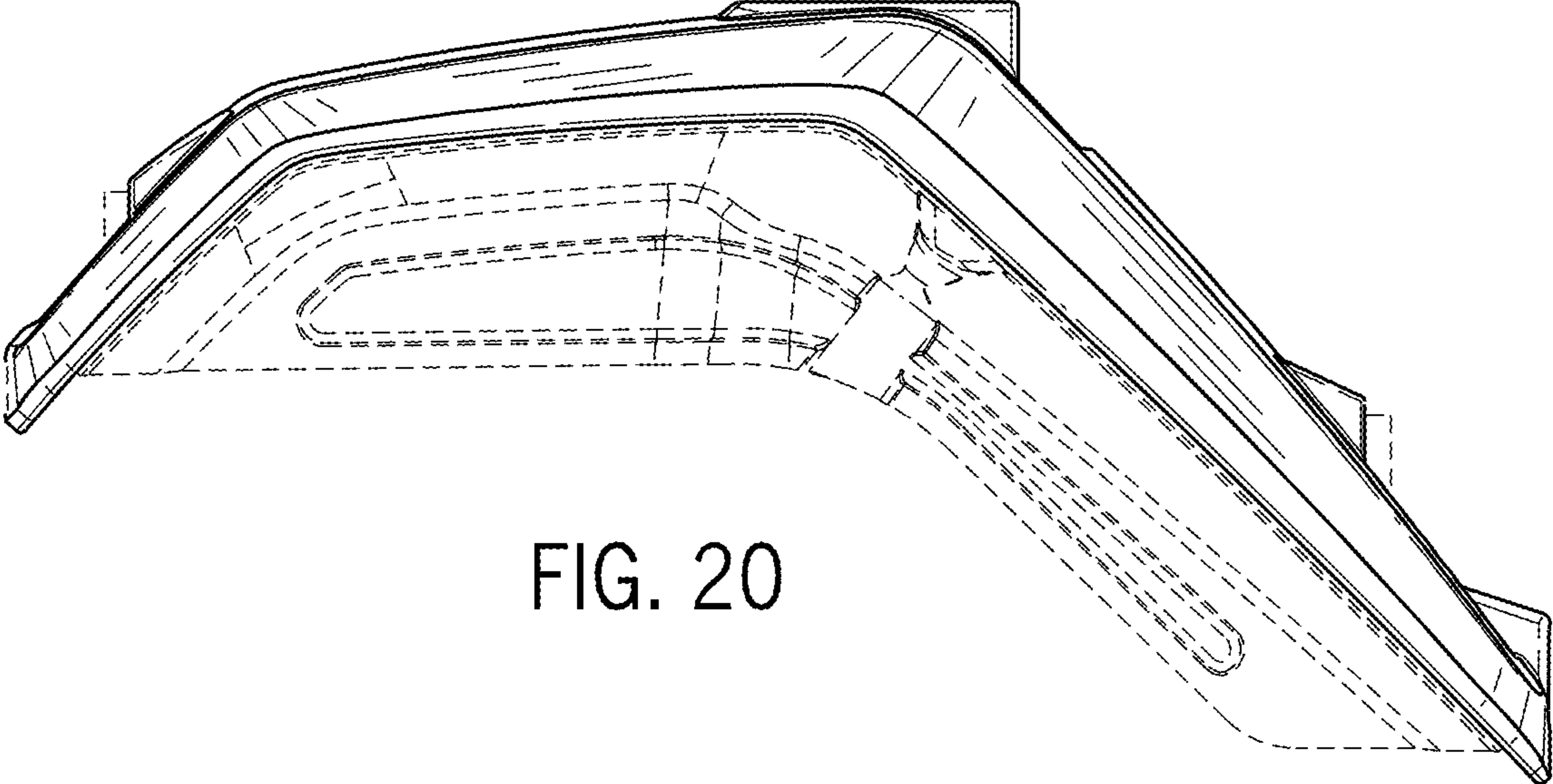

FIG. 20

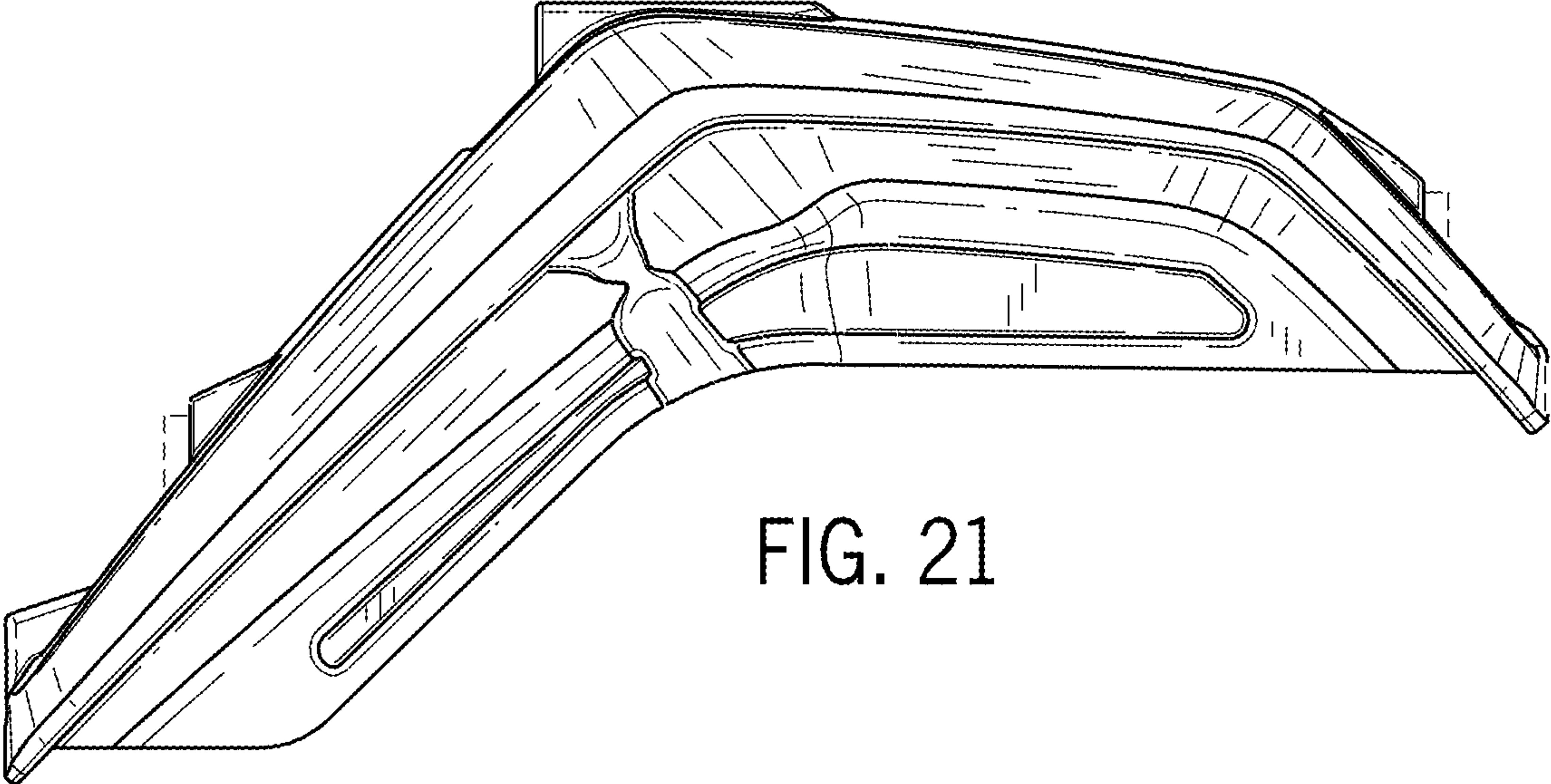

FIG. 21

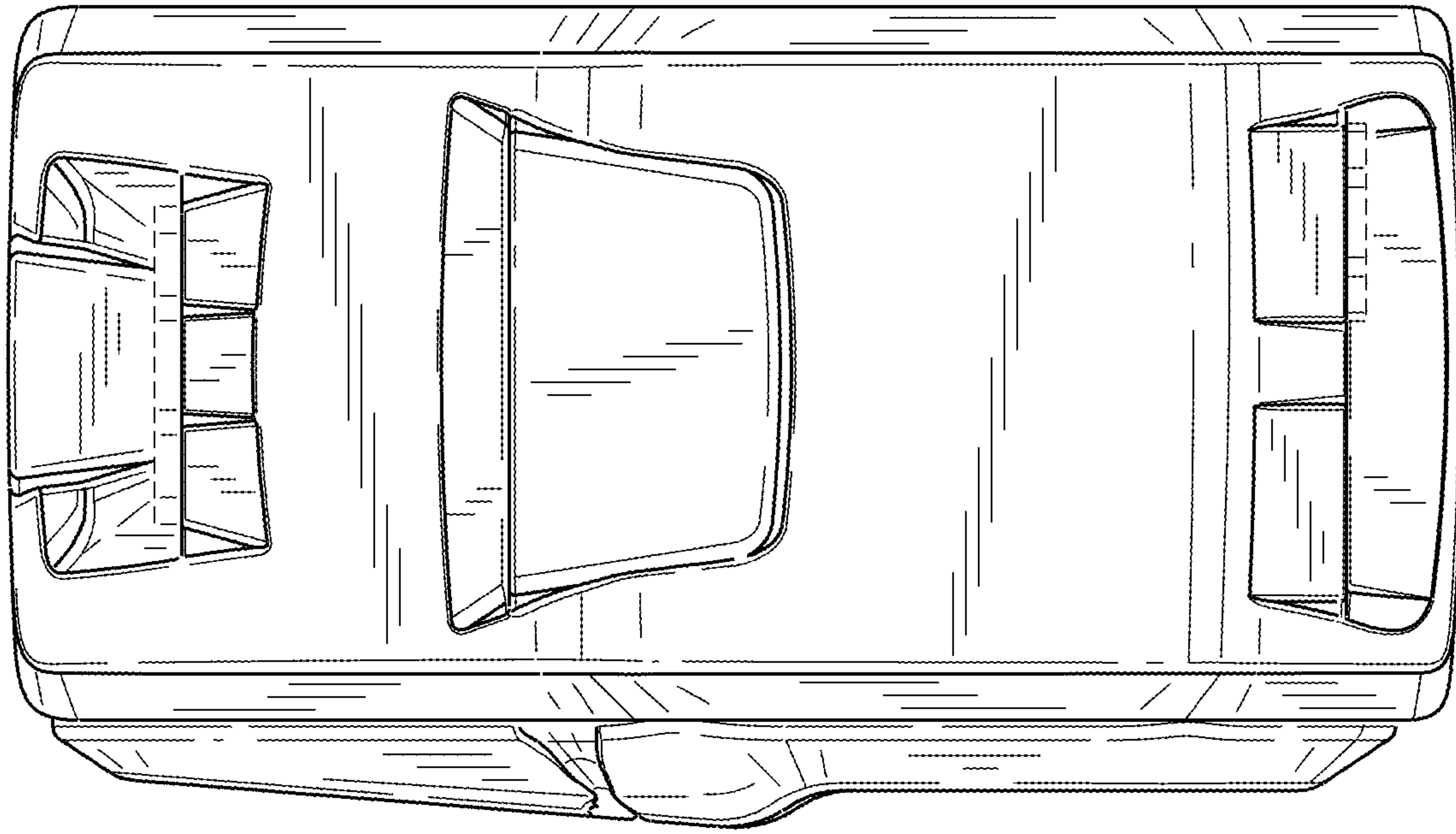

FIG. 22

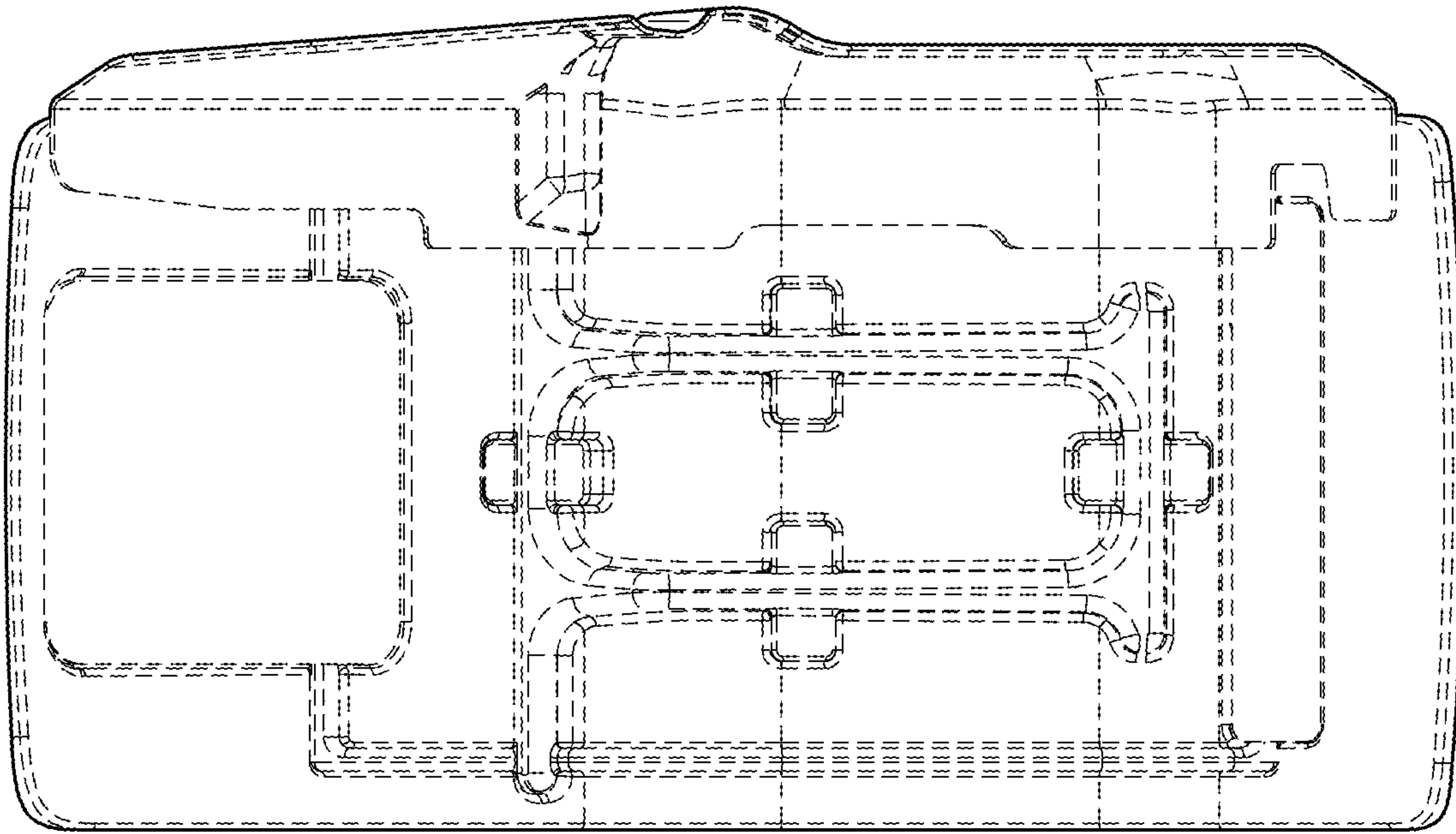

FIG. 23

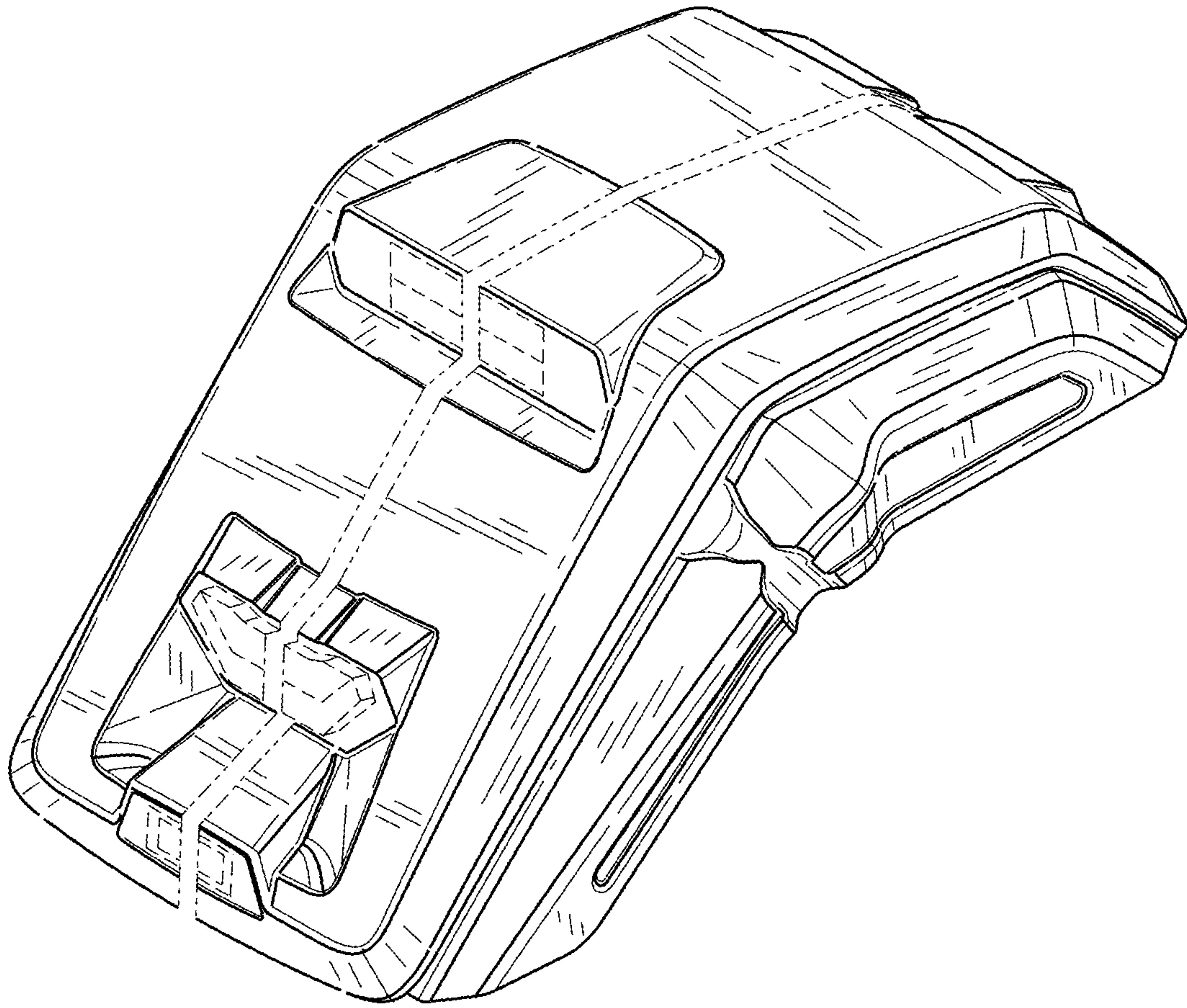

FIG. 24

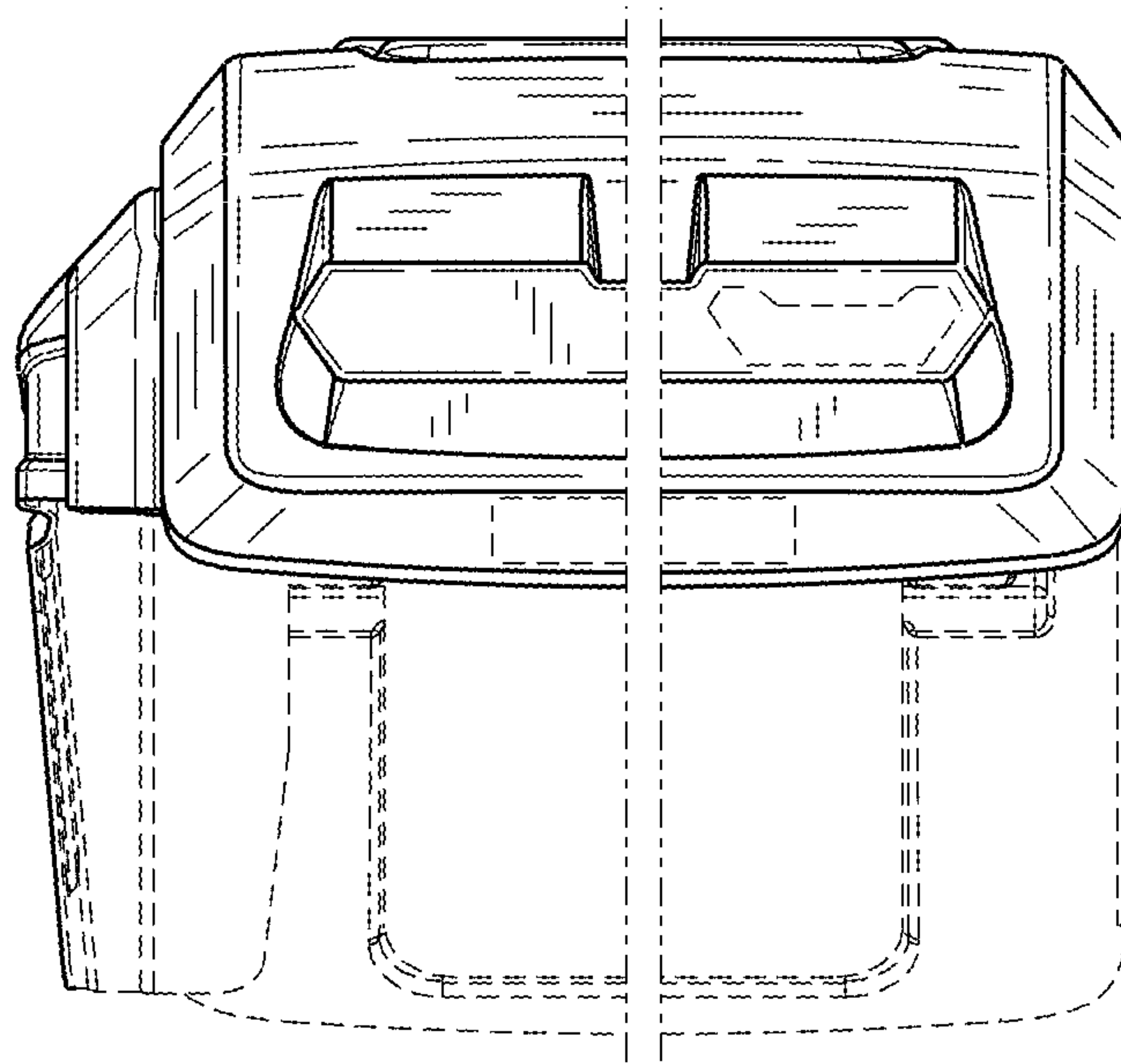

FIG. 25

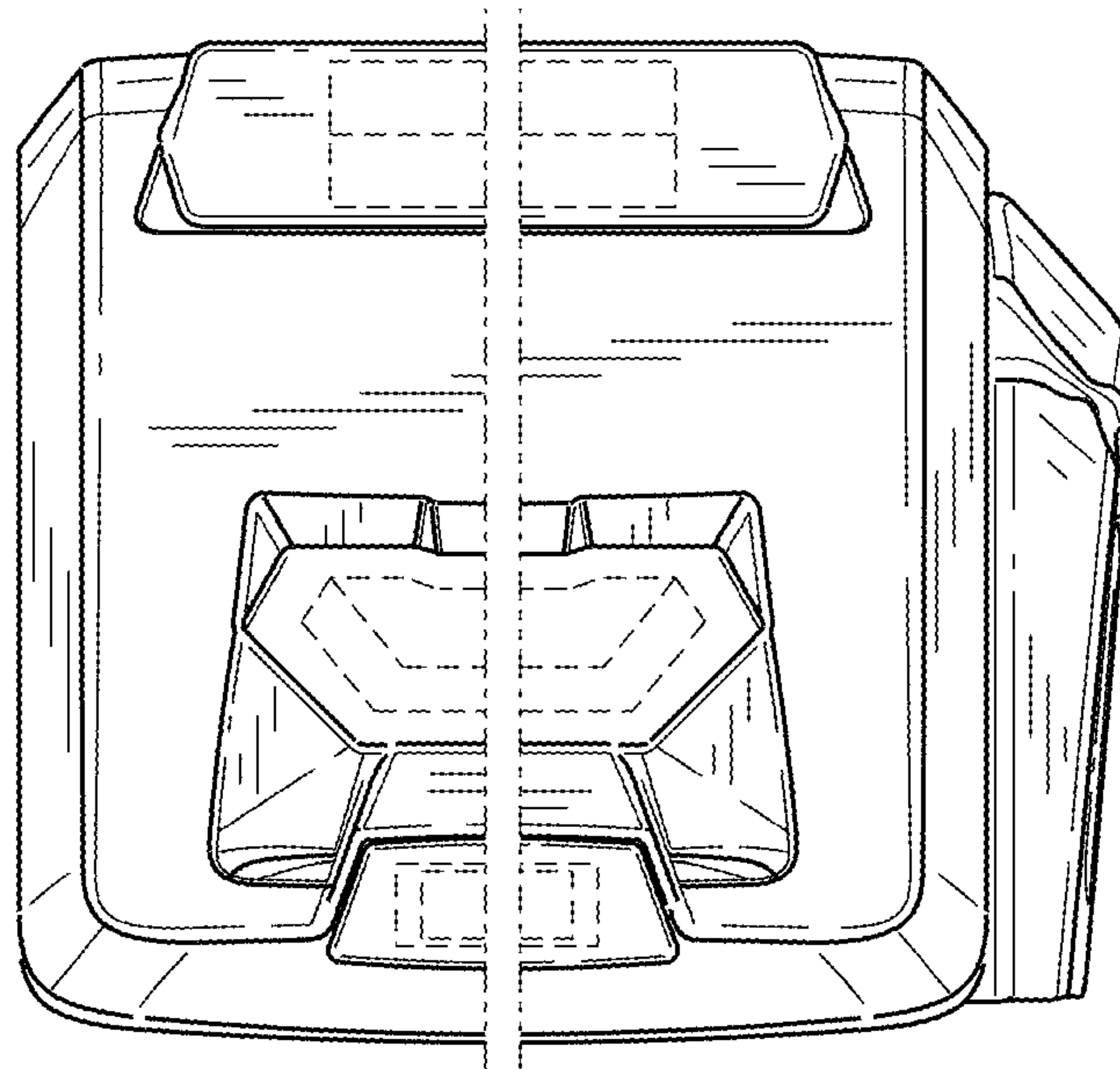

FIG. 26

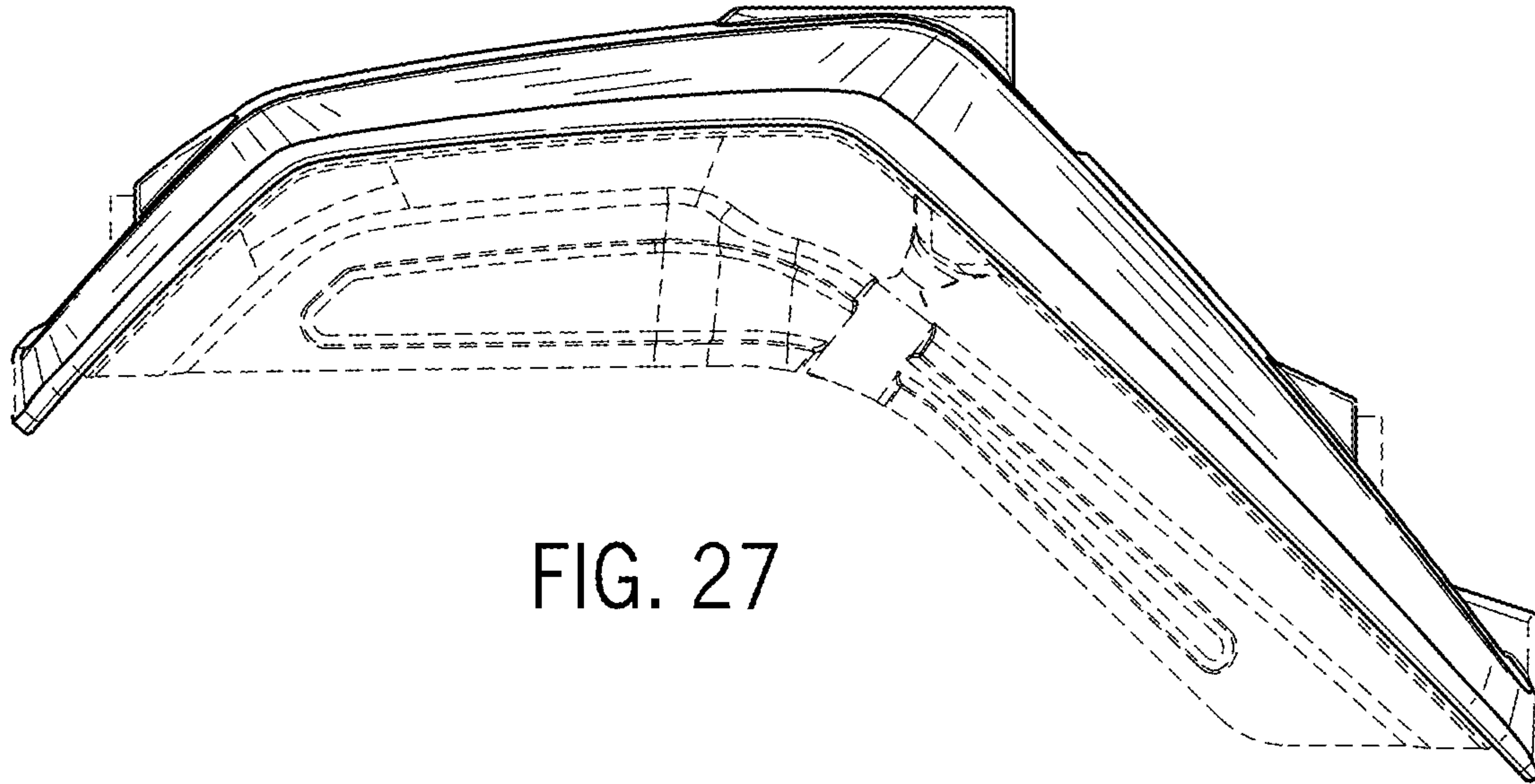

FIG. 27

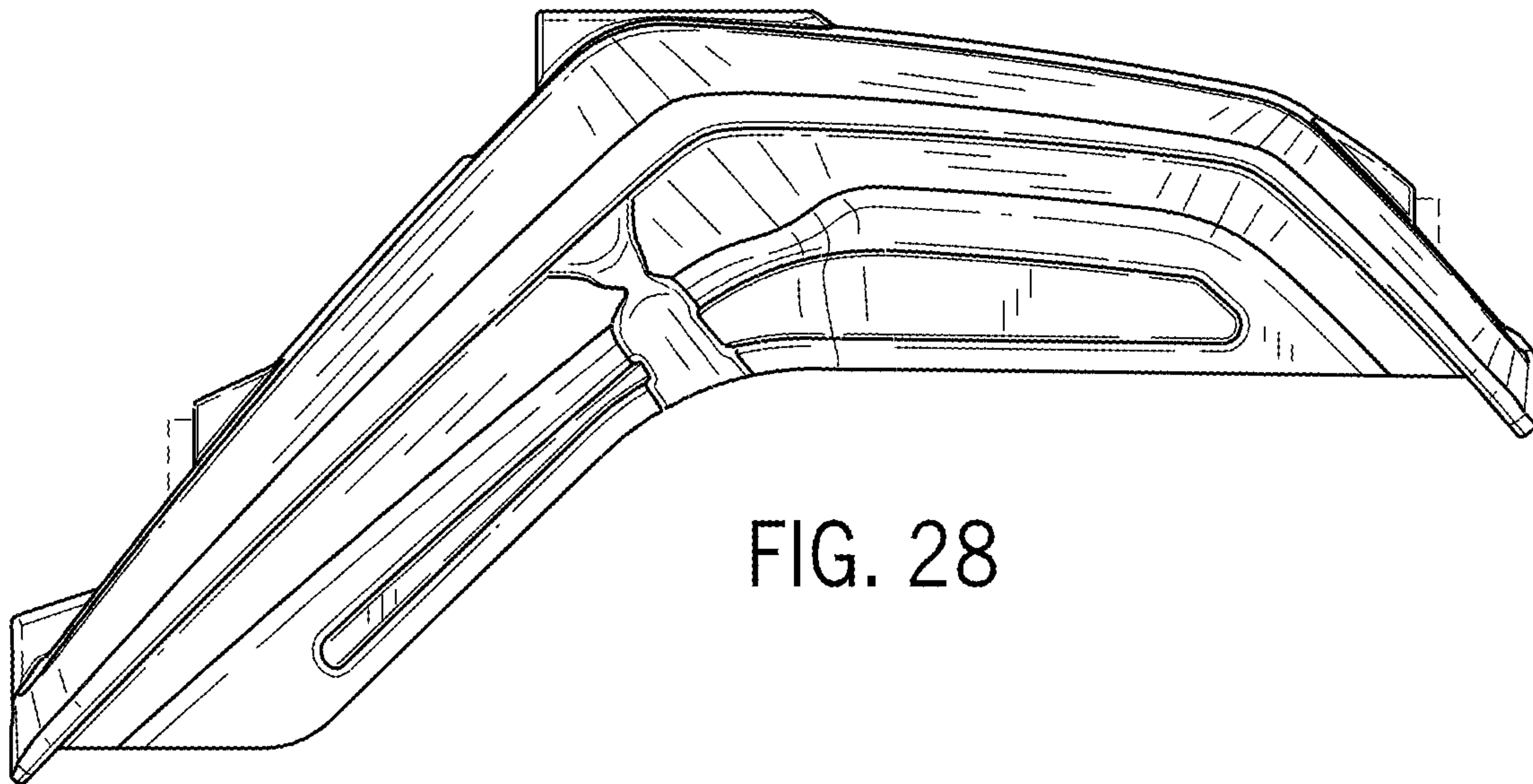

FIG. 28

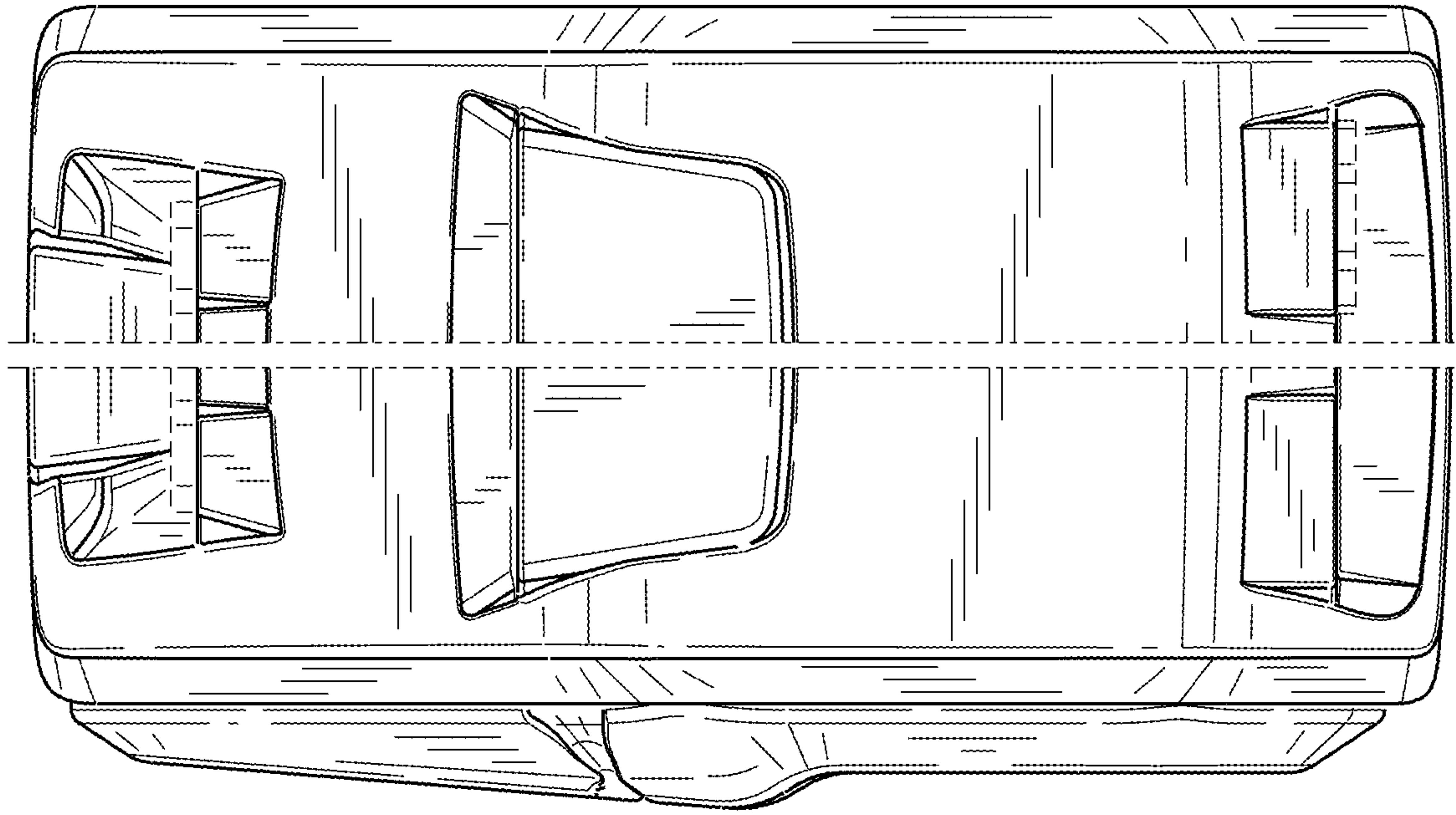

FIG. 29

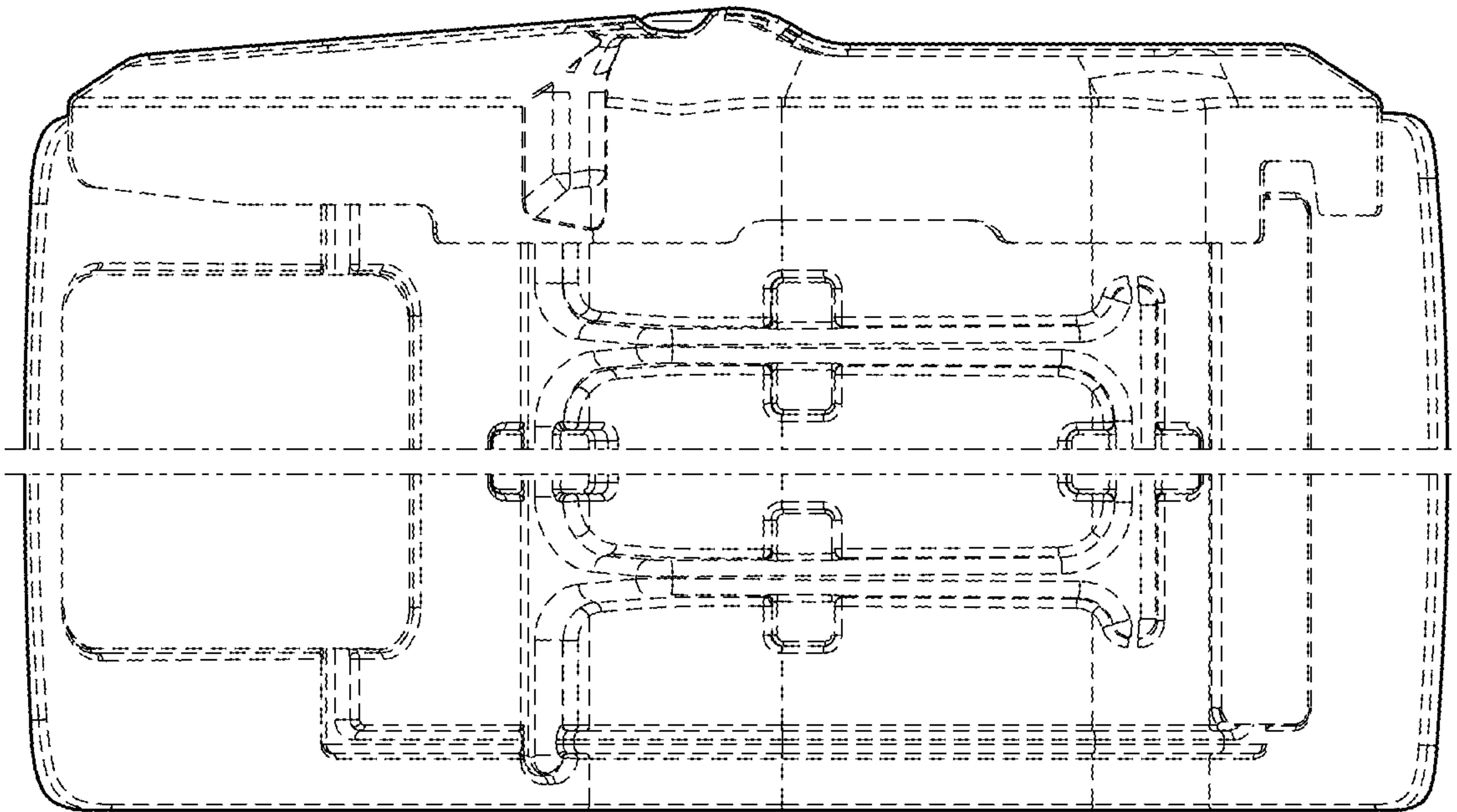

FIG. 30

UNITED STATES PATENT AND TRADEMARK OFFICE
CERTIFICATE OF CORRECTION

PATENT NO. : D891,336 S
APPLICATION NO. : 29/680650
DATED : July 28, 2020
INVENTOR(S) : Christopher A. Bering et al.

Page 1 of 1

It is certified that error appears in the above-identified patent and that said Letters Patent is hereby corrected as shown below:

On the Title Page

Column 2, in the Item (57), under "DESCRIPTION", Line 19, delete "according to according to" and insert -- according to --, therefor.

Column 2, in the Item (57), under "DESCRIPTION", Line 34, delete "and," and insert -- and --, therefor.

Signed and Sealed this
Twenty-second Day of December, 2020

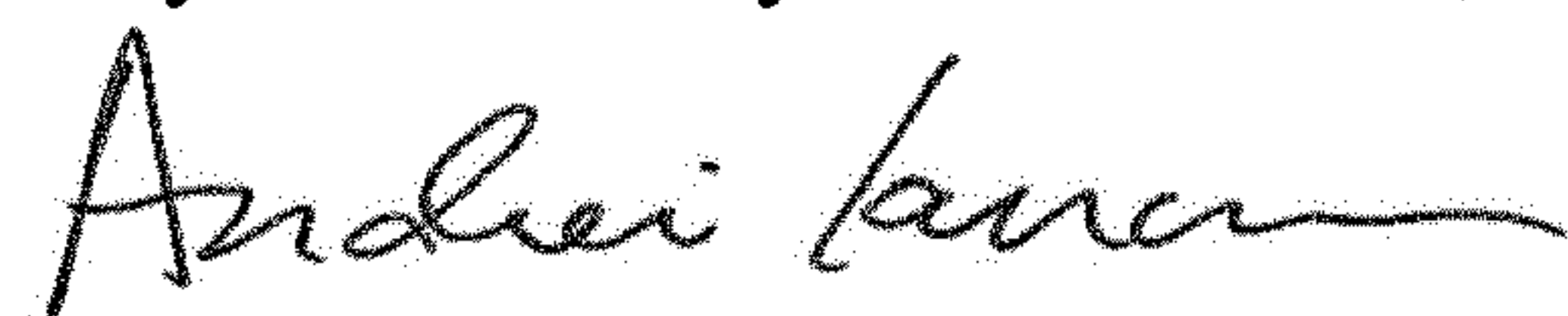

Andrei Iancu
Director of the United States Patent and Trademark Office