



US00D891299S

(12) **United States Design Patent** (10) **Patent No.:** **US D891,299 S**  
**Shkinder et al.** (45) **Date of Patent:** **\*\* Jul. 28, 2020**

(54) **CAR**  
(71) Applicant: **McLaren Automotive Limited**,  
Woking, Surrey (GB)  
(72) Inventors: **Maksym Shkinder**, Surrey (GB);  
**Robert Melville**, Surrey (GB)  
(73) Assignee: **McLaren Automotive Limited**,  
Woking, Surrey (GB)

D774,947 S \* 12/2016 Anscheidt ..... D12/88  
D780,063 S \* 2/2017 Stephenson ..... D12/88  
D781,747 S 3/2017 Stephenson  
D790,398 S \* 6/2017 Perini ..... D12/88  
D790,402 S \* 6/2017 Perini ..... D12/88  
D801,227 S 10/2017 Stephenson  
D804,355 S 12/2017 Stephenson  
D823,724 S 7/2018 Melville et al.

(Continued)

**FOREIGN PATENT DOCUMENTS**

EM 002105403-0001 9/2012  
EM 002105403-0002 9/2012

(\*\*) Term: **15 Years**

(21) Appl. No.: **29/664,496**

(22) Filed: **Sep. 25, 2018**

(30) **Foreign Application Priority Data**

Mar. 26, 2018 (GB) ..... 6031651

(51) **LOC (12) Cl.** ..... **12-08**

(52) **U.S. Cl.**  
USPC ..... **D12/88**

(58) **Field of Classification Search**  
USPC ..... D12/86, 90-92, 88; D21/424, 433, 434,  
D21/533; 296/181.1-181.5, 183.1  
CPC ..... B62D 25/00; B62D 25/06; B62D 33/00;  
B62D 35/00

See application file for complete search history.

(56) **References Cited**

**U.S. PATENT DOCUMENTS**

D361,046 S 8/1995 Watkins et al.  
D628,124 S 11/2010 Stephenson  
D715,690 S \* 10/2014 Perini ..... D12/88  
D717,211 S 11/2014 Stephenson  
D734,212 S 7/2015 Stephenson  
D734,213 S 7/2015 Stephenson  
D767,446 S 9/2016 Stephenson  
D772,106 S \* 11/2016 Hitzinger ..... D12/88  
D774,416 S \* 12/2016 Perini ..... D12/88

**OTHER PUBLICATIONS**

[No Author Listed] McLaren 540C Coupe. Publicly available May 28, 2015. 3 pages.

(Continued)

*Primary Examiner* — Melody N Brown

(74) *Attorney, Agent, or Firm* — Wolf, Greenfield & Sacks, P.C.

(57) **CLAIM**

The ornamental design for a car, as shown and described.

**DESCRIPTION**

FIG. 1 is a top, front, right side perspective view of a car showing our new design;  
FIG. 2 is a top, rear, left side perspective view thereof;  
FIG. 3 is a right side elevation view thereof;  
FIG. 4 is a left side elevation view thereof;  
FIG. 5 is a front elevation view thereof;  
FIG. 6 is a rear elevation view thereof; and,  
FIG. 7 is a top plan view thereof.  
The broken lines shown throughout the drawing views are for environmental and illustrative purposes that form no part of the claimed design.

**1 Claim, 6 Drawing Sheets**

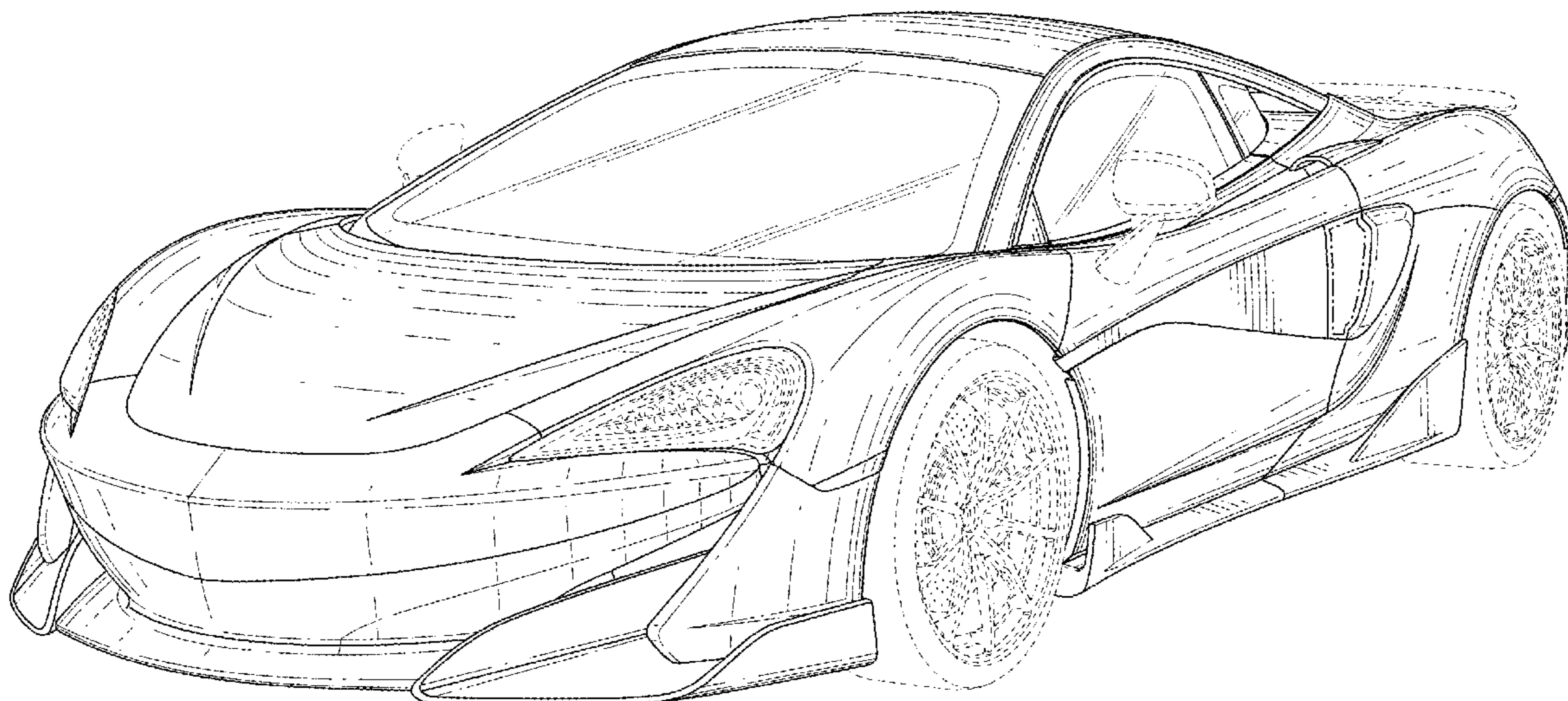

(56)

**References Cited**

U.S. PATENT DOCUMENTS

D844,488 S \* 4/2019 Melville ..... D12/88  
D845,170 S \* 4/2019 Melville ..... D12/88

OTHER PUBLICATIONS

[No Author Listed] McLaren 570 Gt. Publicly available May 16, 2016. 2 pages.

[No Author Listed] McLaren 570S Coupe. Publicly available Mar. 31, 2015. 3 pages.

[No Author Listed] McLaren 570S GT4. Publicly available Mar. 15, 2016. 3 pages.

[No Author Listed] McLaren 570S Spider. Publicly available Jun. 14, 2017. 3 pages.

[No Author Listed] McLaren 570S Sprint 22. Publicly available Jun. 22, 2016. 2 pages.

\* cited by examiner

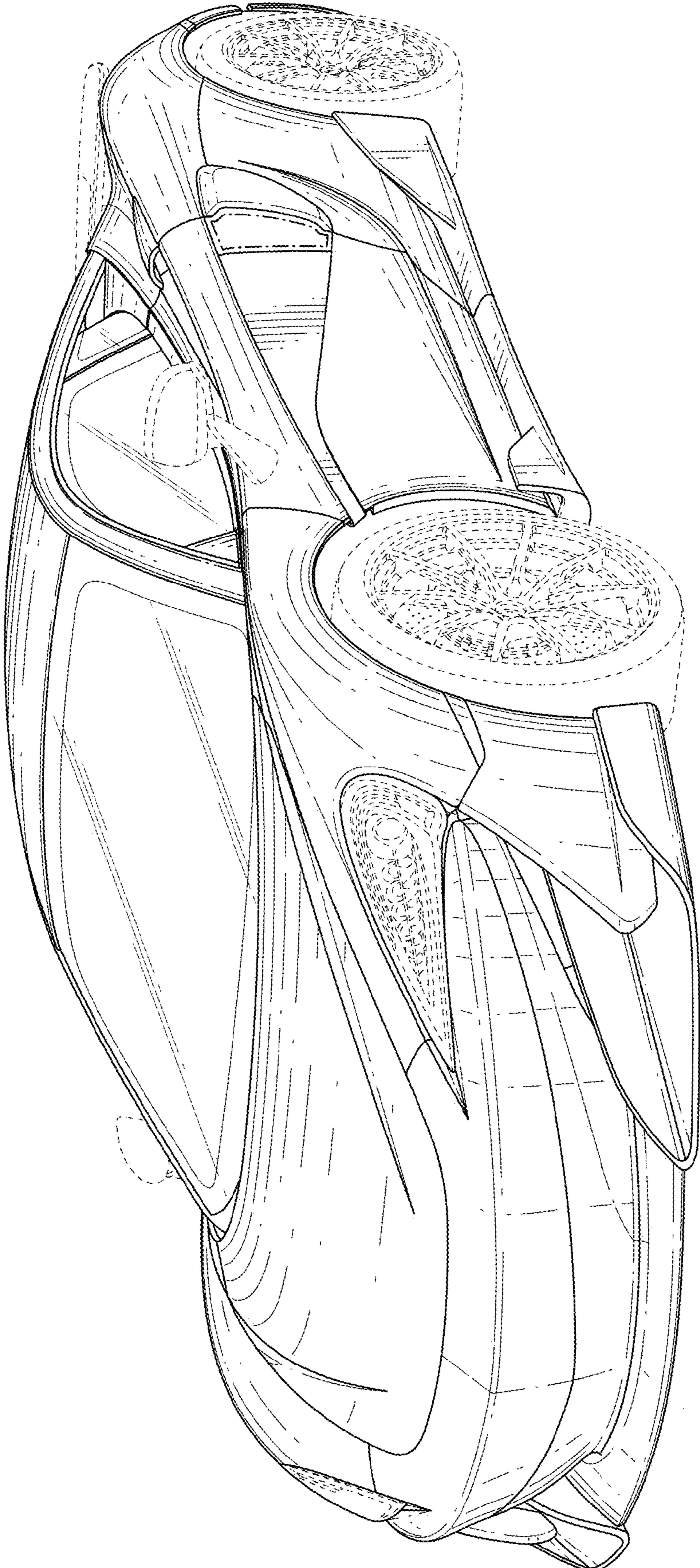

FIG. 1

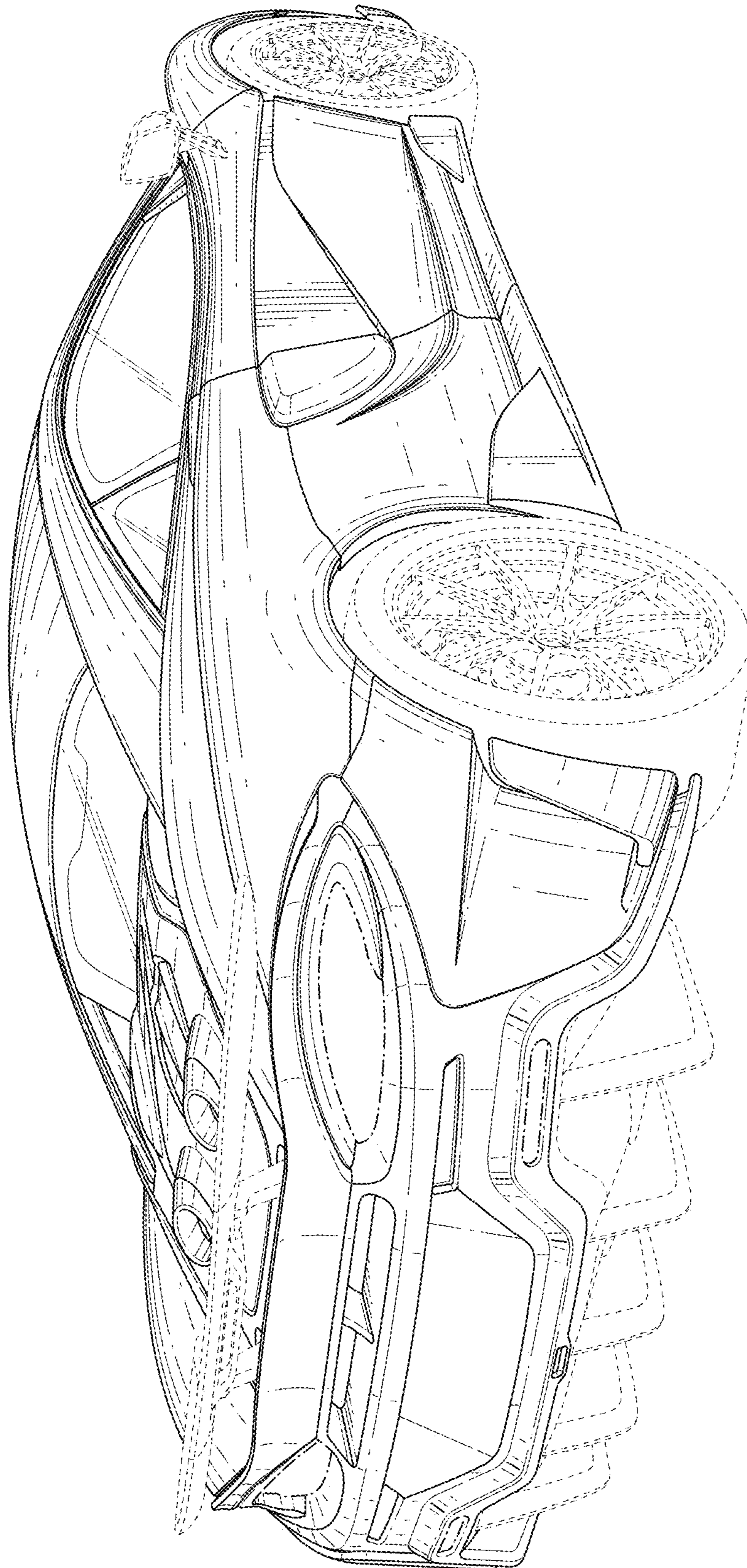

FIG. 2

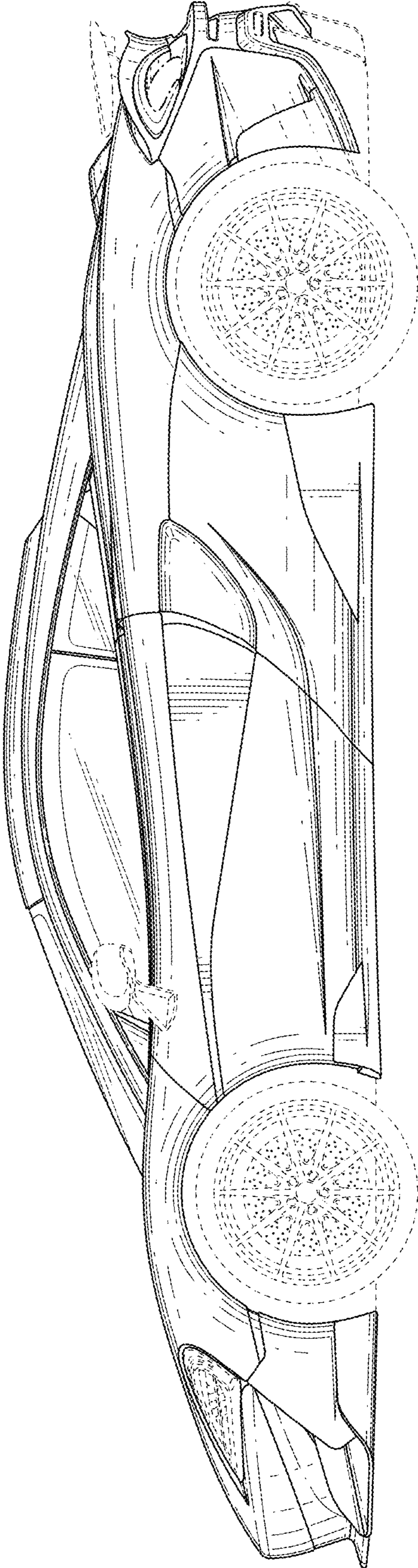

FIG. 3

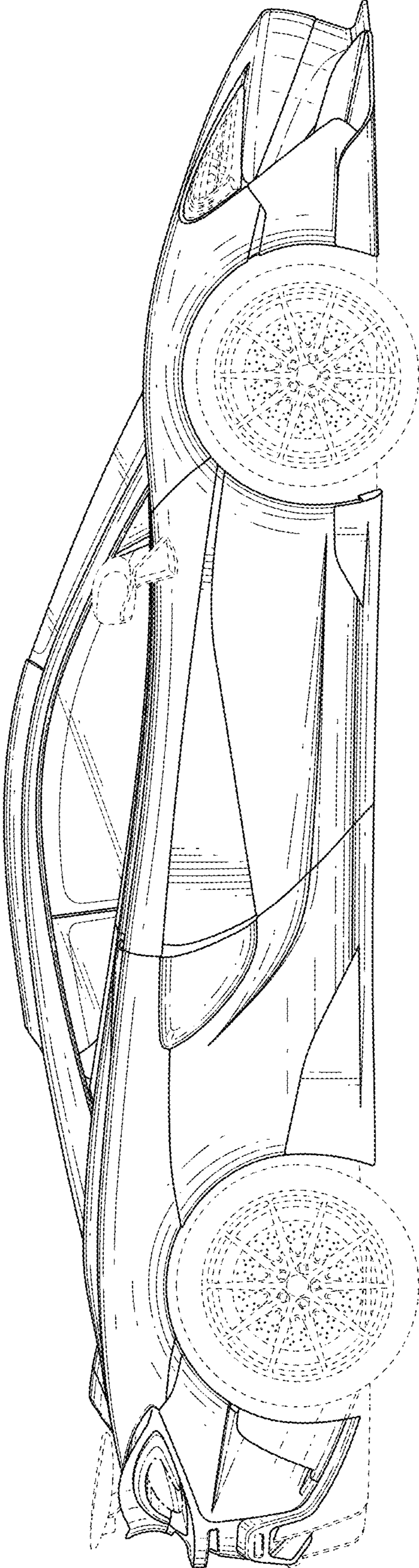
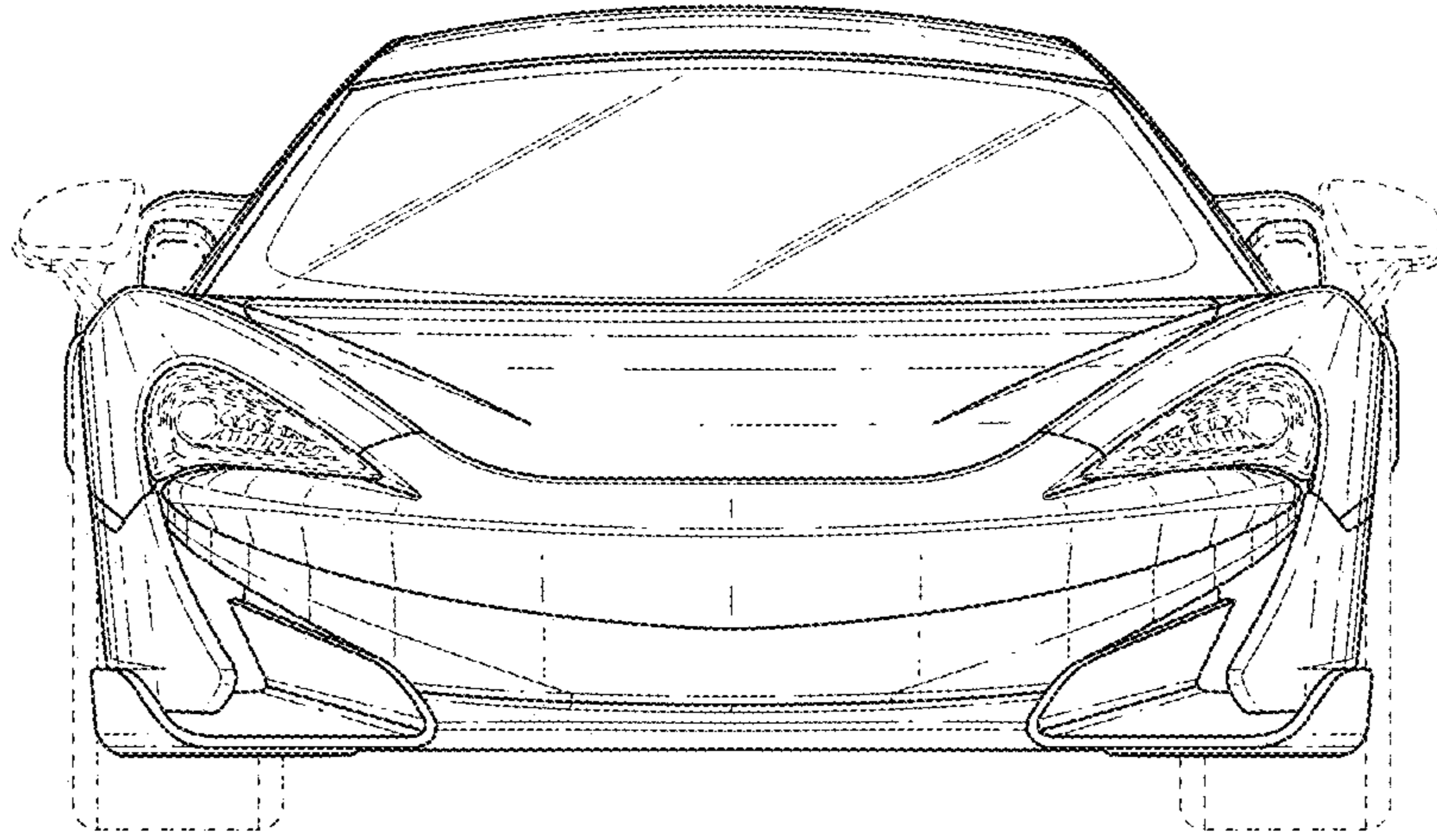
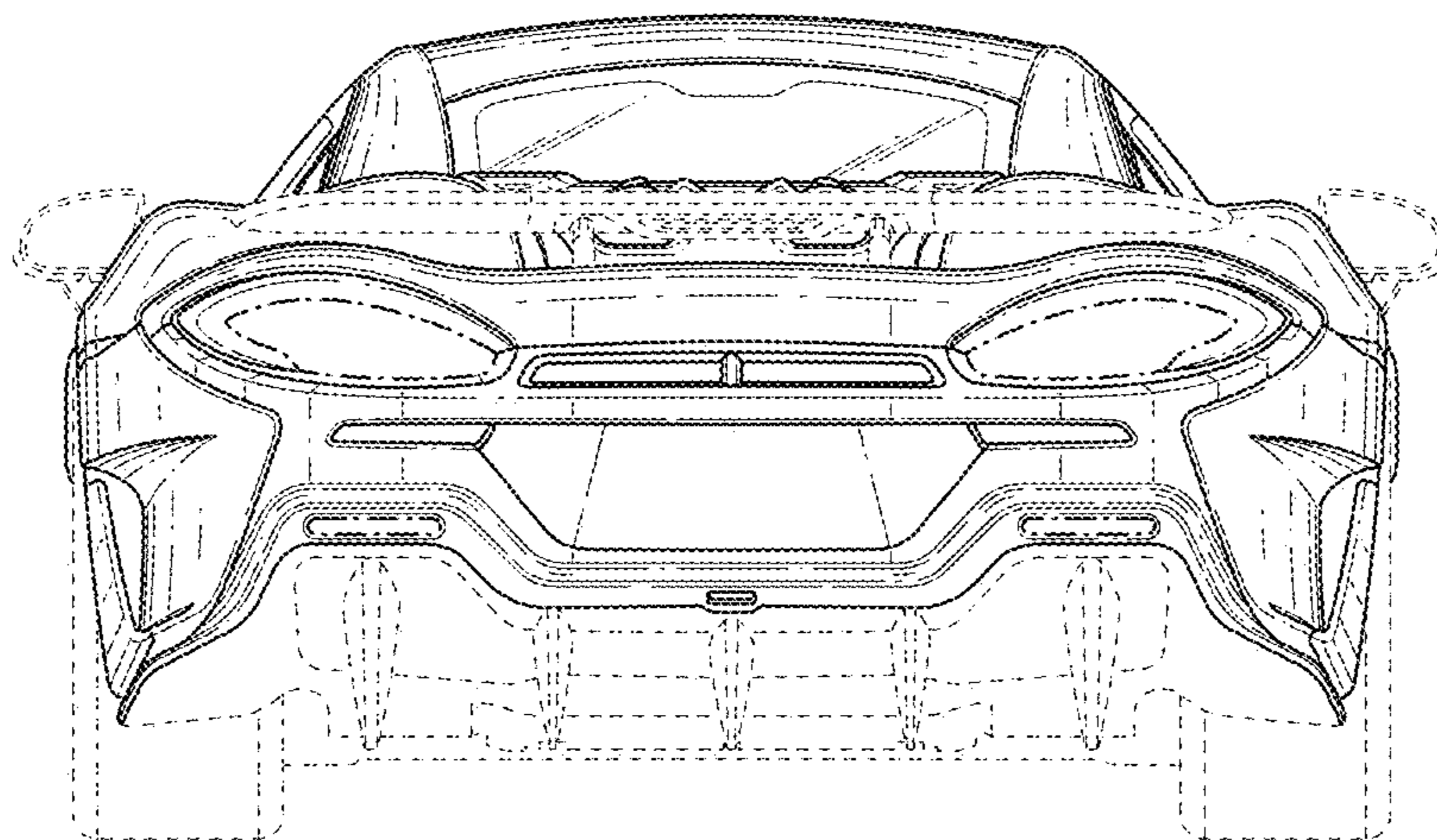

FIG. 4



*FIG. 5*



*FIG. 6*

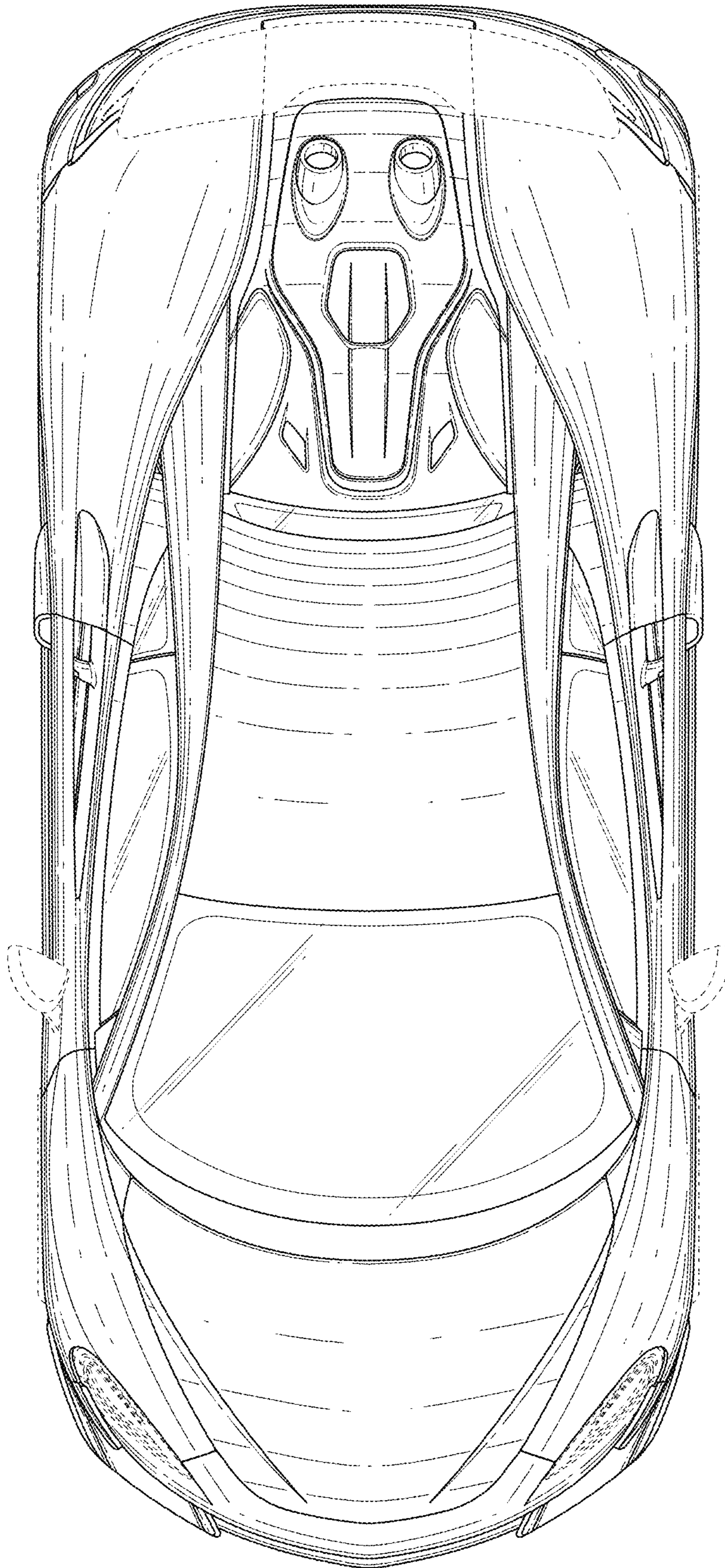

FIG. 7