



US00D890872S

(12) **United States Design Patent**
Furstenburg

(10) **Patent No.:** **US D890,872 S**

(45) **Date of Patent:** **** Jul. 21, 2020**

(54) **PUTTER GRIP CORE**

(71) Applicant: **Matthew Ryan Furstenburg**, Crofton,
MD (US)

(72) Inventor: **Matthew Ryan Furstenburg**, Crofton,
MD (US)

(**) Term: **15 Years**

(21) Appl. No.: **29/676,837**

(22) Filed: **Jan. 15, 2019**

(51) **LOC (12) Cl.** **21-02**

(52) **U.S. Cl.**
USPC **D21/756**

(58) **Field of Classification Search**
USPC D21/756-759
CPC A63B 60/06-60/34; A63B 60/00; A63B
60/46; A63B 59/20; A63B 59/40; A63B
59/60-59/80; A63B 49/00-49/14; A63B
53/00-53/14

See application file for complete search history.

(56) **References Cited**

U.S. PATENT DOCUMENTS

D355,011 S *	1/1995	Subnick	D21/756
D399,901 S *	10/1998	Beyer	D21/756
5,993,327 A *	11/1999	Terril	A63B 53/007 473/297
D515,649 S *	2/2006	Zichmanis	D21/756
D516,653 S *	3/2006	Gazeley	D21/756
D531,243 S *	10/2006	Davis	D21/756
D602,106 S *	10/2009	Stellander	D21/756
D602,546 S *	10/2009	Lin	D21/756
D686,288 S *	7/2013	Threbank	D21/756
D717,894 S *	11/2014	Dingman	D21/756
D725,730 S *	3/2015	Ambrose	D21/756

D728,717 S *	5/2015	Cokewell	D21/756
D738,973 S *	9/2015	Dingman	D21/756
D756,473 S *	5/2016	McIlroy	D21/756
D768,251 S *	10/2016	Giannatti	D21/756
D772,361 S *	11/2016	Giannatti	D21/756
D774,611 S *	12/2016	Nunn	D21/756
9,700,772 B2 *	7/2017	Goldfader	A63B 53/14
D810,851 S *	2/2018	Giannatti	D21/756
D816,177 S *	4/2018	Garsen	D21/756
D845,415 S *	4/2019	Lapuz	D21/756
10,293,231 B2 *	5/2019	Breeden, III	A63B 53/14
D851,188 S *	6/2019	Cokewell	D21/756
D855,131 S *	7/2019	Chung	D21/756

* cited by examiner

Primary Examiner — Mitchell I. Siegel

(74) *Attorney, Agent, or Firm* — Dunlap, Bennett &
Ludwig PLLC; Brendan E. Squire

(57) **CLAIM**

The ornamental design for a putter grip core, as shown and described.

DESCRIPTION

FIG. 1 is a perspective view of the putter grip core showing my new design;
FIG. 2 is a front elevation view thereof;
FIG. 3 is a rear elevation view thereof;
FIG. 4 is a top plan view thereof;
FIG. 5 is a bottom plan view thereof;
FIG. 6 is a right elevation view thereof;
FIG. 7 is a left elevation view thereof; and,
FIG. 8 is a reduced perspective view thereof, shown in use.
The broken lines shown on the drawings are included for the purpose of illustrating unclaimed subject matter and forms no part of the claimed design.

1 Claim, 3 Drawing Sheets

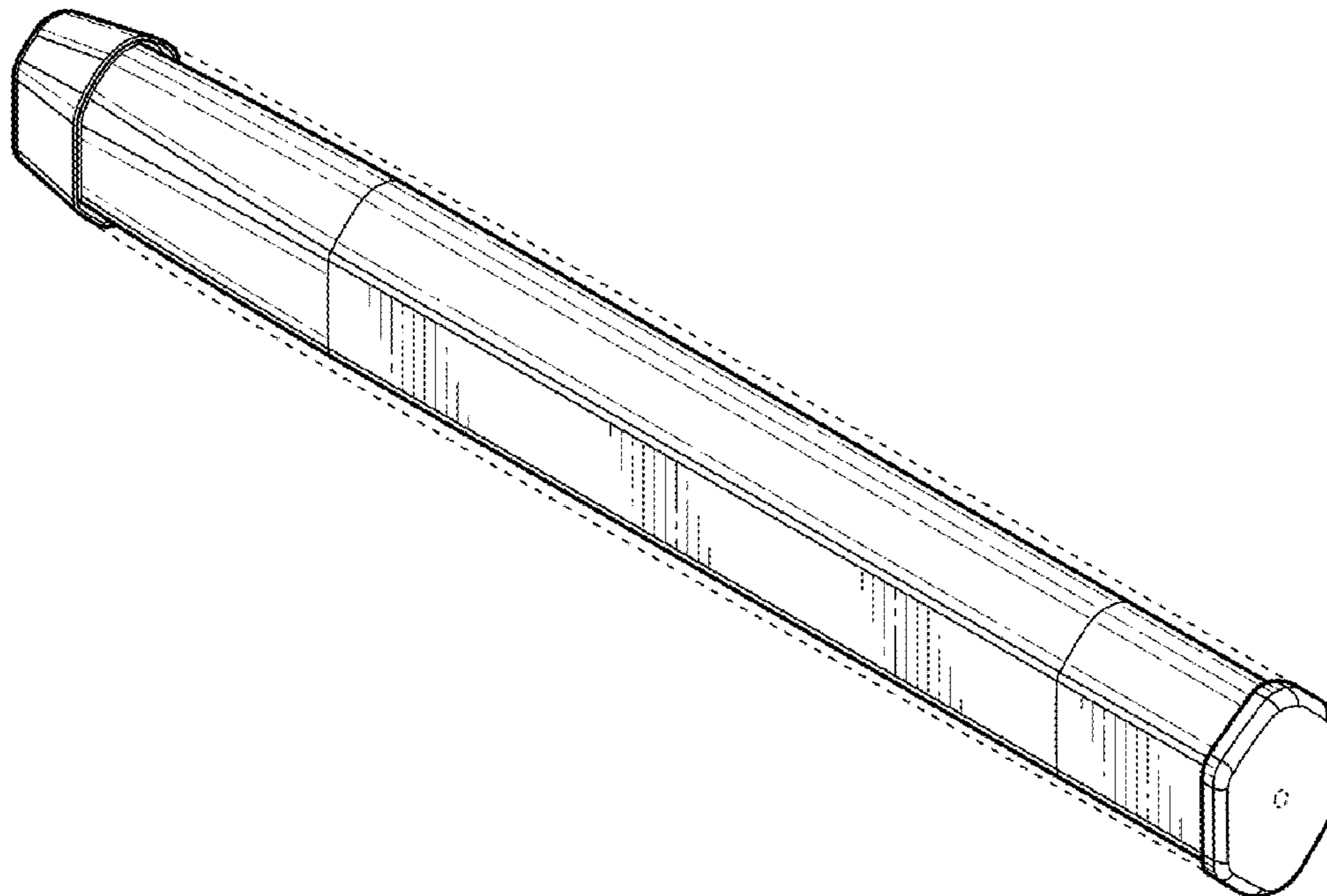

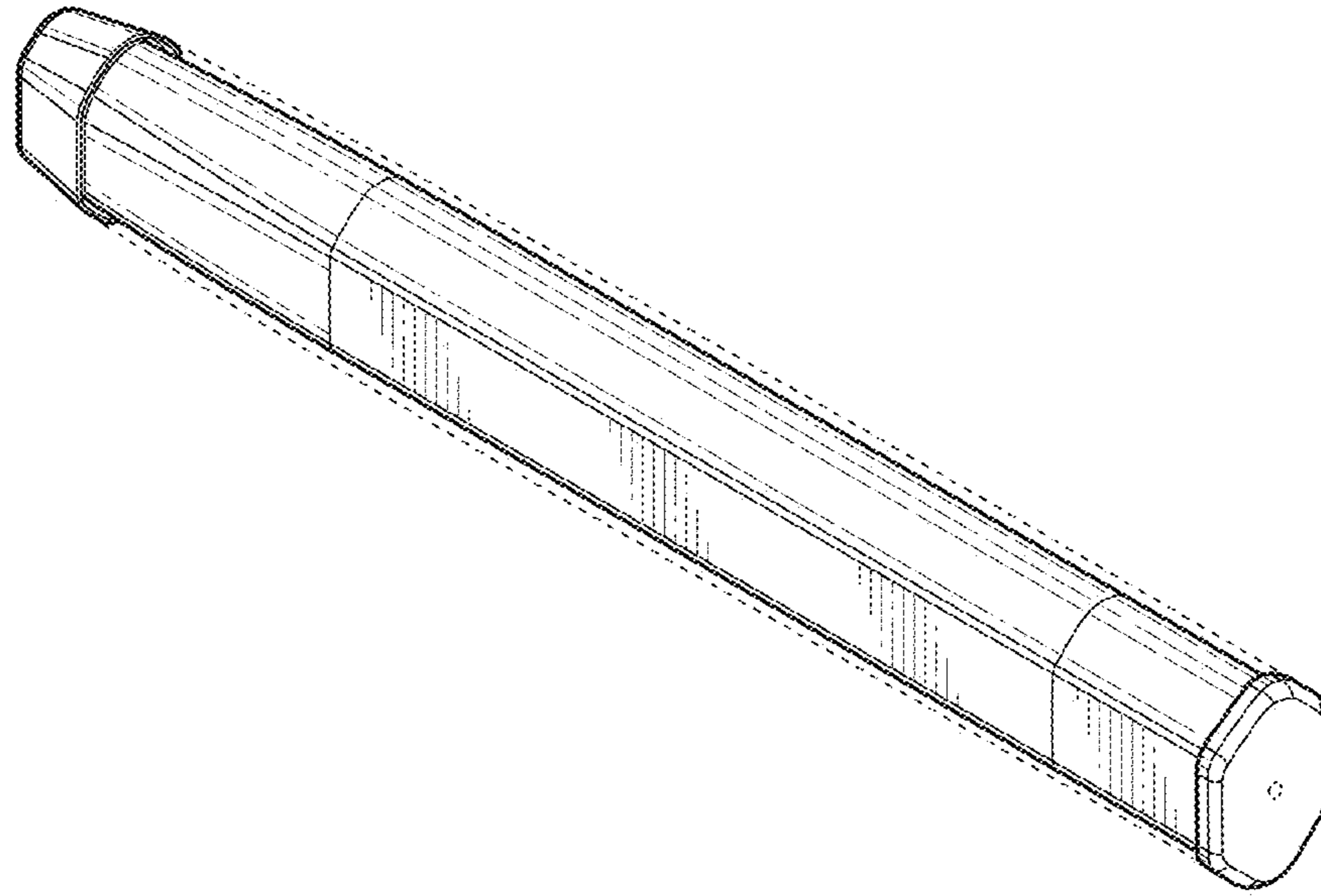

FIG. 1

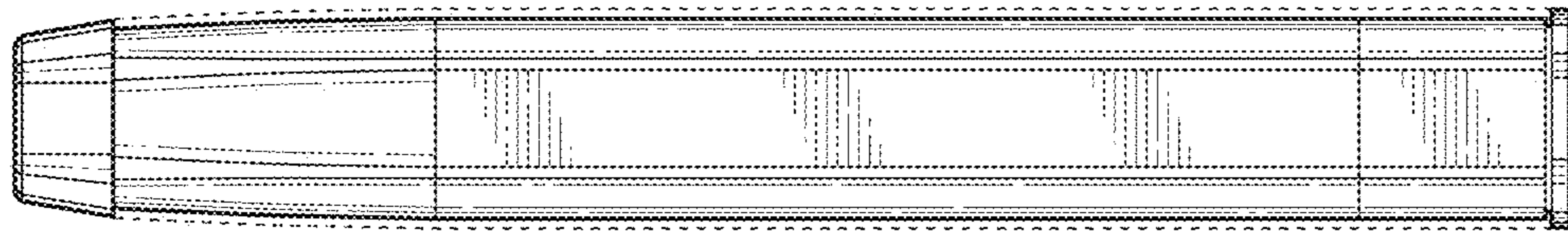

FIG. 2

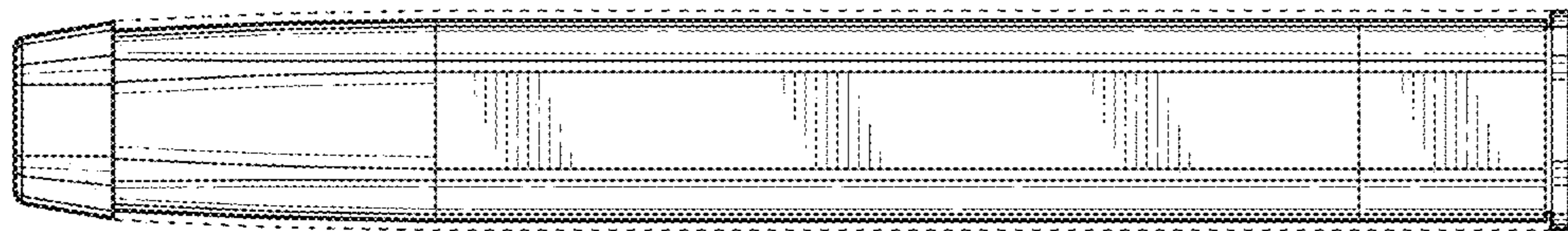

FIG. 3

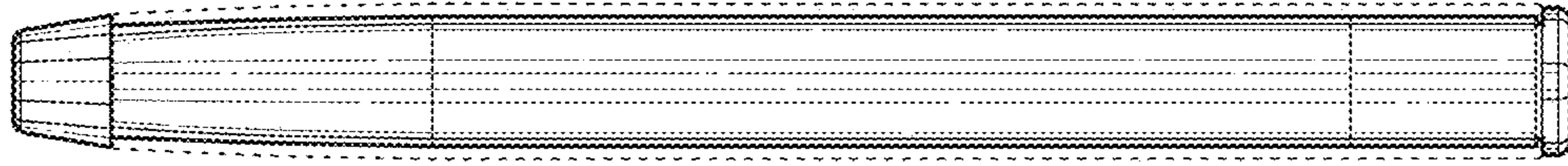

FIG. 4

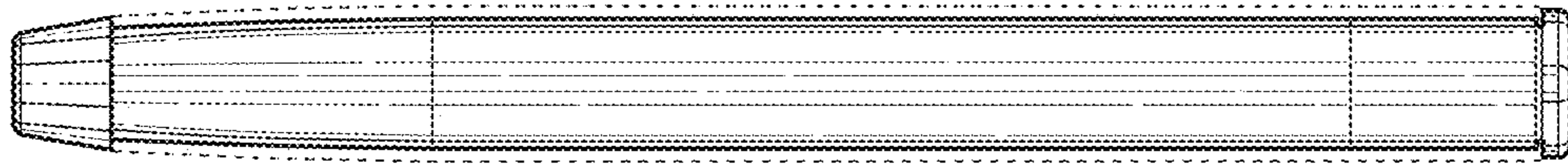

FIG. 5

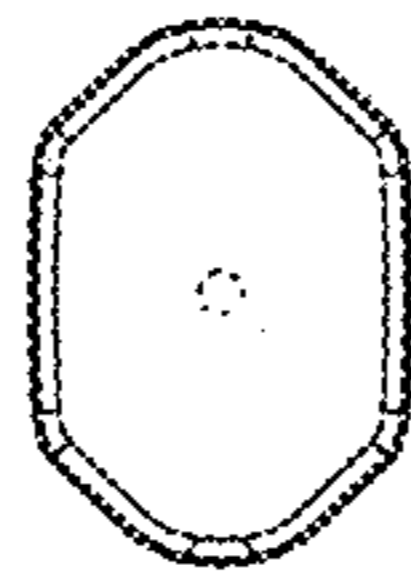

FIG. 6

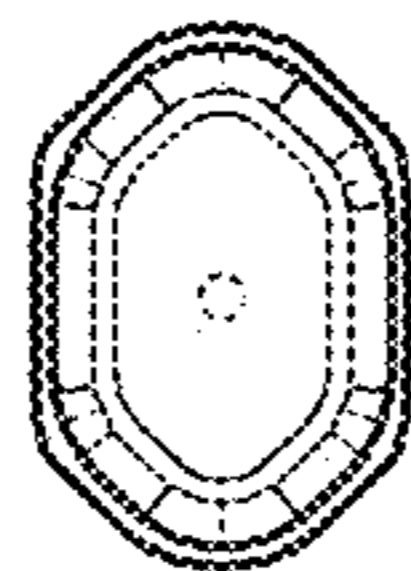

FIG. 7

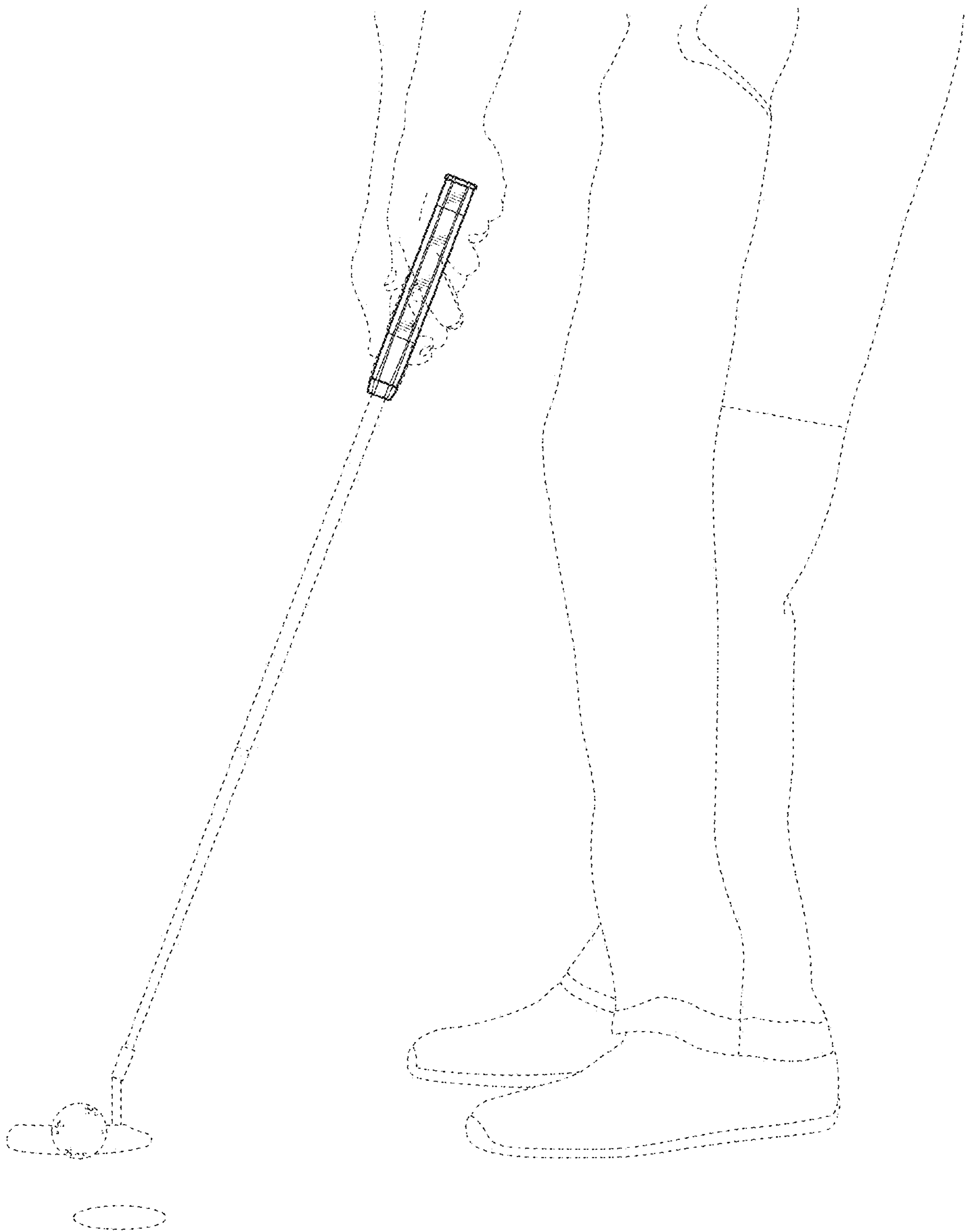

FIG. 8