



US00D890661S

(12) **United States Design Patent** (10) **Patent No.:** **US D890,661 S**
Alexiev (45) **Date of Patent:** **** Jul. 21, 2020**

(54) **VEHICLE DASHBOARD**
(71) Applicant: **McLaren Automotive Limited**,
Woking, Surrey (GB)
(72) Inventor: **Alexandar Bojidarov Alexiev**, Woking
(GB)
(73) Assignee: **McLaren Automotive Limited**,
Woking, Surrey (GB)

D622,195 S * 8/2010 Lester D12/192
D809,967 S * 2/2018 Lampkin D12/16
D825,420 S * 8/2018 Boyes D12/192
D826,814 S * 8/2018 Von Holzhausen D12/192
D843,288 S * 3/2019 Fontaeus D12/192
D863,167 S * 10/2019 Moir D12/192
D864,066 S * 10/2019 Ray D12/192
D864,817 S * 10/2019 Donfrancesco D12/192
D874,371 S * 2/2020 Buffery D12/192
D877,012 S * 3/2020 Ali D12/192

(**) Term: **15 Years**
(21) Appl. No.: **29/670,597**
(22) Filed: **Nov. 16, 2018**

OTHER PUBLICATIONS

[No Author Listed] Photograph of Model Year 1993 McLaren F1 Dashboard. 1 page.

* cited by examiner

(30) **Foreign Application Priority Data**
May 17, 2018 (GB) 6035466
(51) **LOC (12) Cl.** **12-16**
(52) **U.S. Cl.**
USPC **D12/192**
(58) **Field of Classification Search**
USPC D12/192, 415, 114, 345; D15/17, 28;
D10/46, 98, 102-103, 122-12; D23/324
CPC B60H 1/34; B60H 1/3407; B60H 1/3414;
B60H 1/3421; B60H 1/3428; B60H
1/3435; B60H 1/3442; B60H 1/345;
B60H 1/3457; B60H 2001/3464; B60H
2001/3471; B60H 2001/3478; B60H
2001/3485
See application file for complete search history.

Primary Examiner — Katrina A Betton
(74) *Attorney, Agent, or Firm* — Wolf, Greenfield & Sacks, P.C.

(57) **CLAIM**

The ornamental design for a vehicle dashboard, as shown and described.

DESCRIPTION

FIG. 1 is a top, front, left side perspective view of a vehicle dashboard showing our new design; FIG. 2 is a front elevation view thereof; and, FIG. 3 is a top plan view thereof. The dash-dash broken lines illustrate portions of the dashboard that form no part of the claimed design. The dash-dash lines illustrating a steering wheel show environmental matter that forms no part of the claimed design. The dot-dash broken lines are borders of the claimed design and form no part of the claimed design.

(56) **References Cited**
U.S. PATENT DOCUMENTS
D210,770 S * 4/1968 Geiger et al. D12/192
D480,671 S * 10/2003 Pfeiffer D12/192

1 Claim, 3 Drawing Sheets

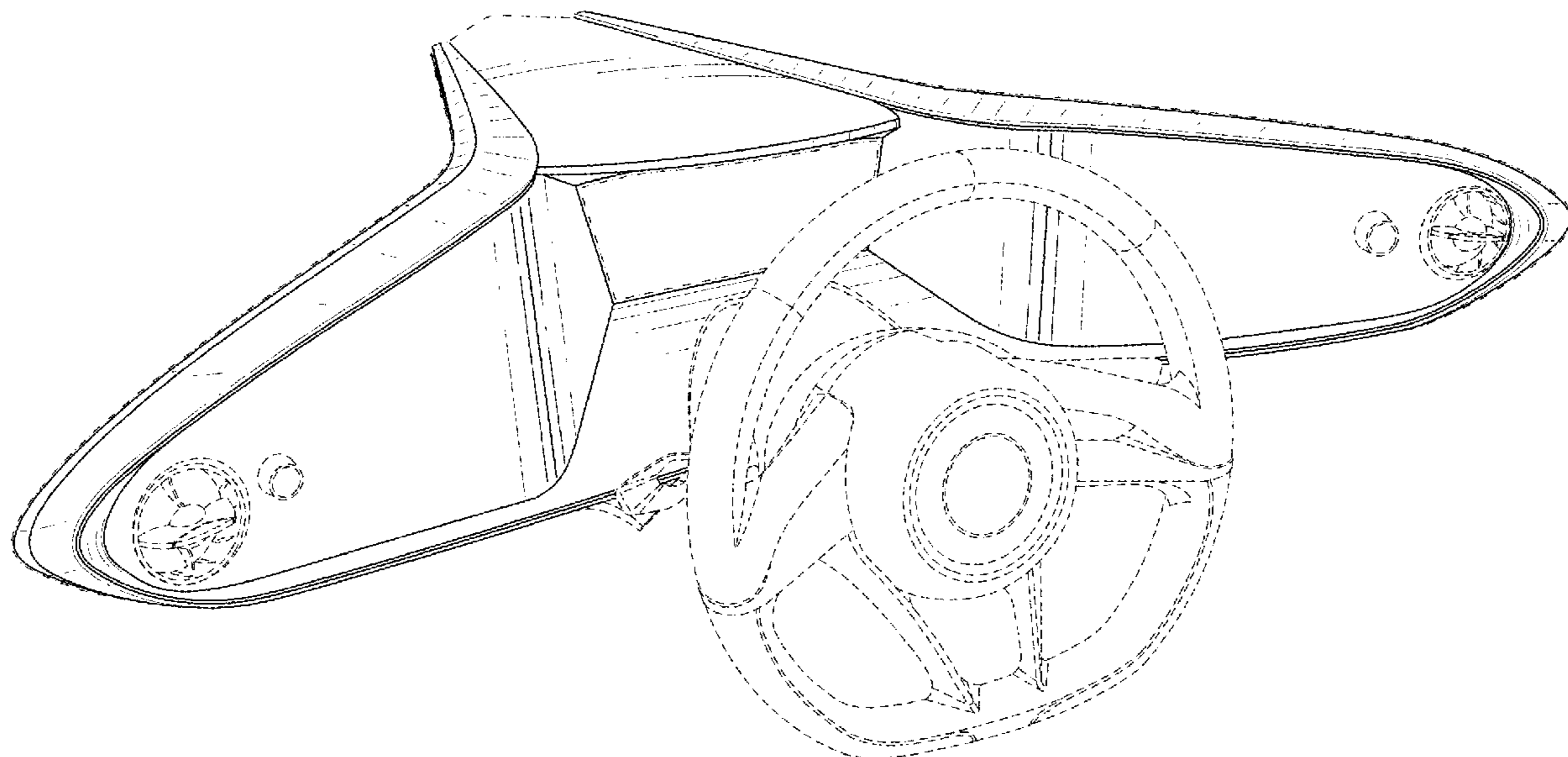

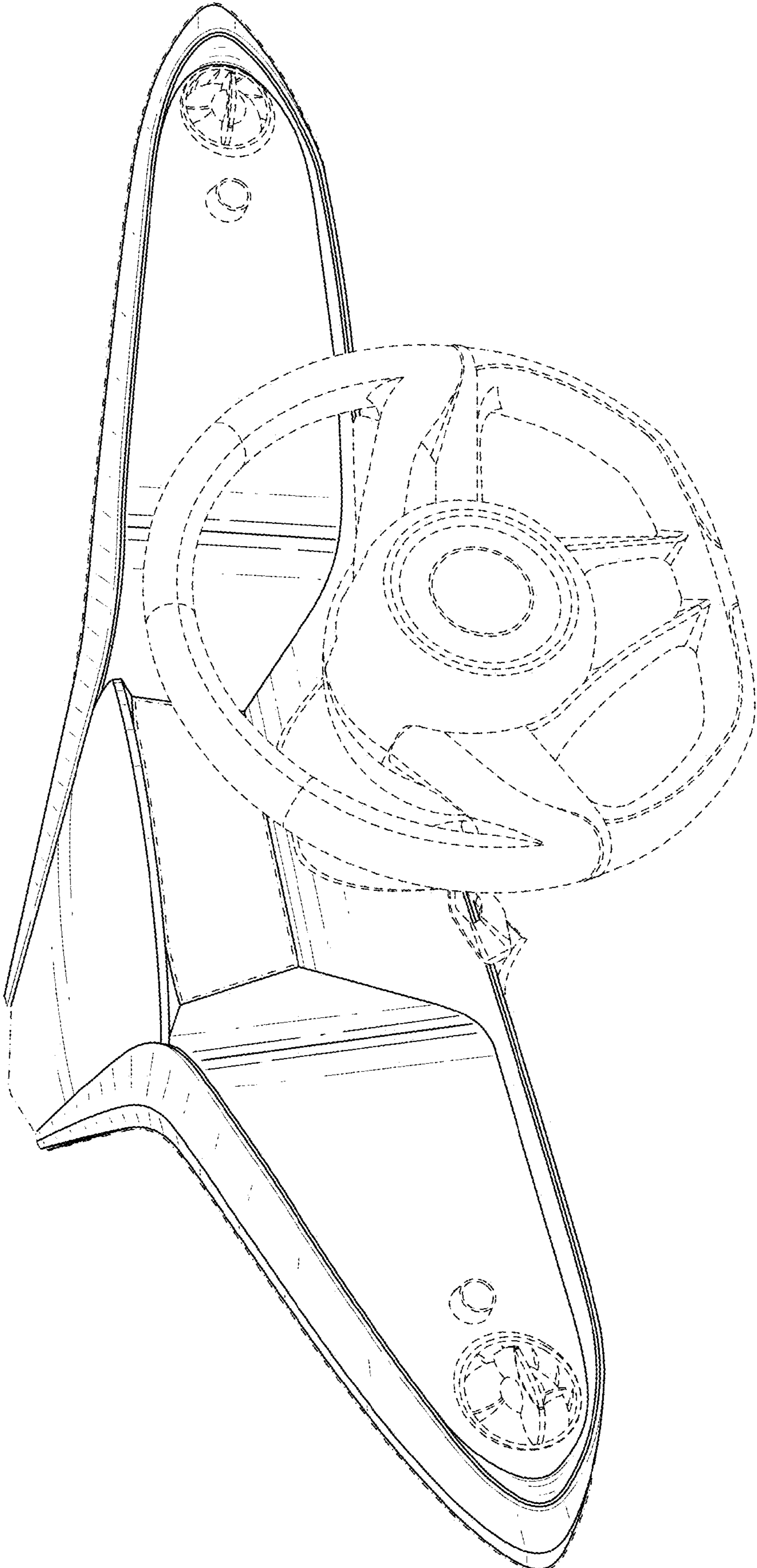

FIG. 1

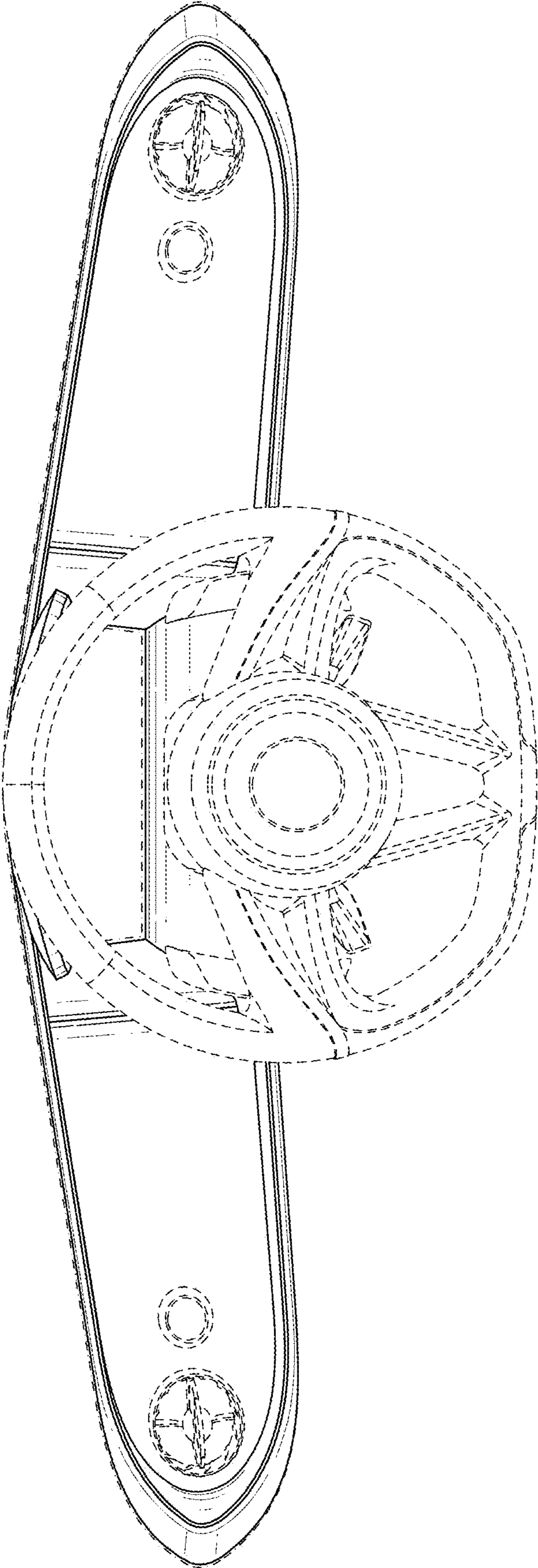

FIG. 2

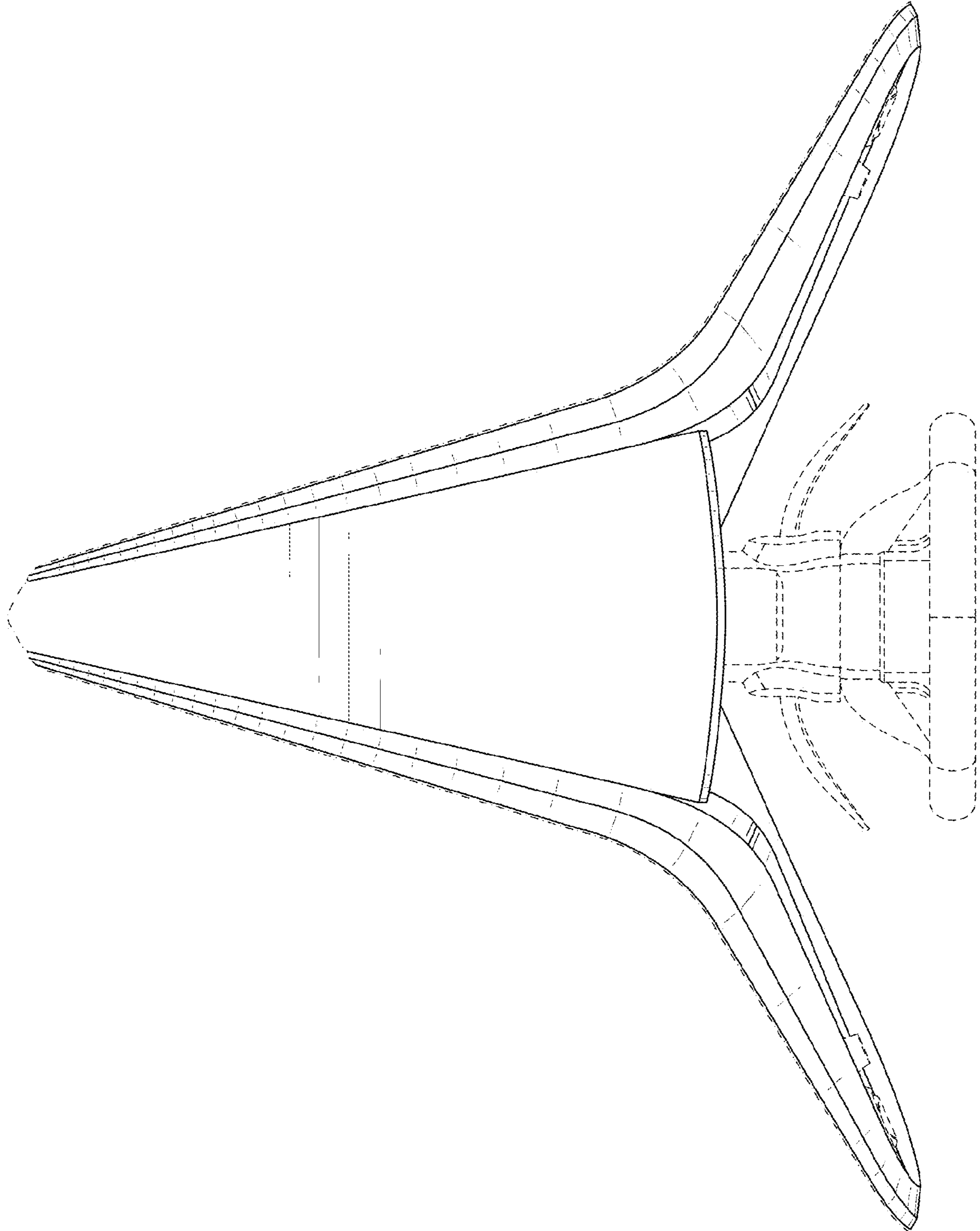

FIG. 3