



US00D890658S

(12) **United States Design Patent** (10) **Patent No.:** **US D890,658 S**
Ninov et al. (45) **Date of Patent:** **** Jul. 21, 2020**

(54) **FRONT FENDER**

(71) Applicants: **Deyan Ninov**, Royal Oak, MI (US);
Everard J Scott, Sterling Heights, MI
(US); **Michael Gillam**, Oxford, MI
(US); **Gregory A. Howell**, Farmington,
MI (US)

(72) Inventors: **Deyan Ninov**, Royal Oak, MI (US);
Everard J Scott, Sterling Heights, MI
(US); **Michael Gillam**, Oxford, MI
(US); **Gregory A. Howell**, Farmington,
MI (US)

(73) Assignee: **FCA US LLC**, Auburn Hills, MI (US)

(**) Term: **15 Years**

(21) Appl. No.: **29/673,410**

(22) Filed: **Dec. 14, 2018**

Related U.S. Application Data

(63) Continuation-in-part of application No. 29/626,553,
filed on Nov. 17, 2017, now Pat. No. Des. 837,099,
and a continuation-in-part of application No.
29/626,566, filed on Nov. 17, 2017, now Pat. No. Des.
836,036, and a continuation-in-part of application No.
29/626,563, filed on Nov. 17, 2017, now Pat. No. Des.
836,035, and a continuation-in-part of application No.
29/626,557, filed on Nov. 17, 2017, now Pat. No. Des.
836,034.

(51) **LOC (12) Cl.** **12-16**

(52) **U.S. Cl.**
USPC **D12/184**

(58) **Field of Classification Search**

USPC D12/184, 196, 90-92, 181; 280/152.1,
280/847-849, 851; 296/181.1, 181.5
CPC B62D 25/16; B62D 25/18; B62D 25/161;
B62D 25/168; B62D 25/184; B62D
25/186; B62D 25/188; D62D 25/182
See application file for complete search history.

(56) **References Cited**

U.S. PATENT DOCUMENTS

D854,989	S	*	7/2019	Sarremejean	D12/184
D855,520	S	*	8/2019	Parkinson	D12/184
D855,522	S	*	8/2019	Thogersen	D12/184
D864,812	S	*	10/2019	Dewitt	D12/184
D864,813	S	*	10/2019	Dewitt	D12/184
D873,740	S	*	1/2020	Zipfel	D12/184

* cited by examiner

Primary Examiner — Melody N. Brown

(74) *Attorney, Agent, or Firm* — Ralph E. Smith

(57) **CLAIM**

The ornamental design for a front fender, as shown and described.

DESCRIPTION

FIG. 1 is a front perspective view of a front fender showing our new design;

FIG. 2 is a side view thereof;

FIG. 3 is a front view thereof;

FIG. 4 is a rear view thereof;

FIG. 5 is a top view thereof; and,

FIG. 6 is a bottom view thereof.

It will be understood that the broken lines shown in the drawings illustrate portions of the front fender that form no part of the claimed design.

1 Claim, 6 Drawing Sheets

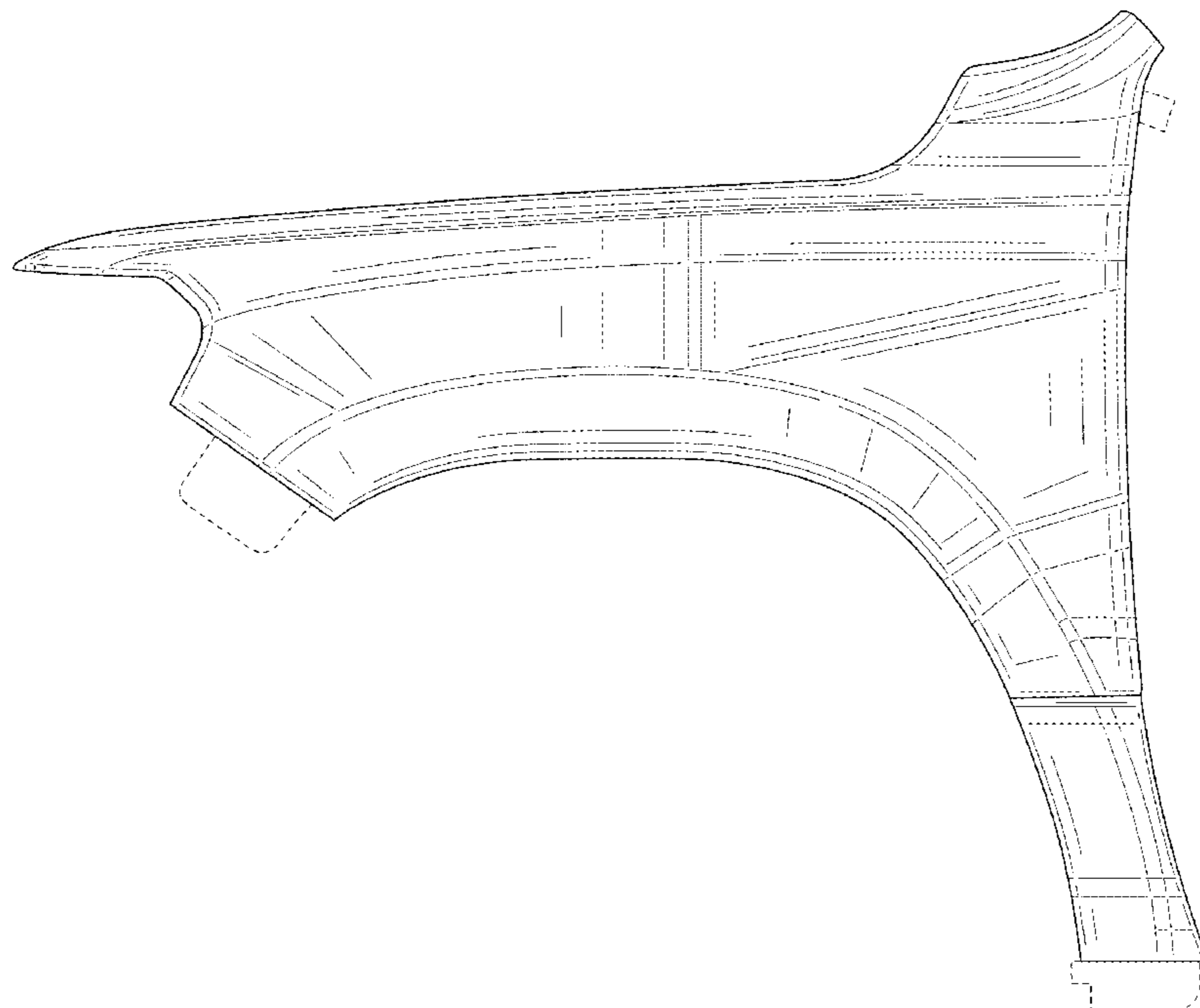

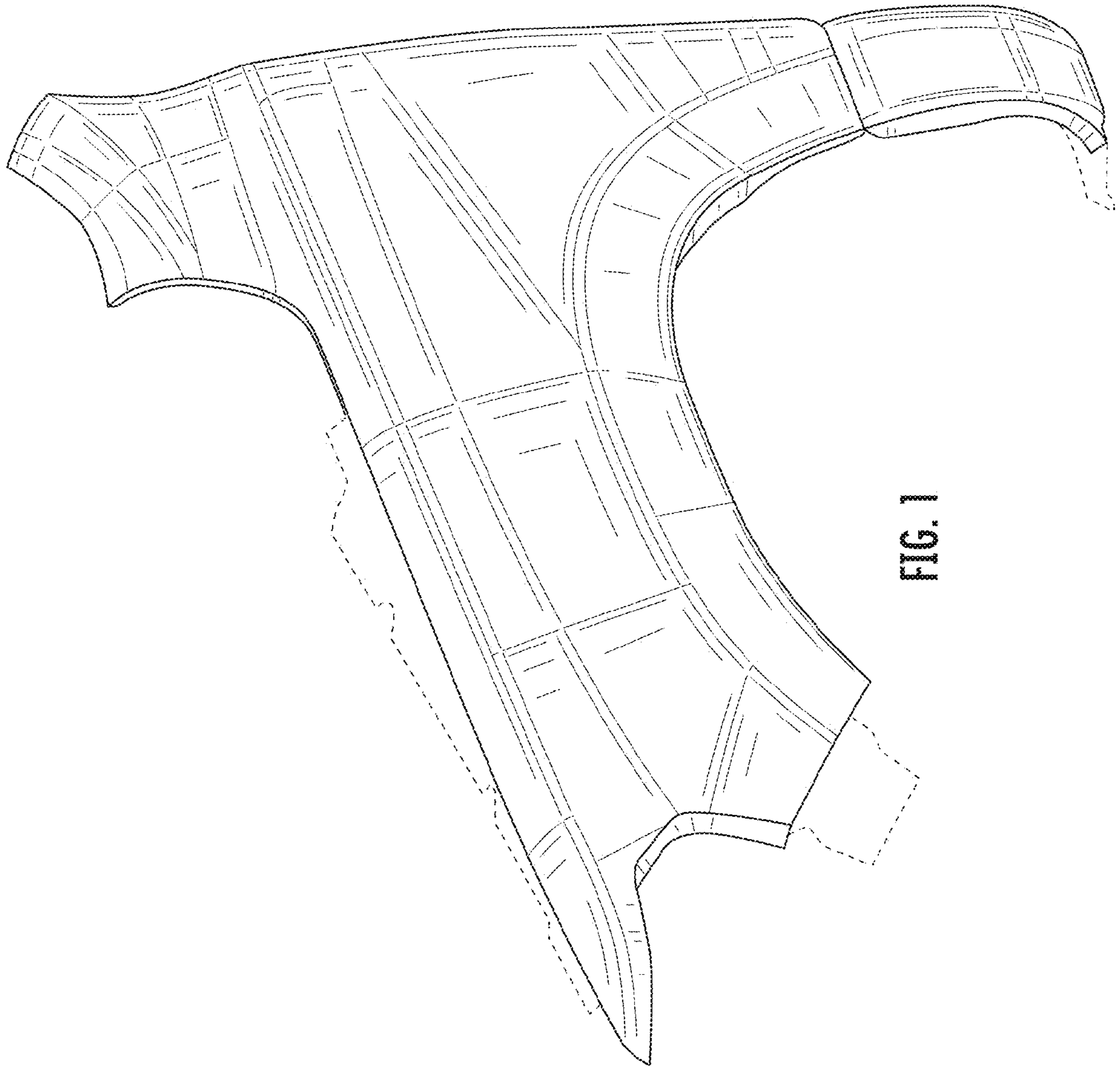

FIG. 1

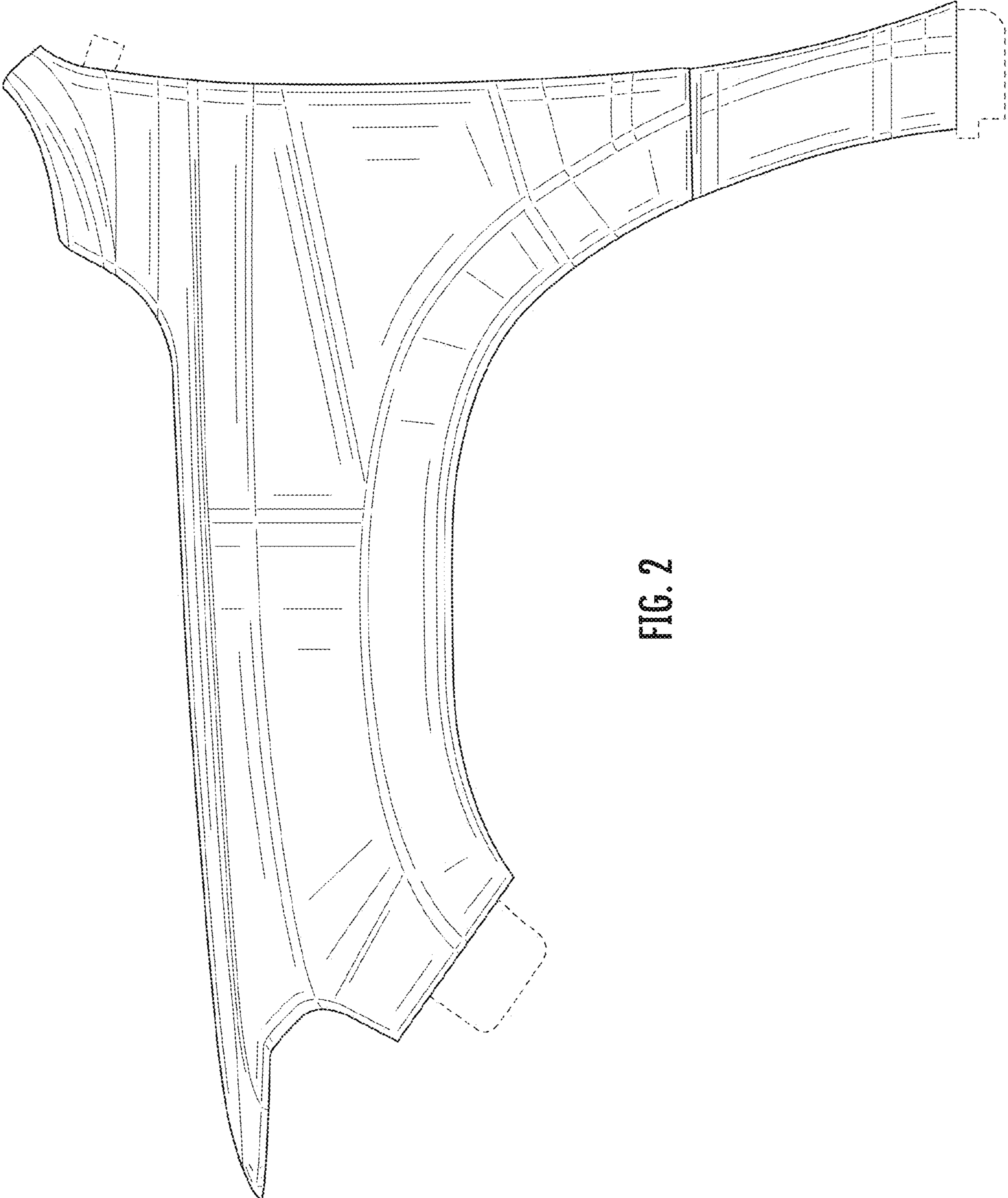

FIG. 2

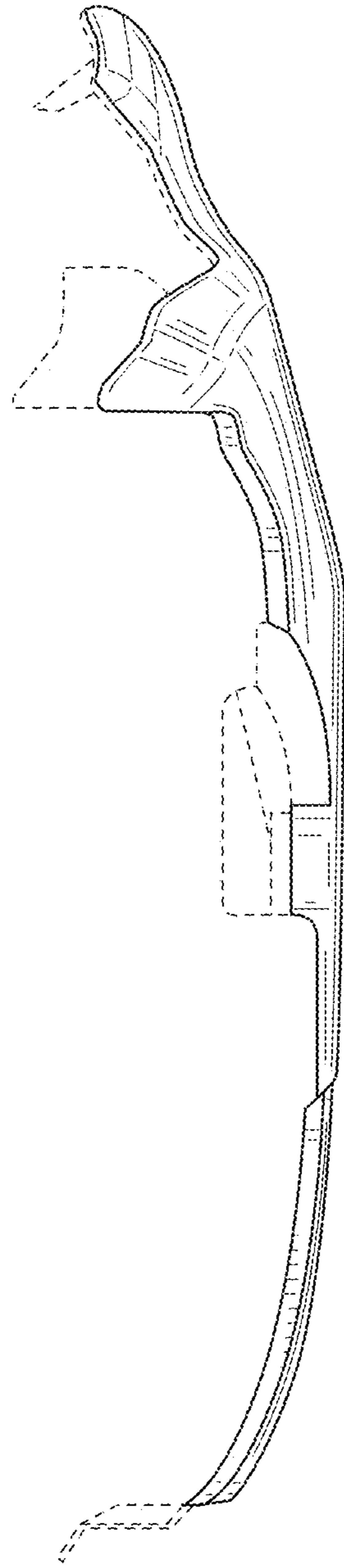

FIG. 3

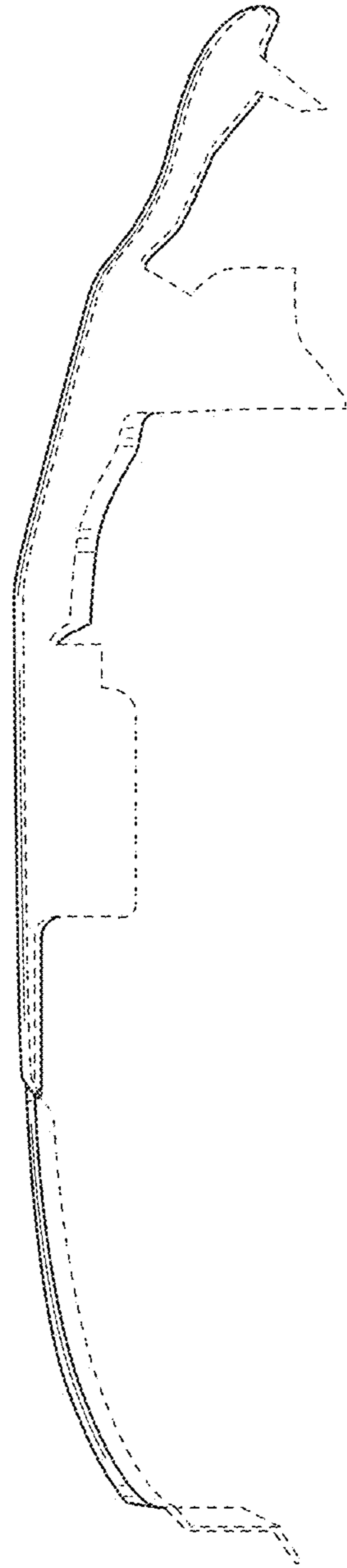

FIG. 4

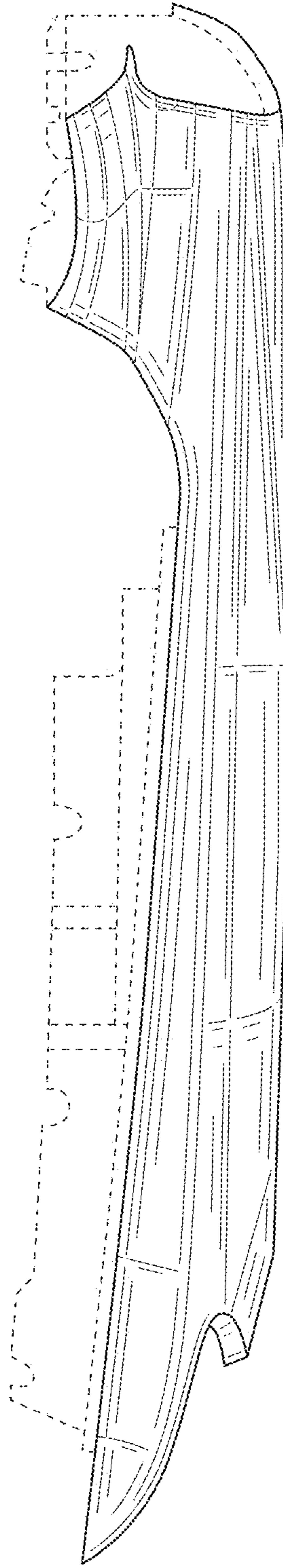

FIG. 5

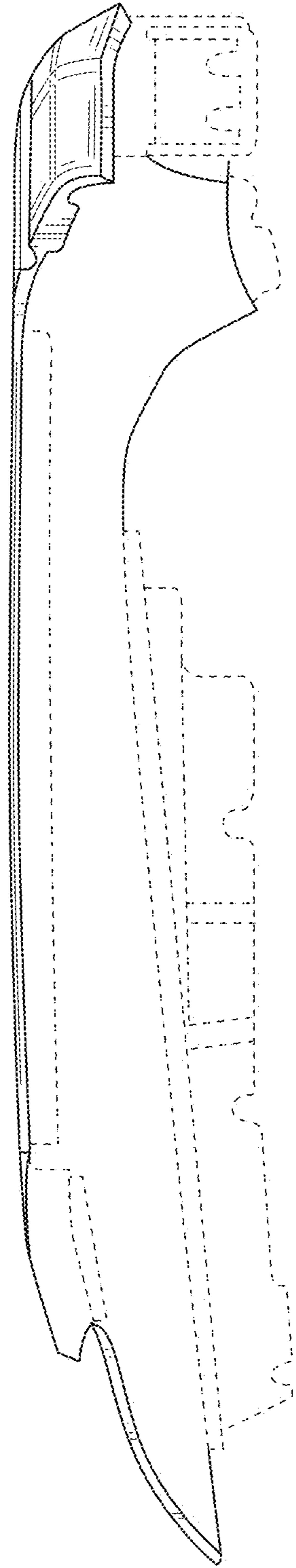

FIG. 6