



US00D890362S

(12) **United States Design Patent** (10) **Patent No.:** **US D890,362 S**  
**Bruemmer et al.** (45) **Date of Patent:** **\*\* Jul. 14, 2020**

(54) **ANNULAR MAGNET HOUSING**

(71) Applicant: **Wavesense, Inc.**, Irvine, CA (US)  
(72) Inventors: **Timothy M. Bruemmer**, Carmel, IN (US); **Bruce D. Irvine**, Concord, CA (US); **Christopher Feistel**, Laguna Beach, CA (US); **Pawel Juraszek**, Ladera Ranch, CA (US)  
(73) Assignee: **WAVESENSE, INC.**, Irvine, CA (US)

(\*\*) Term: **15 Years**

(21) Appl. No.: **29/690,363**

(22) Filed: **May 7, 2019**

(51) **LOC (12) Cl.** ..... **24-01**

(52) **U.S. Cl.**  
USPC ..... **D24/232**

(58) **Field of Classification Search**  
USPC ..... D24/107, 216, 219, 223–232, 121; D10/81  
CPC ..... B01L 3/5021; B01L 2300/042; B01L 2300/0832; B01L 2300/0851; B01L 2200/0631; B01L 2400/0409; B03C 1/005; B03C 1/01; B03C 1/025; B03C 1/027; B03C 1/10; B03C 1/145; B03C 1/30; B03C 2201/18; B03C 2201/26  
See application file for complete search history.

(56) **References Cited**

**U.S. PATENT DOCUMENTS**

D490,531 S \* 5/2004 Feldman ..... D24/219  
D679,831 S \* 4/2013 Greenizen ..... D24/227  
D683,046 S \* 5/2013 Yin ..... D24/230  
D729,662 S \* 5/2015 Gifford ..... D24/216  
2011/0023729 A1 \* 2/2011 Plaisted ..... B26D 7/088  
99/537  
2018/0127741 A1 \* 5/2018 Feistel ..... C12N 15/1013  
2019/0309245 A1 \* 10/2019 Shimagaki ..... C12M 23/34

**OTHER PUBLICATIONS**

Blanker, M, et al., Voided Volumes: Normal Values and Relation to Lower Urinary Tract Symptoms in Elderly Men, A Community-Based Study, *Urology*, 2001, 57: 1093-1099.  
Chen, Peng, et al., Inkjet-Print Micromagnet Array on Glass Slides for Immunomagnetic Enrichment of Circulating Tumor Cells, *Annals of Biomedical Engineering*, Aug. 20, 2015, 44 (5): 1710-1720.  
Chen, Peng, et al., Microscale Magnetic Field Modulation for Enhanced Capture and Distribution of Rare Circulating Tumor Cells, *Scientific Reports*, Mar. 4, 2015, 5: 8745.

(Continued)

*Primary Examiner* — Anhdao Doan

(74) *Attorney, Agent, or Firm* — Stetina Brunda Garred and Brucker

(57) **CLAIM**

The ornamental design for an annular magnet housing, as shown and described.

**DESCRIPTION**

FIG. 1 is a top perspective view of an annular magnet housing in an environment in which it may be used; FIG. 2 is a top perspective view thereof; FIG. 3 is a bottom perspective view thereof; FIG. 4 is a top view thereof; FIG. 5 is a front view thereof, the left side, right side and rear being mirror images thereof; and, FIG. 6 is a bottom view thereof.

The broken lines depicting a sequestration device having a fluid reservoir connected thereto in FIG. 1 represent environmental structures form no part of the claimed design. The remaining broken lines depict portions of the annular magnet housing that form no part of the claimed design.

**1 Claim, 3 Drawing Sheets**

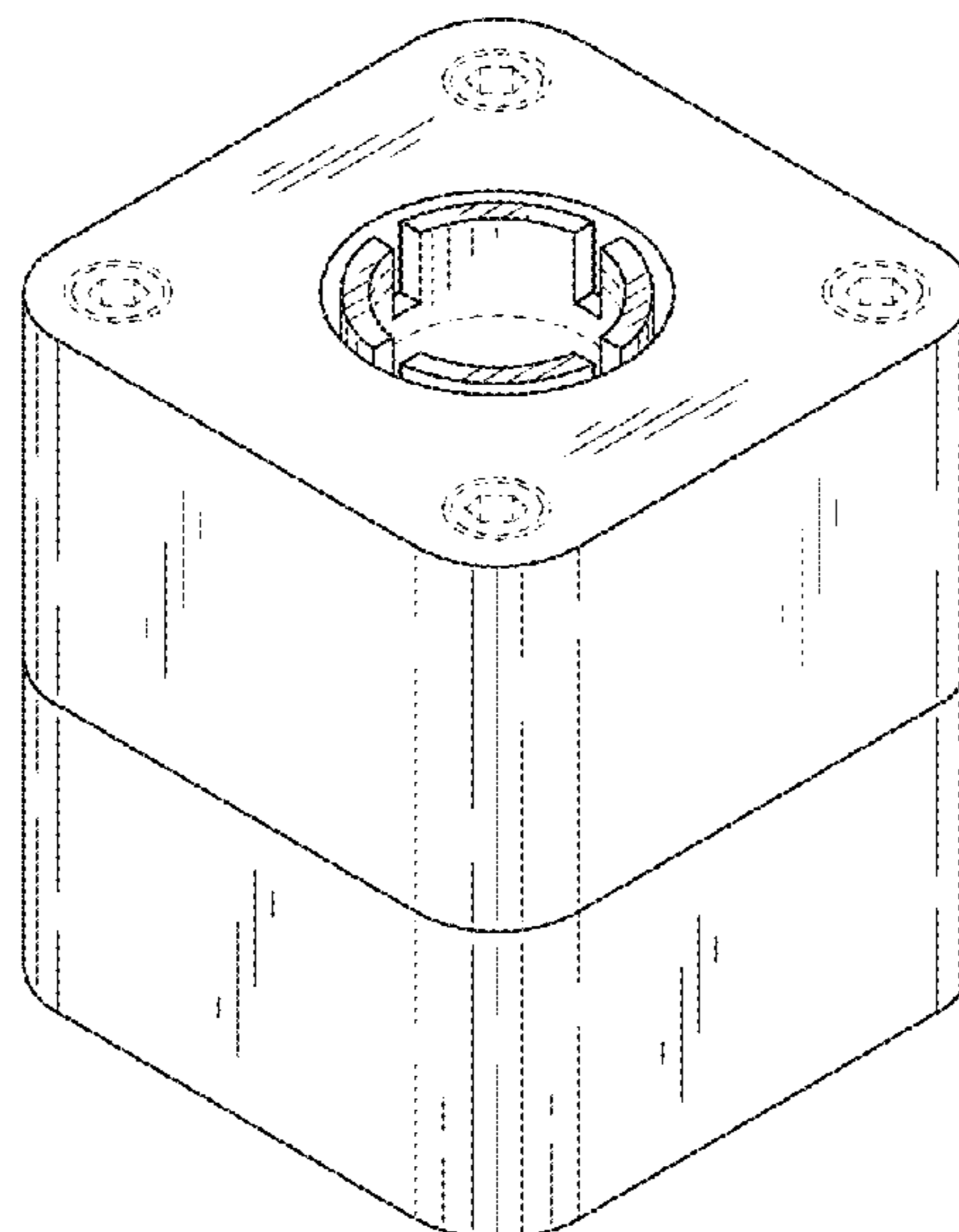

(56)

**References Cited**

## OTHER PUBLICATIONS

Desitter, I.; et al., A New Device for Rapid Isolation by Size and Characterization of Rare Circulating Tumor Cells, *Anticancer Research*, 2011, 31 (2): 427-442.

Esmailsabzail, H, et al., Detection and isolation of circulating tumor cells: principles and methods, *Biotechnol. Adv.*, 2013, 31 (7): 1063-84.

Hoshino, Kazunori, et al., Microchip-based immunomagnetic detection of circulating tumor cells, *Lab on a Chip*, Oct. 2011, 11 (20): 3449-3457.

Hoshino, Kazunori, et al., Computational Analysis of Microfluidic Immunomagnetic Rare Cell Separation from a Particulate Blood Flow, *Analytical Chemistry*, May 15, 2012, 84 (10): 4292-4299.

Huang, Yu-Yen, et al., Screening and Molecular Analysis of Single Circulating Tumor Cells Using Micromagnet Array, *Scientific Reports*, Nov. 5, 2015, 5: 16047.

Huang, Yu-yen, et al., Immunomagnetic nanoscreening of circulating tumor cells with a motion controlled microfluidic system, *Biomedical Microdevices*, Oct. 30, 2012, 15 (4): 673-681.

Luecke, Klaus, et al., The Gilupi Cellcollector as an in vivo tool for circulating tumor cell enumeration and molecular characterization

in lung cancer patients, *ASCO Annual Meeting Proceedings*, 2015, vol. 33, No. 15 suppl.

Paterlini-Brechot, P, et al., Circulating tumor cells (CTC) detection: Clinical impact and future directions, *Cancer Lett.*, 2007, 253 (2): 180-204.

Peng, Chen, et al., Multiscale immunomagnetic enrichment of circulating tumor cells: from tubes to microchips, *Lab on a Chip*, 2014, 14: 446-458.

Saucedo-Zeni, Nadia; et al., A novel method for the in vivo isolation of circulating tumor cells from peripheral blood of cancer patients using a functionalized and structured medical wire, *International Journal of Oncology*, 2012, 41 (4): 1241-1250.

Scheumann, N, et al., Numeration and molecular characterization of circulating tumor cells in lung cancer patients using the Gilupi Cellcollector, an effective in vivo device for capturing CTCS, *Annals of Oncology*, 2015, 26: 14.

Nagrath, Sunitha, et al., Isolation of rare circulating tumour cells in cancer patients by microchip technology, *Nature*, Dec. 2007, 450 (7173): 1235-1239.

Elsheikh, T., *Urine Cytology Challenges and Pitfalls*, [www.ahn.org/sites/default/files/file/elsheikh-2](http://www.ahn.org/sites/default/files/file/elsheikh-2).

\* cited by examiner

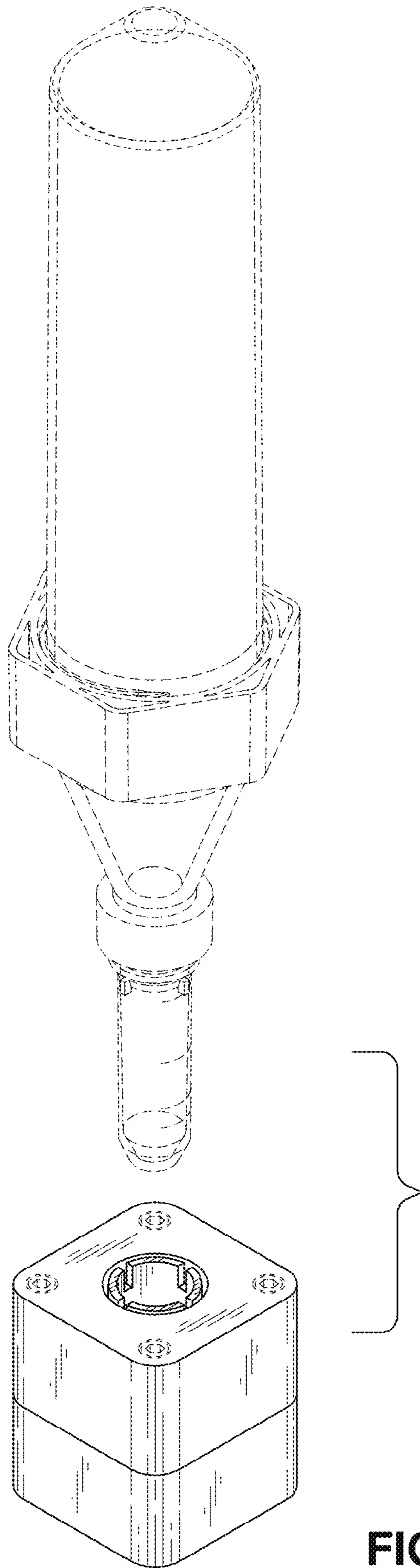
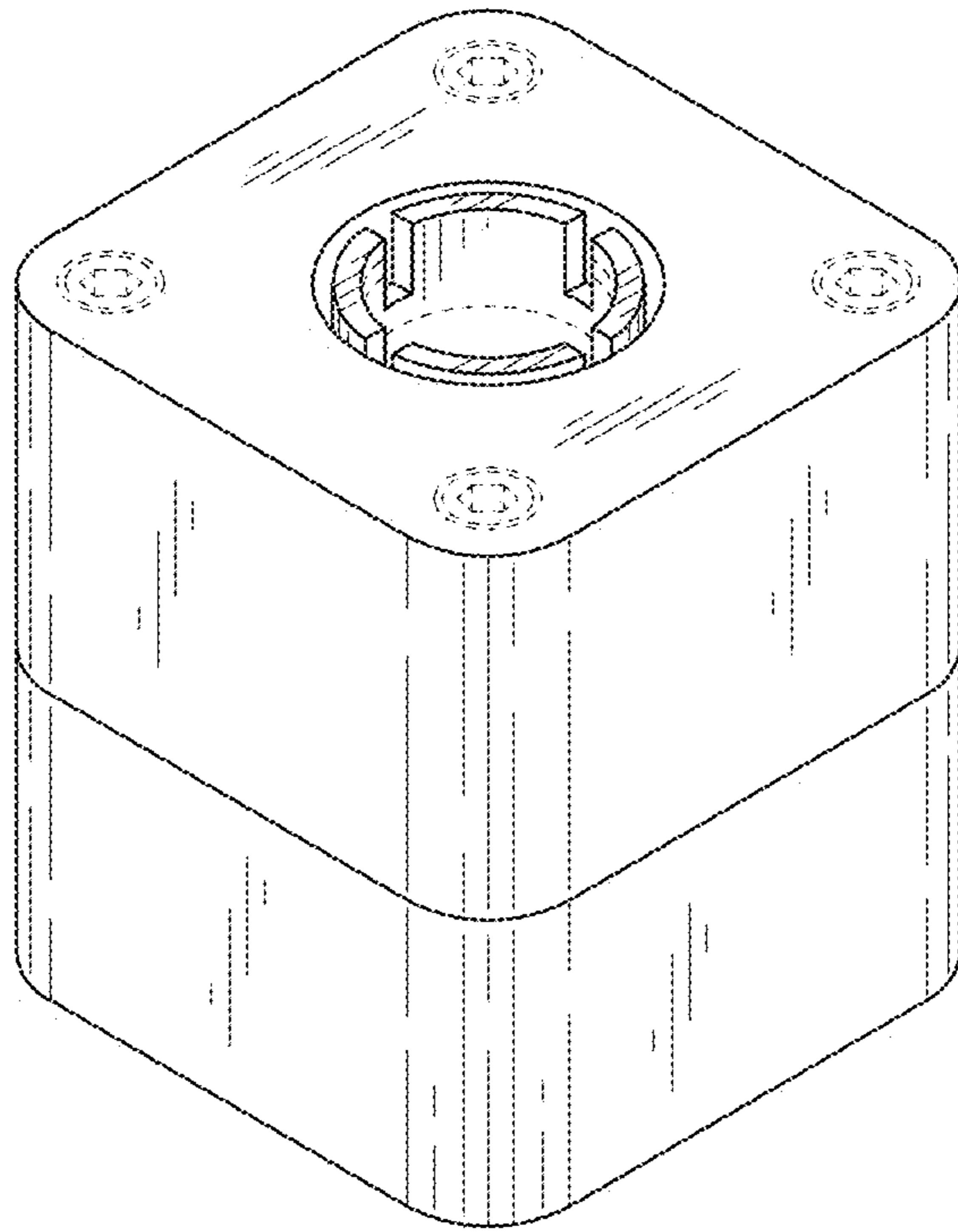
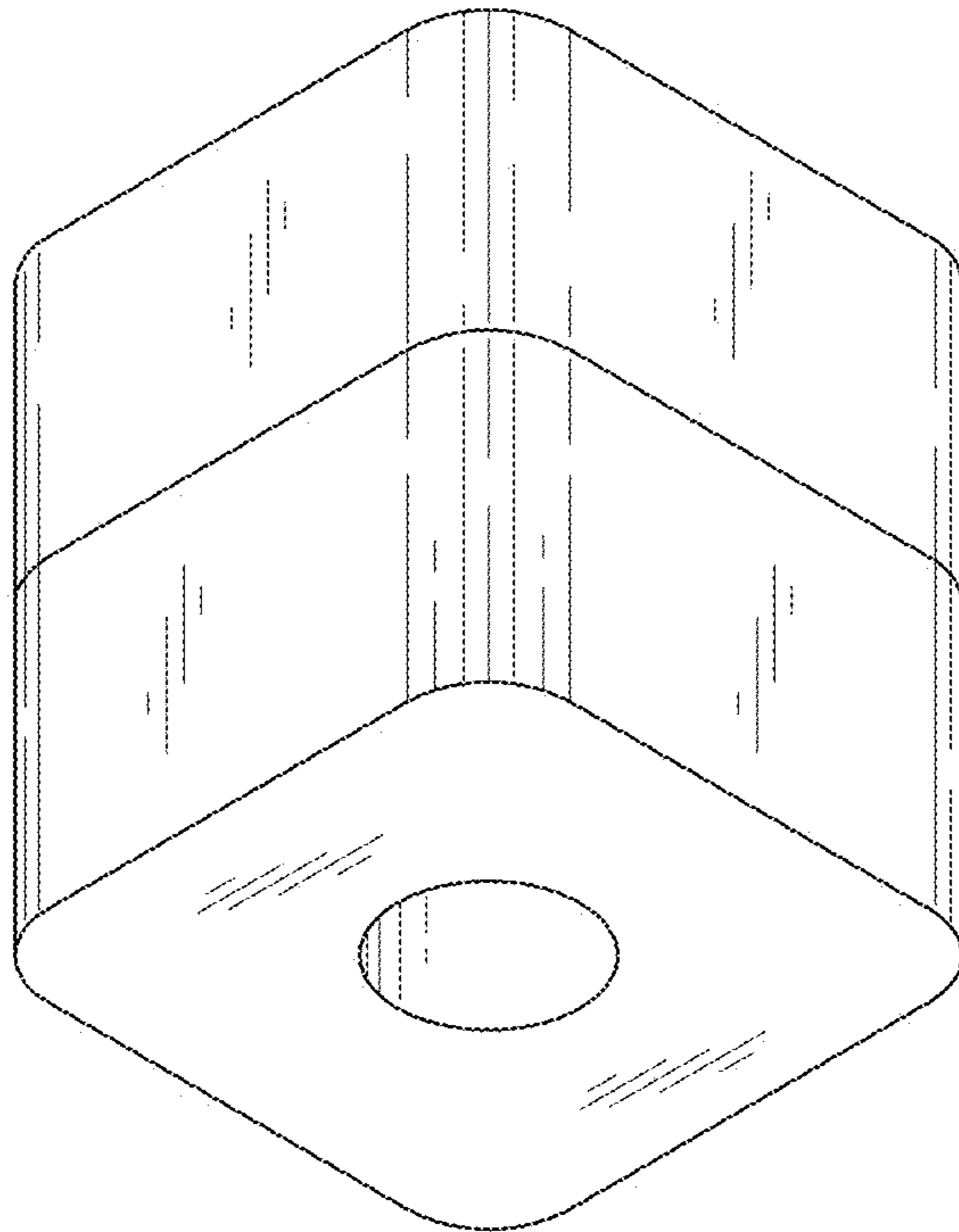

FIG. 1



**FIG. 2**



**FIG. 3**

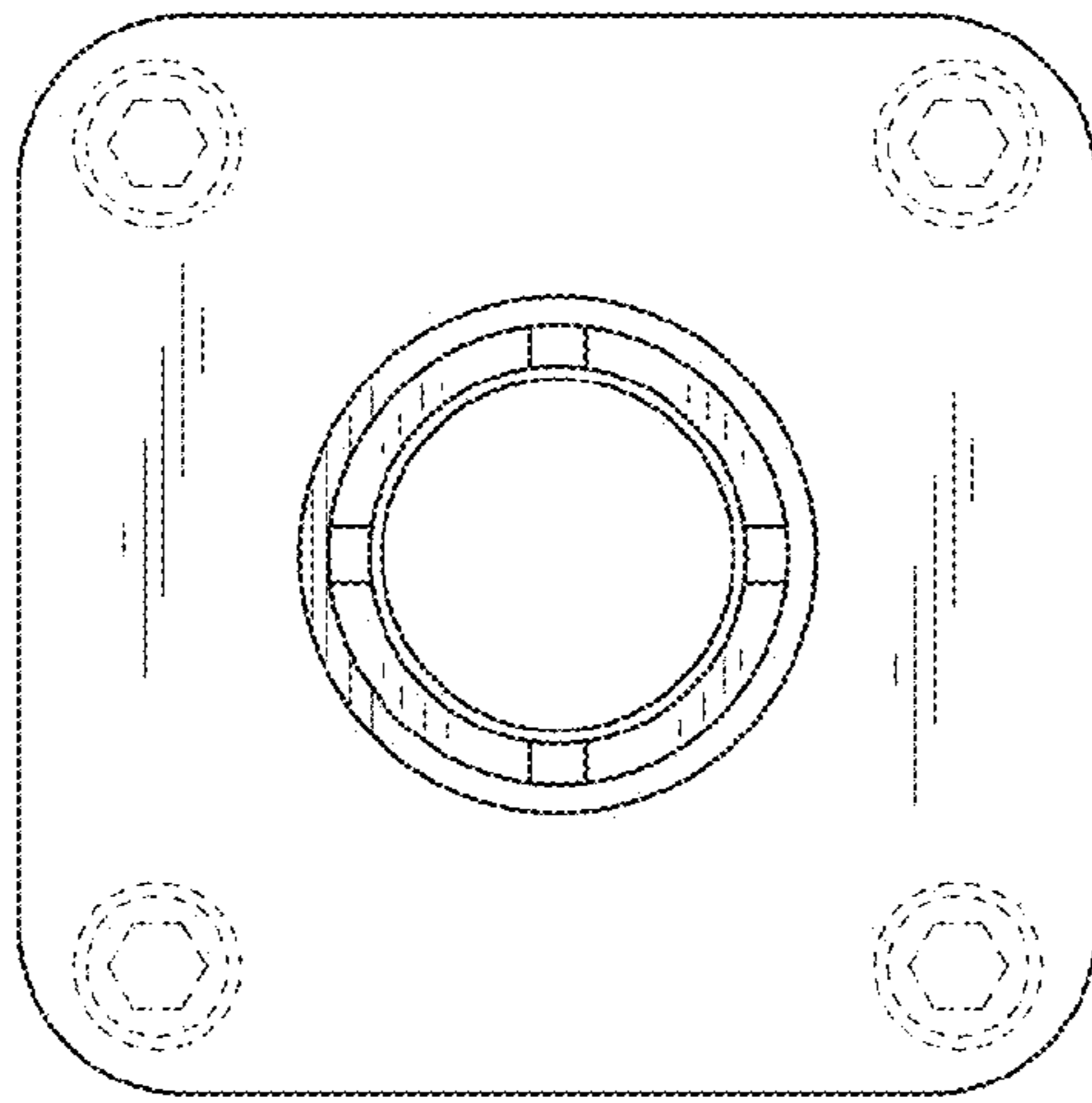

**FIG. 4**

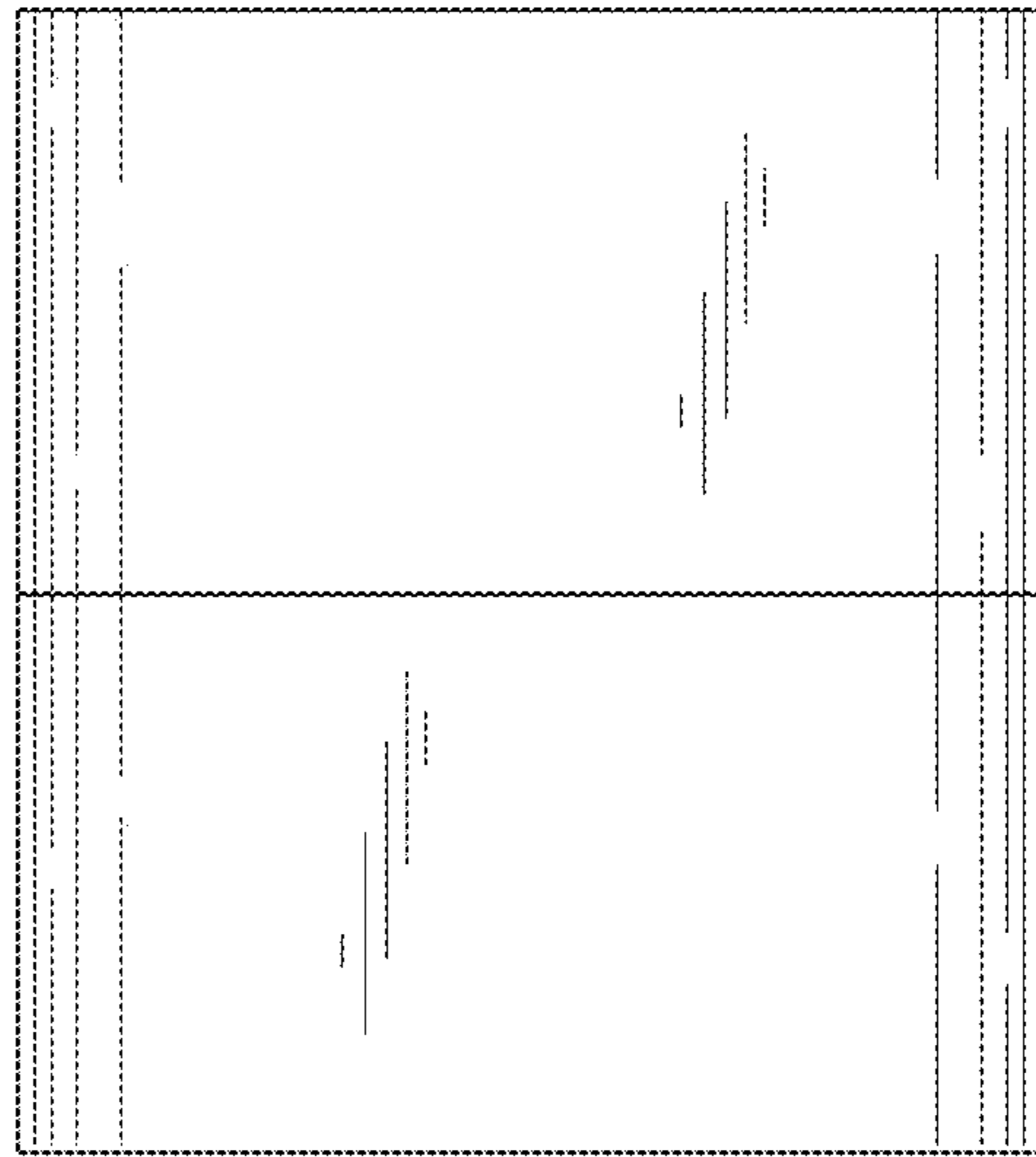

**FIG. 5**

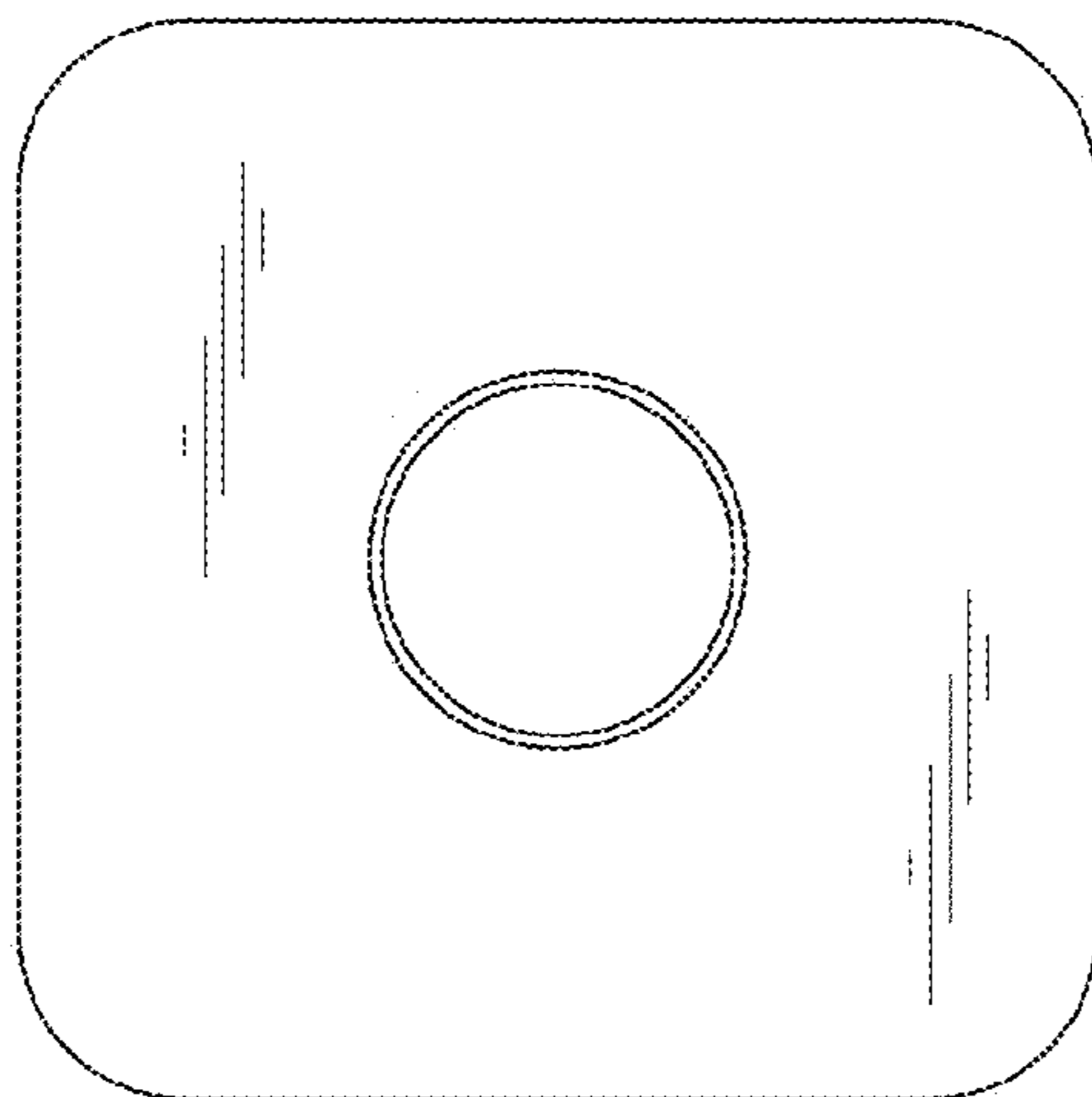

**FIG. 6**