



US00D890250S

(12) **United States Design Patent**  
**Gallegos et al.**

(10) **Patent No.:** **US D890,250 S**

(45) **Date of Patent:** **\*\* Jul. 14, 2020**

- (54) **UPRIGHT PIANO**
- (71) Applicant: **Steinway Musical Instruments, Inc.**,  
New York, NY (US)
- (72) Inventors: **Marco Gallegos**, Berlin (DE); **Robert Polan**, Floral Park, NY (US)
- (73) Assignee: **Steinway Musical Instruments, Inc.**,  
New York, NY (US)

1,623,188 A *	4/1927	Hurst	.....	G10C 3/02	84/177
D143,501 S *	1/1946	Nields	.....	D17/7	
D318,285 S *	7/1991	Dong	.....	D17/7	
D597,587 S *	8/2009	Bailey	.....	D17/7	
D774,127 S *	12/2016	Mitsuishi	.....	D17/7	
D814,556 S *	4/2018	Liu	.....	D17/7	
D849,828 S *	5/2019	Liu	.....	D17/7	
2019/0147835 A1 *	5/2019	Fukatsu	.....	G10C 1/02	84/179

(\*\*) Term: **15 Years**

(21) Appl. No.: **29/662,431**

(22) Filed: **Sep. 5, 2018**

(51) **LOC (12) Cl.** ..... **17-01**

(52) **U.S. Cl.**  
USPC ..... **D17/7**

(58) **Field of Classification Search**  
USPC ..... D17/1, 2, 7-9; D21/405  
CPC ... G10C 1/00; G10C 1/02; G10C 1/04; G10C  
3/00; G10C 3/12  
See application file for complete search history.

(56) **References Cited**

**U.S. PATENT DOCUMENTS**

890,443 A *	6/1908	Norcross	.....	G10C 3/00	84/178
D45,520 S *	3/1914	Bjur	.....	D17/7	
D45,729 S *	5/1914	Smith	.....	D21/409	

\* cited by examiner

*Primary Examiner* — R. Johnson

(74) *Attorney, Agent, or Firm* — Fish & Richardson P.C.

(57) **CLAIM**

The ornamental design for an upright piano, as shown and described.

**DESCRIPTION**

FIG. 1 is a front, right side perspective view of an upright piano, showing my new design;  
 FIG. 2 is a top view thereof;  
 FIG. 3 is a front view thereof;  
 FIG. 4 is a left side view thereof; and,  
 FIG. 5 is a right side view thereof.  
 The bottom and back views are not elements of the claimed design.  
 The broken lines represent the portions of the upright piano that form no part of the claimed design.

**1 Claim, 3 Drawing Sheets**

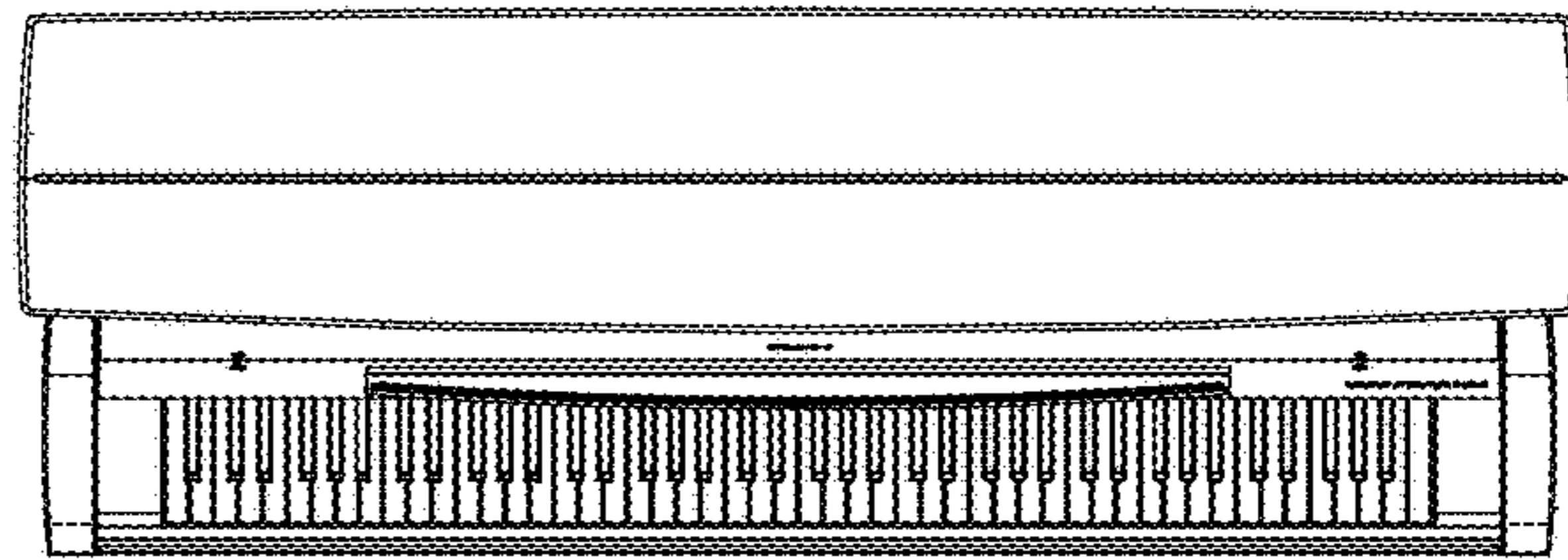
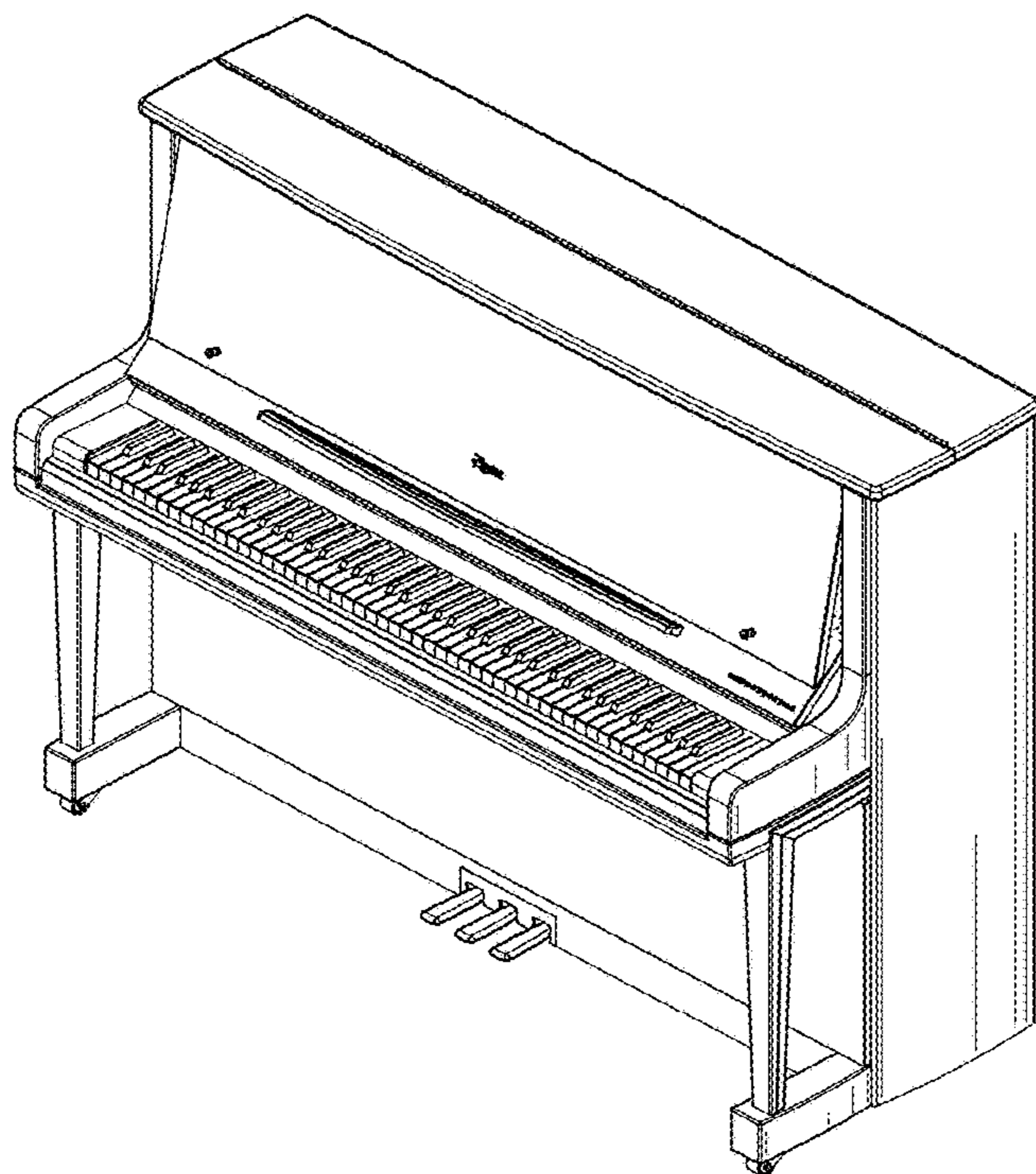

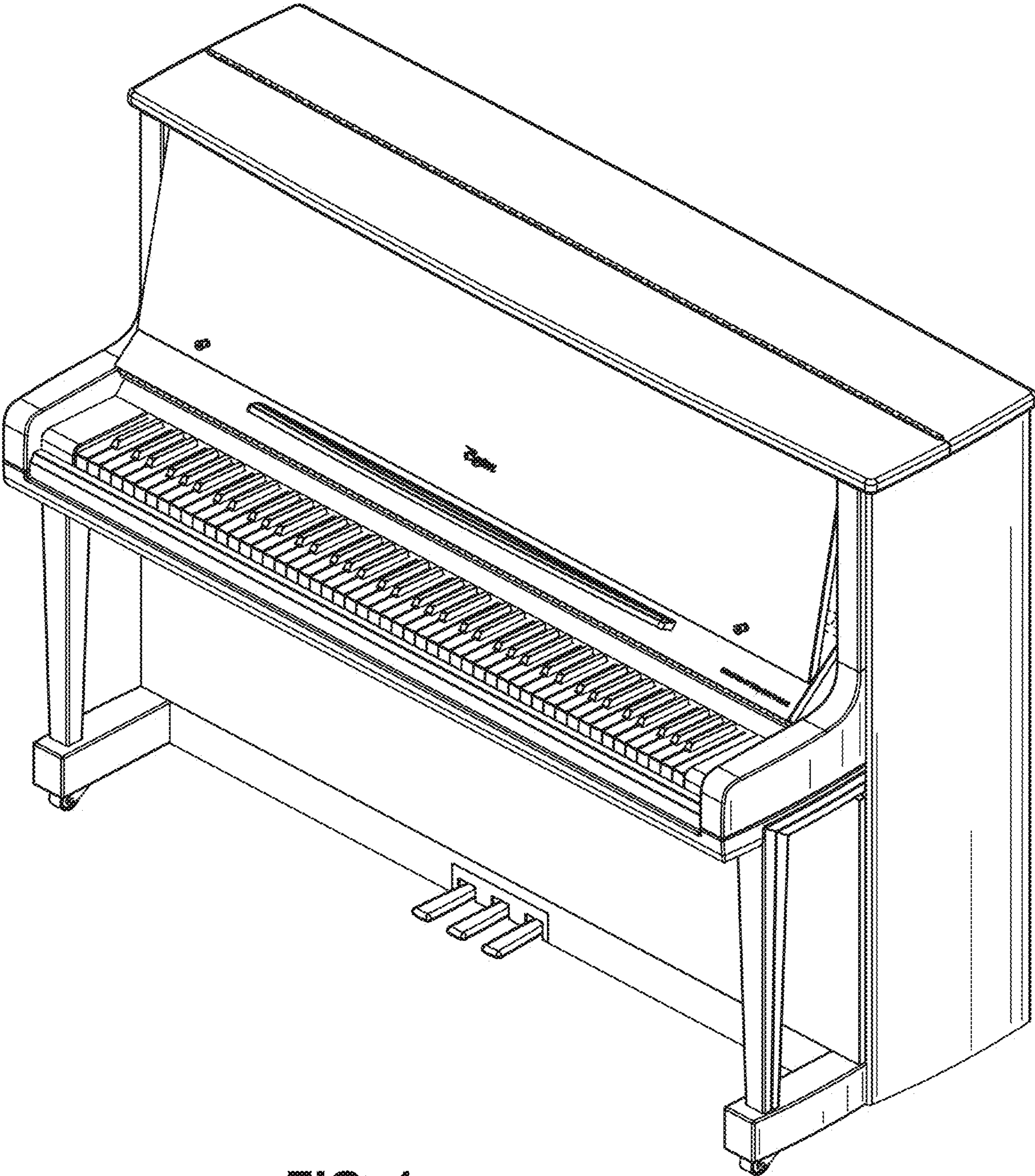

FIG. 1

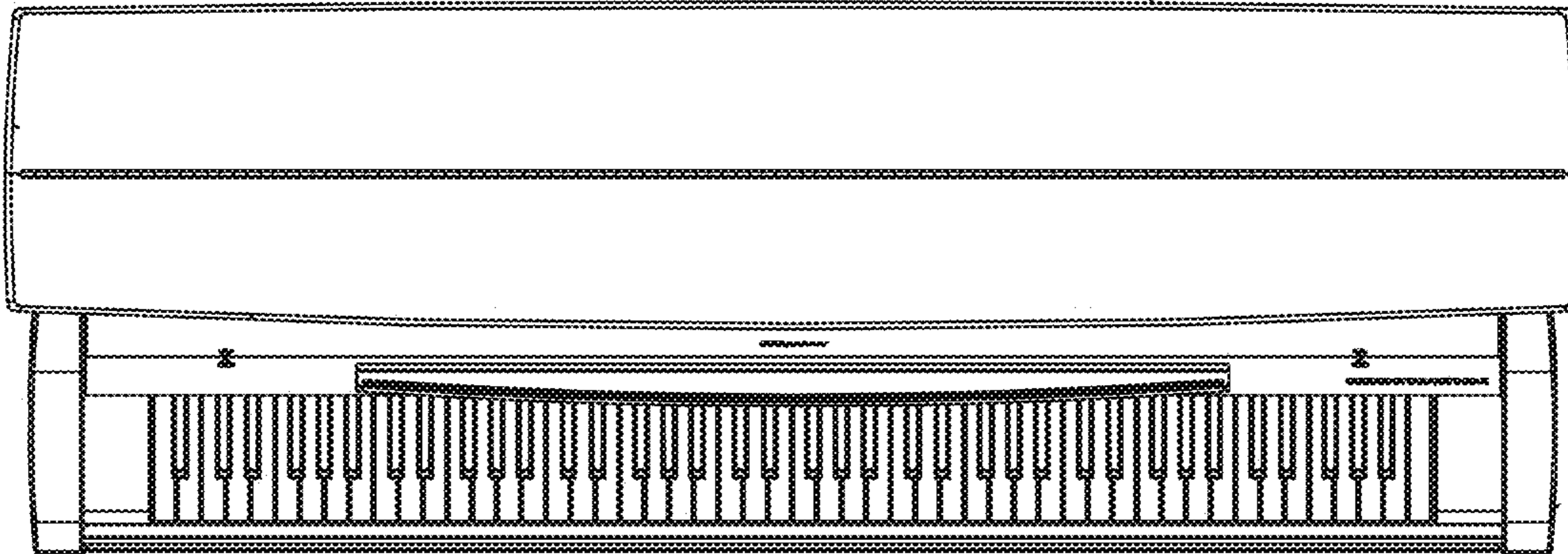

FIG. 2

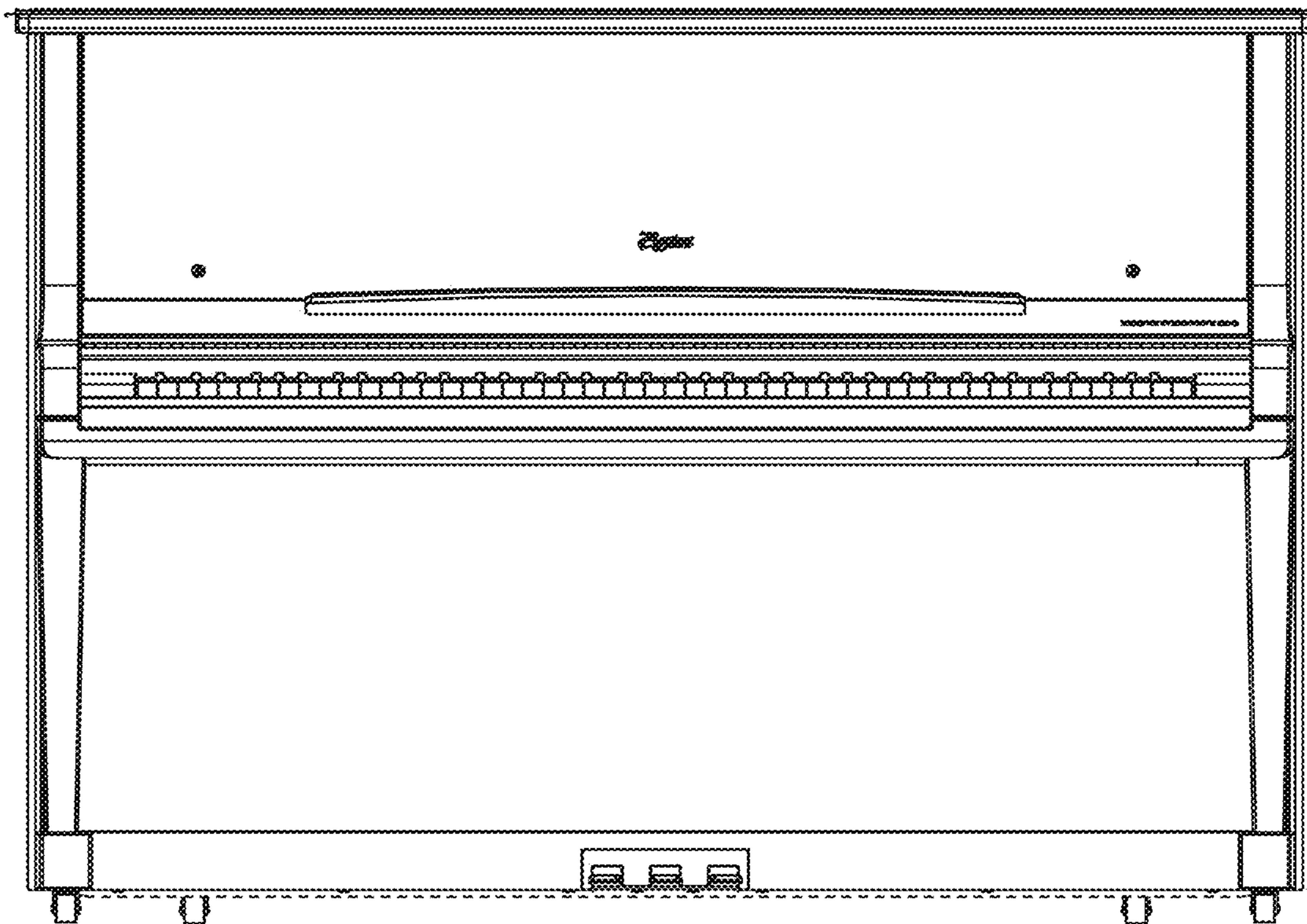

FIG. 3

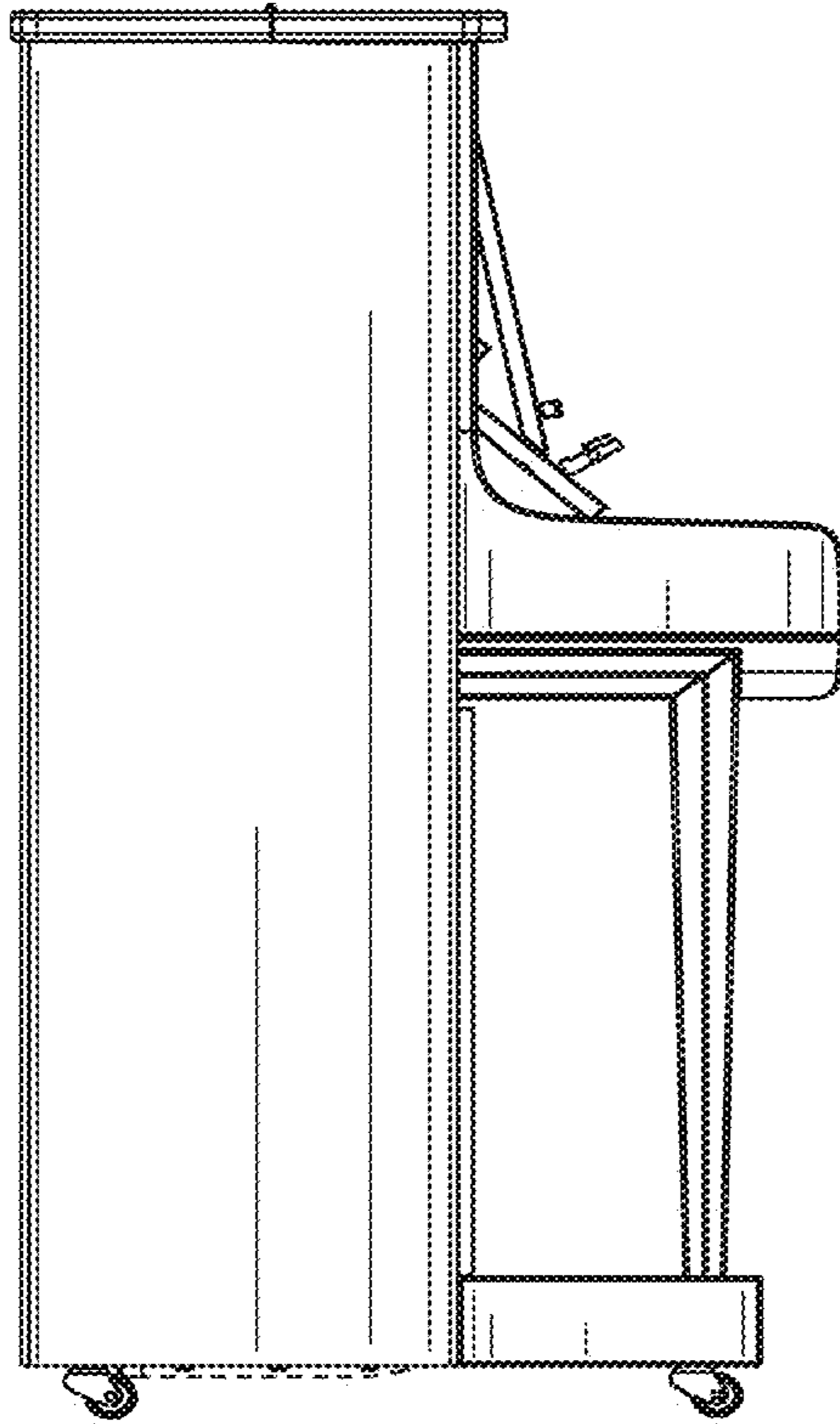

FIG. 4

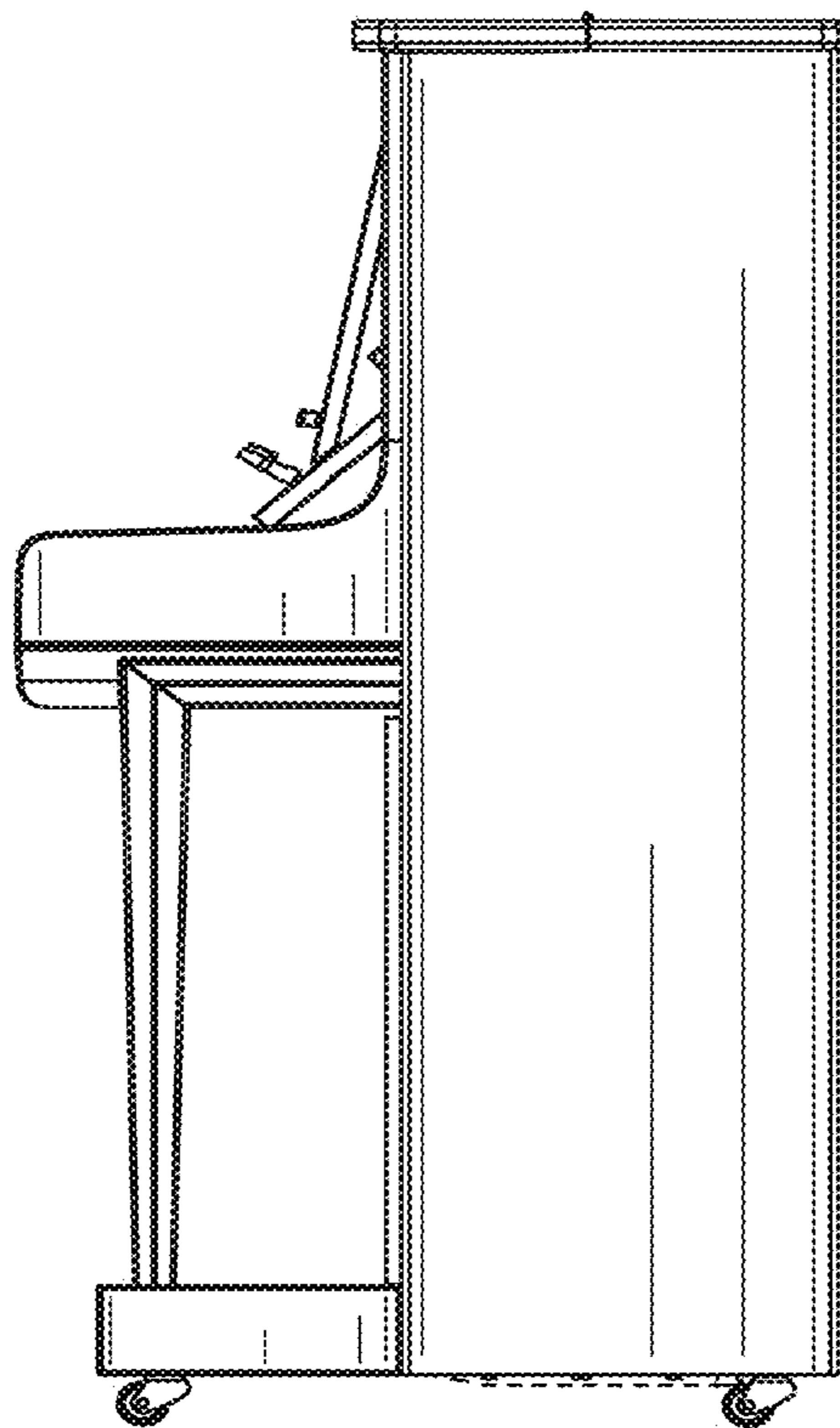

FIG. 5