



US00D889953S

(12) **United States Design Patent** (10) **Patent No.:** **US D889,953 S**  
**Lipfert et al.** (45) **Date of Patent:** **\*\* Jul. 14, 2020**

(54) **ORNAMENT ATTACHMENT CUP**

(71) Applicant: **TARGET BRANDS, INC.**,  
Minneapolis, MN (US)  
(72) Inventors: **Kim Lipfert**, Minneapolis, MN (US);  
**Terrence J. Hornsby, Jr.**, Minneapolis,  
MN (US)  
(73) Assignee: **TARGET BRANDS, INC.**,  
Minneapolis, MN (US)

(\*\*) Term: **15 Years**

(21) Appl. No.: **29/613,843**

(22) Filed: **Aug. 14, 2017**

(51) **LOC (12) Cl.** ..... **08-08**

(52) **U.S. Cl.**  
USPC ..... **D8/396**

(58) **Field of Classification Search**  
USPC ..... D8/349, 354, 382, 383, 394, 395, 396;  
D28/39, 40, 42, 43  
CPC ... A45D 8/12; A45D 8/04; A45D 8/20; A45D  
8/24; A45D 8/30; A47G 33/08; A47G  
33/10; A47G 2033/089; A47G 2033/0827  
See application file for complete search history.

(56) **References Cited**

**U.S. PATENT DOCUMENTS**

2,053,139	A	9/1936	Donovan et al.
2,063,924	A	12/1936	Hanko
2,521,394	A	9/1950	Minners
2,599,303	A	6/1952	Ward
3,126,895	A	3/1964	Leclabart
D210,860	S	4/1968	Franciscus et al.
3,386,070	A	5/1968	Jansson et al.
4,632,133	A	12/1986	Losenno

(Continued)

**FOREIGN PATENT DOCUMENTS**

DE 3239082 A1 4/1984

**OTHER PUBLICATIONS**

“Candle Clip-On Ornaments”, printed from <http://store.gianis.com/gm501r.html> available at least as early as Sep. 14, 2011 (1 page).

(Continued)

*Primary Examiner* — Steven J Cxyz  
(74) *Attorney, Agent, or Firm* — JoAnn M. Seaton;  
Griffiths & Seaton PLLC

(57) **CLAIM**

The ornamental design for an ornament attachment clip, as shown and described.

**DESCRIPTION**

FIG. 1 is a top, front perspective view of an ornament attachment clip shown in a closed position; FIG. 2 is a front view thereof; FIG. 3 is a rear view thereof; FIG. 4 is a right side view thereof; FIG. 5 is a left side view thereof; FIG. 6 is a top view thereof; and FIG. 7 is a bottom view thereof. FIG. 8 is a top, front perspective view of the ornament attachment clip, shown in use with environment; FIG. 9 is a top and front perspective view of the ornament attachment clip, shown in an open position; FIG. 10 is a front view thereof; FIG. 11 is a rear view thereof; FIG. 12 is a right side view thereof; FIG. 13 is a left side view thereof; FIG. 14 is a top view thereof; and, FIG. 15 is a bottom view thereof. In the drawings, the evenly-spaced broken lines depict portions of the article and environment that forms no part of the claimed design; the dash-dot-dash lines represent boundaries of the claimed design and form no part thereof.

**1 Claim, 13 Drawing Sheets**

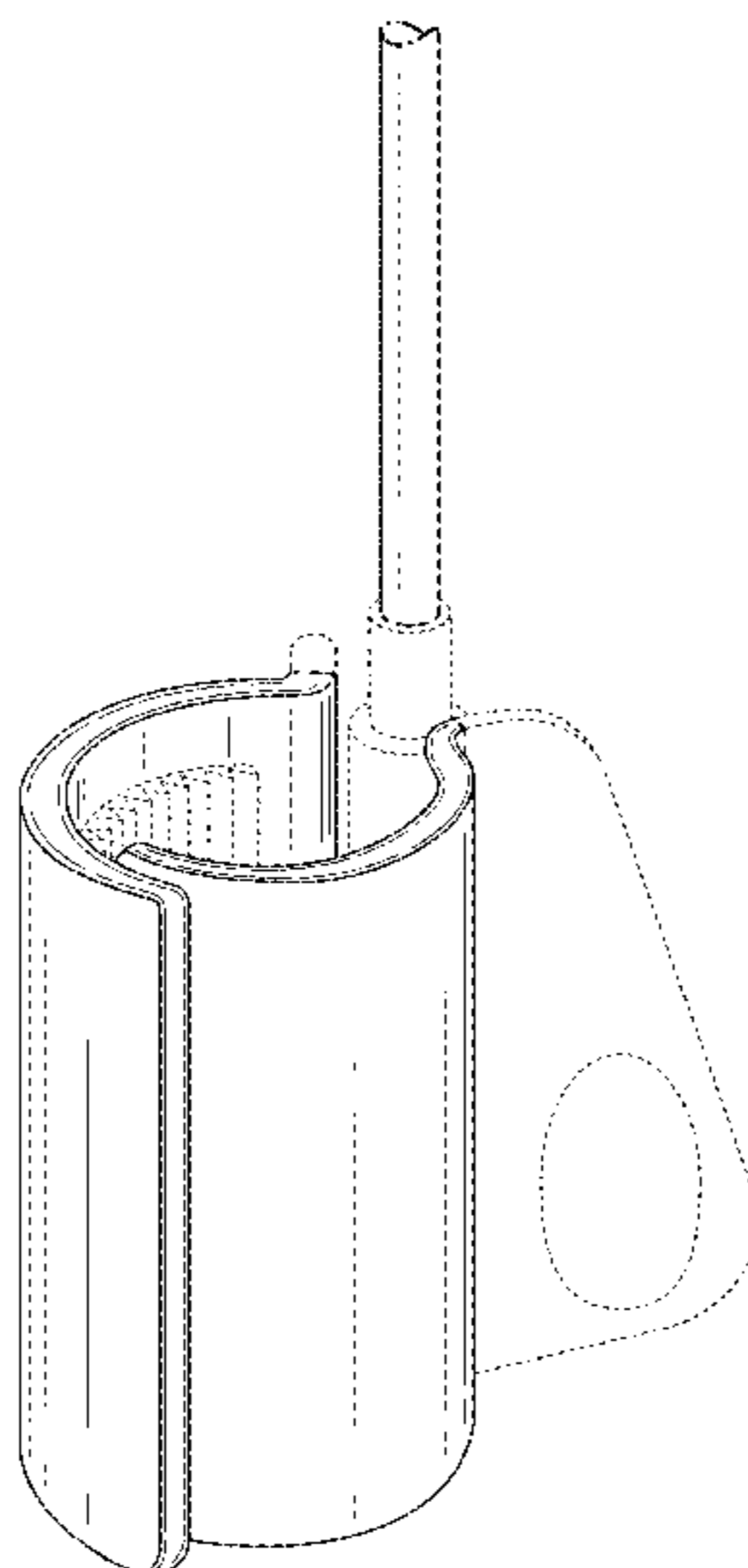

(56)

References Cited

U.S. PATENT DOCUMENTS

5,549,268 A 8/1996 Hopwood  
 5,787,905 A \* 8/1998 Yasuda ..... A45D 8/20  
 132/277  
 5,975,092 A \* 11/1999 Tsai ..... A45D 8/20  
 132/273  
 5,988,184 A \* 11/1999 Shu ..... A45D 8/20  
 132/129  
 6,035,863 A \* 3/2000 Mao ..... A45D 8/20  
 132/273  
 6,142,159 A 11/2000 Lloyd  
 6,360,752 B1 3/2002 Chang  
 D483,151 S 12/2003 Walker et al.  
 D483,524 S 12/2003 Walker et al.  
 D486,605 S 2/2004 Walker et al.  
 D488,258 S \* 4/2004 Walker ..... D28/40  
 7,066,185 B2 \* 6/2006 Hildebrandt ..... A45D 2/122  
 132/210  
 7,174,902 B2 \* 2/2007 Rizzuto ..... A45D 8/20  
 132/277  
 7,175,145 B2 2/2007 Simpson  
 7,299,808 B2 11/2007 Lau  
 7,419,277 B2 9/2008 Von Ronn et al.  
 7,419,283 B2 9/2008 Von Ronn et al.  
 D583,993 S 12/2008 Pichon  
 7,493,903 B2 2/2009 Rogers et al.  
 7,717,388 B2 \* 5/2010 Rizzo ..... A47G 33/10  
 248/231.81  
 D627,516 S \* 11/2010 Hsu ..... D28/40  
 8,025,066 B2 \* 9/2011 Silva ..... A45D 20/00  
 132/210  
 8,109,279 B2 2/2012 Chudzik et al.  
 8,186,364 B2 \* 5/2012 Silva ..... A45D 8/20  
 132/275  
 8,276,598 B1 \* 10/2012 Shepard ..... A45D 8/20  
 132/275  
 8,800,941 B2 8/2014 Kahn  
 8,863,761 B2 \* 10/2014 Wang ..... A45D 8/24  
 132/276  
 9,049,914 B2 6/2015 Sze  
 D736,075 S \* 8/2015 Forbes ..... D8/396  
 9,232,841 B1 \* 1/2016 Hsu ..... A45D 8/20  
 9,237,820 B2 \* 1/2016 Forbes ..... A47G 33/10

9,445,656 B2 9/2016 Hsu  
 D777,568 S \* 1/2017 Forbes ..... D8/394  
 D790,309 S 6/2017 Liao  
 9,924,772 B2 \* 3/2018 Hsu ..... A45D 8/20  
 10,051,937 B1 \* 8/2018 Wenzel ..... A45D 8/20  
 D829,990 S \* 10/2018 Hsu ..... D28/40  
 D831,273 S \* 10/2018 Sze ..... D28/40  
 2005/0199771 A1 9/2005 Simpson  
 2007/0029222 A1 2/2007 Shepardson  
 2007/0031635 A1 2/2007 Shepardson  
 2010/0096526 A1 4/2010 Richardson  
 2011/0114807 A1 5/2011 Richardson

OTHER PUBLICATIONS

Photograph of Hair Clip, (1 page).  
 "What is it with Boys Being Obsessed with Hair Clips?" printed from <http://sheenaspace.wordpress.com/2012/05/01/what-is-it-with-boys-being-obsessed-with-hair-clips/> published May 1, 2012 (2 pages).  
 "Club Pack of 24 Red and Gold Glass Candle Clip-On Christmas Ornaments 5.5", printed from <http://shop.christmascentral.com/items/item.aspx?itemid=10836187> available at least as early as Sep. 14, 2011 (2 pages).  
 "Classic Medium Claw Clips", printed from [www.goody.com/Products/Hair\\_Accessories/Classics\\_Medium\\_Claw\\_Clips](http://www.goody.com/Products/Hair_Accessories/Classics_Medium_Claw_Clips), (1 page).  
 "Holiday Hair", printed from [www.styleblueprint.com/health-and-beauty/holiday-hair/](http://www.styleblueprint.com/health-and-beauty/holiday-hair/) posted on Dec. 8, 2011 (7 pages).  
 GKI Bethlehem Lighting Reflections Novelty Christmas Tree Topper with Morphing LED and Mounting Arm, Bethlehem Star. GKI Bethlehem Lighting. Amazon.com, May 3, 2011 (oldest review date Jan. 7, 2009) [retrieved on Sep. 16, 2014]. Retrieved from the Internet: <<http://www.amazon.com/GKI-Bethlehem-Lighting-Reflections-Christmas/dp/B0014XUTMG>> (6 pages).  
 "Elf Logic 12" Moravian Star Christmas Tree Topper", printed from [www.amazon.com/Moravian-Christmas-Topper-Elf-Logic/dp/B0...s11&tag=randallheavy-20&linkId=d13c856e3d4b9dc3c233915a8066bb88](http://www.amazon.com/Moravian-Christmas-Topper-Elf-Logic/dp/B0...s11&tag=randallheavy-20&linkId=d13c856e3d4b9dc3c233915a8066bb88), publicly available as early as Oct. 20, 2016 (8 pages).  
 "LinziClip Claw Hairclips Review", printed from [www.cosmetopiadigest.com/2014/10/linzi-clip-butterfly-hair-holders-review-founders-feature.html](http://www.cosmetopiadigest.com/2014/10/linzi-clip-butterfly-hair-holders-review-founders-feature.html), posted on Oct. 30, 2014 (20 pages).

\* cited by examiner

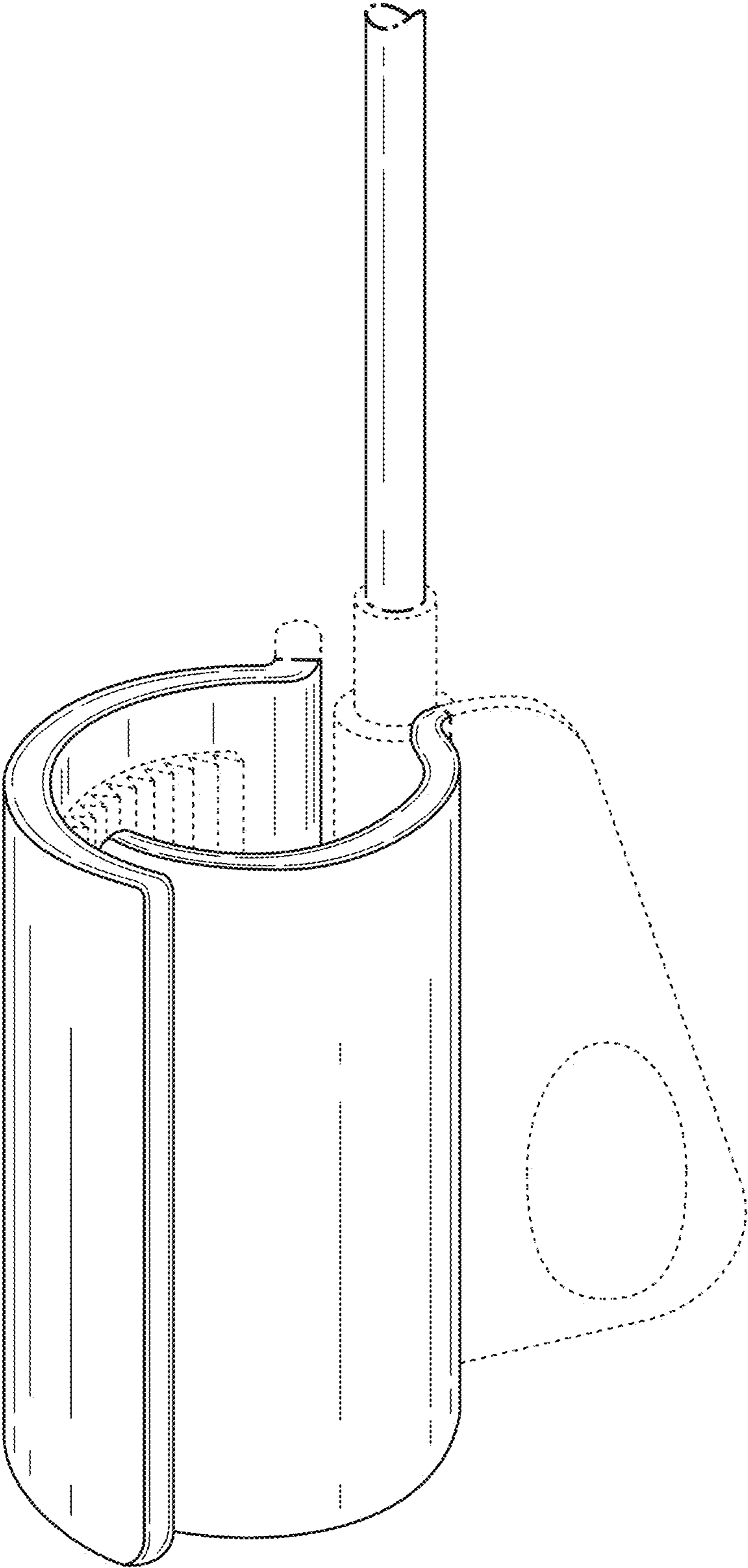

FIG. 1

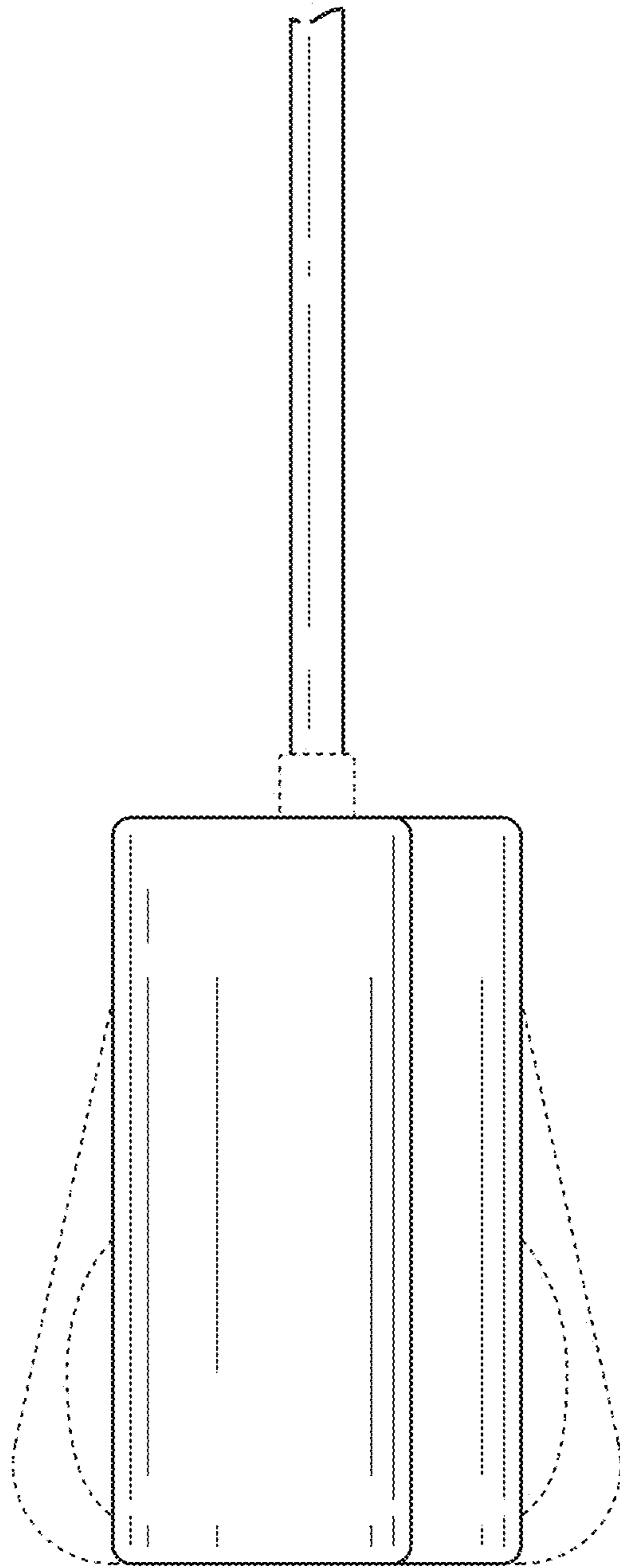
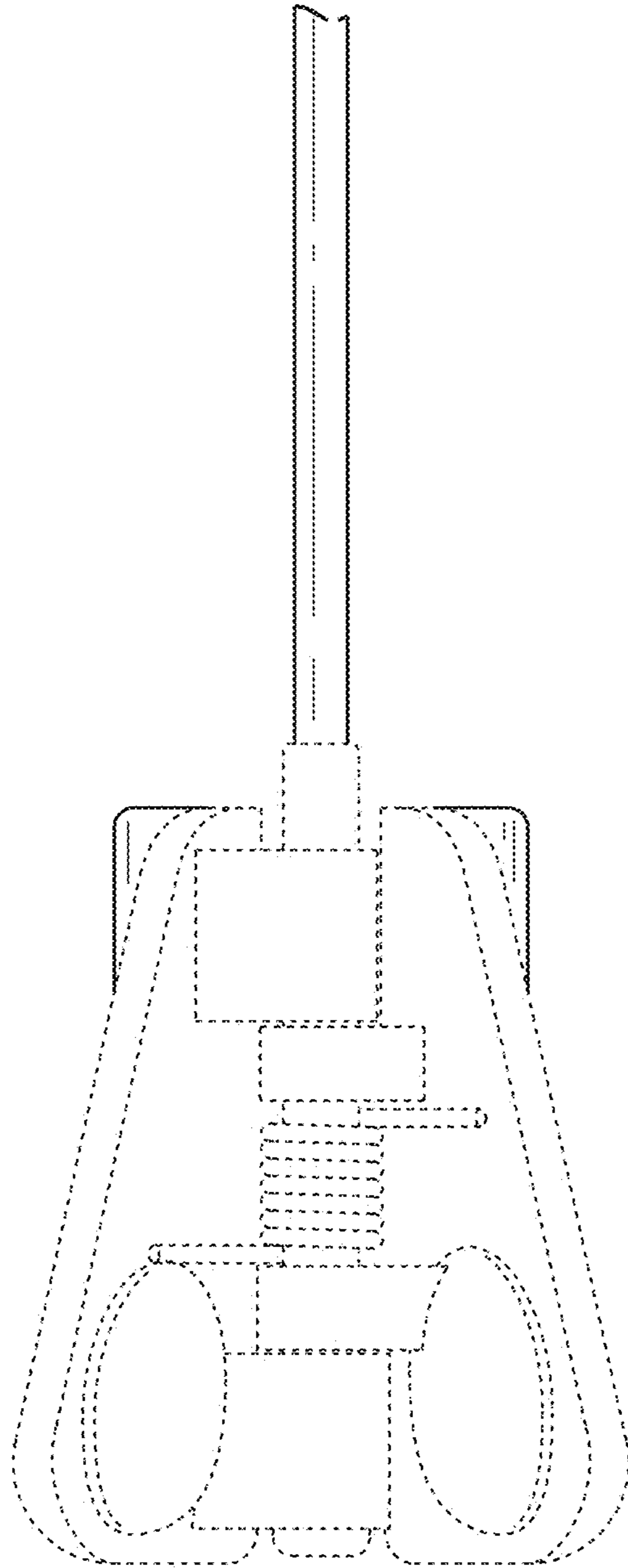

FIG. 2





**FIG. 3**

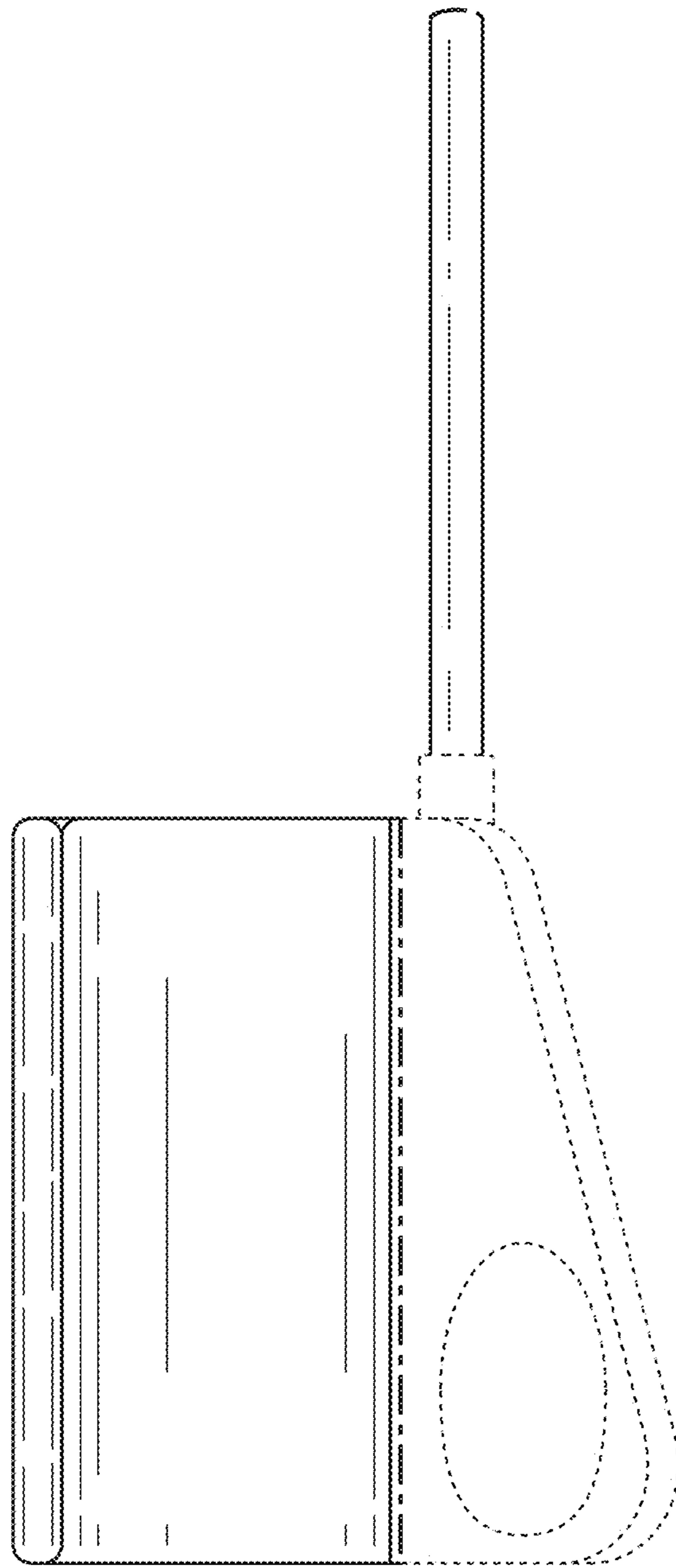

FIG. 4

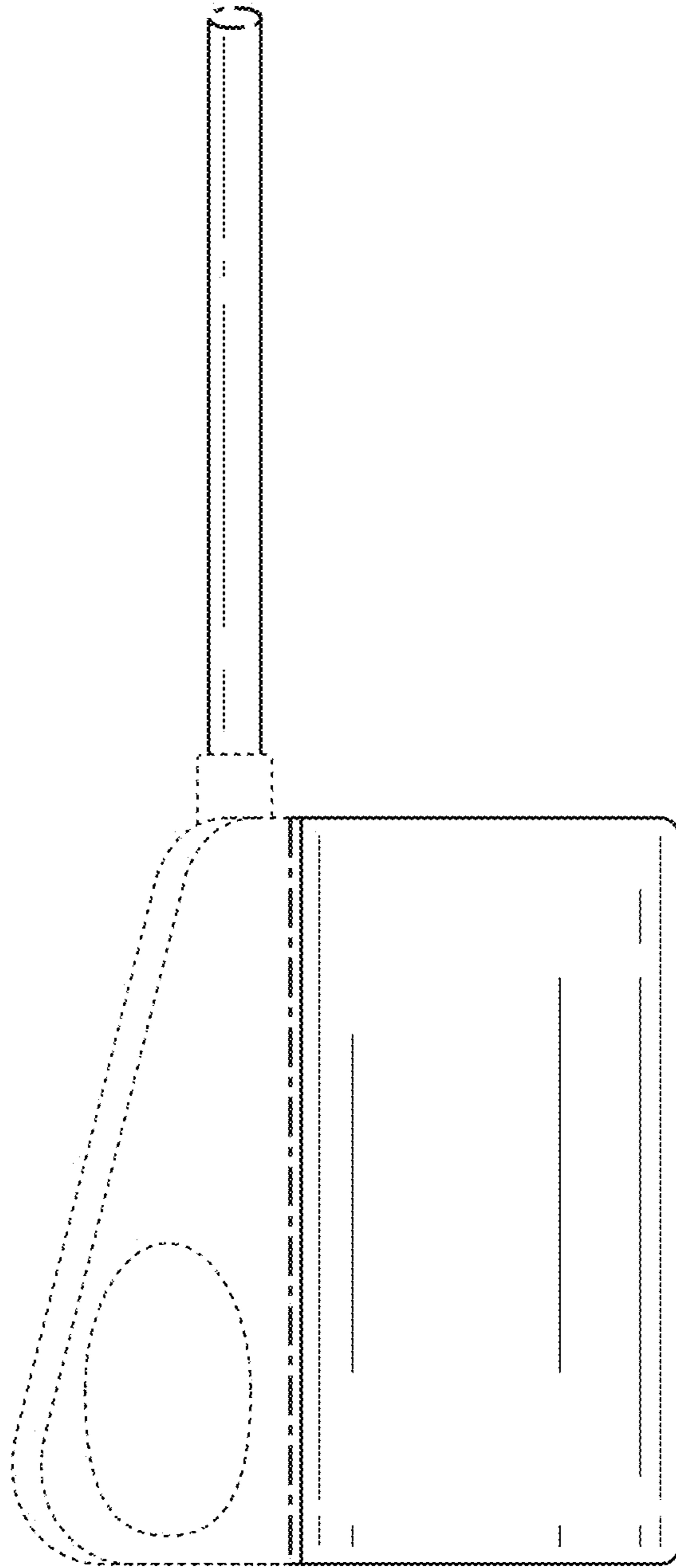

FIG. 5

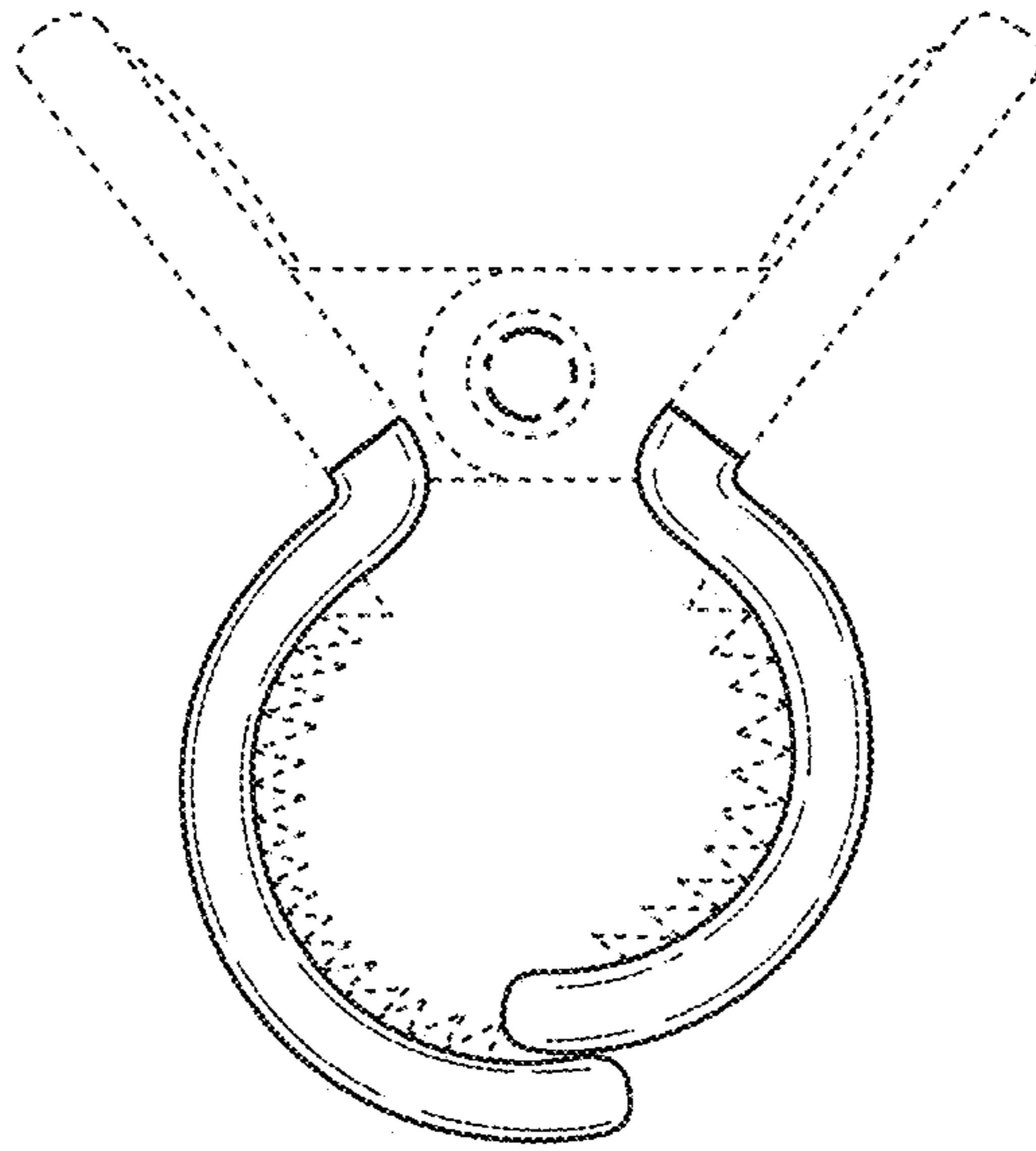

FIG. 6

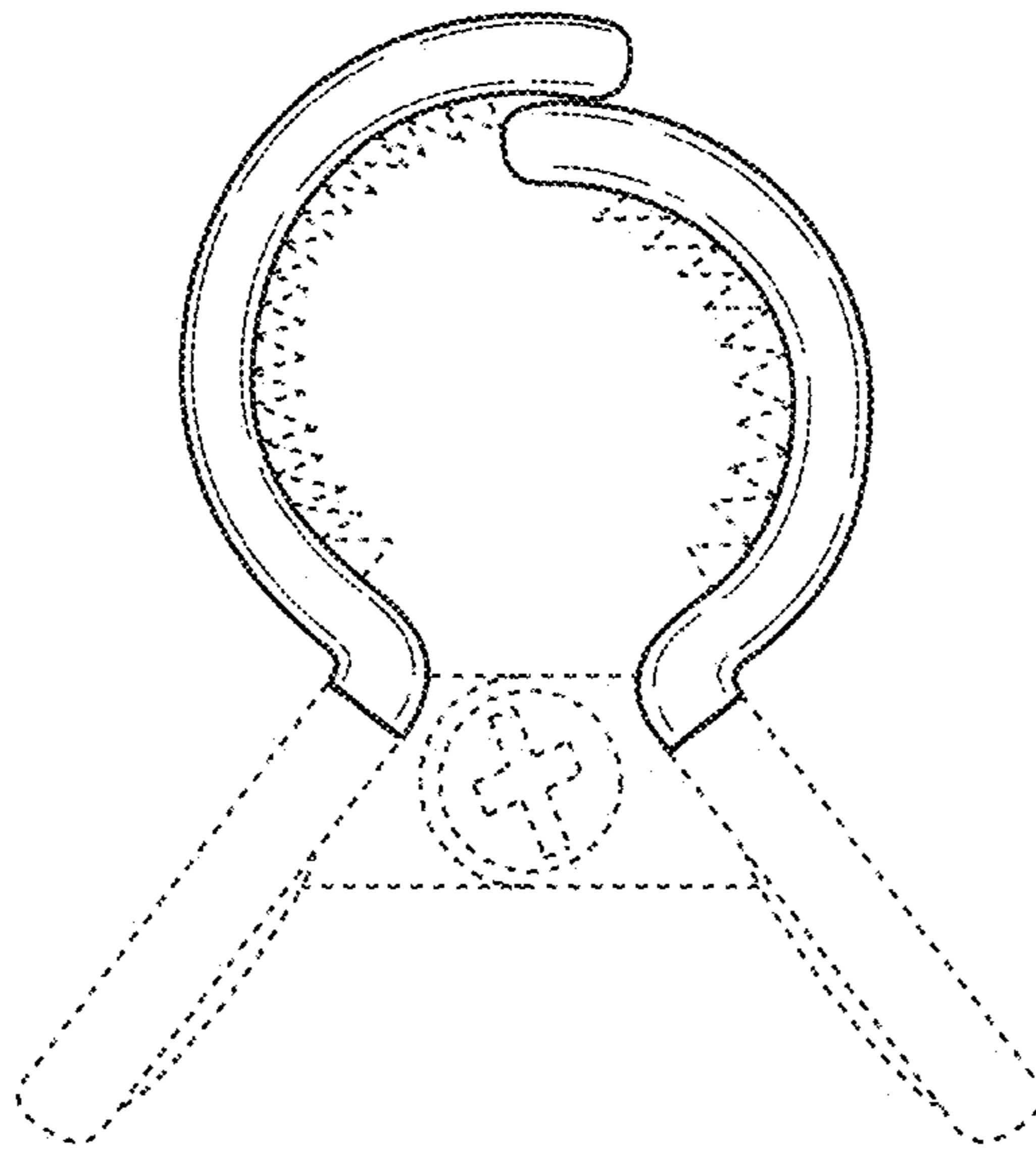

FIG. 7



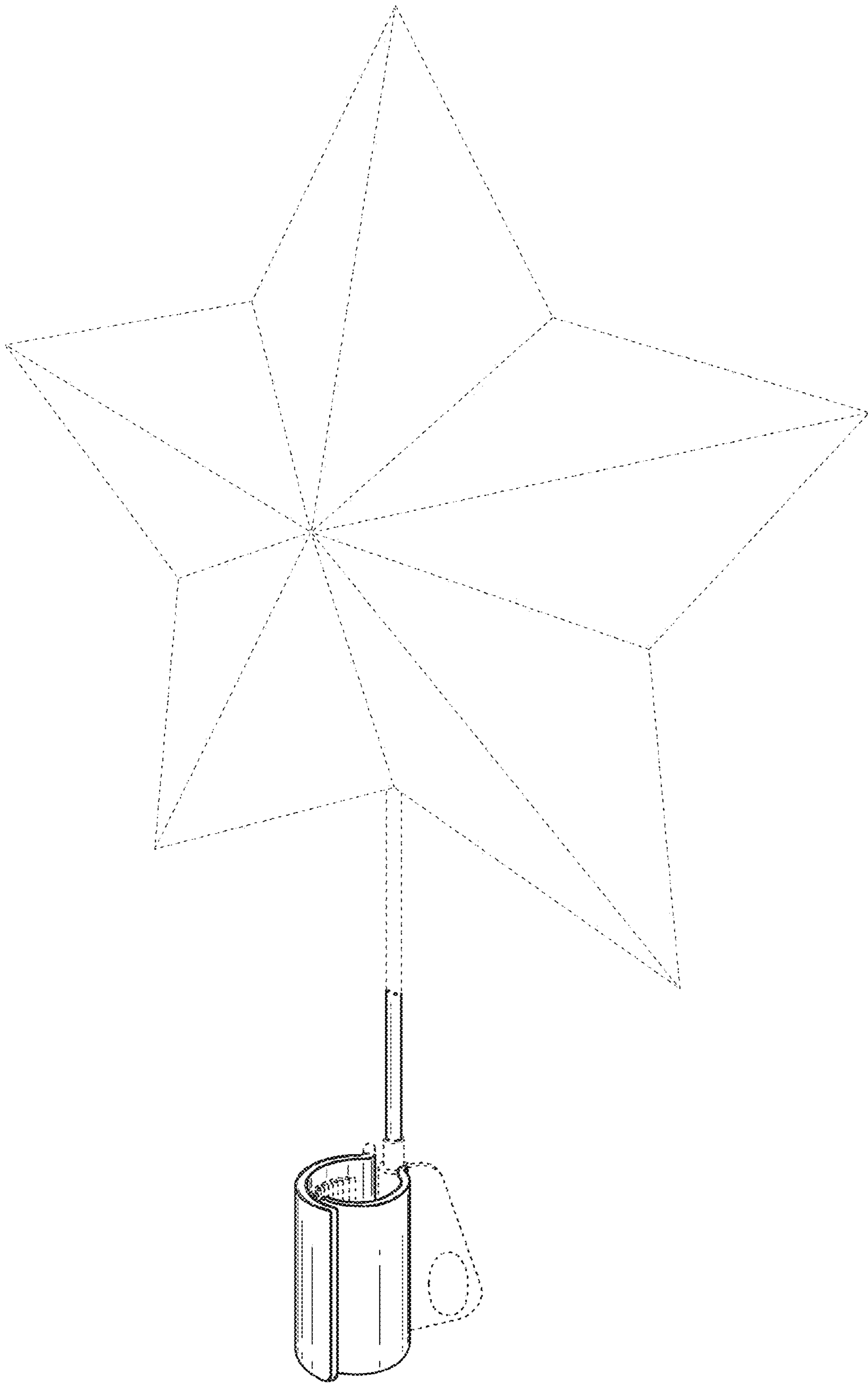

FIG. 8

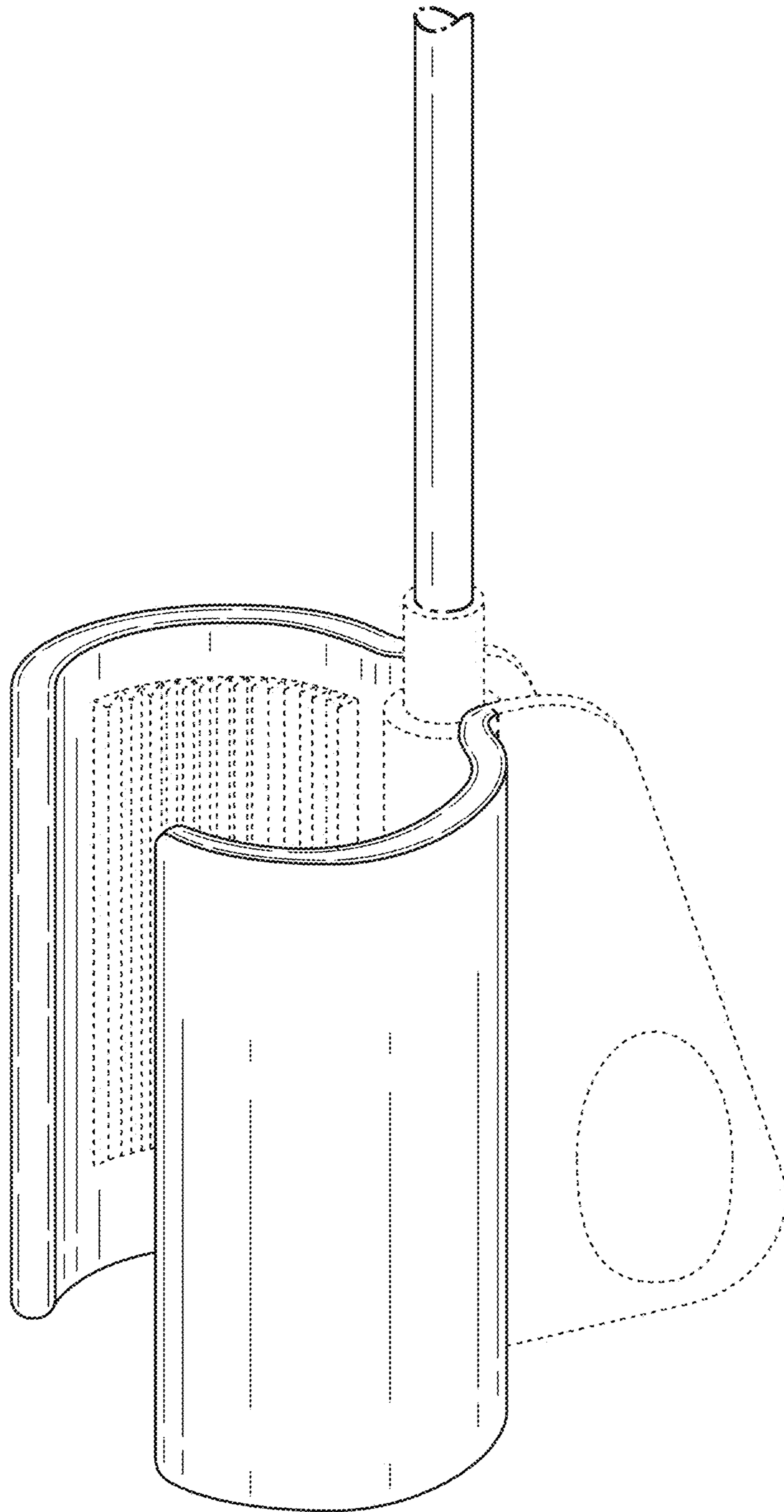

FIG. 9

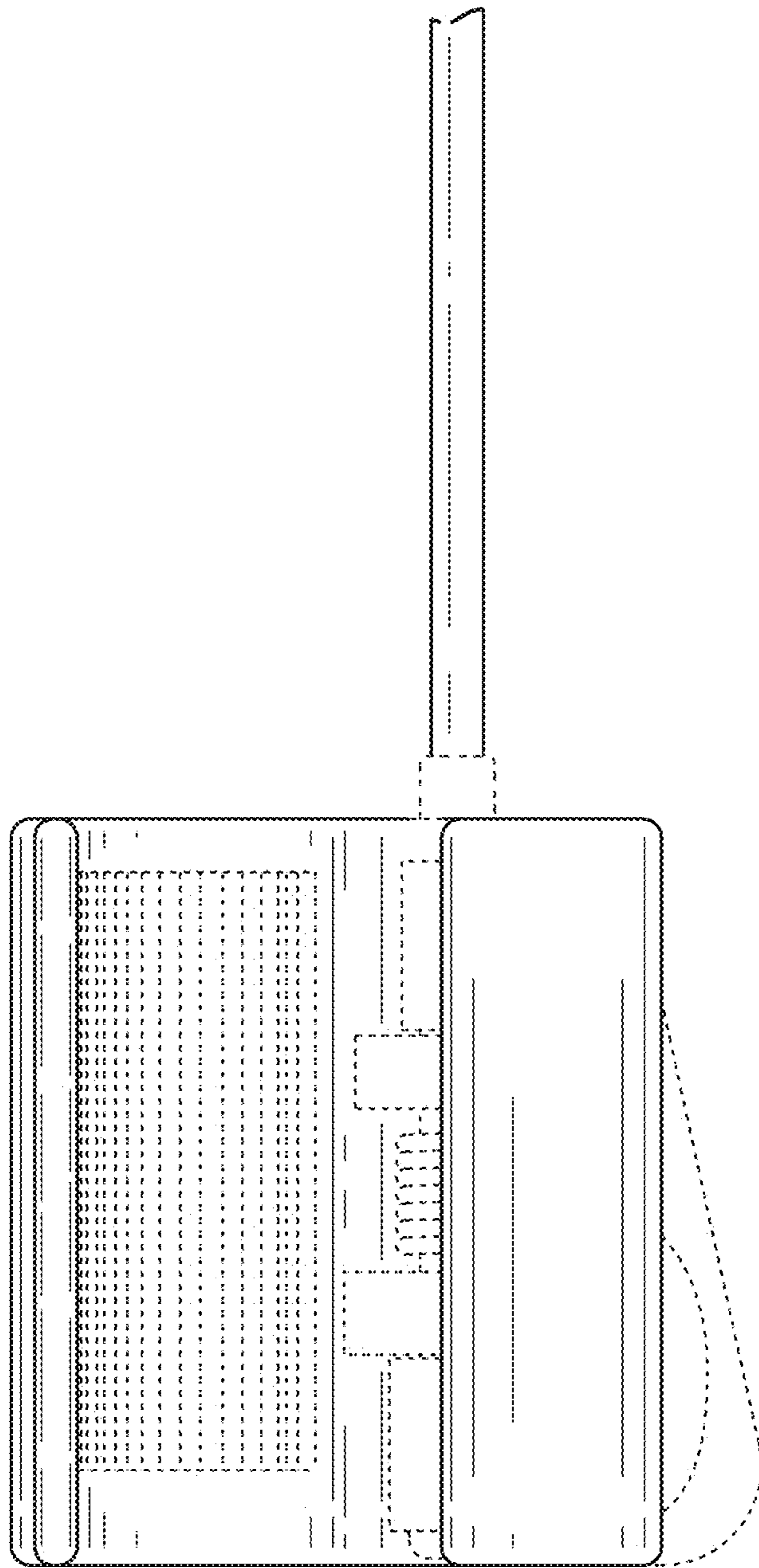

FIG. 10

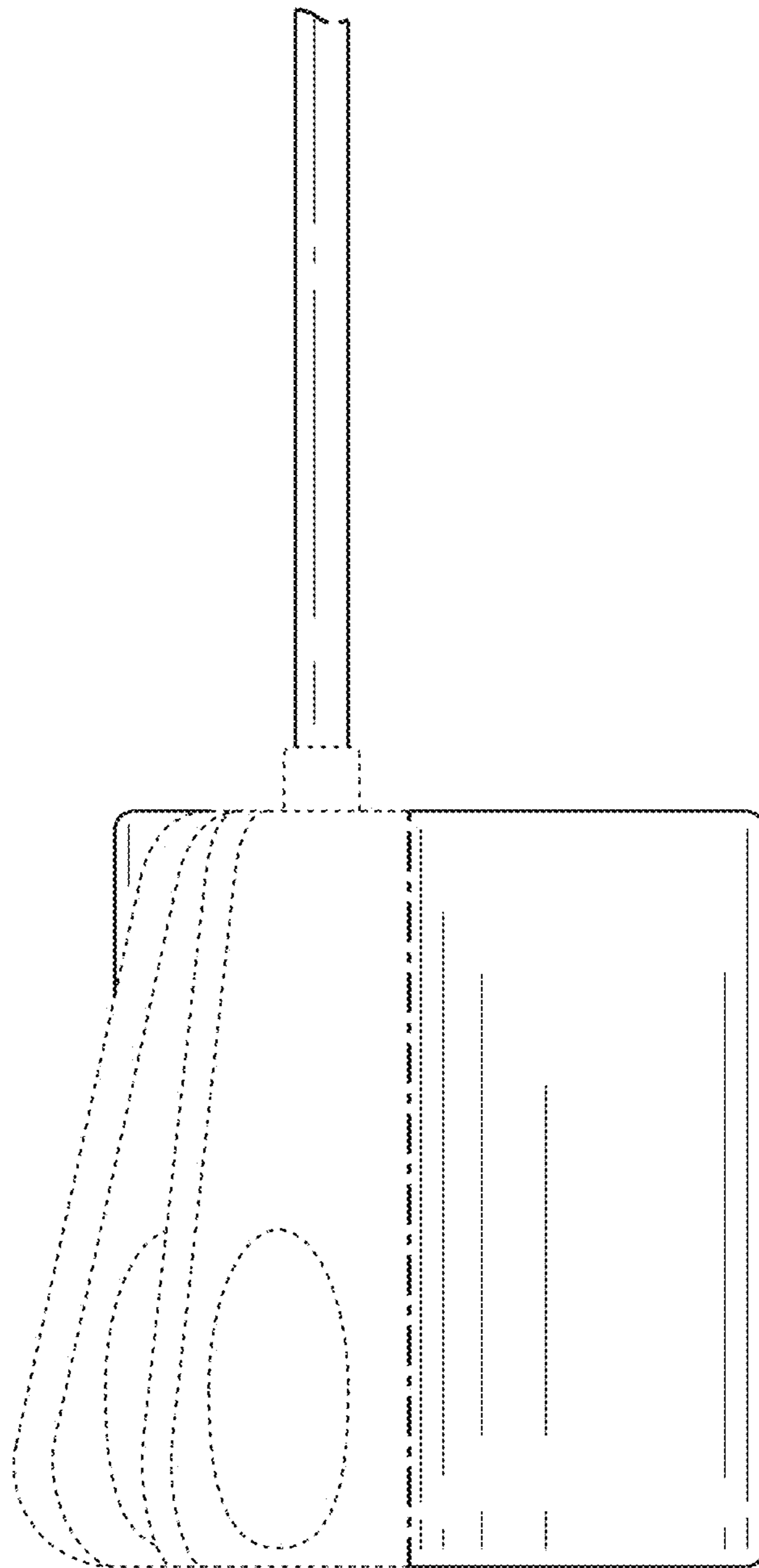
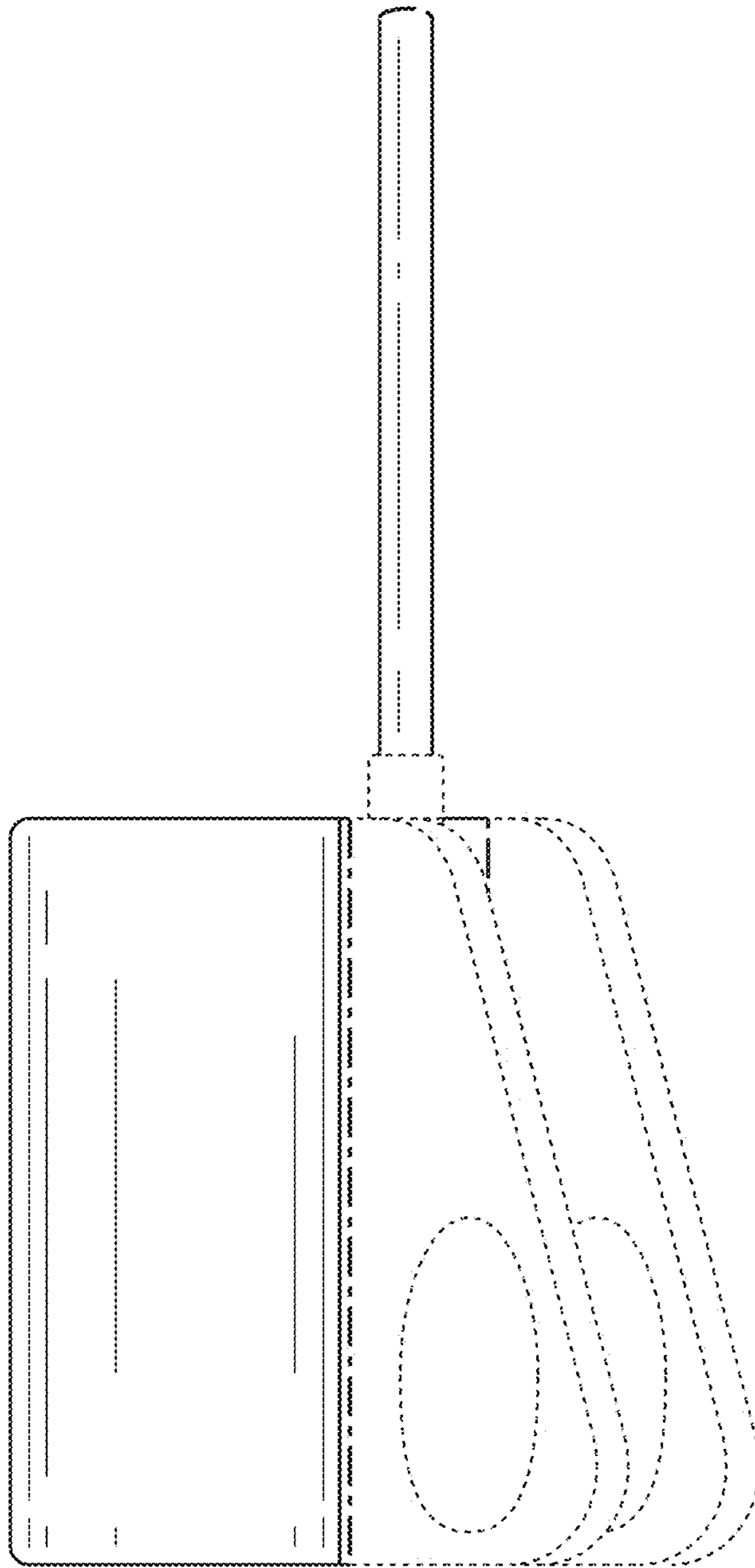
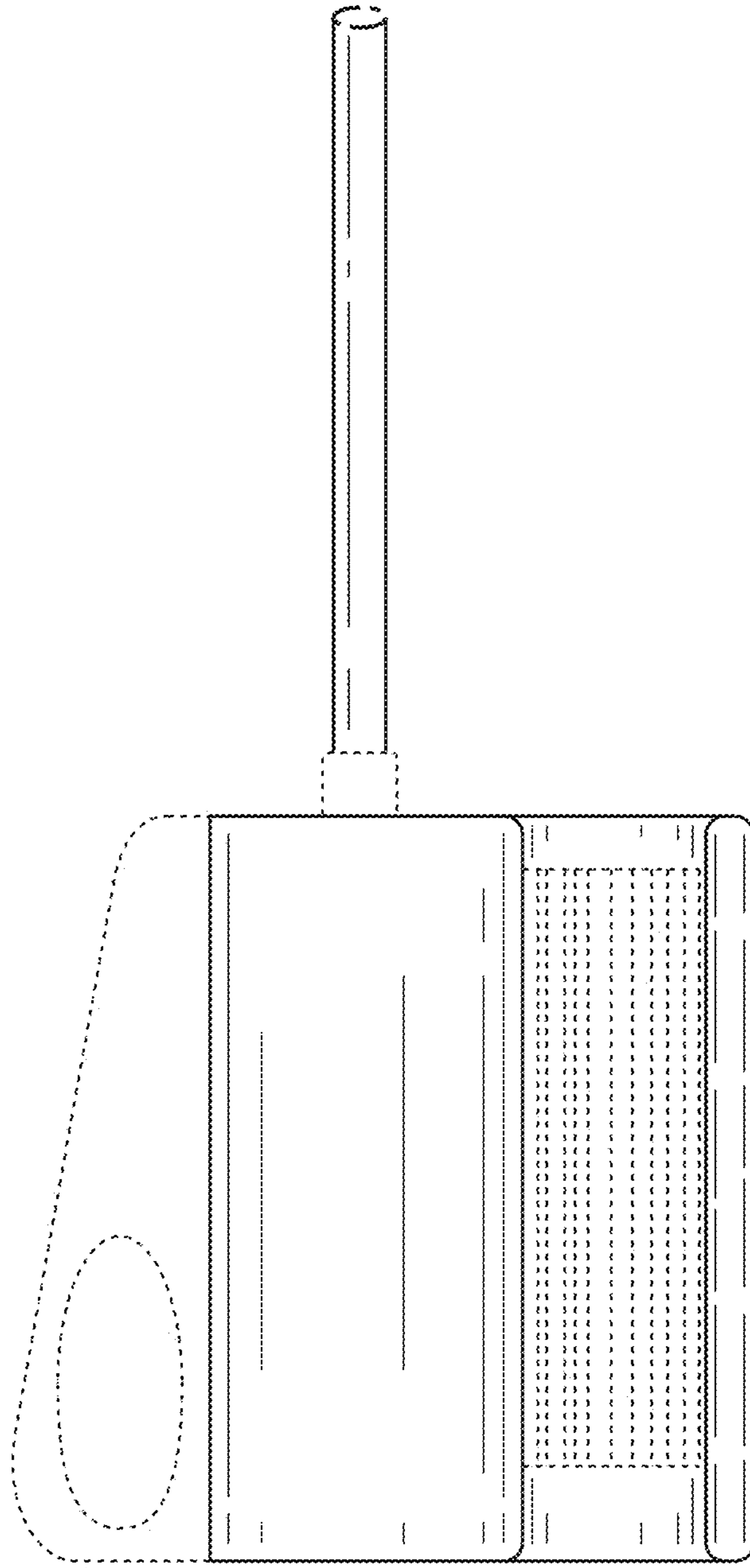

FIG. 11



**FIG. 12**





**FIG. 13**

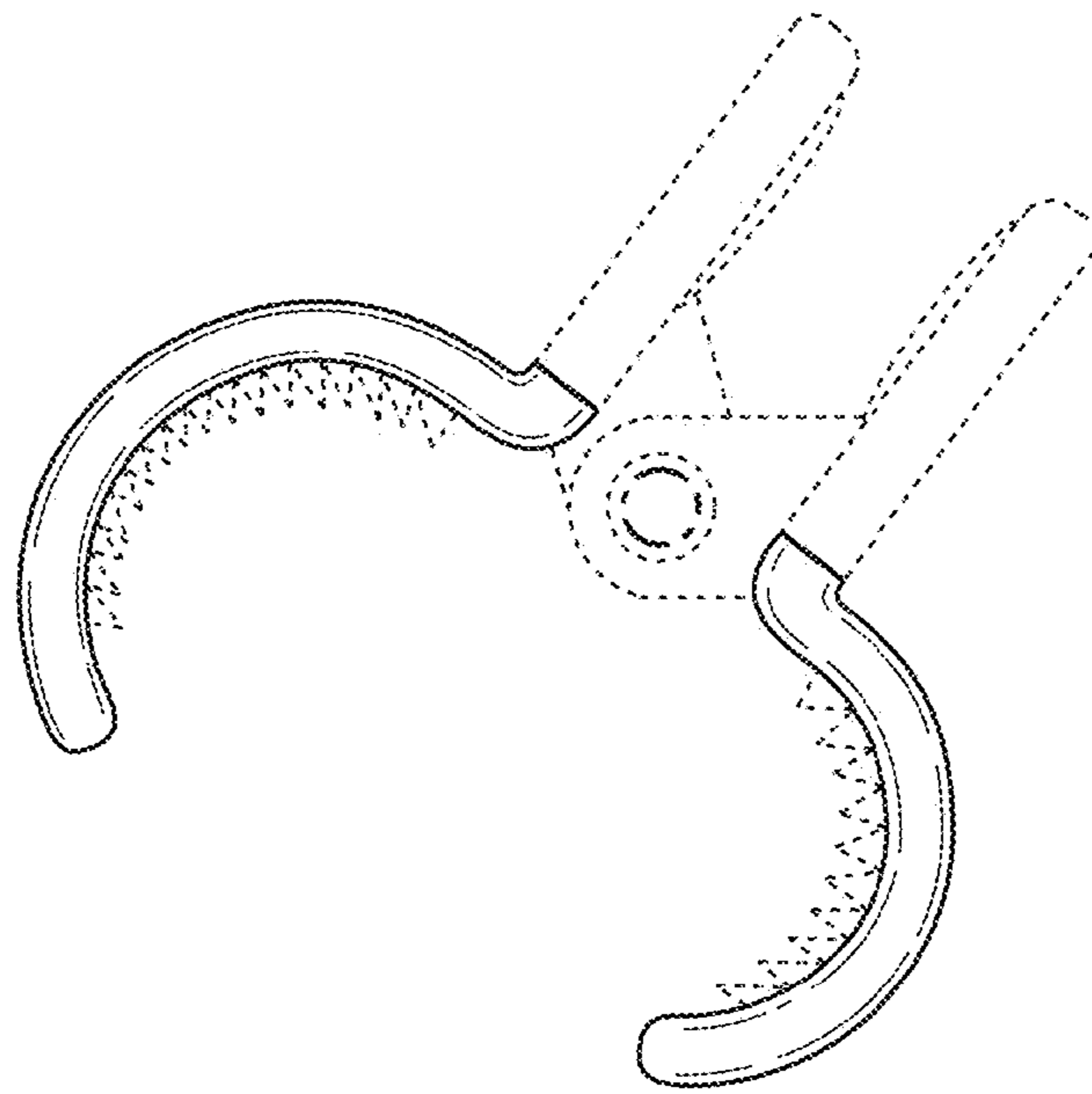

FIG. 14

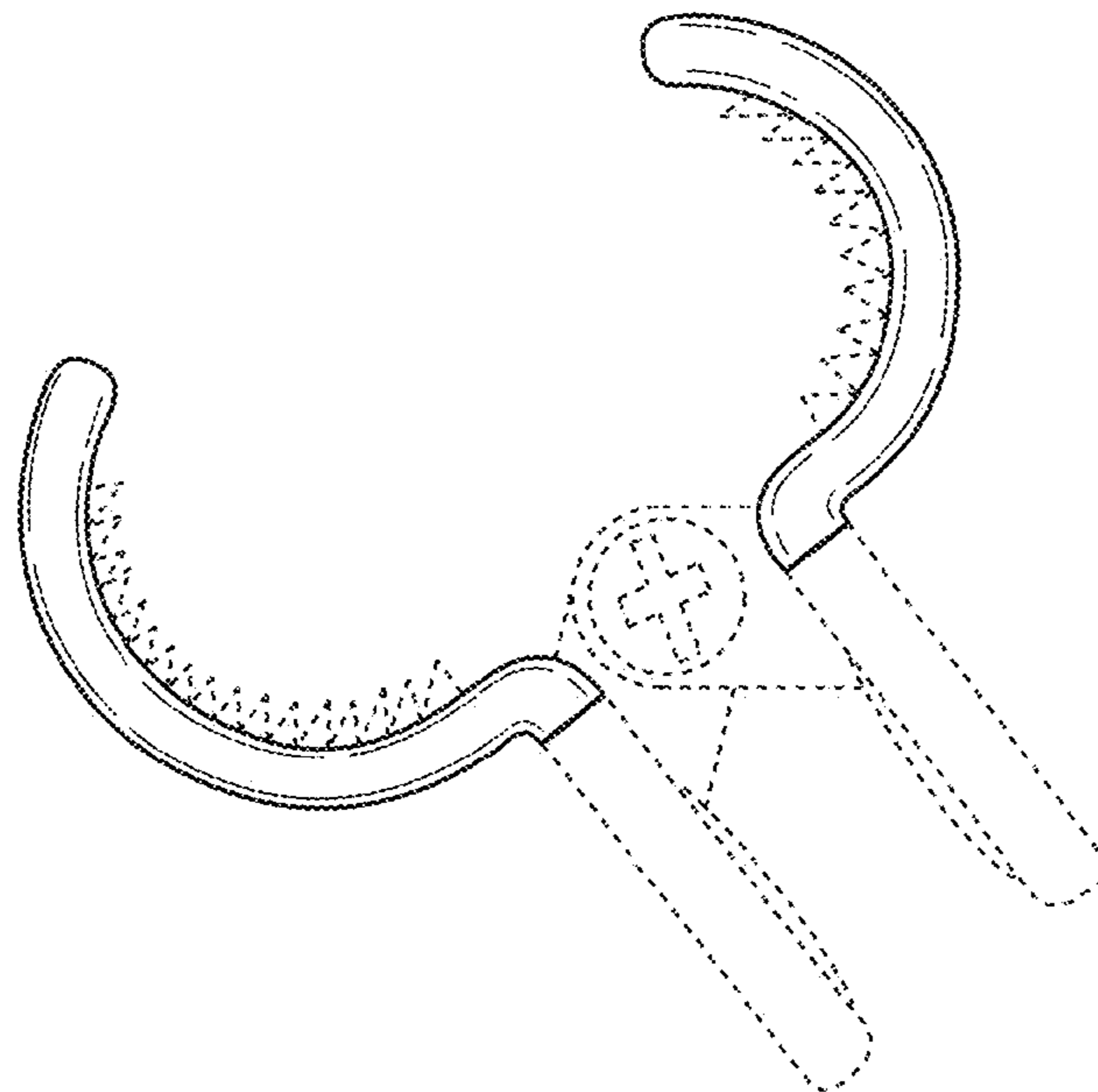

FIG. 15