



US00D889764S

(12) **United States Design Patent** (10) **Patent No.:** **US D889,764 S**
Terry et al. (45) **Date of Patent:** **** Jul. 7, 2020**

(54) **WHEEL LIFTING APPARATUS**
(71) Applicants: **Billy Terry**, Rensselaer, NY (US);
Norman Fiato, Rensselaer, NY (US)
(72) Inventors: **Billy Terry**, Rensselaer, NY (US);
Norman Fiato, Rensselaer, NY (US)
(**) Term: **15 Years**
(21) Appl. No.: **29/651,367**
(22) Filed: **Jun. 14, 2018**
(51) **LOC (12) Cl.** **12-05**
(52) **U.S. Cl.**
USPC **D34/28**
(58) **Field of Classification Search**
USPC D34/28, 31
CPC B60B 29/002; B66F 5/02; B66F 7/0625;
B66F 7/0641
See application file for complete search history.

5,732,960 A * 3/1998 Elam B60B 29/002
254/113
7,097,406 B1 * 8/2006 Gang B60B 29/002
254/105
D532,575 S * 11/2006 Oberg D34/28
7,232,138 B2 * 6/2007 Shubert B60P 3/125
280/47.34
8,651,501 B1 * 2/2014 Davis B62B 5/0086
254/133 R
9,102,344 B2 * 8/2015 Heinz B62B 3/02
9,302,543 B1 * 4/2016 Pierce B60B 30/10
D817,586 S * 5/2018 Romaoa D34/28
D824,132 S * 7/2018 Shao D34/31
D827,241 S * 8/2018 Kritzer D34/28
D868,413 S * 11/2019 Stannow D34/28
2003/0091416 A1 * 5/2003 Tortellier B60B 29/002
414/426
2007/0182115 A1 * 8/2007 Groomes B60B 29/002
280/79.4

(Continued)

Primary Examiner — Cynthia Ramirez
(74) *Attorney, Agent, or Firm* — Paul R. Martin

(56) **References Cited**
U.S. PATENT DOCUMENTS

4,692,082 A * 9/1987 Smith B66F 5/02
414/429
4,854,803 A * 8/1989 Coccaro B60B 29/002
414/429
4,925,357 A * 5/1990 Cisternino B62B 5/0083
254/8 R
5,112,070 A * 5/1992 Hahn B60B 29/002
280/79.4
5,184,930 A * 2/1993 Kuhn B66F 5/04
187/208
D335,739 S * 5/1993 Holman D34/31
5,505,578 A * 4/1996 Fuller B60B 29/002
212/901
D370,109 S * 5/1996 Hodges D34/23
5,702,226 A * 12/1997 Pickle B60B 29/002
280/79.4
5,716,061 A * 2/1998 Sloan B62B 1/06
254/131

(57) **CLAIM**

The ornamental design for wheel lifting apparatus, as shown and described.

DESCRIPTION

FIG. 1 is a perspective view of the wheel lifting apparatus of our new design, shown in condition for use.
FIG. 2 is a bottom plan view thereof.
FIG. 3 is a top plan view thereof.
FIG. 4 is a front elevational view thereof.
FIG. 5 is a back elevational view thereof.
FIG. 6 is a left side elevational view thereof; and,
FIG. 7 is a right side elevational view thereof.
The broken lines in FIG. 1 showing an ATV vehicle and lifting equipment are for environmental purposes only, and form no part of the claimed design.

1 Claim, 5 Drawing Sheets

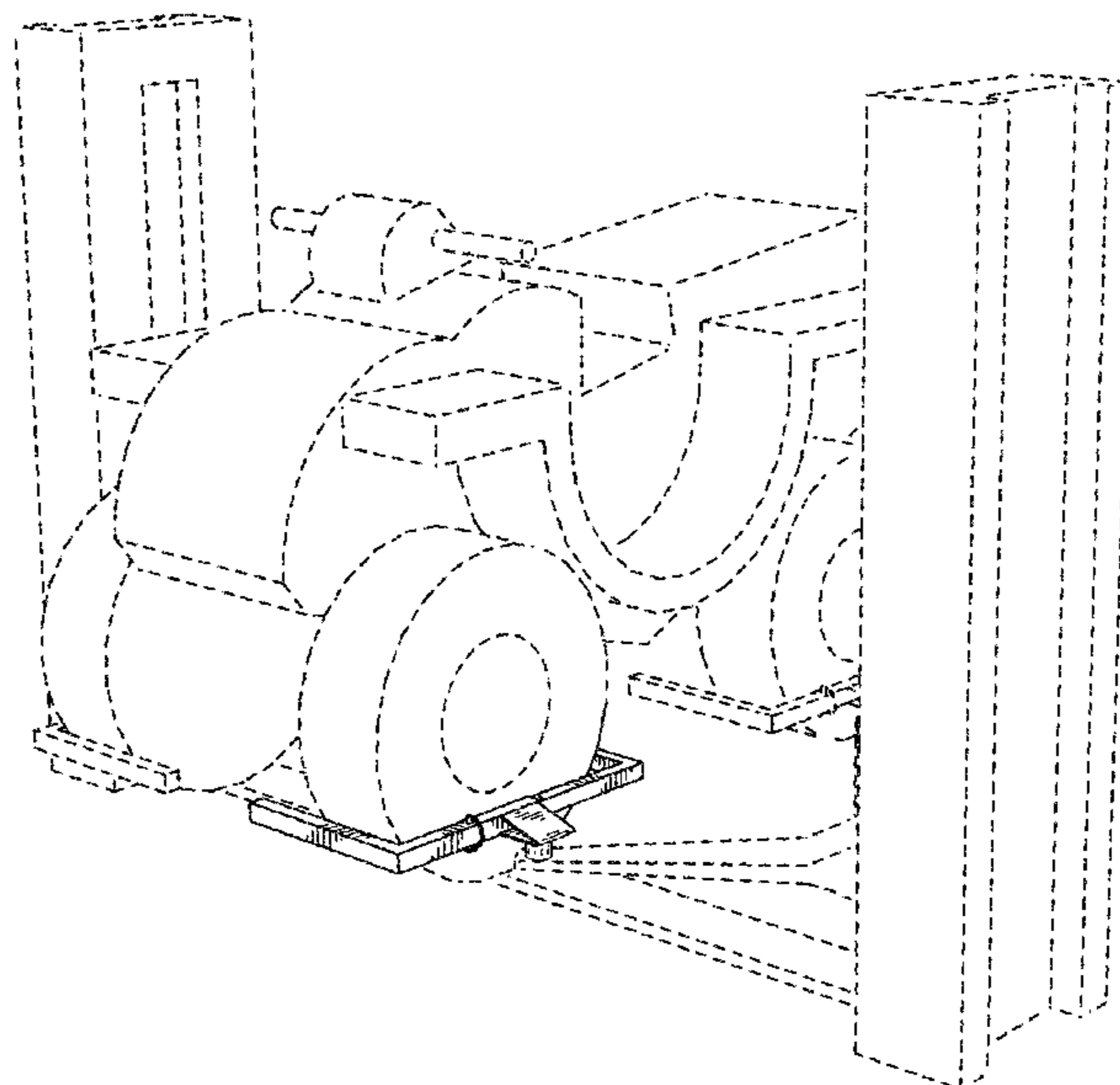

(56)

References Cited

U.S. PATENT DOCUMENTS

2008/0101898 A1* 5/2008 Hernandez B60B 29/002
414/426
2008/0273954 A1* 11/2008 Kroeg B60B 29/002
414/428
2017/0217743 A1* 8/2017 Mathieson B66F 5/025
2017/0232793 A1* 8/2017 Ang B60B 30/02
414/426
2019/0248634 A1* 8/2019 Stapensea B66F 17/006

* cited by examiner

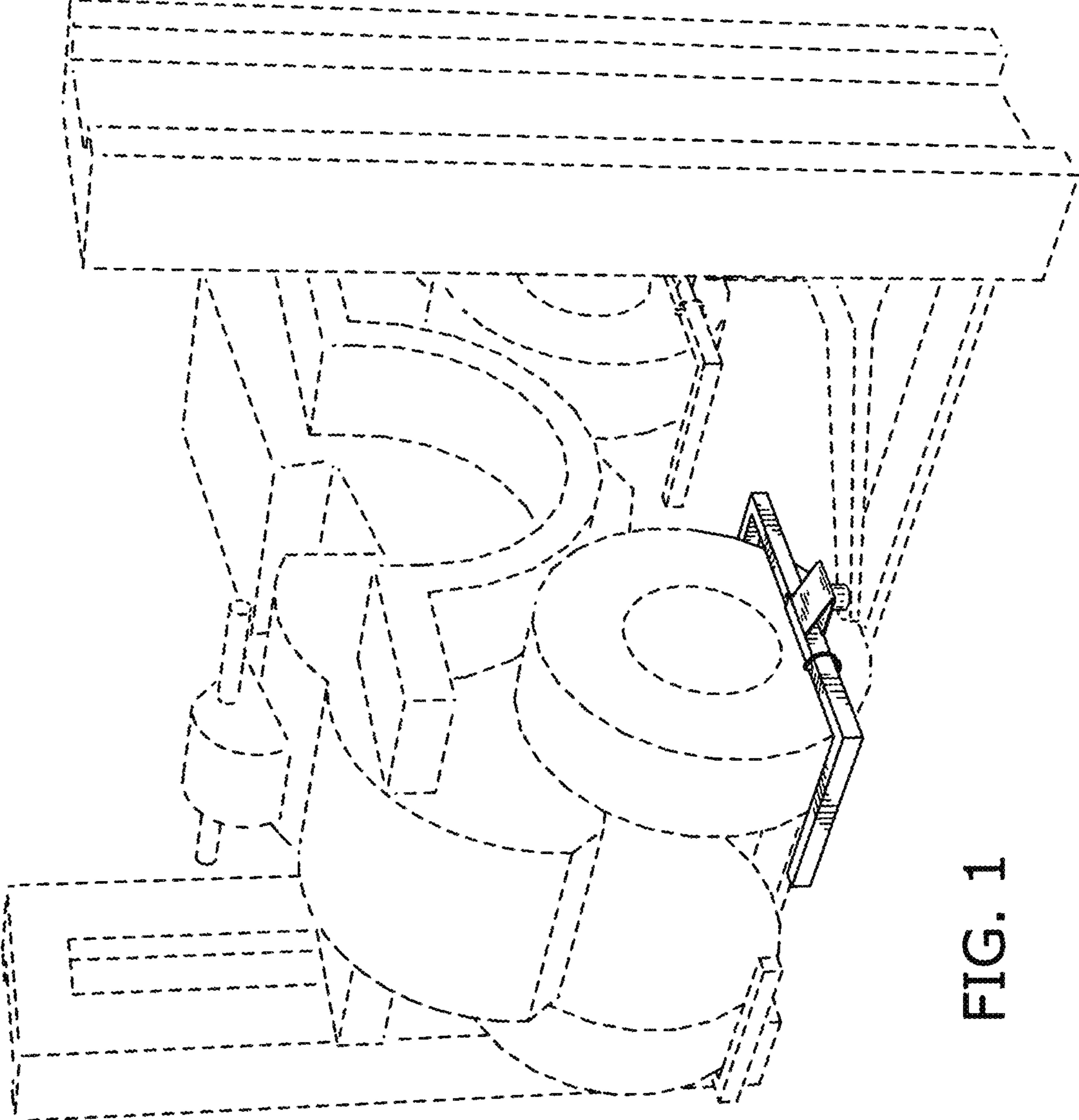

FIG. 1

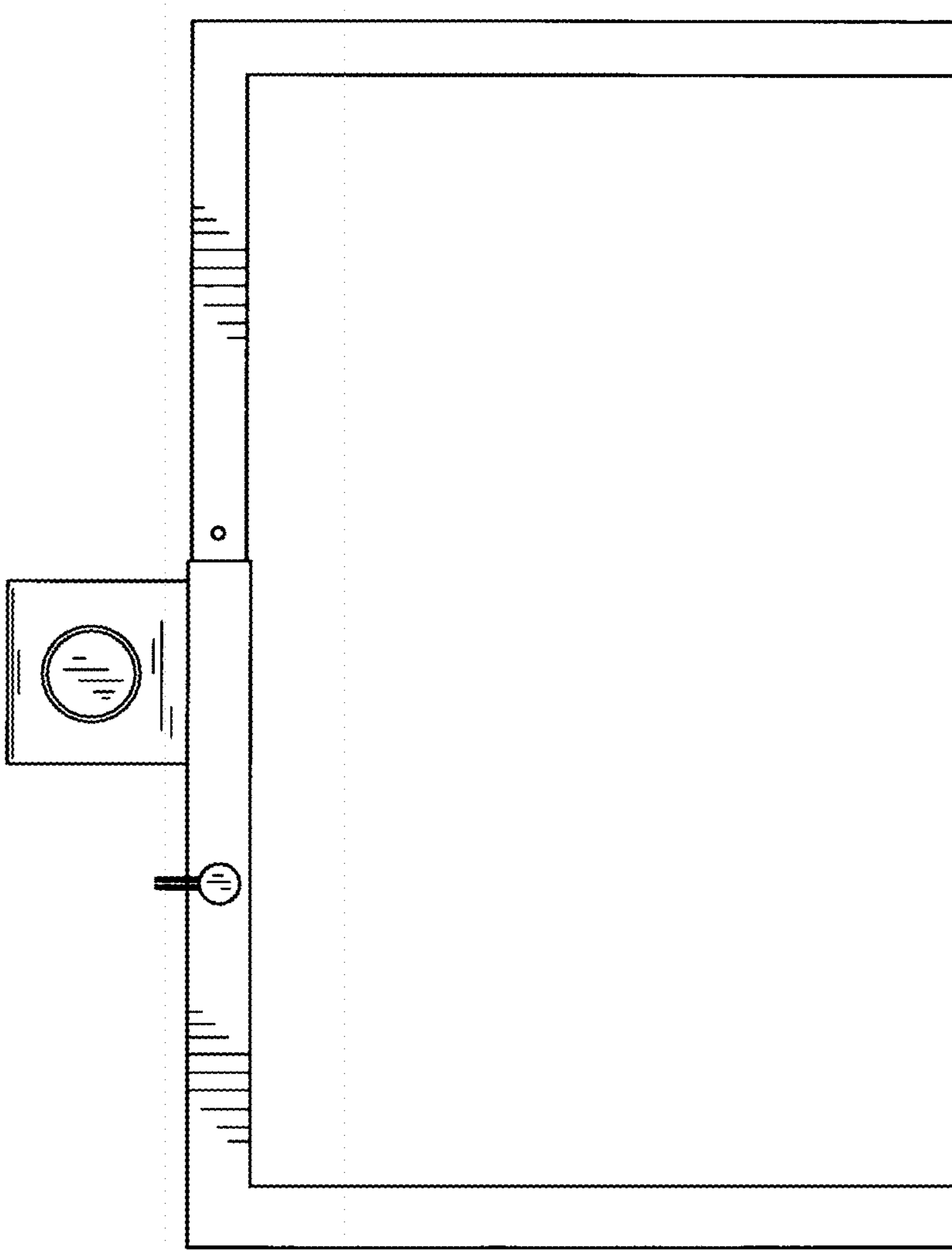

FIG. 2

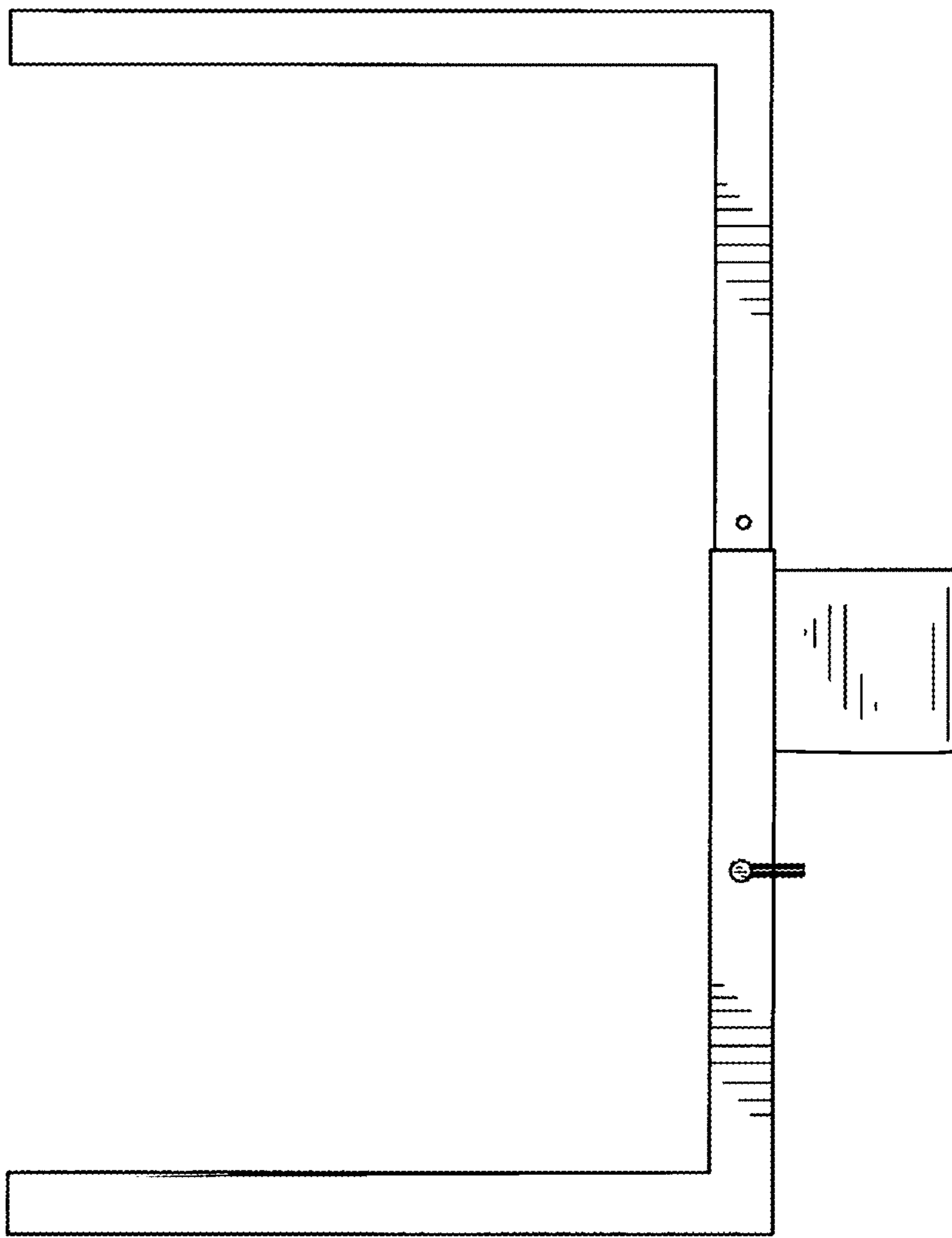

FIG. 3

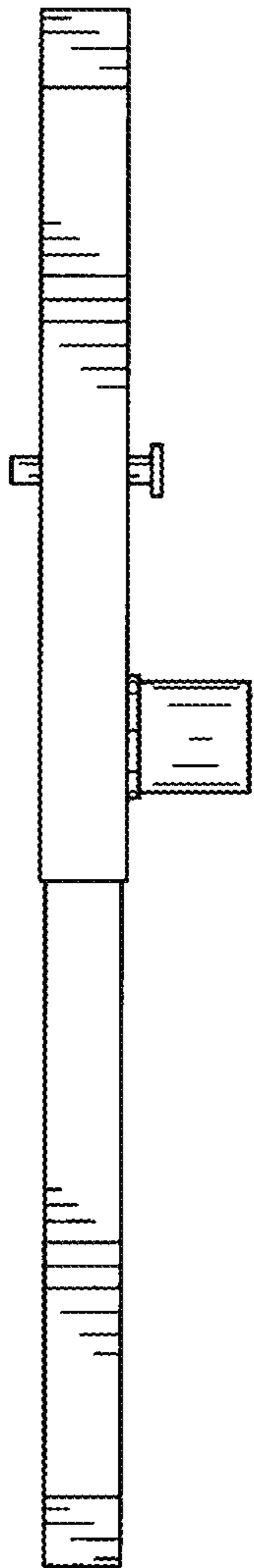

FIG. 4

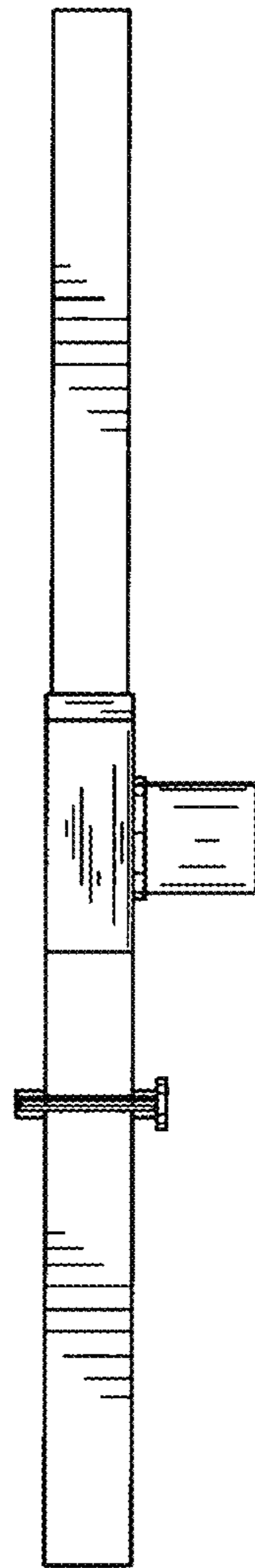

FIG. 5

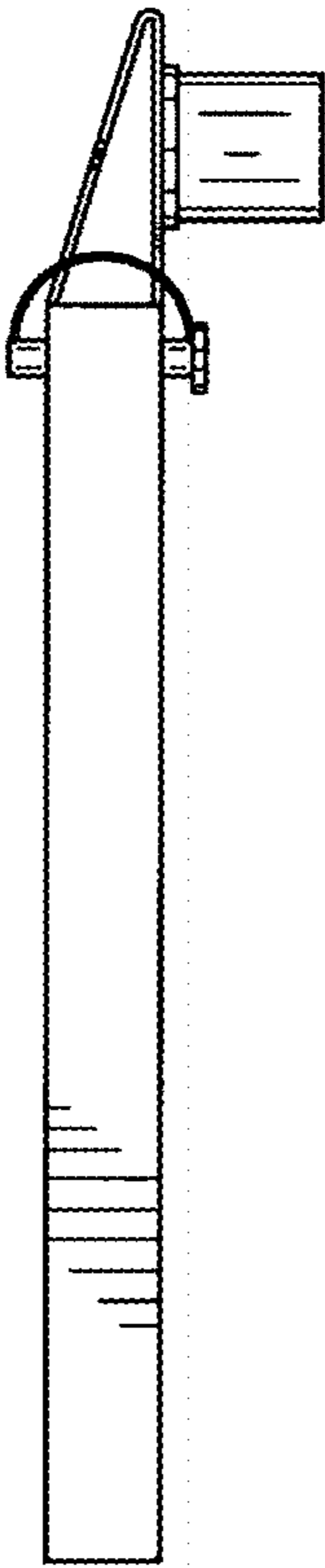

FIG. 6

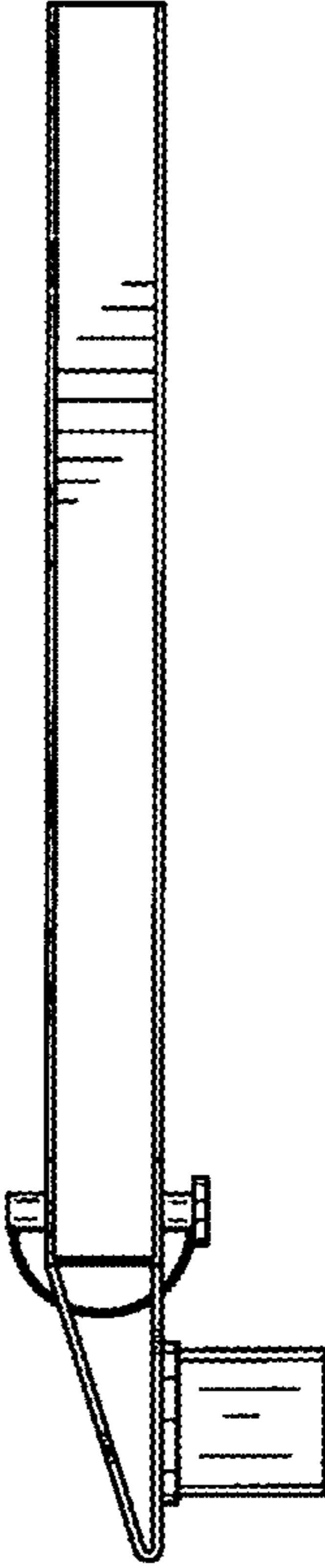

FIG. 7