



US00D889590S

(12) **United States Design Patent**  
**Fan**

(10) **Patent No.:** **US D889,590 S**  
(45) **Date of Patent:** **\*\* Jul. 7, 2020**

- (54) **STUN GUN**
- (71) Applicant: **Cutting Edge Products, Inc.**,  
Winterville, NC (US)
- (72) Inventor: **ZhiGang Fan**, Jingjiang (CN)
- (73) Assignee: **Cutting Edge Products, Inc.**,  
Winterville, NC (US)
- (\*\*) Term: **15 Years**
- (21) Appl. No.: **29/692,840**
- (22) Filed: **May 29, 2019**
- (51) **LOC (12) Cl.** ..... **22-02**
- (52) **U.S. Cl.**  
USPC ..... **D22/117; D3/215**
- (58) **Field of Classification Search**  
USPC ..... D22/117-118; 222/153.03, 153.11, 162,  
222/172, 175; 89/1.11; 206/38.1;  
361/232  
CPC ..... B65D 83/68; B65D 83/384; F41H 9/10;  
G08B 15/004; G08B 21/0297; H05B  
3/03; H05B 3/44  
See application file for complete search history.

D750,729 S *	3/2016	Sheikh	.....	D22/117
D806,824 S *	1/2018	Fan	.....	D22/117
D816,181 S *	4/2018	Chen	.....	D22/117
D826,364 S *	8/2018	Nawaz	.....	D22/117
2010/0296222 A1 *	11/2010	Nawaz	.....	F41B 15/04 361/232

**OTHER PUBLICATIONS**

Square Off 26,000,000 Keychain Stun Gun—White, CuttingEdgeProducts.com (Year: 2020).\*

\* cited by examiner

*Primary Examiner* — Catherine R Oliver-Garcia  
(74) *Attorney, Agent, or Firm* — Mitchell Law PLLC;  
Matthew W. Mitchell

(57) **CLAIM**

The ornamental design for a stun gun, as shown.

**DESCRIPTION**

FIG. 1 is a front isometric view of the stun gun of the present invention;  
FIG. 2 is a top plan view thereof;  
FIG. 3 is a bottom plan view thereof;  
FIG. 4 is a front view thereof;  
FIG. 5 is a rear view thereof;  
FIG. 6 is a left-side view thereof; and,  
FIG. 7 is a right-side isometric view thereof.

**1 Claim, 7 Drawing Sheets**

- (56) **References Cited**  
**U.S. PATENT DOCUMENTS**  
5,429,301 A \* 7/1995 Franks ..... B65D 83/384  
222/402.11  
D747,522 S \* 1/2016 Sheikh ..... D22/117

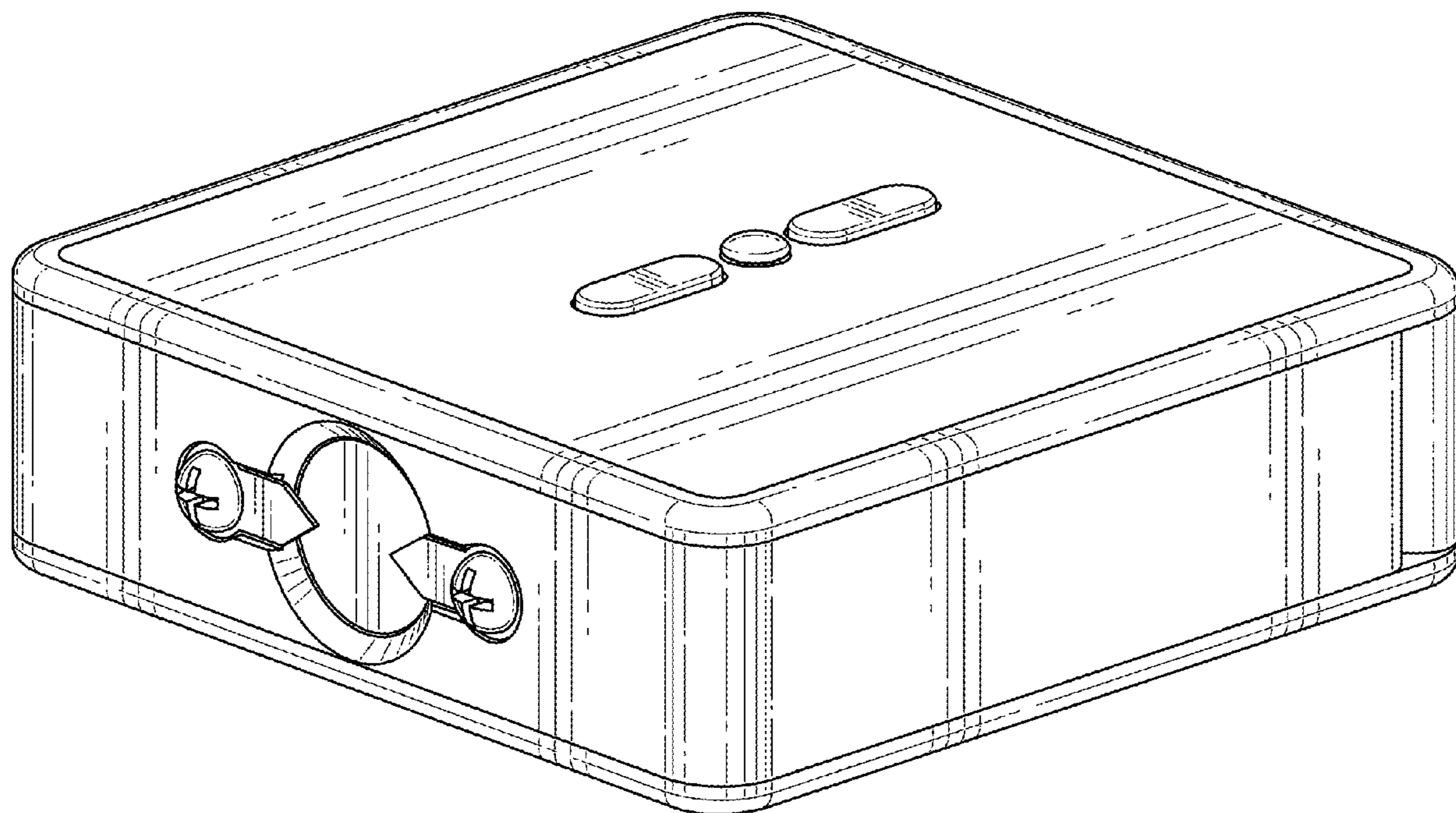

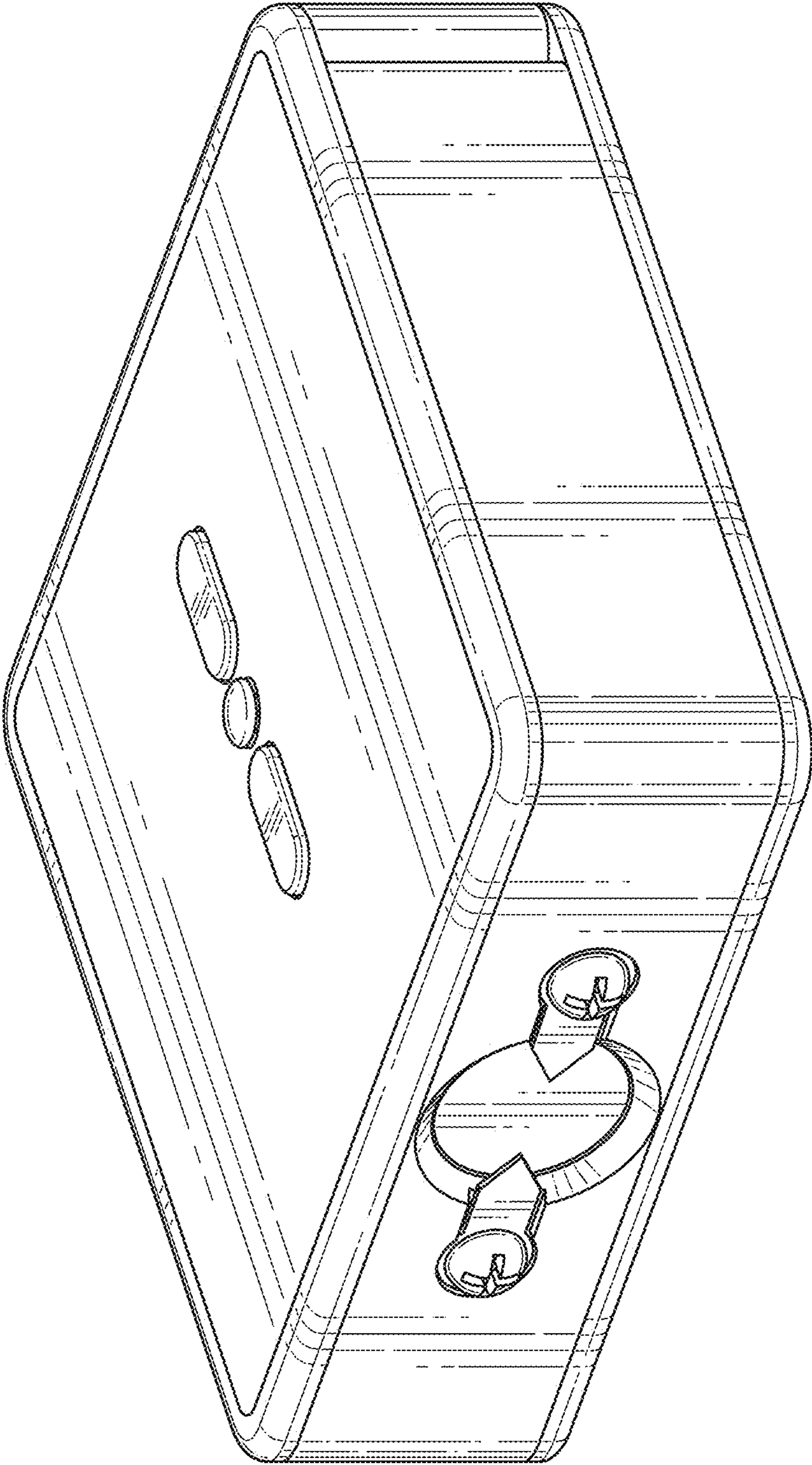

FIG. 1

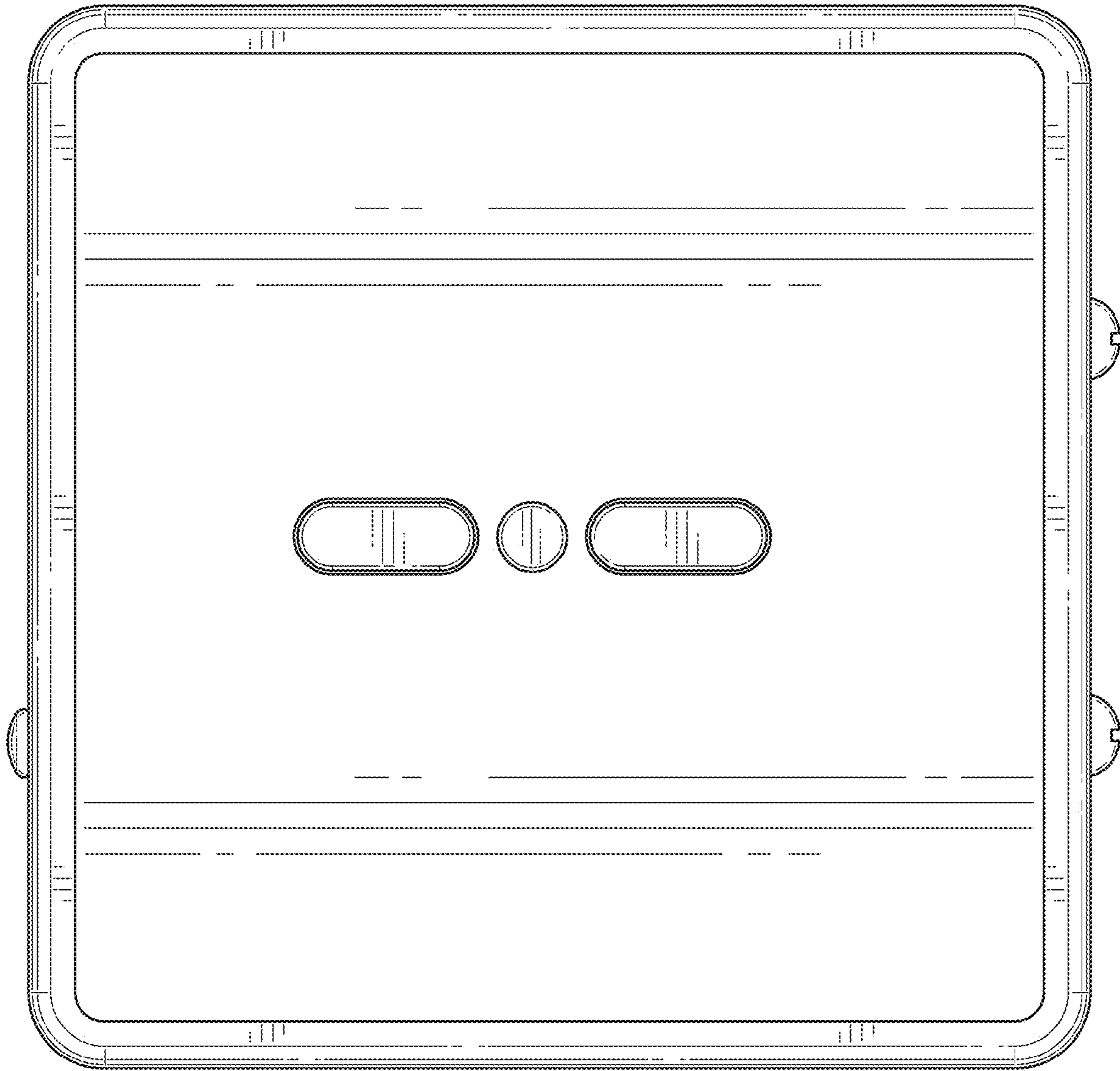

FIG. 2



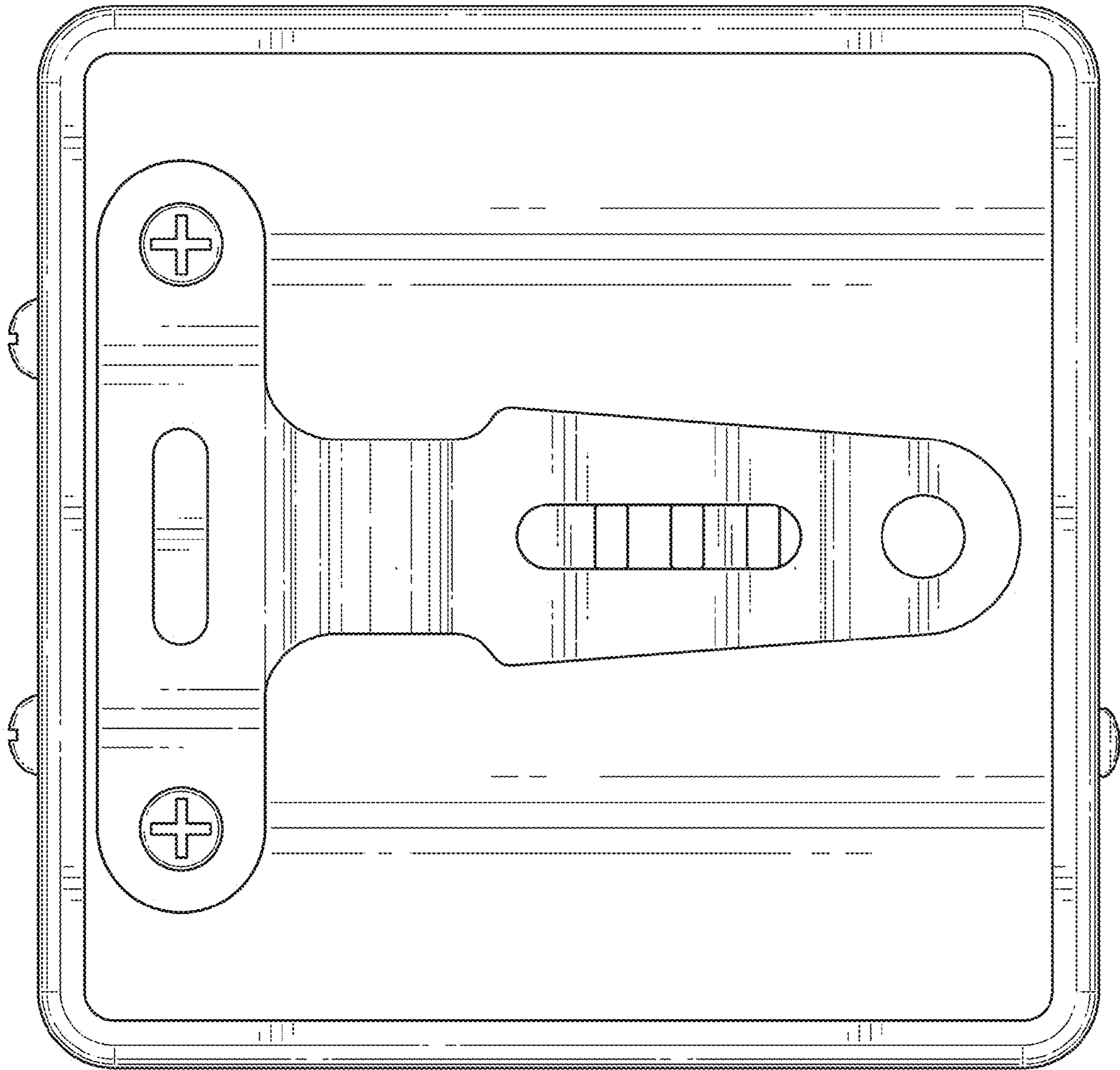

FIG. 3

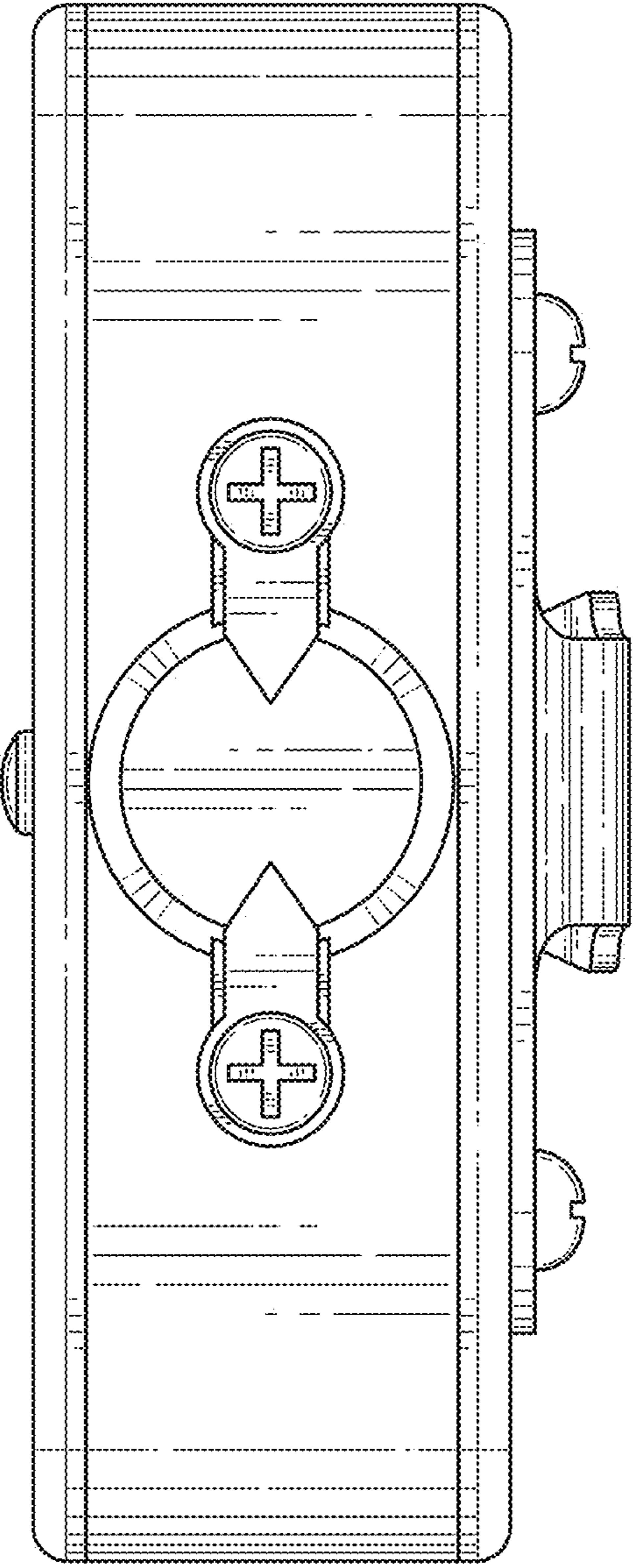

FIG. 4

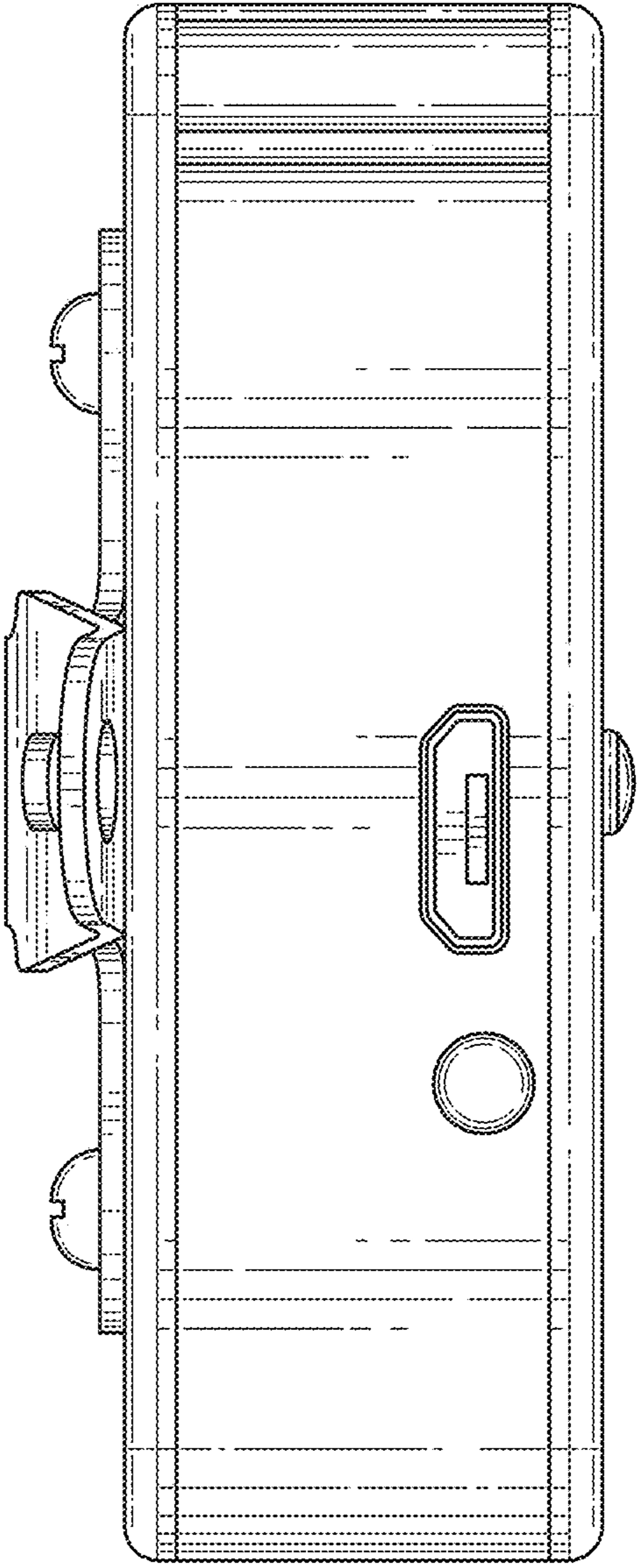

FIG. 5

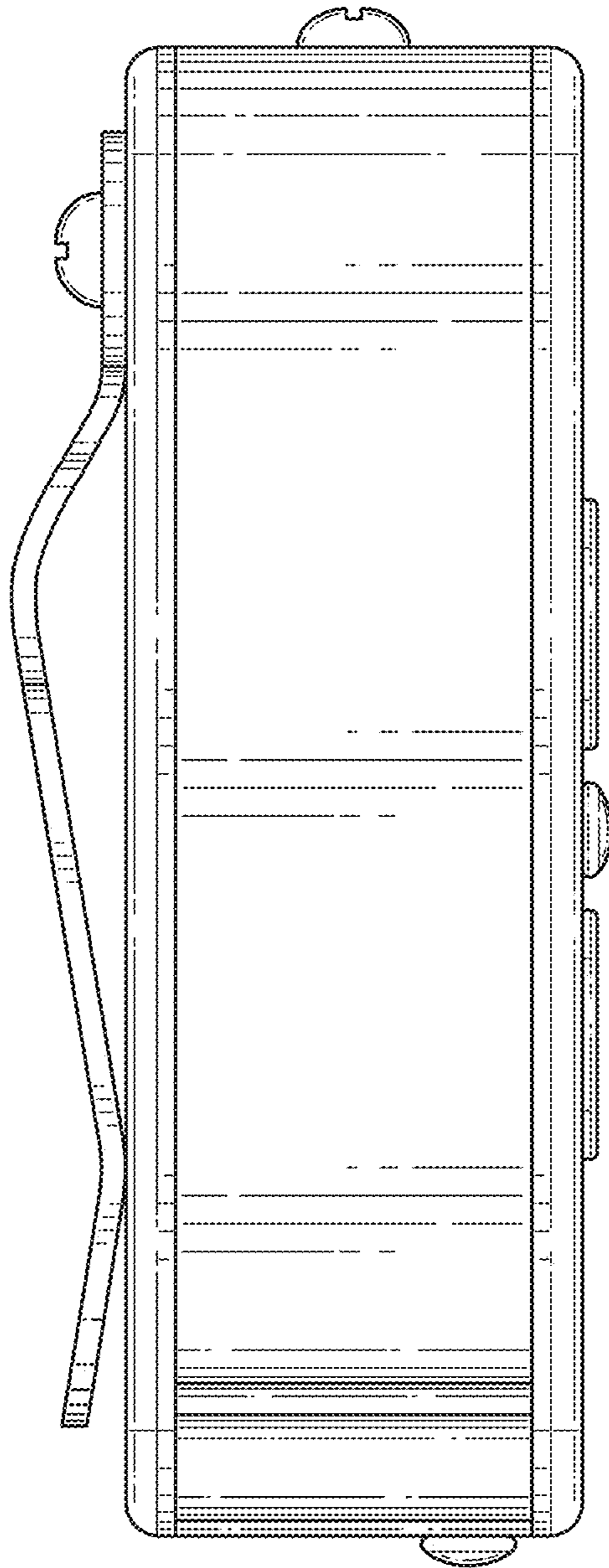

FIG. 6

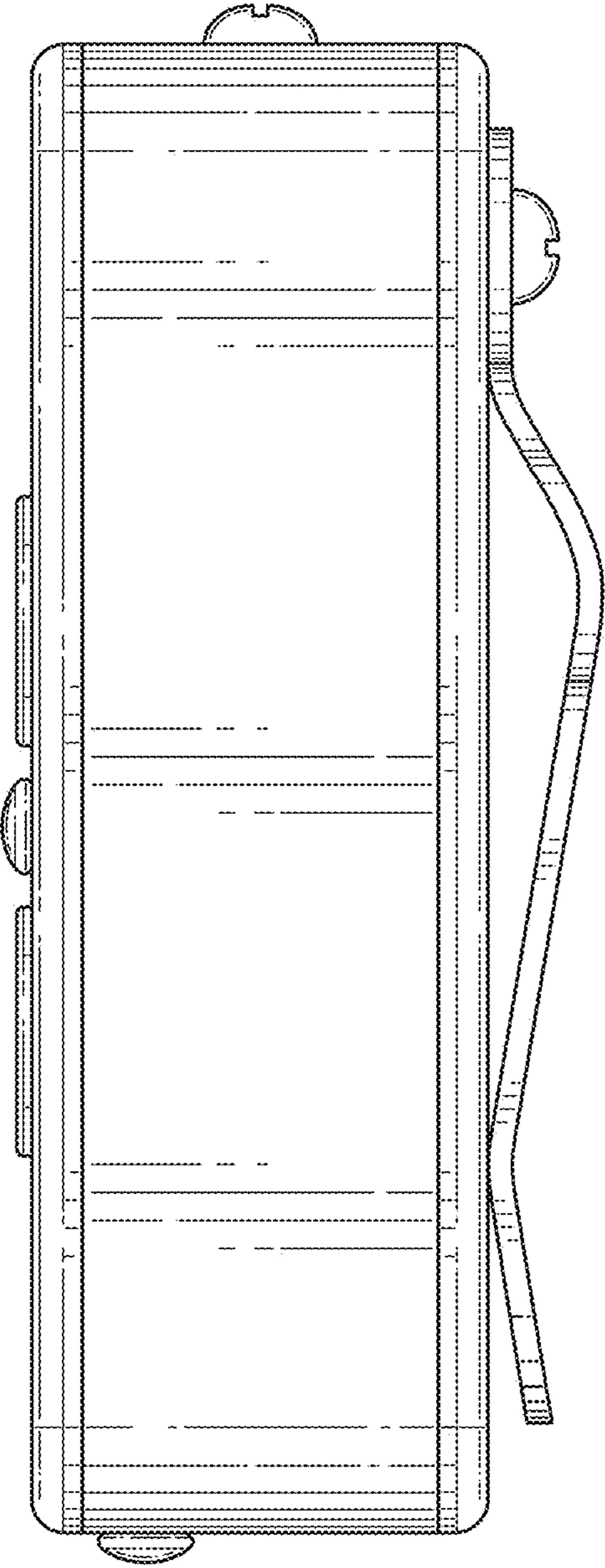

FIG. 7