



US00D889581S

(12) **United States Design Patent** (10) **Patent No.:** **US D889,581 S**  
**Facteau et al.** (45) **Date of Patent:** **\*\* Jul. 7, 2020**

(54) **MORTAR TRAINING AID**  
(71) Applicant: **U.S. Government as Represented by the Secretary of the Army**, Picatinny Arsenal, Dover, NJ (US)  
(72) Inventors: **Robert J. Facteau**, Troy, NY (US); **Joshua W. Ward**, Fort Polk, LA (US); **George E. Hathaway, IV**, Watervliet, NY (US); **Karolanne L. Madulka**, Ballston Spa, NY (US); **Wayland P. Barber**, Mechanicville, NY (US); **Brian J. Van De Wal**, Schodack, NY (US)

(73) Assignee: **The United States of America as Represented by the Secretary of the Army**, Washington, DC (US)

(\*\*) Term: **15 Years**

(21) Appl. No.: **29/654,742**

(22) Filed: **Jun. 27, 2018**

(51) **LOC (12) Cl.** ..... **22-01**

(52) **U.S. Cl.**  
USPC ..... **D22/100**

(58) **Field of Classification Search**  
USPC ..... D22/100, 101, 103, 104, 105, 108, 107, D22/109, 110, 111, 199; D21/567, 569, D21/570, 571, 573, 574, 575  
CPC ..... F41G 1/30; F41G 3/26; F42B 5/28; F41C 23/16; F41A 23/16; F41A 23/18; F41A 9/83; F41A 33/00

See application file for complete search history.

(56) **References Cited**

**U.S. PATENT DOCUMENTS**

186,651 A \* 1/1877 White ..... F41B 1/00 124/62  
D56,063 S \* 8/1920 Griffith ..... D21/569

D143,597 S \* 1/1946 Kanngiesser ..... D21/569  
2,600,116 A \* 6/1952 Kopf ..... F41B 7/00 124/26  
D170,153 S \* 8/1953 Davis et al. .... D21/569  
D189,924 S \* 3/1961 Robbins ..... D21/569  
D207,268 S \* 3/1967 Rosenbloom ..... D21/569  
3,371,578 A \* 3/1968 Choate ..... F41A 33/00 89/1.813  
3,890,879 A \* 6/1975 Looger ..... F41F 3/0455 89/1.816  
4,198,897 A \* 4/1980 Lipp ..... F41A 9/27 89/13.05

(Continued)

**OTHER PUBLICATIONS**

“Original U.S. WWII M1 81mm Display Mortar with Commando Base Plate” [online]. ima-usa.com. [Retrieved on Aug. 22, 2019]. Retrieved from the Internet: <https://www.ima-usa.com/collections/mortars/products/original-u-s-wwii-m1-81mm-display-mortar-with-commando-b>.\*

(Continued)

*Primary Examiner* — Khawaja Anwar

*Assistant Examiner* — Mojtaba Tehrani

(74) *Attorney, Agent, or Firm* — John P. DiScala

(57) **CLAIM**

The ornamental design for a mortar training aid, as shown and described.

**DESCRIPTION**

FIG. 1 is a top perspective view of a mortar training aid, showing our new design.

FIG. 2 is a left elevation view thereof;

FIG. 3 is a top plan view thereof;

FIG. 4 is a right elevation view thereof;

FIG. 5 is a rear elevation view thereof; and,

FIG. 6 is a front elevation view thereof.

Evenly spaced broken lines are disclaimed portions of the mortar training aid and form no part of the claimed design.

**1 Claim, 5 Drawing Sheets**

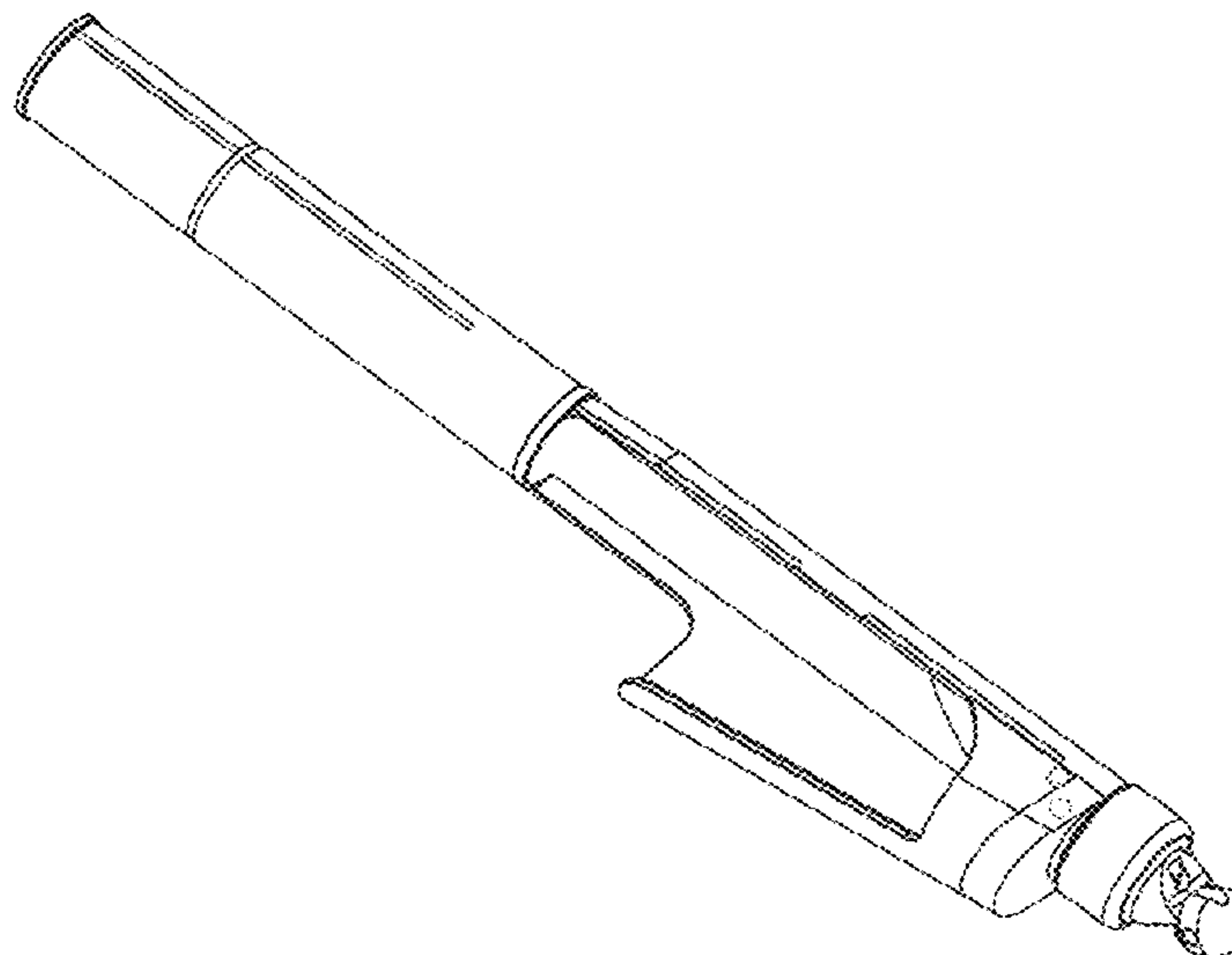

(56)

References Cited

U.S. PATENT DOCUMENTS

4,721,026 A \* 1/1988 Arana Ibarra ..... F41A 27/06  
89/37.05  
D348,700 S \* 7/1994 Lin ..... D21/570  
D355,000 S \* 1/1995 Arad ..... D21/570  
5,429,032 A \* 7/1995 Cytron ..... F41A 23/54  
89/1.35  
6,059,573 A \* 5/2000 Patel ..... F41G 3/30  
434/16  
6,193,517 B1 \* 2/2001 Lazecki ..... F42B 8/20  
434/12  
6,321,632 B1 \* 11/2001 Holmes ..... F41A 23/08  
89/37.01  
7,421,934 B1 \* 9/2008 Madulka ..... F41A 33/00  
102/445  
7,681,483 B1 \* 3/2010 Rhoades ..... F41A 21/10  
89/135  
7,735,408 B1 \* 6/2010 Becker ..... F41F 1/06  
102/374  
7,963,202 B1 \* 6/2011 Becker ..... F41F 1/06  
42/76.01  
8,141,469 B1 \* 3/2012 Holmes ..... F41A 3/08  
89/17

8,272,307 B1 \* 9/2012 Holmes ..... F41A 3/30  
124/66  
8,782,939 B2 \* 7/2014 Constant ..... F41A 3/22  
42/69.01  
8,813,629 B1 \* 8/2014 Holmes ..... F41A 3/06  
89/18  
9,207,044 B2 \* 12/2015 Brown ..... F41G 1/50  
9,863,732 B2 \* 1/2018 Curliss ..... F41F 1/06  
2006/0288854 A1 \* 12/2006 Witherell ..... F41A 21/20  
89/14.05  
2007/0221051 A1 \* 9/2007 Burkholder ..... F41A 21/34  
89/1.35  
2016/0238344 A1 8/2016 Jandl

OTHER PUBLICATIONS

“Airsoft Mortar Shoots 140 Meters | 460 Feet?” [online]. NOVITSCH. [Published on Oct 16, 2017]. Retrieved from the Internet: <https://www.youtube.com/watch?v=rroGF-TKfRk>.  
“10 Pound 60mm Ultra Light Mortar Adopted by Polish Special Forces Group” [online]. Nathaniel F. [Published Jul. 14, 2017]. Retrieved from the Internet: <https://www.thefirearmblog.com/blog/2017/07/14/10lb-60mm-ultra-light-mortar-adopted-polish-special-forces-group/>.

\* cited by examiner

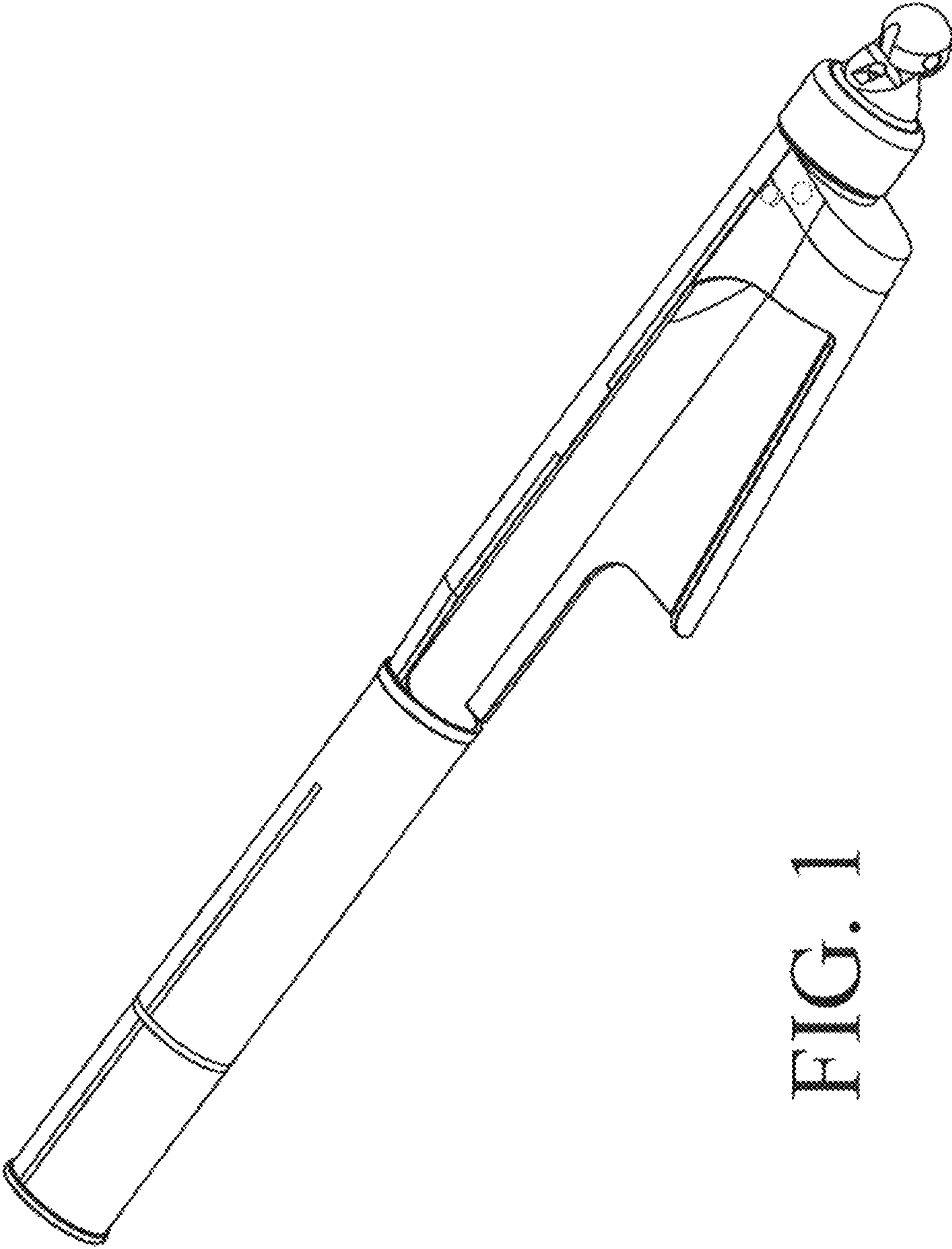

FIG. 1

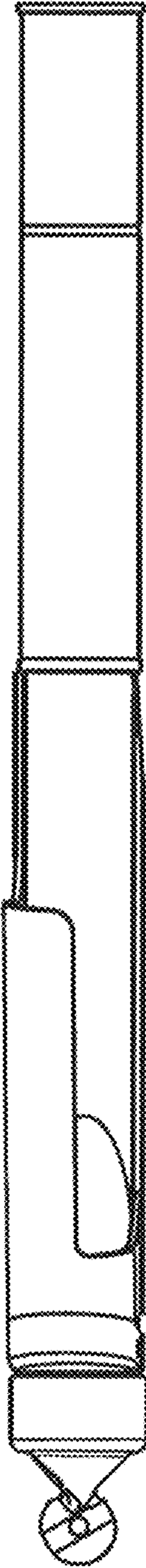

FIG. 2

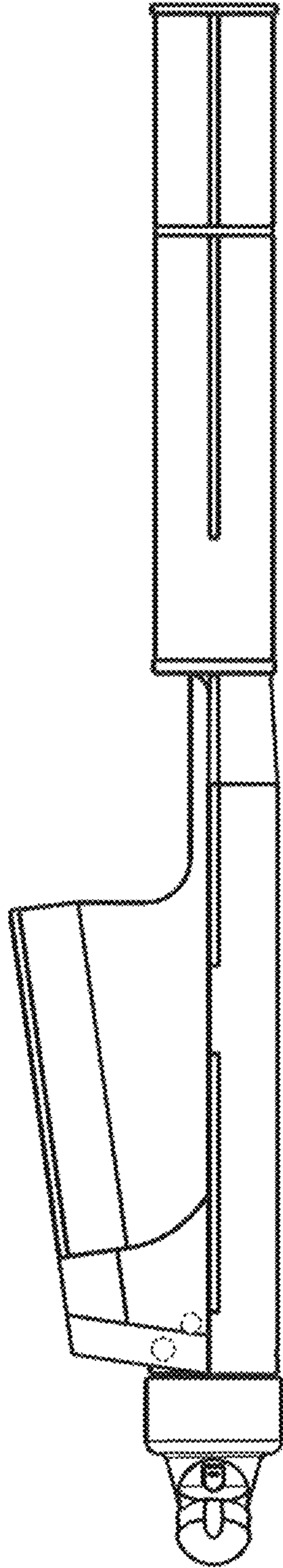

FIG. 3



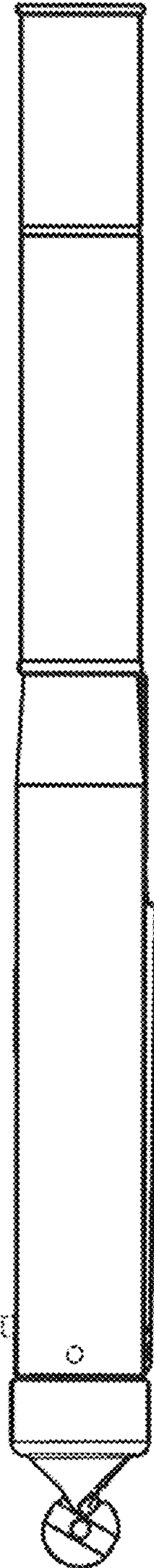

FIG. 4

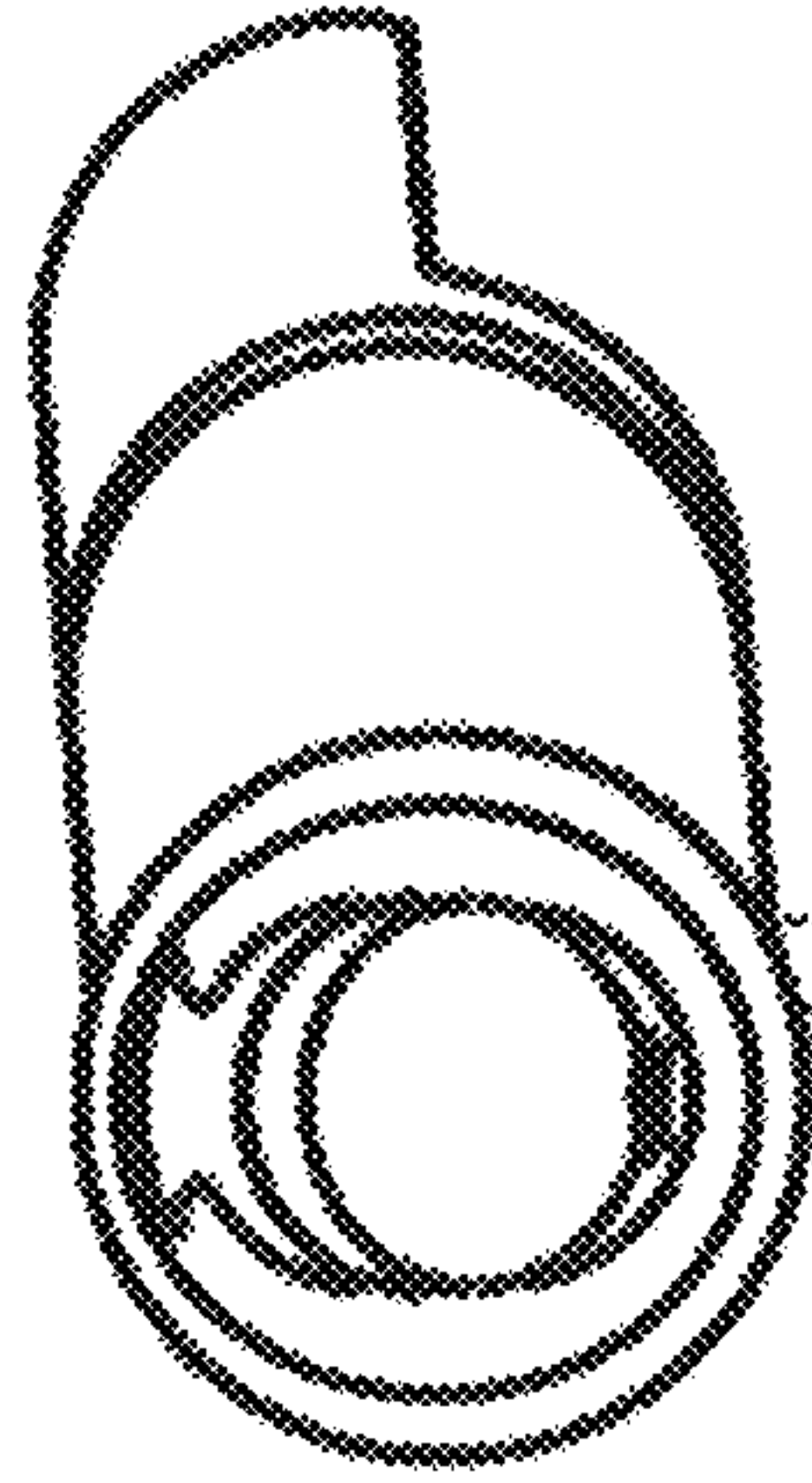

FIG. 5

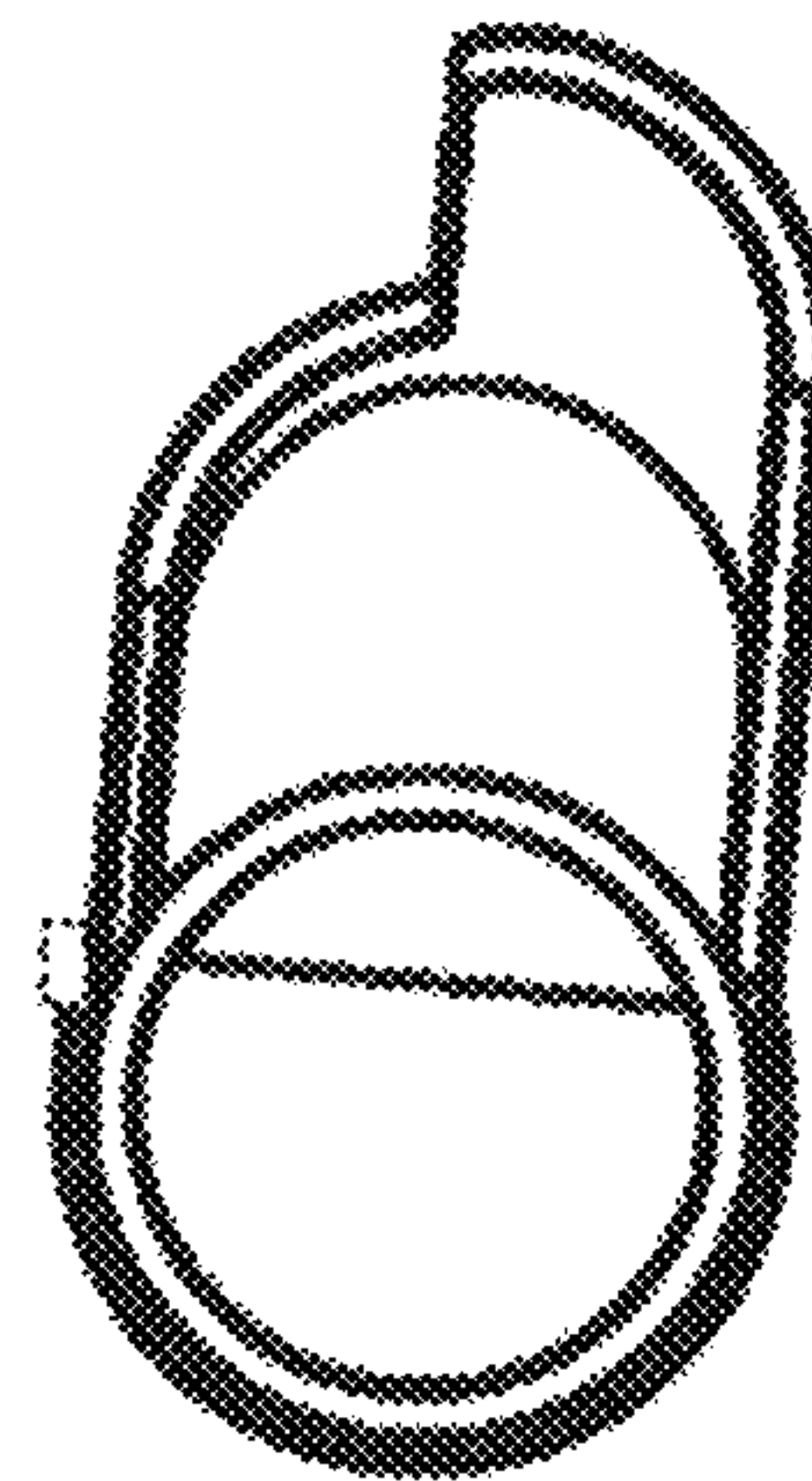

FIG. 6