



US00D889554S

(12) **United States Design Patent** (10) **Patent No.:** **US D889,554 S**
Calhoun Lewis et al. (45) **Date of Patent:** **** Jul. 7, 2020**

(54) **GAME TOWER**

(56) **References Cited**

(71) Applicant: **AGS LLC**, Las Vegas, NV (US)

U.S. PATENT DOCUMENTS

(72) Inventors: **Rachel Marie Calhoun Lewis**, Atlanta, GA (US); **Ian Robert Scott**, Duluth, GA (US); **Karl Frederick Zedell, Jr.**, Alpharetta, GA (US)

4,440,457 A 4/1984 Fogelman et al.
 D275,117 S 8/1984 Heywood
 4,844,567 A 7/1989 Chalabian
 (Continued)

(73) Assignee: **AGS LLC**, Las Vegas, NV (US)

FOREIGN PATENT DOCUMENTS

(**) Term: **15 Years**

AU 338369 9/2011
 AU 201711655 4/2017
 (Continued)

(21) Appl. No.: **29/689,836**

OTHER PUBLICATIONS

(22) Filed: **May 2, 2019**

Bluebird Slant Widescreen literature from www.wms.com/technologyandinnovation_cabinets_widescreeen.php dated May 19, 2009, showing a giuning machine cabinet that was sold and/or publicly disclosed at least as early as Dec. 13, 2008.

(Continued)

Related U.S. Application Data

(60) Division of application No. 29/640,521, filed on Mar. 15, 2018, now Pat. No. Des. 848,534, which is a continuation of application No. 29/540,396, filed on Sep. 24, 2015, now Pat. No. Des. 813,954.

Primary Examiner — Ryan Harvey

(74) *Attorney, Agent, or Firm* — Weide & Miller, Ltd.

(51) **LOC (12) Cl.** **21-03**

(57) **CLAIM**

The ornamental design for a game tower, as shown and described.

(52) **U.S. Cl.**

USPC **D21/369**

DESCRIPTION

(58) **Field of Classification Search**

USPC D21/369, 370, 371, 385, 329, 325, 394;
 D14/307, 172, 129, 325, 401, 371, 126,
 D14/439, 432, 450, 128, 375; 463/28,
 463/13, 11, 16, 20, 25, 31, 46, 23, 30, 17,
 463/36, 29, 42, 34, 32, 35, 19, 21, 22;
 273/292, 203, 138.2, 143 R, 142 R, 138.1;
 D19/60; D16/226; D8/335, 331, 334;
 D26/14
 CPC G07F 17/32; G07F 17/34; G07F 17/3211;
 G07F 17/3244; G07F 17/3267

FIG. 1 is a front perspective view of the claimed design in an environment;
 FIG. 2 is a front view of the claimed design of FIG. 1;
 FIG. 3 is a rear view of the claimed design of FIG. 1;
 FIG. 4 is a right side view of the claimed design of FIG. 1;
 FIG. 5 is a left side view of the claimed design of FIG. 1;
 FIG. 6 is a top plan view of the claimed design of FIG. 1;
 and,
 FIG. 7 is a bottom plan view of the claimed design of FIG. 1.
 The broken line showing of portions of the game tower depicts environment and forms no part of the claim.

See application file for complete search history.

1 Claim, 6 Drawing Sheets

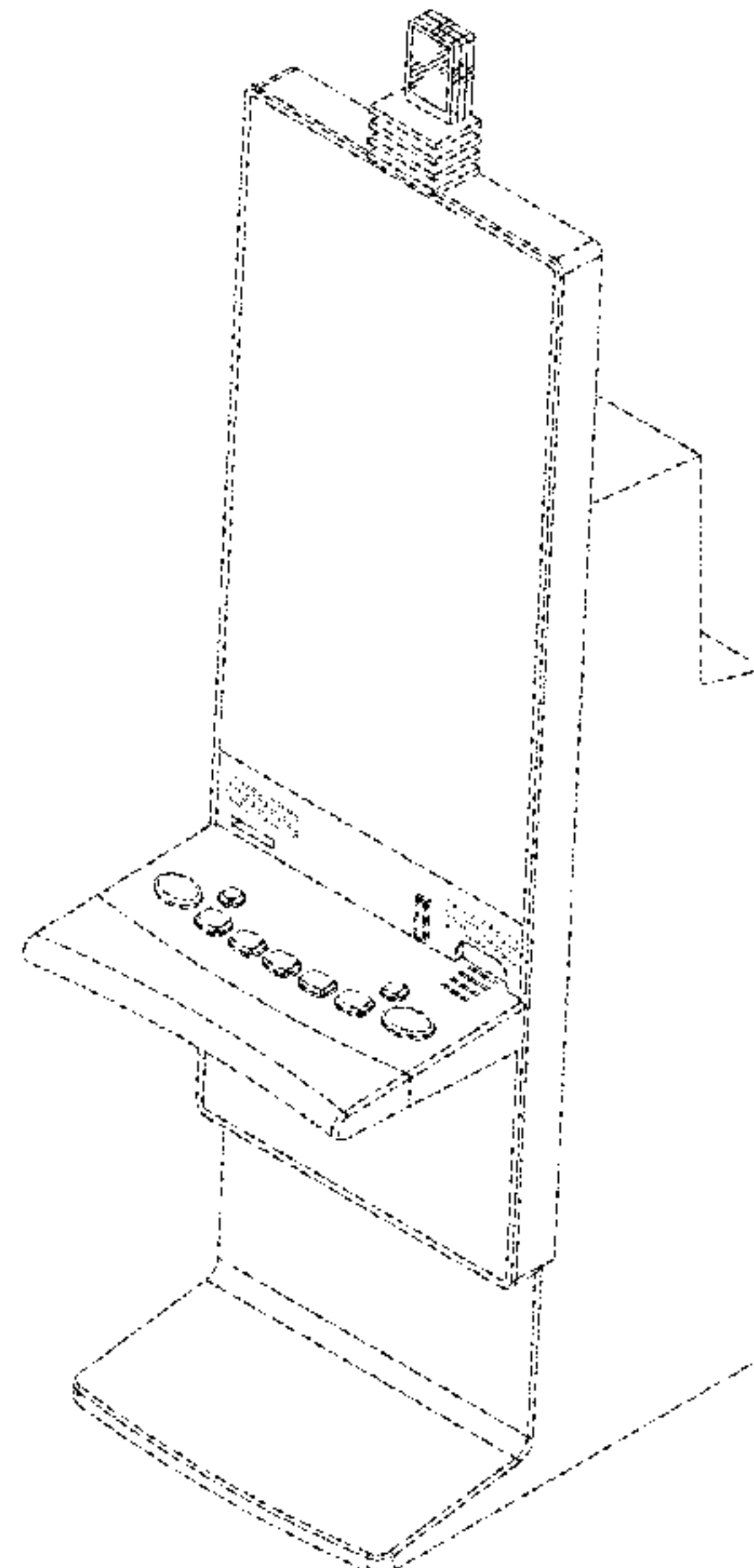

(56)

References Cited

U.S. PATENT DOCUMENTS

4,918,579	A	4/1990	Bennett	6,897,624	B2	5/2005	Lys et al.
D307,771	S	5/1990	Cesaroni et al.	6,899,626	B1	5/2005	Luciano et al.
5,057,827	A	10/1991	Nobile et al.	6,906,860	B2	6/2005	Starkweather
5,108,099	A	4/1992	Smyth	D508,268	S	8/2005	Hanchar et al.
5,113,990	A	5/1992	Gabrius et al.	D508,719	S	8/2005	de Haas
D333,164	S	2/1993	Kraft et al.	D508,961	S	8/2005	Gatto et al.
5,302,965	A	4/1994	Belcher et al.	6,948,829	B2	9/2005	Verdes et al.
D352,330	S	11/1994	Smith	D513,044	S	12/2005	Morrison
5,381,502	A	1/1995	Veligdan	6,997,810	B2	2/2006	Cole
5,521,587	A	5/1996	Sawabe et al.	7,014,563	B2	3/2006	Stephan et al.
D373,809	S	9/1996	Hirato	D523,092	S	6/2006	Karlsson
5,561,346	A	10/1996	Byrne	D525,664	S	7/2006	Cole
D378,604	S	3/1997	Brettschneider	7,123,811	B1	10/2006	Chen et al.
D380,014	S	6/1997	Yang	D535,338	S	1/2007	Linard et al.
D381,697	S	7/1997	Brettschneider	7,178,941	B2	2/2007	Roberge et al.
D381,700	S	7/1997	Brettschneider	7,213,941	B2	5/2007	Sloan et al.
5,670,971	A	9/1997	Tokimoto et al.	7,237,925	B2	7/2007	Mayer et al.
D386,796	S	11/1997	Komori	7,284,876	B2	10/2007	Ericson
D388,469	S	12/1997	Dickenson et al.	D554,708	S	11/2007	Gutknecht et al.
5,695,402	A	12/1997	Stupak	D557,348	S	12/2007	Gutknecht et al.
5,813,914	A	9/1998	McKay et al.	D557,349	S	12/2007	Linard et al.
5,818,401	A	10/1998	Wang	D559,917	S	1/2008	Cole
5,826,882	A	10/1998	Ward	D560,724	S	1/2008	Johnson
5,836,819	A	11/1998	Ugawa	D560,725	S	1/2008	Johnson
D407,758	S	4/1999	Isetani et al.	7,331,694	B2	2/2008	Lee et al.
D410,039	S	5/1999	McClellan	D563,481	S	3/2008	Looks et al.
D413,635	S	9/1999	Taylor	D564,601	S	3/2008	Strahinic et al.
D421,631	S	3/2000	Tsuda	7,339,782	B1	3/2008	Landes et al.
D424,122	S	5/2000	Dickenson et al.	D566,197	S	4/2008	Greenberg et al.
6,068,101	A	5/2000	Dickenson et al.	7,355,573	B2	4/2008	Ogawa
D428,062	S	7/2000	Hayashi	7,364,505	B2	4/2008	Mattice et al.
6,095,526	A	8/2000	Cook, II	7,367,145	B2	5/2008	Mou
6,135,884	A	10/2000	Hedrick et al.	7,367,685	B2	5/2008	Moll
6,164,645	A	12/2000	Weiss	7,390,257	B2	6/2008	Paulsen et al.
D436,380	S	1/2001	Brettschneider	D573,200	S	7/2008	Hashimoto et al.
6,176,584	B1	1/2001	Best et al.	D573,201	S	7/2008	Hashimoto et al.
6,183,109	B1	2/2001	Nelson et al.	7,397,387	B2	7/2008	Suzuki et al.
6,186,645	B1	2/2001	Camarota	7,423,864	B2	9/2008	Kim et al.
6,201,703	B1	3/2001	Yamada et al.	7,442,125	B2	10/2008	Paulsen et al.
D439,931	S	4/2001	Yamaguchi	7,476,154	B2	1/2009	Kogo et al.
D442,640	S	5/2001	Hayashi	D586,866	S	2/2009	Hsu
6,265,984	B1	7/2001	Molinaroli	7,506,463	B2	3/2009	Hoist
D446,252	S	8/2001	Yamaguchi	7,506,997	B1	3/2009	Eriksson
D447,052	S	8/2001	Goserud	7,513,830	B2	4/2009	Hajder et al.
6,278,419	B1	8/2001	Malkin	D592,053	S	5/2009	Suzuki
6,283,608	B1	9/2001	Straat	D592,709	S	5/2009	McComb et al.
6,319,125	B1	11/2001	Acres	D599,859	S	9/2009	Lesley et al.
6,332,690	B1	12/2001	Murofushi	D602,772	S	10/2009	Suzuki et al.
6,334,612	B1	1/2002	Wurz et al.	D603,909	S	11/2009	De Viveiros Ortiz
D456,750	S	5/2002	McWilliams et al.	D604,368	S	11/2009	Lesley et al.
D459,402	S	6/2002	Wurz et al.	D605,231	S	12/2009	Hashimoto et al.
D460,915	S	7/2002	Lynch	7,641,554	B2	1/2010	Paulsen et al.
6,443,837	B1	9/2002	Jaffe et al.	7,654,899	B2	2/2010	Durham et al.
D464,377	S	10/2002	Wurz et al.	7,667,891	B2	2/2010	Cok et al.
D466,160	S	11/2002	Hirato et al.	D613,802	S	4/2010	Meyers et al.
6,475,087	B1	11/2002	Cole	D615,598	S	5/2010	McComb et al.
D471,594	S	3/2003	Nojo	D616,039	S	5/2010	Bruzzese et al.
6,577,286	B1	6/2003	Jang	7,708,640	B2	5/2010	Burak et al.
6,578,847	B1	6/2003	Hendrick et al.	D619,177	S	7/2010	Lee
6,579,174	B1	6/2003	Lane et al.	D619,660	S	7/2010	Cole et al.
6,592,238	B2	7/2003	Cleaver et al.	D622,323	S	8/2010	De Viveiros Ortiz
D481,078	S	10/2003	Stephan	7,803,053	B2	9/2010	Atkinson
6,641,484	B2	11/2003	Oles et al.	D626,182	S	10/2010	Cole et al.
6,682,418	B1	1/2004	Mendes et al.	D626,183	S	10/2010	Cole et al.
6,702,409	B2	3/2004	Hedrick et al.	D627,008	S	11/2010	Bruzzese et al.
D489,417	S	5/2004	Munoz et al.	7,826,006	B2	11/2010	Koganezawa
D492,676	S	7/2004	Monson et al.	7,828,461	B2	11/2010	Mayer et al.
6,776,504	B2	8/2004	Sloan et al.	7,833,102	B2	11/2010	Beadell et al.
D495,754	S	9/2004	Wurz et al.	D632,342	S	2/2011	Wen
D495,755	S	9/2004	Wurz et al.	D633,950	S	3/2011	Terpstra et al.
D496,407	S	9/2004	Gadda et al.	D636,822	S	4/2011	Levitan et al.
D498,267	S	11/2004	Crouch	7,927,218	B2	4/2011	Kopera et al.
D499,019	S	11/2004	Sagmeister et al.	7,966,485	B2	6/2011	Chen et al.
6,834,979	B1	12/2004	Cleaver et al.	D646,336	S	10/2011	Kelly et al.
6,860,814	B2	3/2005	Cole	D649,605	S	11/2011	Terpstra et al.
				8,054,243	B2	11/2011	Sokolov et al.
				8,075,385	B2	12/2011	Jackson
				8,241,124	B2	8/2012	Kelly et al.
				8,272,957	B2	9/2012	Crowder, Jr. et al.

(56)

References Cited

U.S. PATENT DOCUMENTS

D671,425 S	11/2012	Huljak et al.	D833,534 S	11/2018	Lee et al.
D673,619 S	1/2013	Seelig	D834,652 S	11/2018	Lee et al.
D673,620 S	1/2013	Johnson et al.	D835,841 S	12/2018	Xu
D673,621 S	1/2013	Johnson et al.	D836,164 S	12/2018	Castro et al.
D677,736 S	3/2013	Dorn et al.	D842,930 S	3/2019	Johnson et al.
D678,761 S	3/2013	Cooper	D842,932 S	3/2019	Stair et al.
8,430,756 B2	4/2013	McComb et al.	D842,933 S	3/2019	Castro et al.
D684,216 S	6/2013	Terpstra et al.	D843,458 S	3/2019	Castro et al.
D684,637 S	6/2013	Shelley et al.	D843,459 S	3/2019	Castro et al.
D685,033 S	6/2013	Wudtke	D843,460 S	3/2019	Castro et al.
D685,435 S	7/2013	Hohman et al.	D843,461 S	3/2019	Castro et al.
8,550,913 B2	10/2013	Kelly et al.	D843,467 S	3/2019	Johnson et al.
D696,109 S	12/2013	Wilker	D843,468 S	3/2019	Johnson et al.
D697,558 S	1/2014	Myers et al.	D843,473 S	3/2019	Zedell, Jr. et al.
8,651,963 B1	2/2014	Thompson	D843,474 S	3/2019	Lesley et al.
D701,114 S	3/2014	Baumwald et al.	D843,475 S	3/2019	Lesley et al.
D704,273 S	5/2014	Chudek	D843,476 S	3/2019	Lesley et al.
D705,872 S	5/2014	Ortiz	D843,477 S	3/2019	Lesley et al.
D706,741 S	6/2014	Myers	D843,478 S	3/2019	Lesley et al.
D707,646 S	6/2014	Kim et al.	D843,479 S	3/2019	Lesley et al.
D708,676 S	7/2014	Ballman et al.	D843,480 S	3/2019	Lesley et al.
8,814,707 B2	8/2014	Slattery	D843,482 S	3/2019	Holland et al.
D712,975 S	9/2014	Lesley et al.	D844,062 S	3/2019	Lesley et al.
8,827,819 B2	9/2014	Thompson	D844,063 S	3/2019	Lee et al.
D714,875 S	10/2014	Wudtke et al.	D847,905 S *	5/2019	Lewis D21/369
D715,364 S	10/2014	Wudtke et al.	D848,534 S *	5/2019	Calhoun D21/369
8,851,989 B2	10/2014	Rosander et al.	2003/0064814 A1	4/2003	Stephan et al.
D719,615 S	12/2014	Inoue et al.	2004/0001335 A1	1/2004	Wu
D719,616 S	12/2014	Inoue et al.	2004/0053663 A1	3/2004	Paulsen et al.
D720,211 S	12/2014	Brown et al.	2004/0053699 A1	3/2004	Rasmussen et al.
D721,766 S	1/2015	Ferrazoli	2004/0224776 A1	11/2004	Nagano
D721,767 S	1/2015	Ferrazoli	2004/0229698 A1	11/2004	Lind et al.
D723,022 S	2/2015	Miles	2005/0059486 A1	3/2005	Kaminkow
D723,626 S	3/2015	Vasquez et al.	2005/0130746 A1	6/2005	Stephenson, III et al.
8,974,297 B2	3/2015	Massing et al.	2005/0215325 A1	9/2005	Nguyen et al.
D727,431 S	4/2015	Themann	2005/0261057 A1	11/2005	Bleich et al.
D730,993 S	6/2015	Castro et al.	2006/0030412 A1	2/2006	Cole
D732,520 S	6/2015	Themann	2006/0073900 A1	4/2006	Cole
D733,088 S	6/2015	Garneau et al.	2006/0094511 A1	5/2006	Roireau
9,064,372 B2	6/2015	Rasmussen et al.	2006/0100013 A1	5/2006	Enzminger
D740,887 S	10/2015	Randazzo	2006/0131810 A1	6/2006	Nicely
D740,888 S	10/2015	DePalma et al.	2006/0183552 A1	8/2006	DiMichele
D742,974 S	11/2015	Lesley	2006/0193124 A1	8/2006	Moll
D742,975 S	11/2015	Myers et al.	2006/0205498 A1	9/2006	Kogo et al.
D745,093 S	12/2015	Weiss et al.	2007/0010318 A1	1/2007	Rigsby et al.
D756,236 S	5/2016	DePaz et al.	2007/0035965 A1	2/2007	Holst
D760,846 S	7/2016	Castro et al.	2007/0060387 A1	3/2007	Enzminger et al.
D762,613 S	8/2016	Garneau et al.	2007/0149291 A1	6/2007	Mitchell
D763,361 S	8/2016	Rosander et al.	2007/0159820 A1	7/2007	Crandell et al.
RE46,169 E	10/2016	Kelly et al.	2007/0171640 A1	7/2007	Sloan et al.
D770,090 S	10/2016	Zahr et al.	2007/0197301 A1	8/2007	Cole
9,478,097 B2	10/2016	Hennessy et al.	2007/0225079 A1	9/2007	Cole
9,504,919 B2	11/2016	Taylor et al.	2007/0287527 A1	12/2007	Tanabe et al.
D776,801 S	1/2017	Tamura et al.	2007/0287528 A1	12/2007	Hirato et al.
9,573,050 B2	2/2017	Thompson et al.	2007/0287544 A1	12/2007	Hirato et al.
9,679,435 B2	6/2017	Schrementi et al.	2008/0020838 A1	1/2008	Slattery
9,711,001 B2	7/2017	Zedell, Jr. et al.	2008/0076553 A1	3/2008	Paulsen et al.
9,745,107 B2	8/2017	Zahr et al.	2008/0113794 A1	5/2008	Cole
D798,389 S	9/2017	Weiss et al.	2008/0119288 A1	5/2008	Rasmussen
D801,437 S	10/2017	Hohman	2008/0186415 A1	8/2008	Boud et al.
D803,323 S	11/2017	Bussey et al.	2008/0194313 A1	8/2008	Walker
D803,324 S	11/2017	Bussey et al.	2008/0227522 A1	9/2008	Toyoda
D810,833 S	2/2018	Rosander et al.	2008/0248852 A1	10/2008	Rasmussen
D812,146 S	3/2018	Castro et al.	2008/0268949 A1	10/2008	Dell
D812,147 S	3/2018	Castro et al.	2008/0311987 A1	12/2008	Hirato
D812,148 S	3/2018	Castro et al.	2009/0011839 A1	1/2009	Cole
D812,149 S	3/2018	Castro et al.	2009/0036208 A1	2/2009	Pennington et al.
D813,954 S	3/2018	Calhoun et al.	2009/0045723 A1	2/2009	Ishikawa
D818,048 S	5/2018	Calhoun et al.	2009/0179597 A1	7/2009	Salmon
D819,747 S	6/2018	Castro et al.	2009/0247261 A1	10/2009	Koami
D820,915 S	6/2018	Lee et al.	2009/0275389 A1	11/2009	Englman et al.
D822,117 S	7/2018	Costa	2010/0016084 A1	1/2010	Bleich et al.
D826,338 S	8/2018	Bussey et al.	2010/0020546 A1	1/2010	Kukita
D832,355 S	10/2018	Castro et al.	2010/0120518 A1	5/2010	Borissov et al.
D832,356 S	10/2018	Castro et al.	2010/0120541 A1	5/2010	Lesley
			2010/0137060 A1	6/2010	Cole
			2011/0118034 A1	5/2011	Jaffe
			2011/0136573 A1	6/2011	McComb et al.
			2011/0195775 A1	8/2011	Wells

(56)

References Cited

U.S. PATENT DOCUMENTS

2011/0319152 A1 12/2011 Ross et al.
 2012/0178523 A1 7/2012 Greenberg
 2013/0084948 A1 4/2013 Watkins et al.
 2014/0087887 A1 3/2014 Chudek
 2014/0132891 A1 5/2014 Tohyama
 2014/0206432 A1 7/2014 Radek
 2014/0250409 A1 9/2014 Shah et al.
 2014/0256409 A1 9/2014 Wood et al.
 2014/0268876 A1 9/2014 Lee et al.
 2014/0323212 A1 10/2014 Thompson et al.
 2015/0087403 A1 3/2015 Castro et al.
 2015/0141113 A1 5/2015 Melnick et al.
 2015/0269810 A1 9/2015 Wolf
 2015/0336005 A1 11/2015 Melnick et al.
 2017/0178443 A1 6/2017 Calhoun et al.
 2017/0178444 A1 6/2017 Lee et al.
 2018/0075689 A1 3/2018 Castro et al.
 2018/0078854 A1 3/2018 Achmueller et al.
 2018/0082523 A1 3/2018 Palermo et al.
 2018/0165913 A1 6/2018 Ito et al.
 2018/0342129 A1 11/2018 Wudtke et al.
 2019/0012874 A1 1/2019 Goldstein et al.
 2019/0073879 A1 3/2019 Marks
 2019/0096161 A1 3/2019 Barbour et al.
 2019/0096166 A1 3/2019 Shimizu et al.
 2019/0096169 A1 3/2019 Tovar et al.
 2019/0096170 A1 3/2019 Lewis et al.
 2019/0096173 A1 3/2019 Brandau et al.
 2019/0096174 A1 3/2019 Ambrecht et al.
 2019/0102974 A1 4/2019 Bussey et al.
 2019/0102983 A1 4/2019 Gallagher et al.
 2019/0102984 A1 4/2019 Gallagher et al.

FOREIGN PATENT DOCUMENTS

AU 201713995 7/2017
 AU 201713998 7/2017
 CL 201000683 12/2011
 CL 201302246 2/2014
 CL 201702159 10/2017
 CN 1449298 10/2003
 CN 302535459 8/2013
 CN 302781022 4/2014
 CN 303133978 3/2015
 CN 105308656 2/2016
 CN 303617588 3/2016
 CN 303932486 11/2016
 CN 304030396 2/2017
 CN 304030398 2/2017
 CN 304081281 3/2017
 CN 304104111 4/2017
 CN 304201004 7/2017
 CN 304284046 9/2017
 CN 304284113 9/2017
 CN 304287919 9/2017
 DE 49812561-0001 7/1999
 DE 49812561-0002 7/1999
 DE 49812561-0003 7/1999
 DE 49812561-0004 7/1999
 DE 40108464-0001 5/2002
 DE 40202624-0001 5/2002
 DE 102014016643 5/2016
 EM 000227822-0005 9/2004
 EM 000776687-0003 8/2007
 EM 000857347-0009 1/2008
 EM 000972724-0001 7/2008
 EM 000975727-0001 7/2008

EM 001598418-0004 8/2009
 EM 001688540-0002 3/2010
 EM 001724873-0005 6/2010
 EM 002081661-0005 7/2012
 JP D1135500 1/2002
 JP D1137636 2/2002
 JP D1144223 4/2002
 JP 3443415 9/2003
 JP 2006-37425 2/2006
 JP 4264361 5/2009
 JP 4792318 10/2011
 JP 2013-78625 5/2013
 JP 5294616 9/2013
 JP 5317478 10/2013
 JP D1502479 6/2014
 JP D1502928 6/2014
 JP D1512277 10/2014
 JP D1525593 5/2015
 JP D1529194 6/2015
 JP D1536549 10/2015
 JP D1536665 10/2015
 JP 6018136 11/2016
 JP 2017-06582 1/2017
 JP D1589479 10/2017
 JP D1589480 10/2017
 KR 300710844 9/2013
 KR 300755913 8/2014
 KR 20150105999 9/2015
 KR 101677267 11/2016
 TW D169011 7/2015
 TW D177195 7/2016
 WO D093245-0001 11/2016

OTHER PUBLICATIONS

Spec International, Inc., GEN-311 gaming machine cabinet, publicly disclosed at least as early as Dec. 13, 2008.
 International Search Report and Written Opinion for PCT/US16/66904 dated Apr. 25, 2017, 12 pages.
 Icon by AGS, <http://www.playags.com/portfolio/icon/>, 3 pages, Feb. 23, 2016.
 Orion by AGS, <http://www.playags.com/portfolio/orion/>, 3 pages, Sep. 15, 2016.
 Non-Published U.S. Appl. No. 12/947,695, filed Nov. 16, 2010, titled Edge Lighted Gaming Panels for Electronic Gaming Device.
 Genesis DV1 Cabinets by Cadillac Jack circa 2010, 4 pages.
 Infinity Super Skybox by Incredible Technologies, <https://gaming.itsgames.com/cabinets/infinity-super-skybox>, Aug. 11, 2016.
 Super Sky Wheel Slot Makes World Premiere at Borgata—Borgata Blog, <http://blog.theborgata.com/2016/06/16/super-sky-wheel-slot-makes-world-premiere-at-borgata/>, Jun. 16, 2016.
 Aristocrat Brings the Game Forward With Advanced New Helix Slant Cabinet, Market Wired, <http://www.marketwired.com/press-release/aristocrat-brings-the-game-forward-with-advanced-new-helix-slant-cabinet-asx-all-1904223.htm>, Apr. 29, 2014.
 Helix+ by Aristocrat, 2016.
 Helix Upright by Aristocrat, 2014.
 b.POD by Bluberi, <https://www.bluberi.com/bluberi-bpod/>, Accessed Feb. 27, 2018.
 Bluberi Set to Reveal Dramatic New Product Line-Up at G2E 2017, Press Release, Soloazar, <http://www.soloazar.com/international/noticia/19870-Bluberi-Set-to-Reveal-Dramatic-New-Product-Line-Up-at-G2E-2017>, Sep. 15, 2017.
 AGS LLC; Exhibit 22 to Response to Office Action dated Jul. 27, 2018 with the U.S. Patent and Trademark Office in U.S. Trademark Application Serial No. 87/620,830; 24 pages.

* cited by examiner

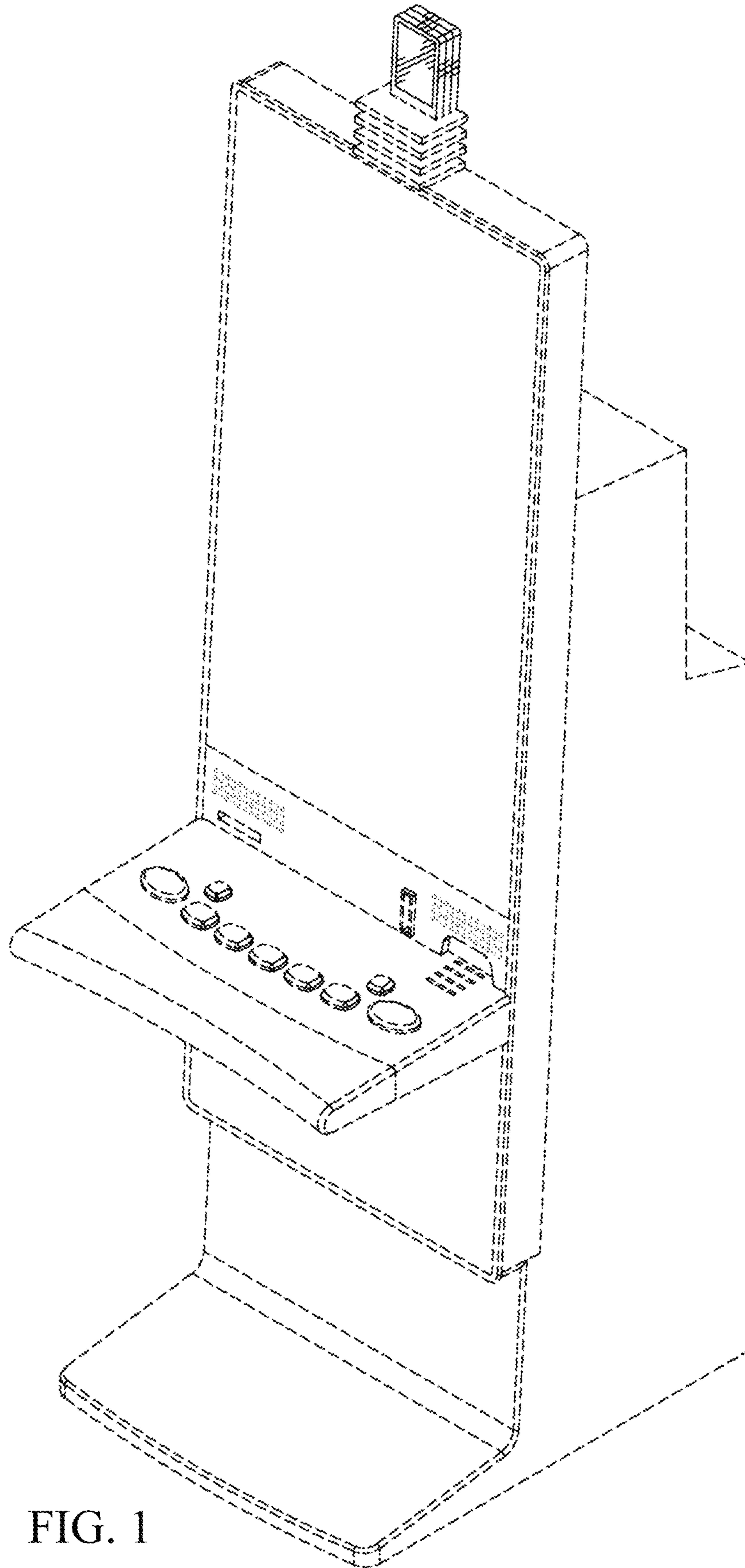

FIG. 1

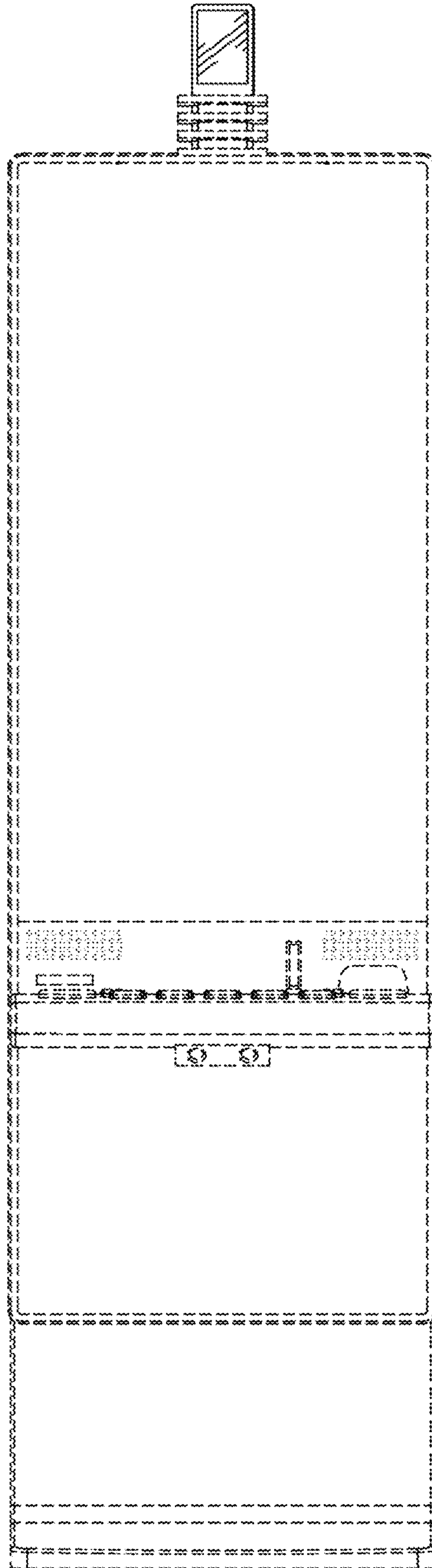

FIG. 2

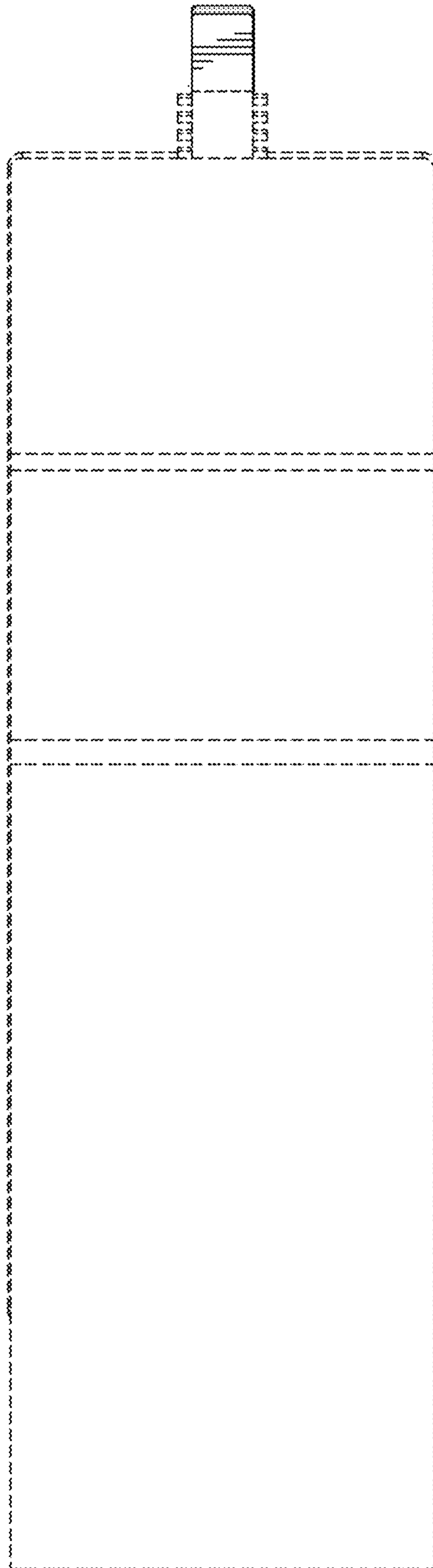

FIG. 3

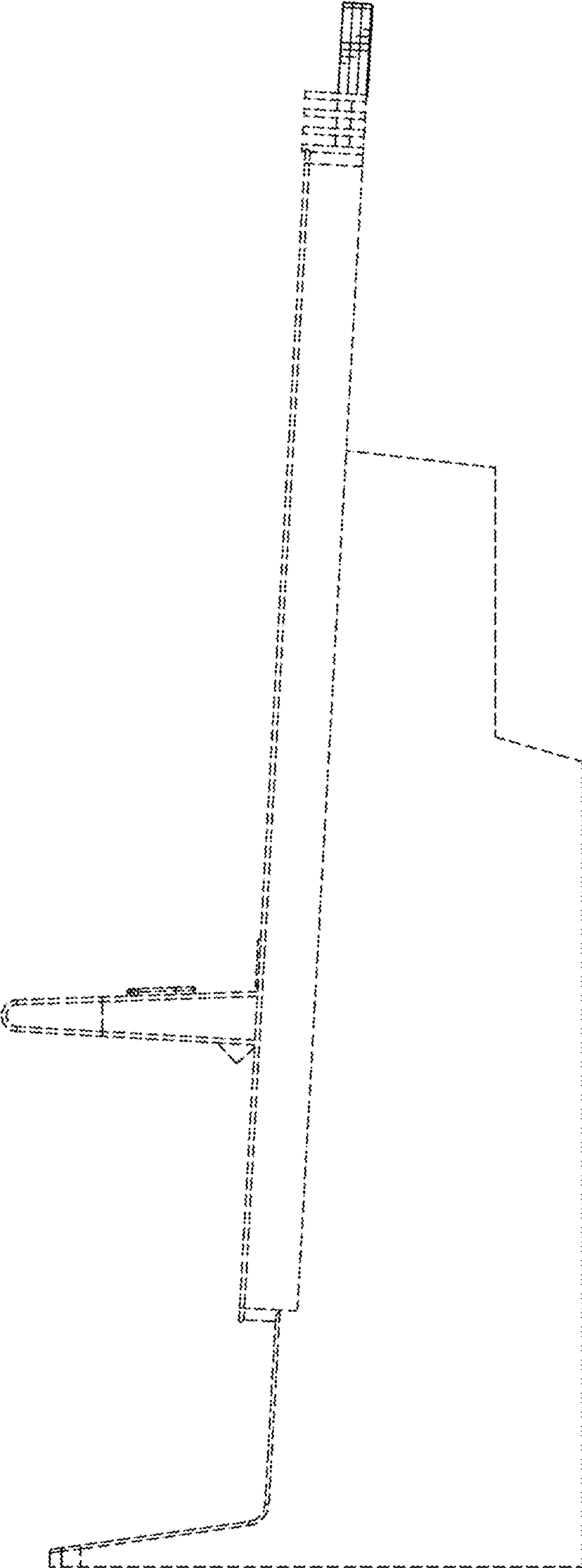

FIG. 4

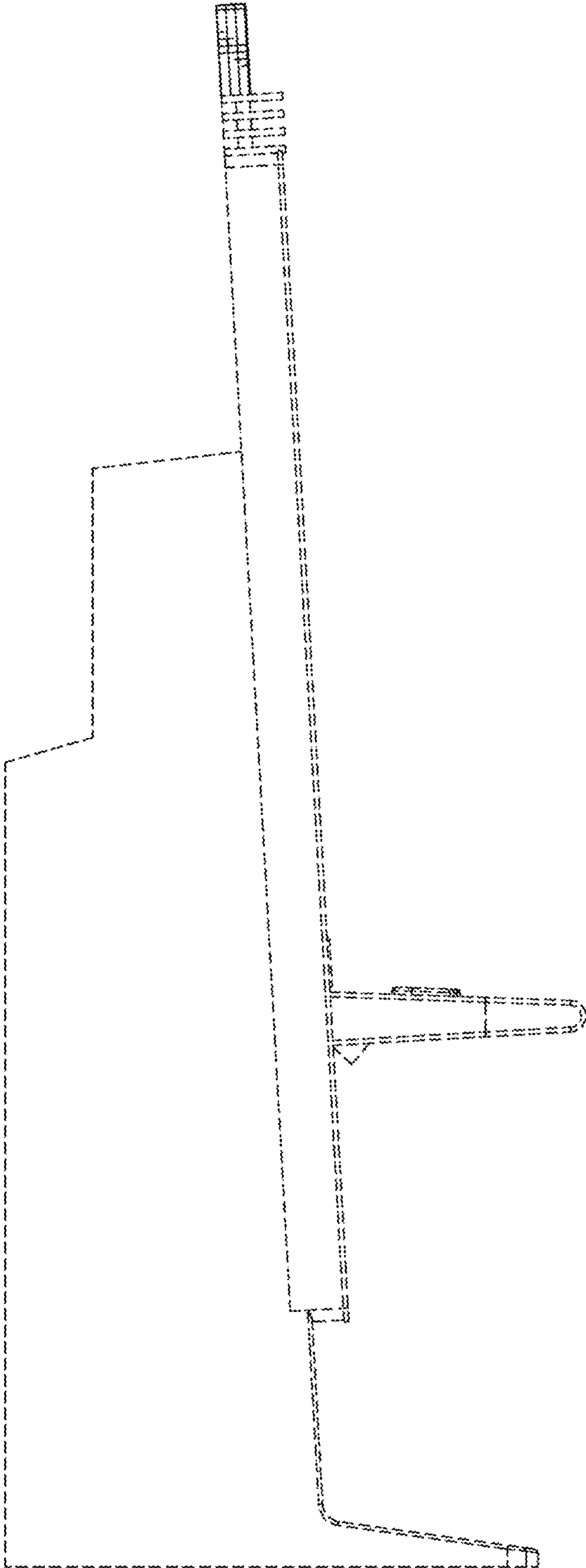

FIG. 5

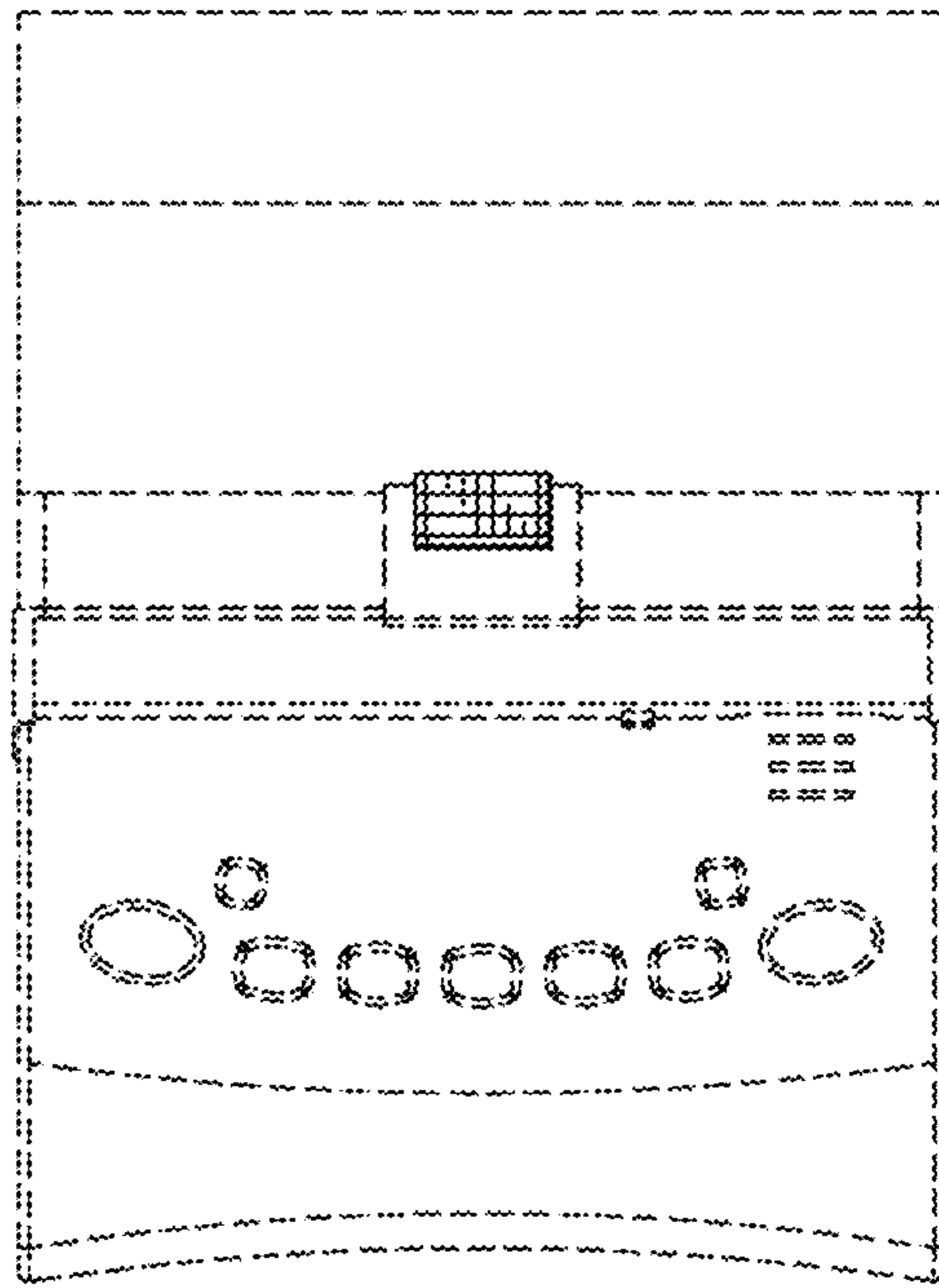

FIG. 6

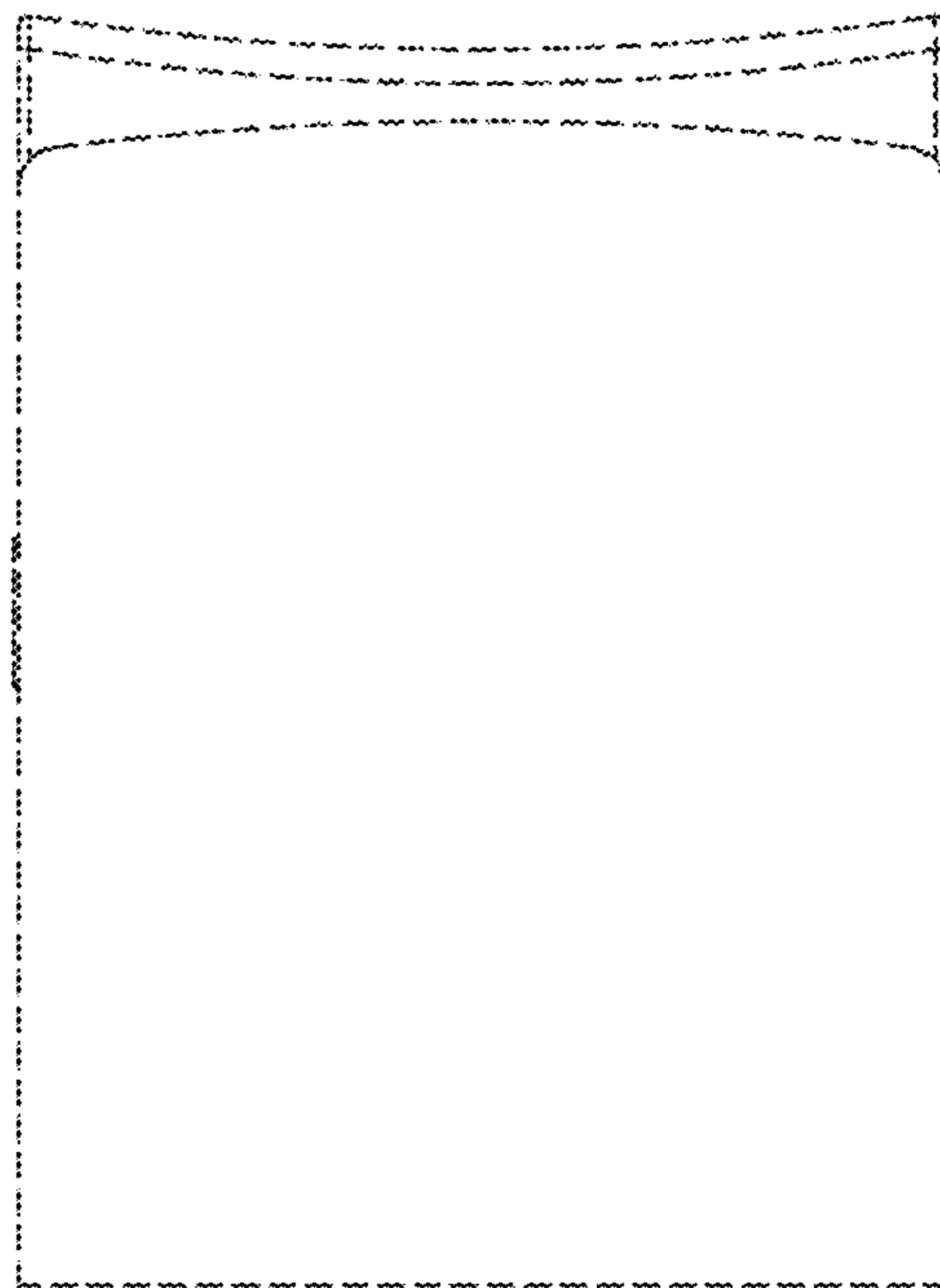

FIG. 7