



US00D889376S

(12) **United States Design Patent** (10) **Patent No.:** **US D889,376 S**
Prasad et al. (45) **Date of Patent:** **** Jul. 7, 2020**

(54) **WHEEL FLANGE**

FOREIGN PATENT DOCUMENTS

(71) Applicant: **ARCONIC INC.**, Pittsburgh, PA (US)

AU 351933 11/2013
AU 351934 11/2013

(72) Inventors: **Santosh Prasad**, Murrysville, PA (US);
James T. Burg, Verona, PA (US);
Gabriele F. Ciccola, Hudson, OH (US);
Michael A. Pacek, Freeport, PA (US);
Erin Fulton, Irwin, PA (US); **Anton J. Rovito**, Parma, OH (US); **Jason C Lee**, Pittsburgh, PA (US); **Michael A Globig**, New Kensington, PA (US)

(Continued)

OTHER PUBLICATIONS

Wheel at <http://www.ntda.org/ntda/News/tabid/59/post/east-announces-alcoa-s-ultra-one-wheel-as-standard-on-all-east-trailers/Default.aspx>, published on Feb. 4, 2014.

(Continued)

(73) Assignee: **Howmet Aerospace Inc.**, Pittsburgh, PA (US)

Primary Examiner — Stacia A Cadmus

(74) *Attorney, Agent, or Firm* — Greenberg Traurig, LLP

(**) Term: **15 Years**

(57) **CLAIM**

(21) Appl. No.: **29/631,444**

The ornamental design for a wheel flange, as shown and described.

(22) Filed: **Dec. 29, 2017**

DESCRIPTION

(51) **LOC (12) Cl.** **12-16**

(52) **U.S. Cl.**

USPC **D12/213**

(58) **Field of Classification Search**

USPC D12/204–213

CPC B60B 7/00; B60B 7/02; B60B 7/04; B60B 7/01; B60B 7/06; B60B 3/02; B60B 3/04; B60B 3/06; B60B 3/10; B60B 1/00; B60B 1/08; B60B 1/10; B60B 1/12

See application file for complete search history.

FIG. 1 is a front perspective view of a wheel flange showing our new design;

FIG. 2 is a rear perspective view thereof;

FIG. 3 is a front view thereof;

FIG. 4 is a rear view thereof;

FIG. 5 is a side view thereof;

FIG. 6 is a top view thereof;

FIG. 7 is a bottom view thereof;

FIG. 8 is a cross-sectional view thereof taken along line 8-8 in FIG. 5;

FIG. 9 is a cross-sectional view thereof taken along line 9-9 in FIG. 6;

FIG. 10 is an enlarged view of a portion of the wheel flange indicated by area 10 in FIG. 1; and,

FIG. 11 is an enlarged view of a portion of the wheel flange indicated by area 11 in FIG. 2.

In the drawings the broken lines depict environmental subject matter and form no part of the claimed design.

(56) **References Cited**

U.S. PATENT DOCUMENTS

3,302,275 A 2/1967 Turpin
D284,753 S 7/1986 Hedlund
D327,466 S 6/1992 Lipper
D358,797 S 5/1995 Botterman
D492,923 S 7/2004 Whitehead
D504,378 S 4/2005 Grossenbacher et al.

(Continued)

1 Claim, 11 Drawing Sheets

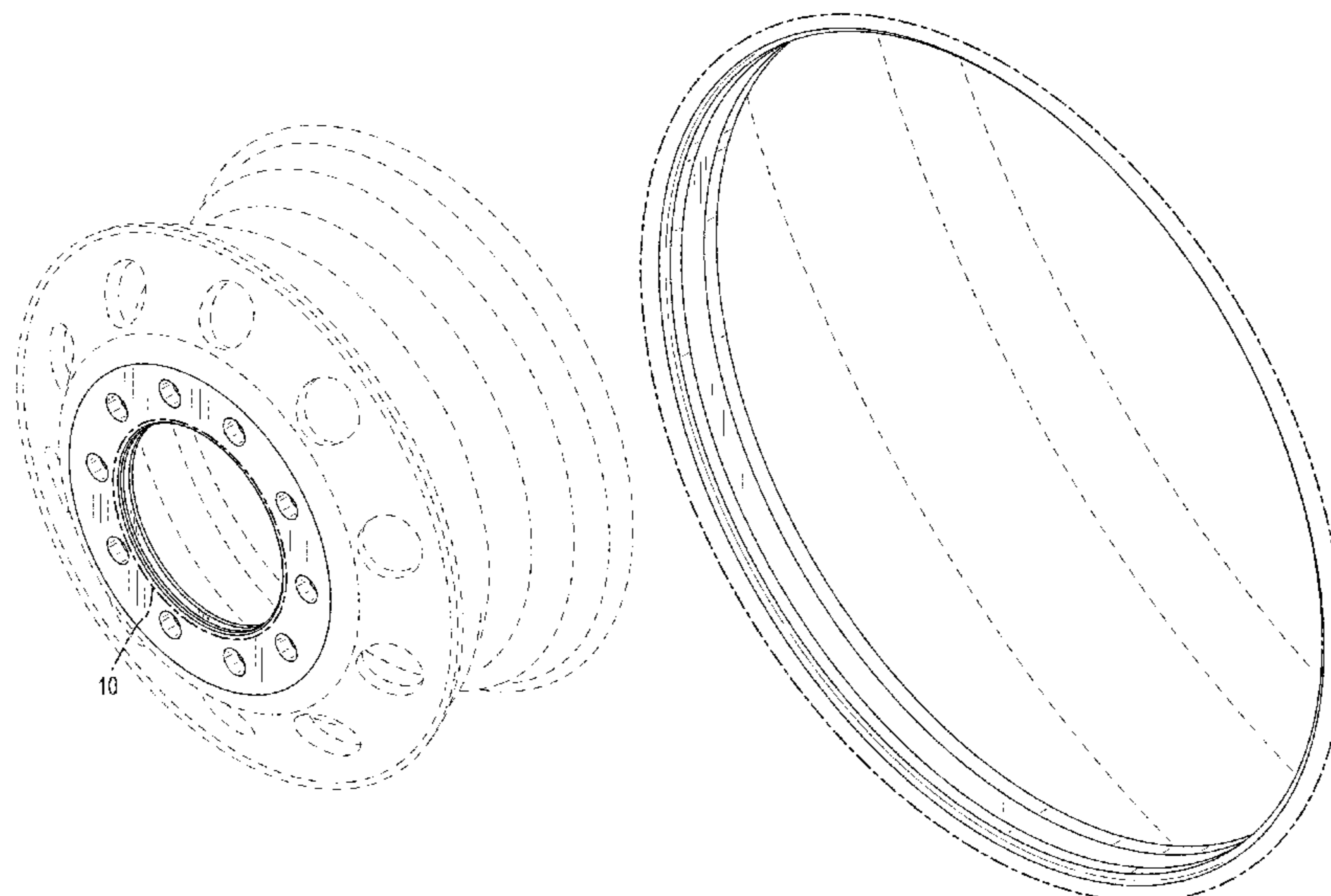

(56)

References Cited

U.S. PATENT DOCUMENTS

D519,433 S 4/2006 Finn
D527,324 S 8/2006 Whitehead
D598,835 S 8/2009 DeGeorge
9,032,600 B2 5/2015 Pulphus
D773,974 S 12/2016 DeGeorge et al.
9,604,498 B2* 3/2017 Zehnder B60B 3/02
D811,977 S * 3/2018 Ocroft D12/210
D829,152 S * 9/2018 Caldwell D12/209
D836,057 S * 12/2018 Prasad D12/209
D836,522 S * 12/2018 Prasad D12/209
D837,120 S * 1/2019 Caldwell D12/209

FOREIGN PATENT DOCUMENTS

CA 104173 1/2005
CA 167267 2/2017
CN 304095164 S 4/2017

EM 002089565-0001 10/2012
JP 2009-051248 3/2009
JP 1540615 12/2015

OTHER PUBLICATIONS

Wheel at <https://worldindustrialreporter.com/alcoa-develops-new-dura-bright-evo-wheel-with-enhanced-durability-and-easy-maintenance/>, published on Jan. 27, 2014.
Wheel at <http://www.moderntiredealer.com/news/399994/accuride-wheels-aim-to-reduce-flange-wear>, published on Jun. 9, 2014.
Commonly owned Design U.S. Appl. No. 29/631,442, filed Dec. 29, 2017, entitled "Wheel Having Internal Scalloped Groove".
Commonly owned Design U.S. Appl. No. 29/631,455, filed Dec. 29, 2017 entitled "Ribbed Wheel".
Commonly owned Design U.S. Appl. No. 29/631,467, filed Dec. 29, 2017, entitled "Ribbed Wheel".
Commonly owned Design U.S. Appl. No. 29/631,449, filed Dec. 29, 2017, entitled "Ribbed Wheel".

* cited by examiner

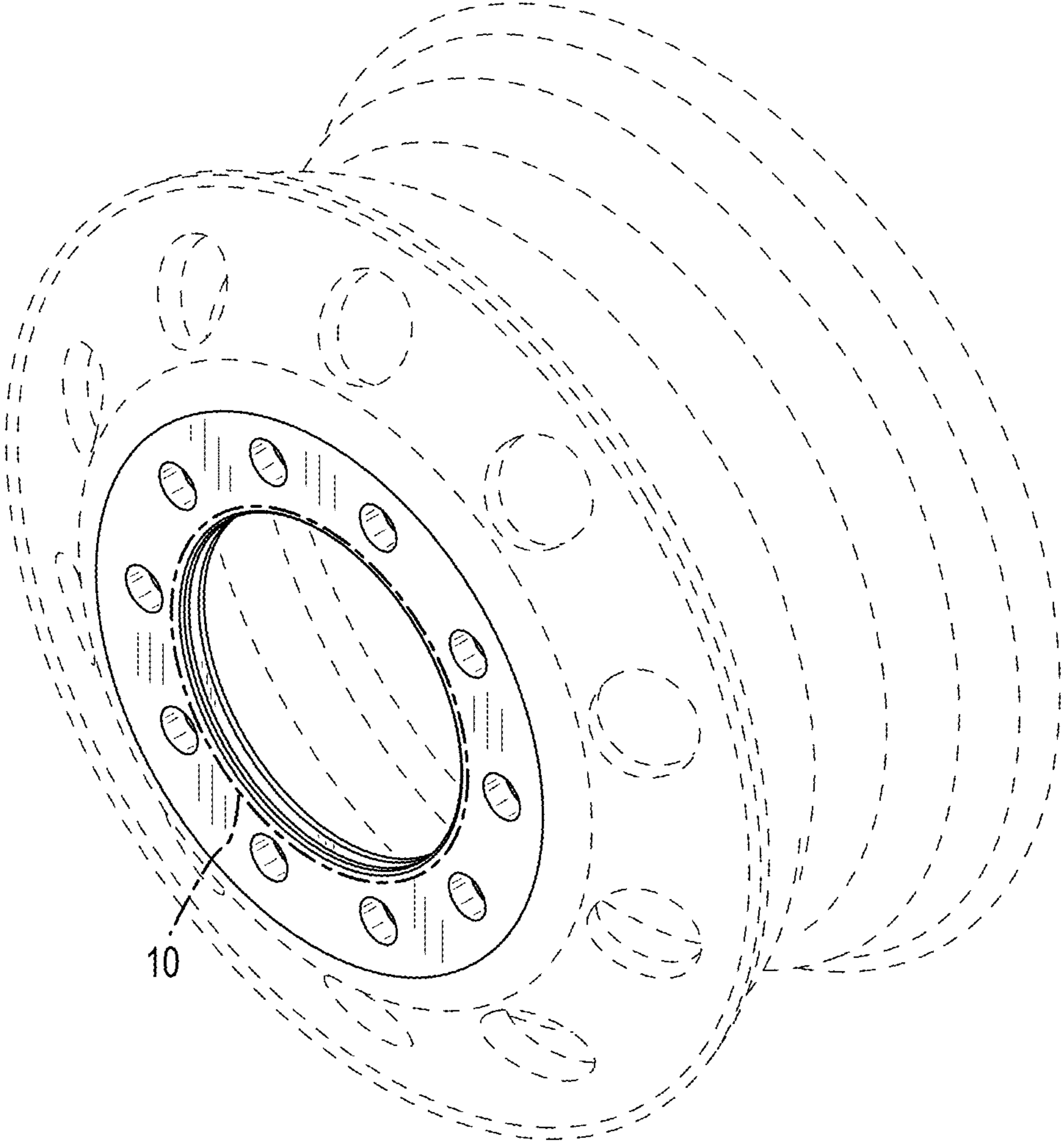

FIG.1

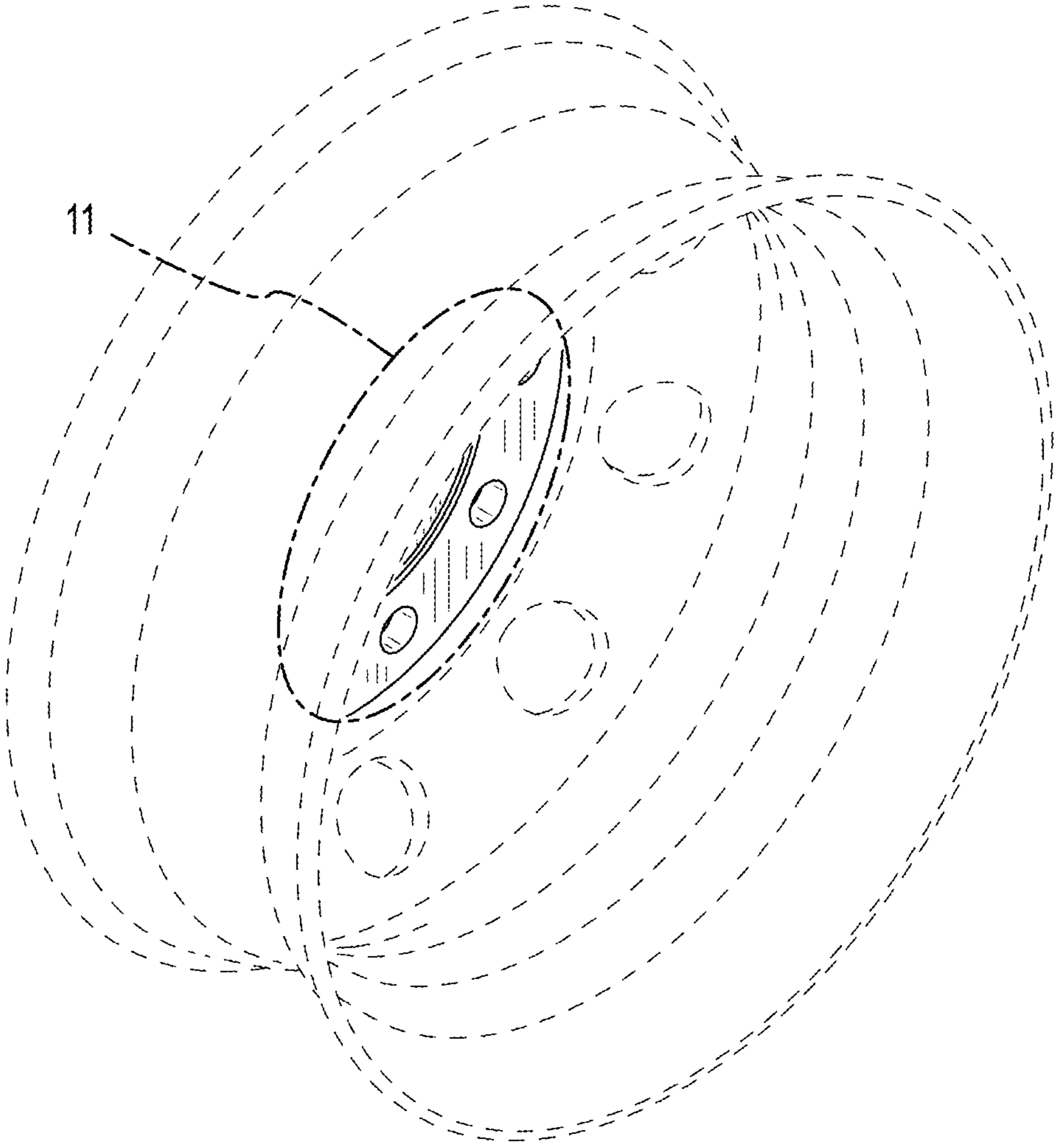

FIG.2

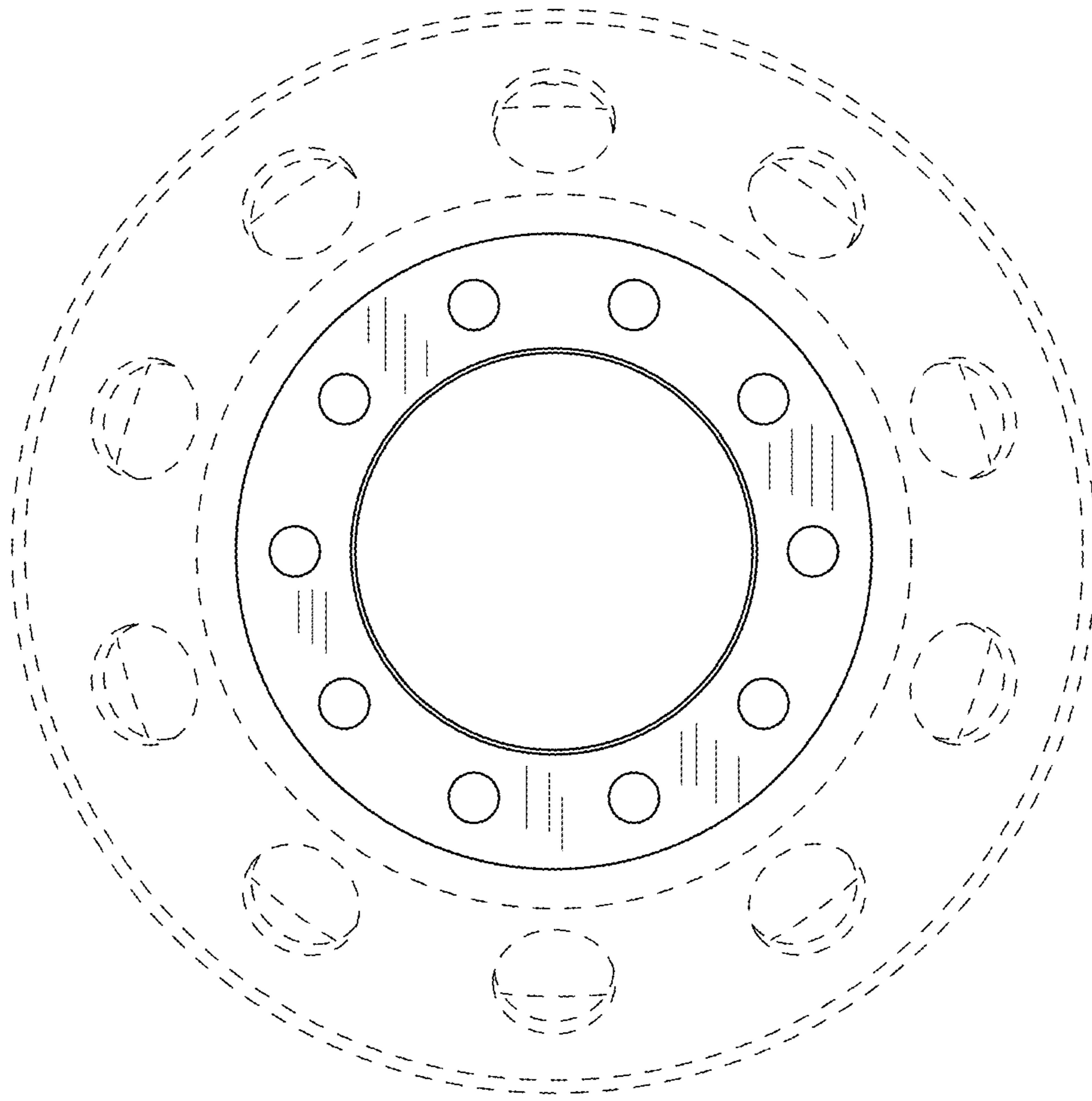

FIG.3

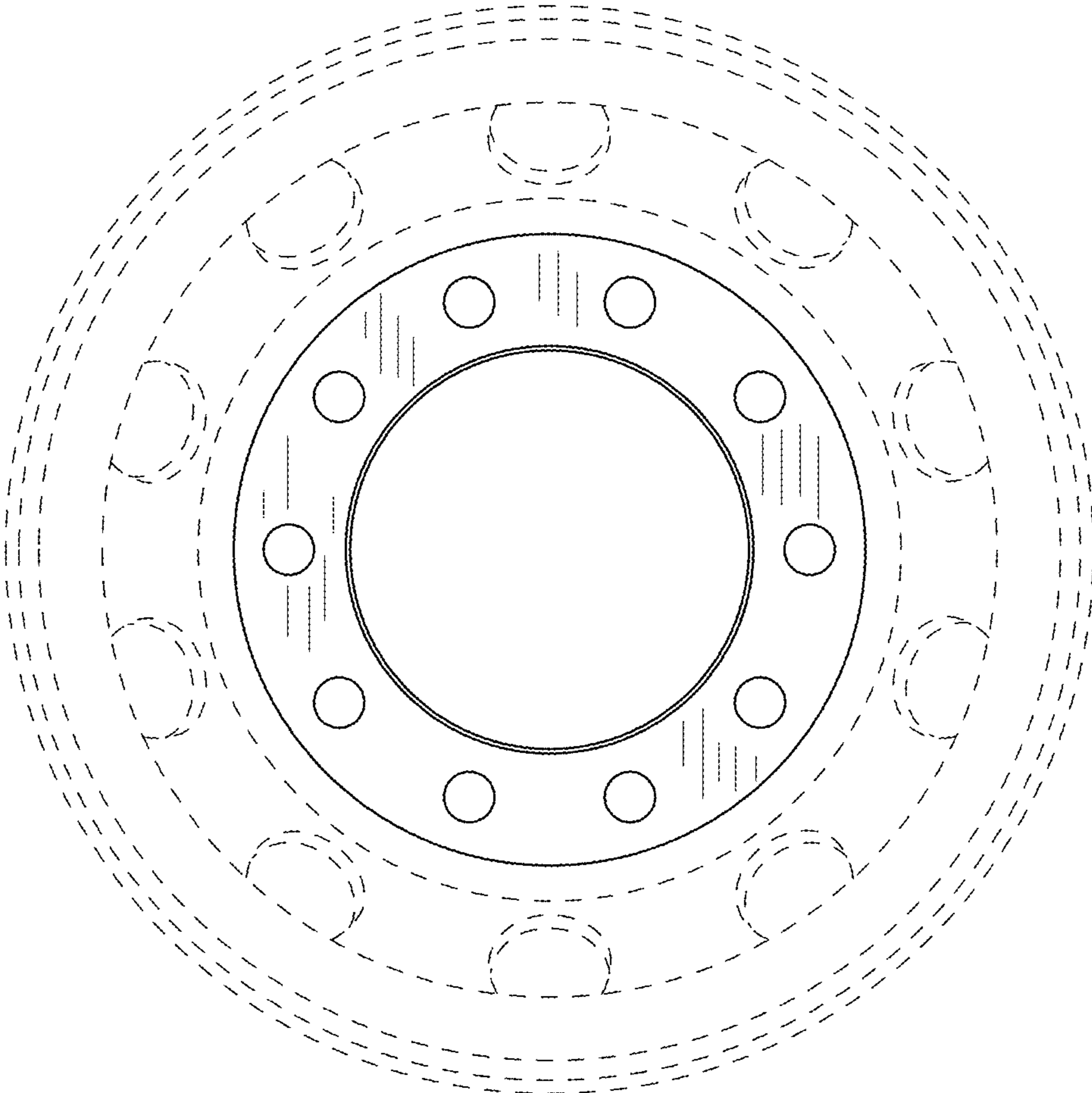

FIG.4

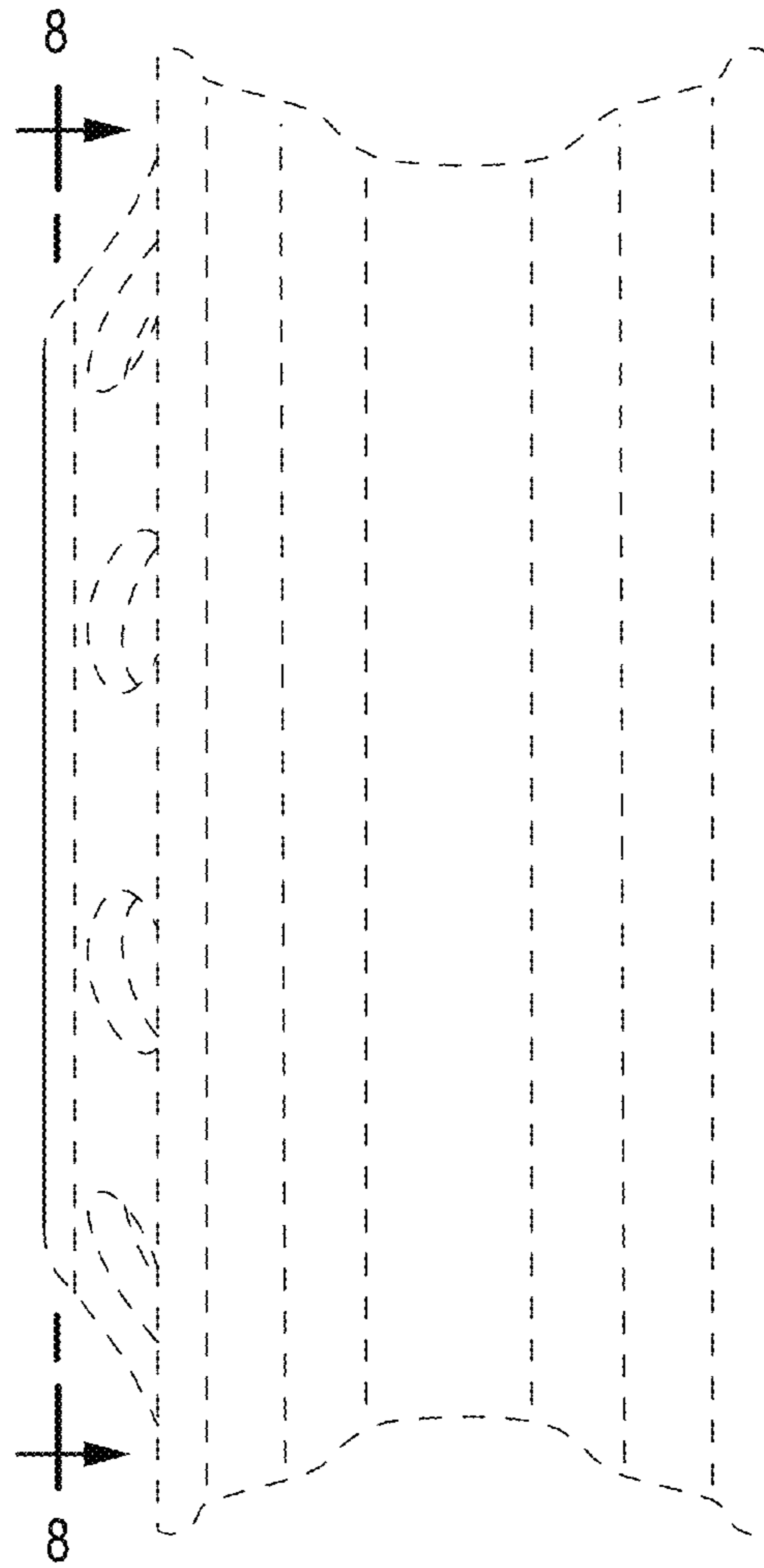

FIG.5

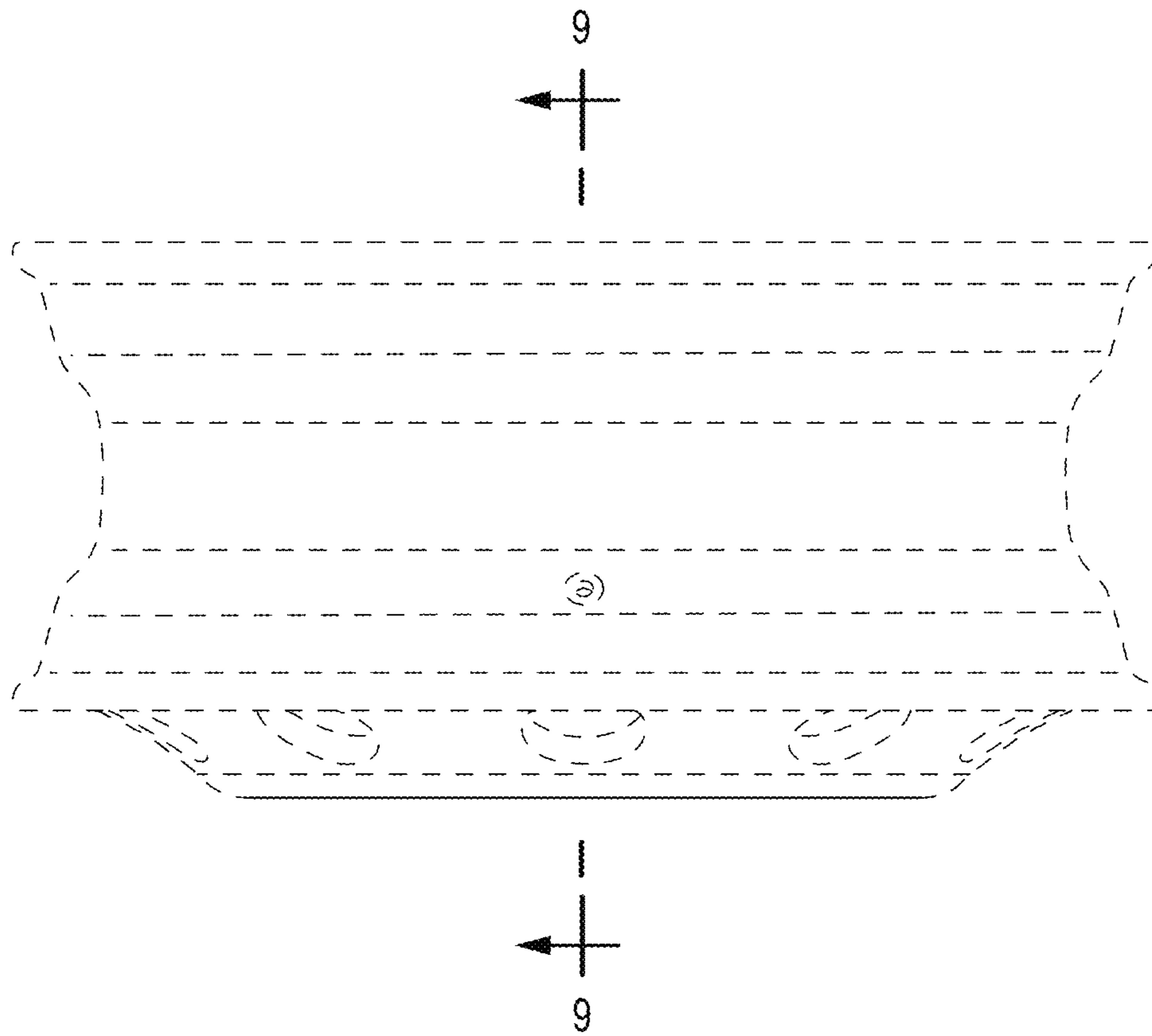

FIG.6

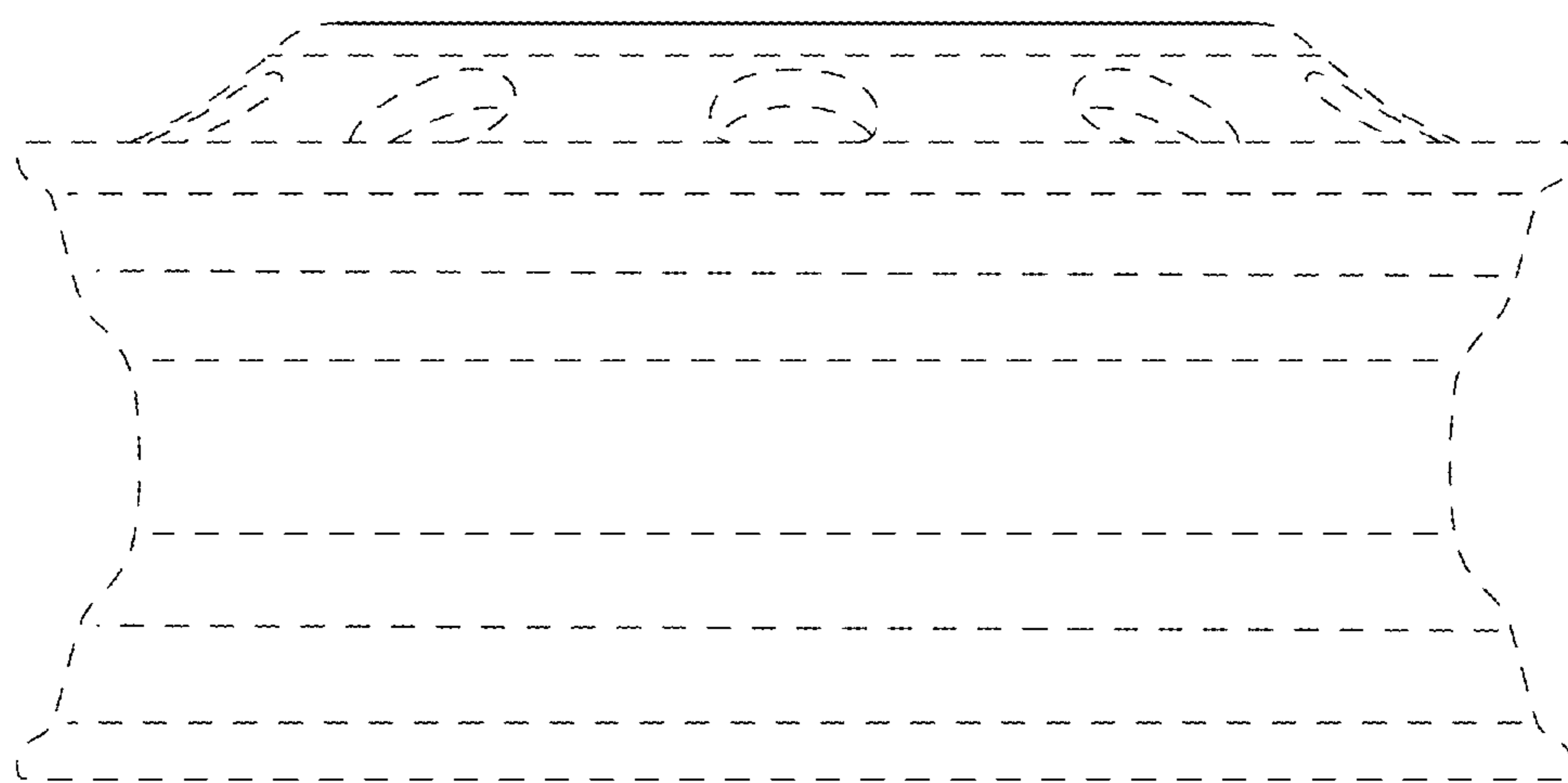

FIG.7

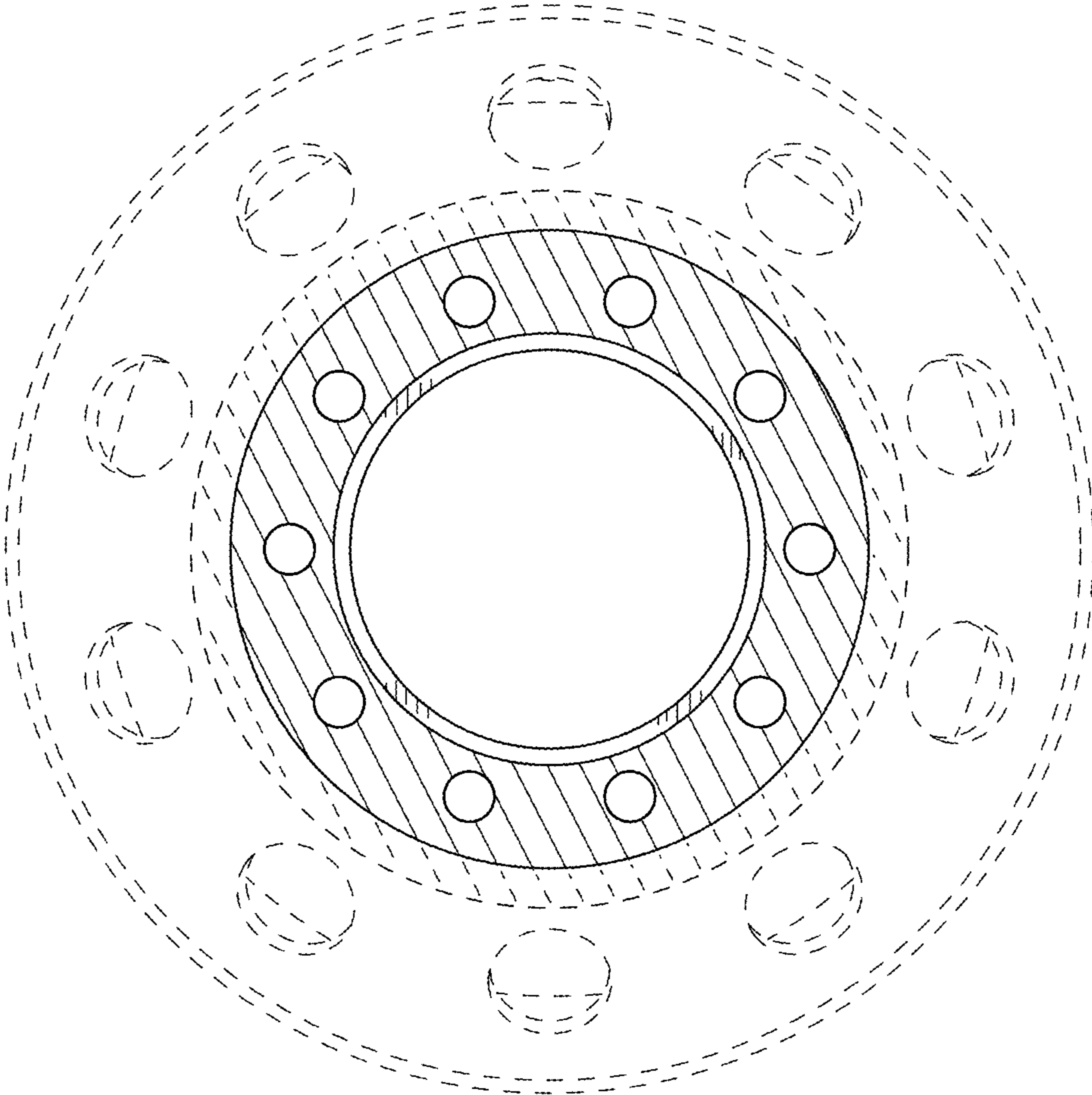

FIG.8

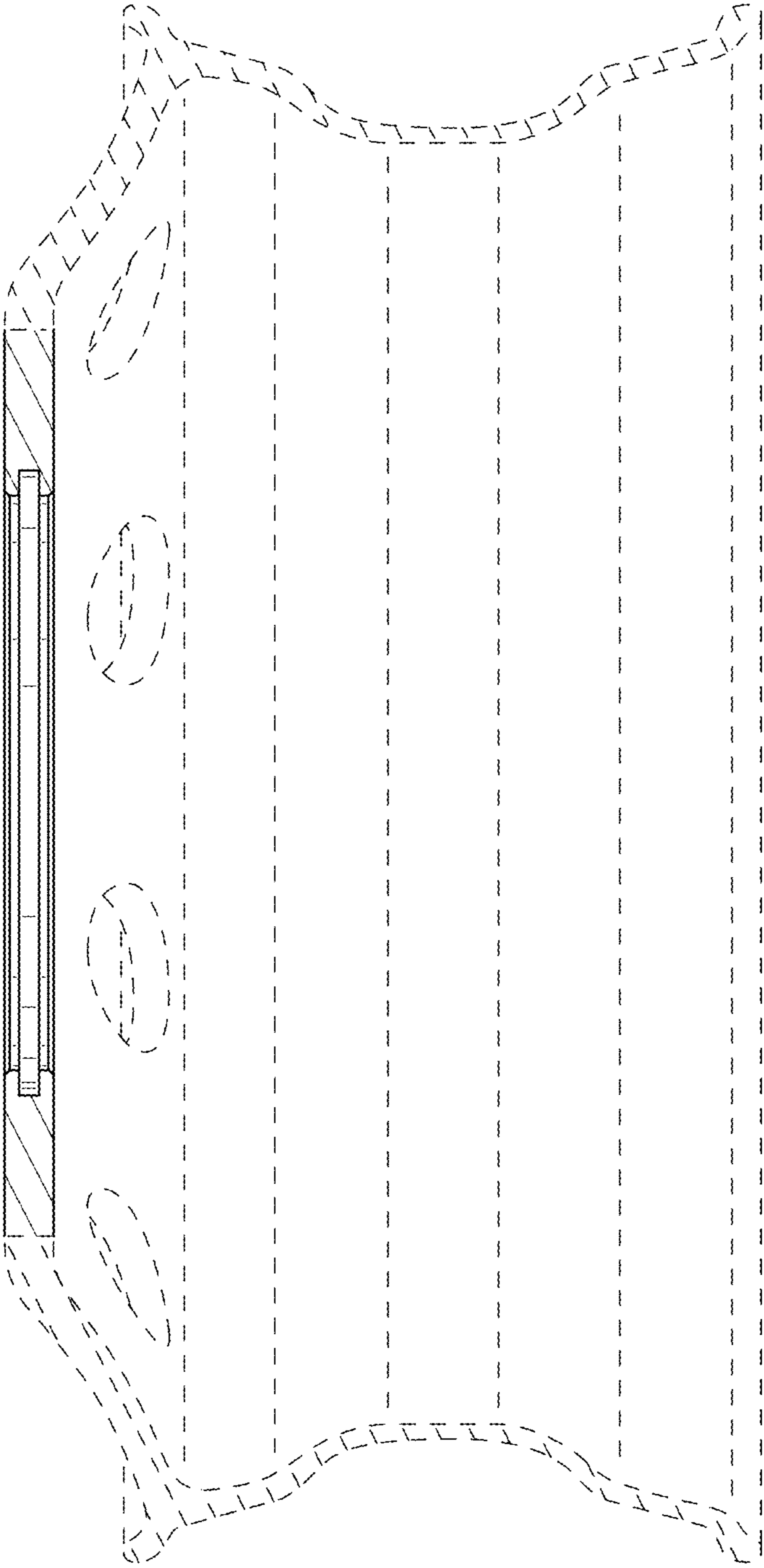

FIG.9

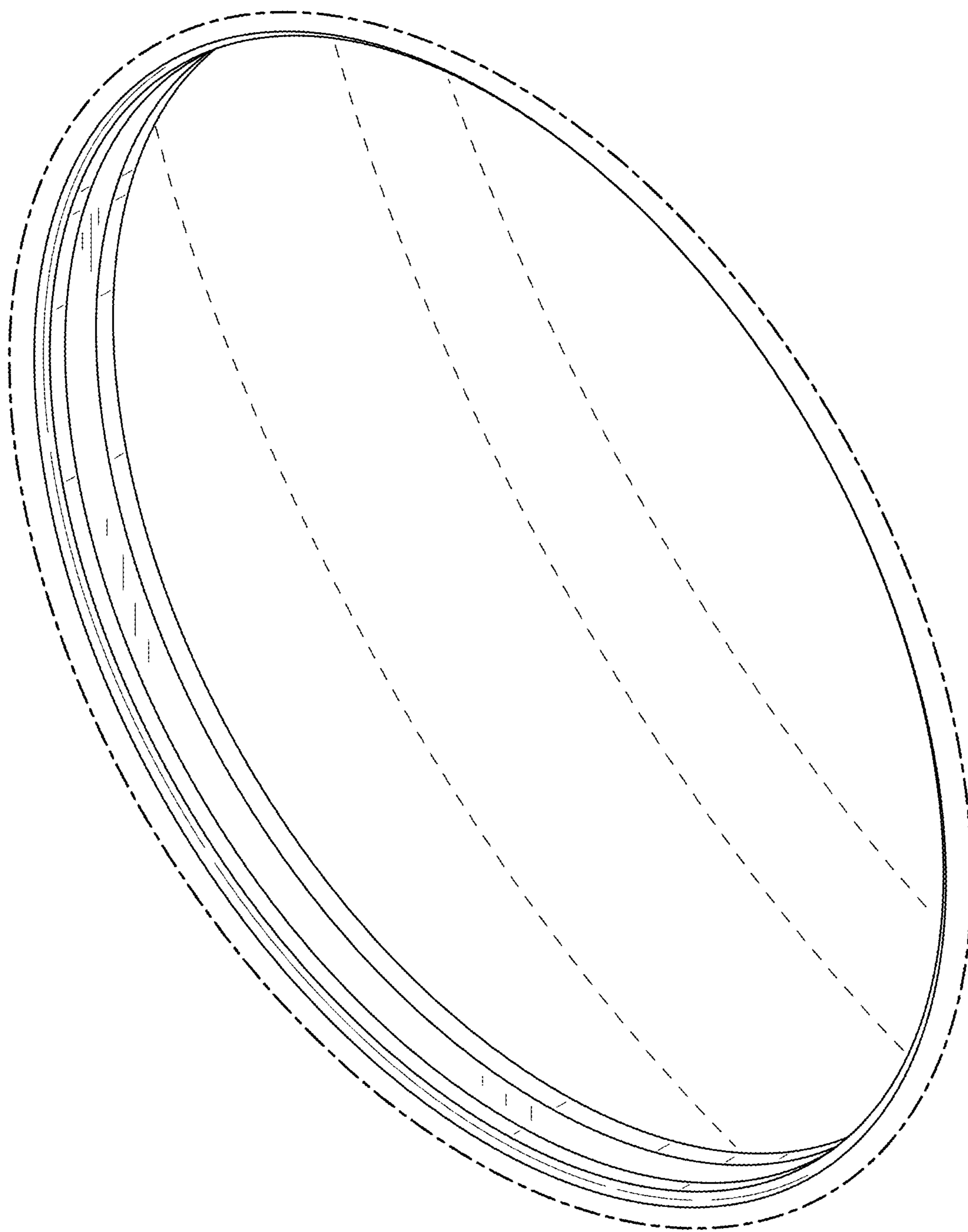

FIG.10

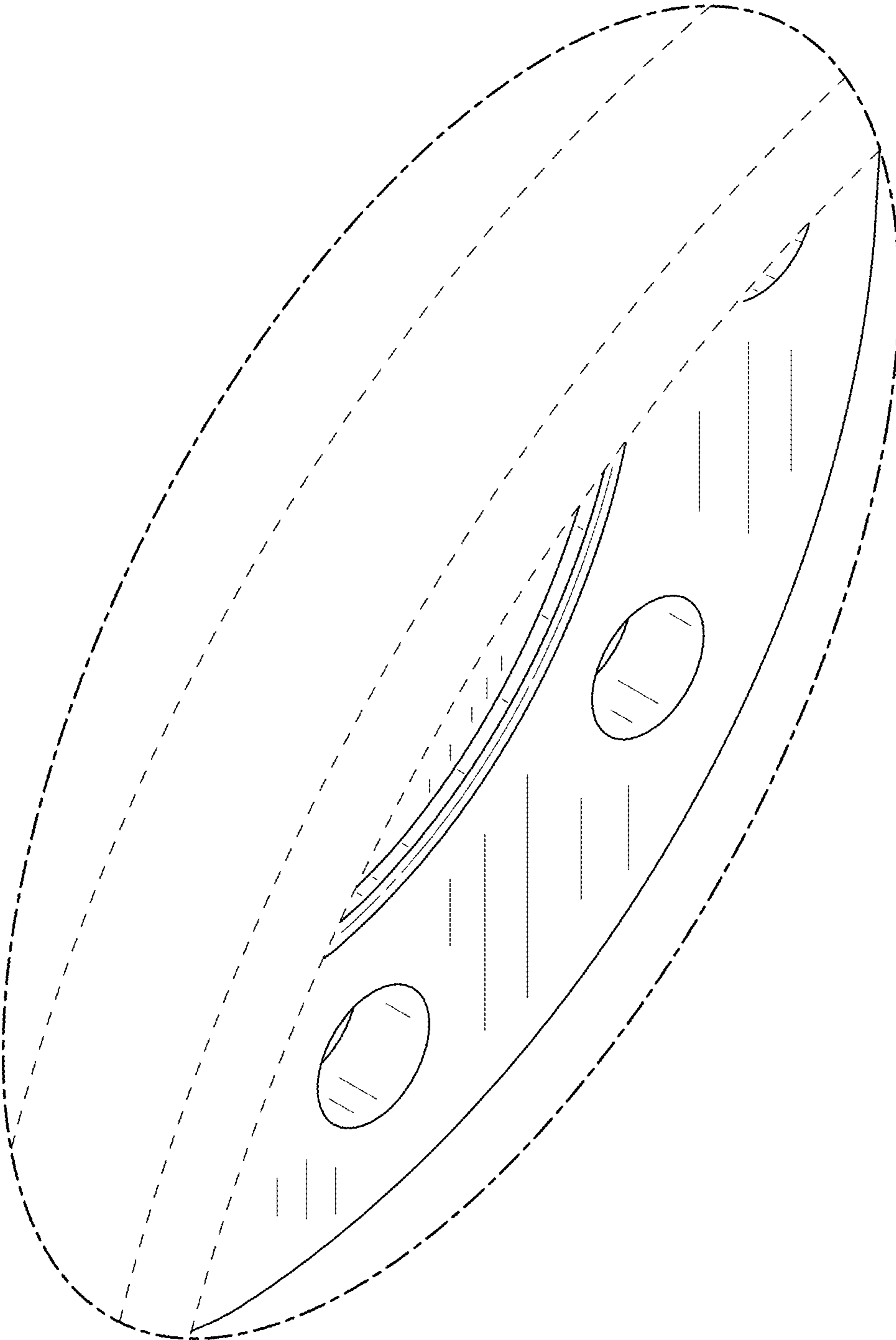

FIG.11