



US00D889360S

(12) **United States Design Patent**
Ninov et al.

(10) **Patent No.:** **US D889,360 S**
(45) **Date of Patent:** **** Jul. 7, 2020**

(54) **WHEEL**

(71) Applicants: **Deyan Ninov**, Royal Oak, MI (US);
Gregory A. Howell, Farmington, MI (US)

(72) Inventors: **Deyan Ninov**, Royal Oak, MI (US);
Gregory A. Howell, Farmington, MI (US)

(73) Assignee: **FCA US LLC**, Auburn Hills, MI (US)

(**) Term: **15 Years**

(21) Appl. No.: **29/680,058**

(22) Filed: **Feb. 13, 2019**

(51) **LOC (12) Cl.** **12-16**

(52) **U.S. Cl.**
USPC **D12/209**

(58) **Field of Classification Search**
USPC D12/204–213; D21/563
CPC B60B 7/00; B60B 7/02; B60B 7/04; B60B 7/01;
B60B 7/06; B60B 3/02; B60B 3/04; B60B 3/06;
B60B 3/10; B60B 1/00; B60B 1/08; B60B 1/10; B60B 1/12
See application file for complete search history.

(56) **References Cited**

U.S. PATENT DOCUMENTS

D453,492 S * 2/2002 Laengerer D12/209
D491,873 S * 6/2004 Markefka D12/211

D495,649 S * 9/2004 Schell D12/209
D526,265 S * 8/2006 Muzzarelli D12/209
D551,146 S * 9/2007 Hueller D12/209
D580,335 S * 11/2008 Choi D12/211
D581,338 S * 11/2008 Imai D12/209
D613,228 S * 4/2010 Juergens D12/209
D614,110 S * 4/2010 Tant D12/211
D617,710 S * 6/2010 Ectors D12/209
D620,420 S * 7/2010 Lamm D12/209
D625,240 S * 10/2010 George D12/211
D700,122 S * 2/2014 Campbell D12/204
D709,426 S * 7/2014 Kong D12/209
D712,330 S * 9/2014 Chung D12/209
D783,490 S * 4/2017 Bucher D12/209
D787,406 S * 5/2017 Piscitelli D12/209
D865,612 S * 11/2019 Interrante D12/209

* cited by examiner

Primary Examiner — Stacia A Cadmus

(74) *Attorney, Agent, or Firm* — Ralph E. Smith

(57) **CLAIM**

The ornamental design for a wheel, as shown and described.

DESCRIPTION

FIG. 1 is a left perspective view of a wheel showing our new design;
FIG. 2 is a right perspective view thereof; and,
FIG. 3 is a front view thereof.
It will be understood that the broken lines shown in the drawings illustrate portions of the wheel that form no part of the claimed design.

1 Claim, 3 Drawing Sheets

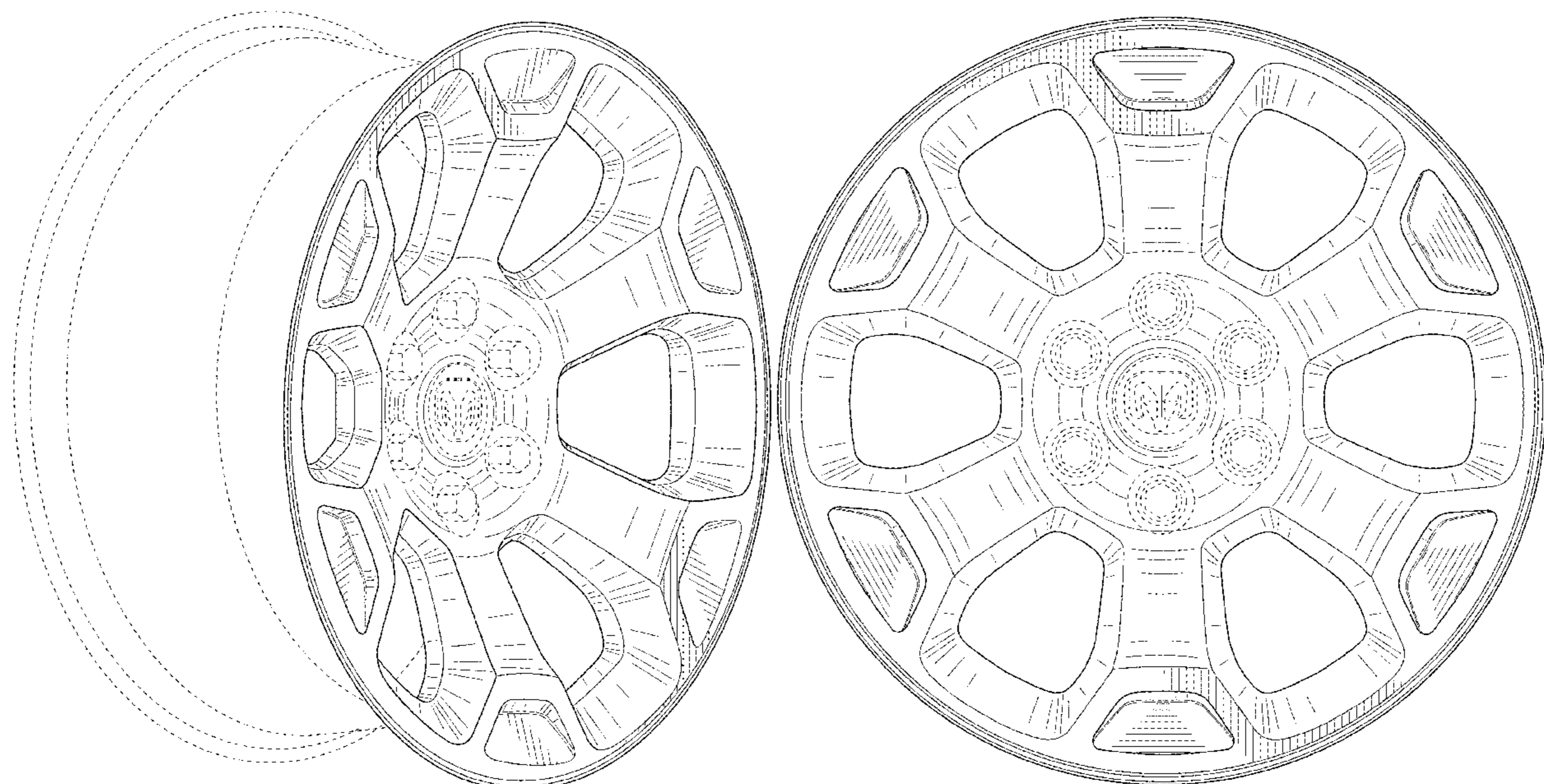

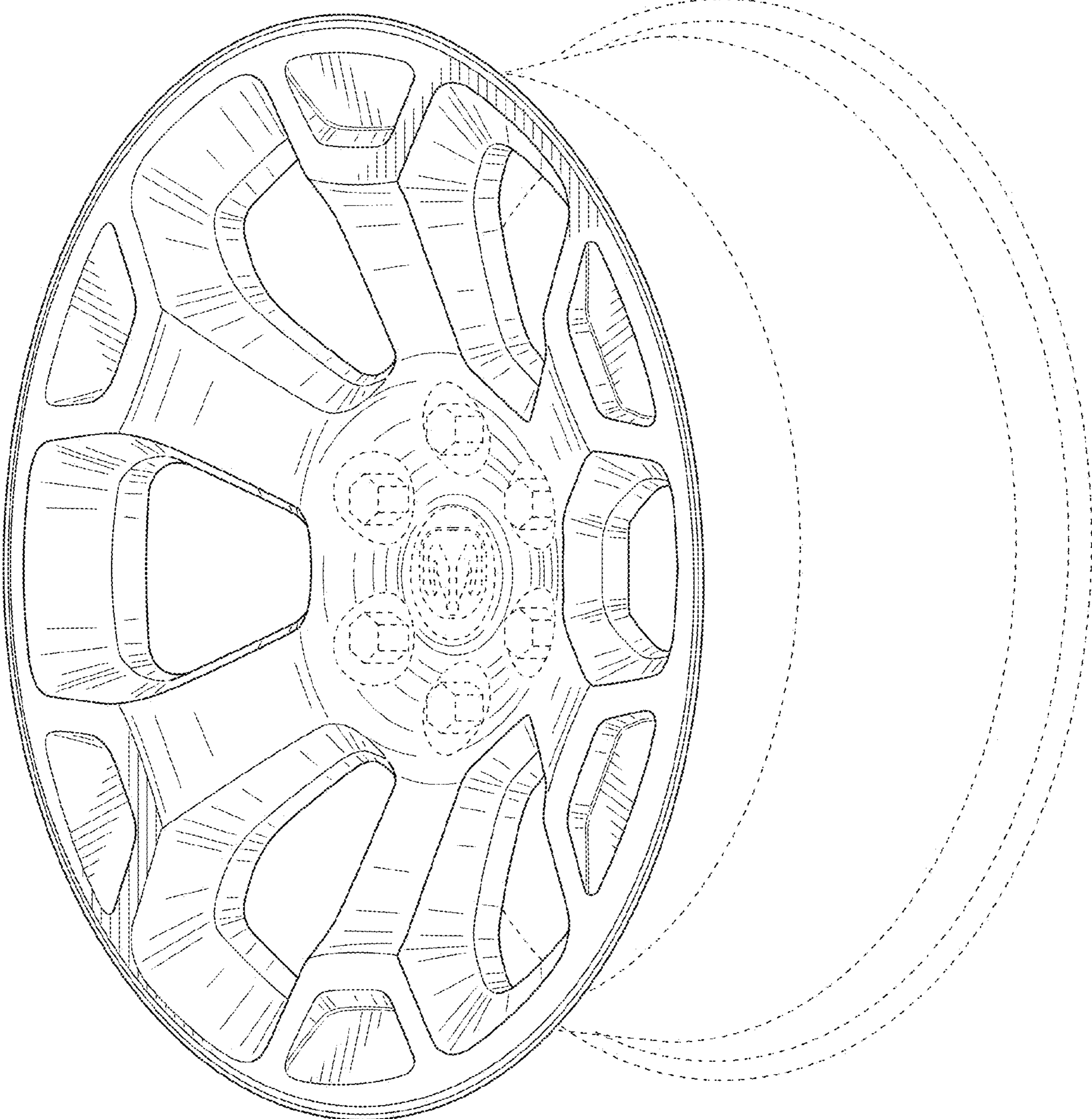

FIG. 1

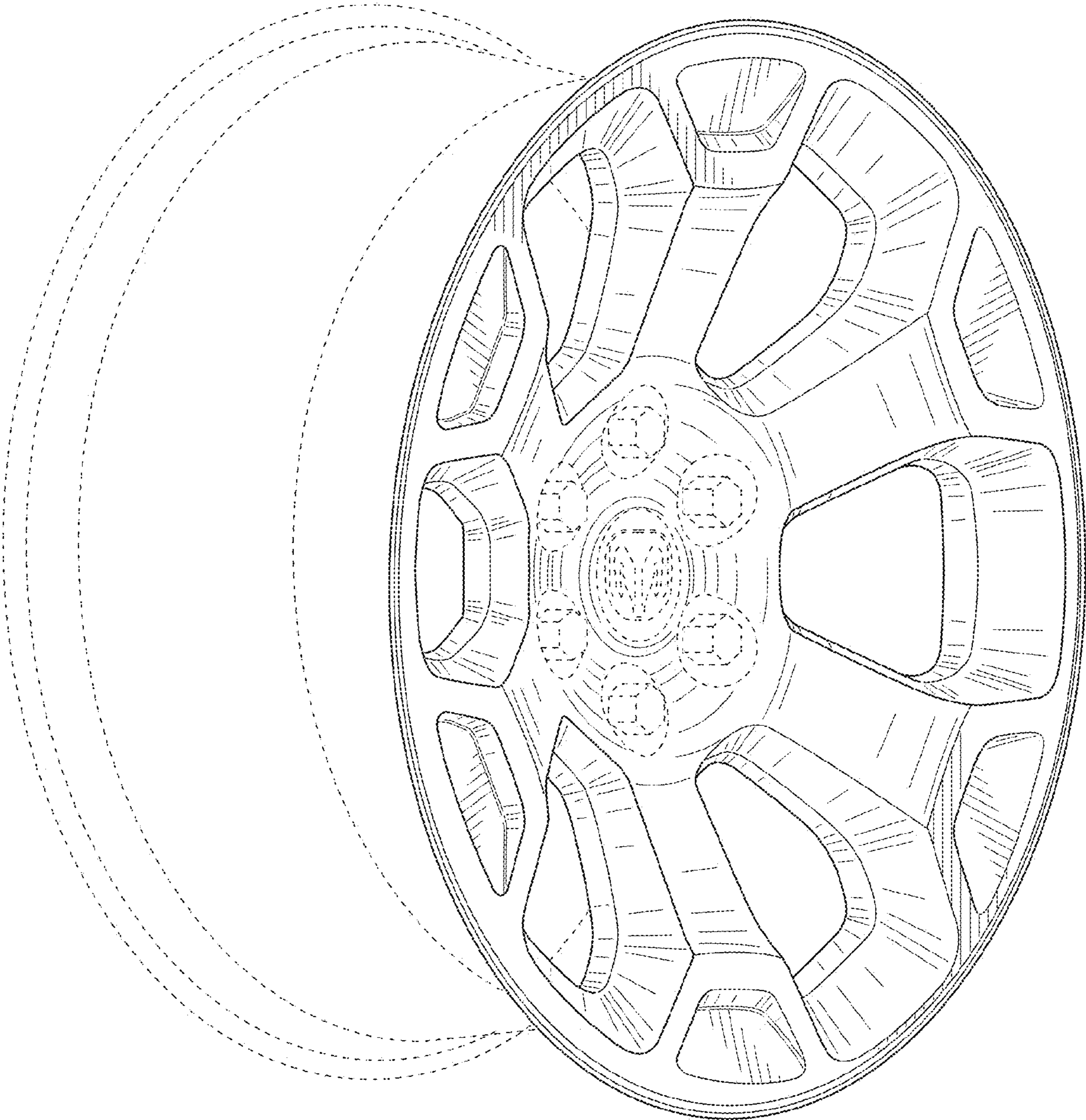

FIG. 2

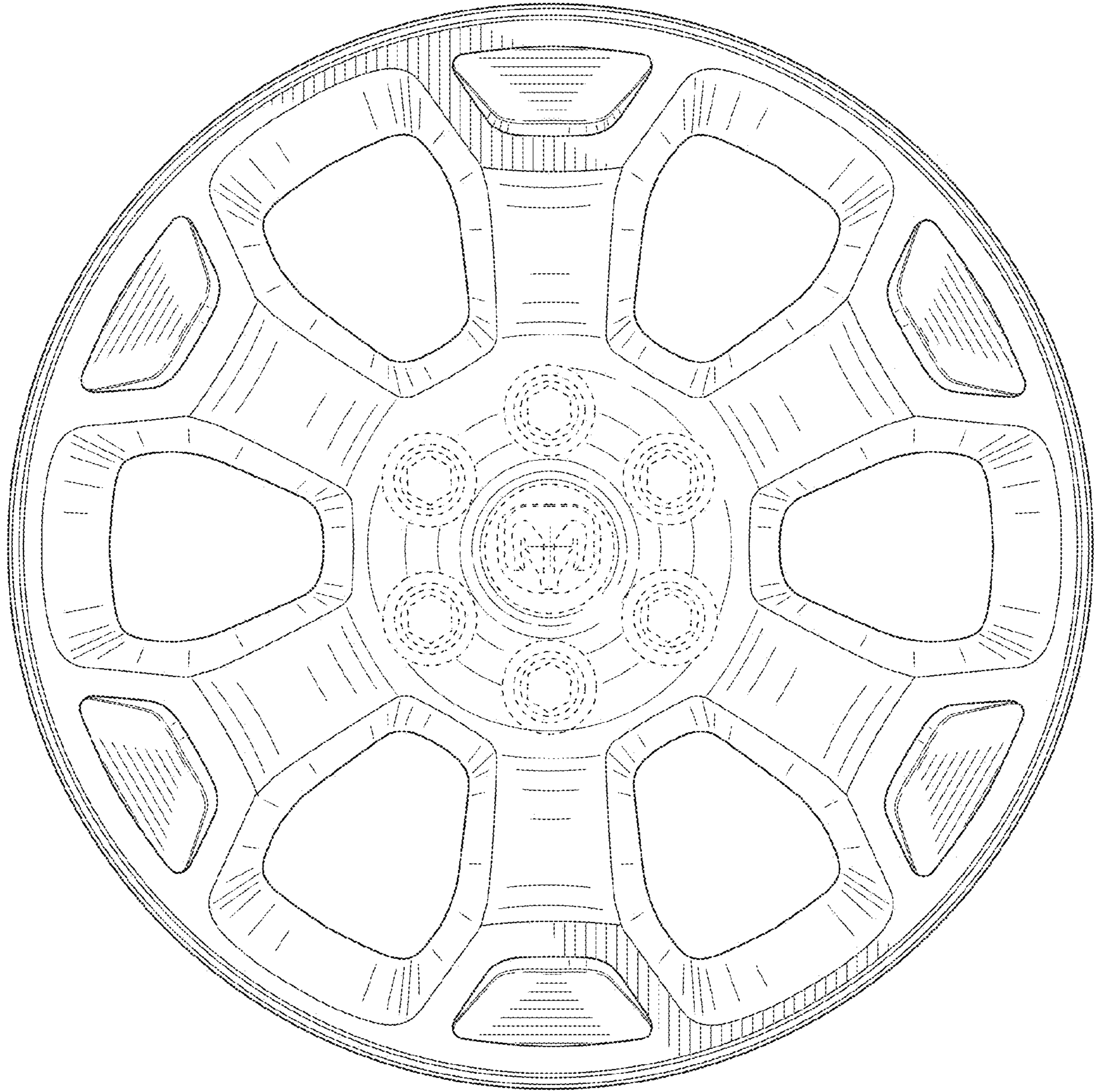

FIG. 3