



US00D889347S

(12) **United States Design Patent**
Smith

(10) **Patent No.:** **US D889,347 S**

(45) **Date of Patent:** **** Jul. 7, 2020**

(54) **WHEEL**

(71) Applicant: **Jaguar Land Rover Limited**, Whitley,
Coventry (GB)

(72) Inventor: **Luke Smith**, Coventry (GB)

(73) Assignee: **Jaguar Land Rover Limited**, Whitley,
Coventry (GB)

(*) Notice: This patent is subject to a terminal dis-
claimer.

(**) Term: **15 Years**

(21) Appl. No.: **29/635,907**

(22) Filed: **Feb. 5, 2018**

(30) **Foreign Application Priority Data**

Aug. 22, 2017 (EM) 004159150

(51) **LOC (12) Cl.** **12-16**

(52) **U.S. Cl.**
USPC **D12/209**

(58) **Field of Classification Search**
USPC D12/204–213
CPC B60B 7/00; B60B 7/02; B60B 7/04; B60B
7/01; B60B 7/06; B60B 3/02; B60B 3/04;
B60B 3/06; B60B 3/10; B60B 1/00;
B60B 1/08; B60B 1/10; B60B 1/12
See application file for complete search history.

(56) **References Cited**

U.S. PATENT DOCUMENTS

D581,853 S * 12/2008 Rak D12/211
D590,757 S * 4/2009 Froehlich D12/209
D626,052 S * 10/2010 Majdandzic D12/209
D656,443 S * 3/2012 Fetherston D12/209

D753,043 S * 4/2016 Pollmann D12/209
D766,153 S * 9/2016 Wheel D12/209
D793,937 S * 8/2017 Buck D12/209
D805,988 S * 12/2017 Buck D12/209
D808,323 S * 1/2018 Buck D12/209
D822,572 S * 7/2018 Smith D12/209
D829,631 S * 10/2018 Gallert D12/209
D840,320 S * 2/2019 Smith D12/209
D857,591 S * 8/2019 Brundle D12/209

* cited by examiner

Primary Examiner — Stacia A Cadmus

(74) *Attorney, Agent, or Firm* — Wood Herron & Evans
LLP

(57) **CLAIM**

The ornamental design for a wheel, as shown and described.

DESCRIPTION

FIG. 1 is a front left perspective view of a wheel for a vehicle according to the present invention.

FIG. 2 is a front view thereof; and,

FIG. 3 is a left side view, the right side, top, and bottom views being identical thereof.

In the drawings, the broken lines are included for the purpose of illustrating environment and form no part of the claimed design.

1 Claim, 3 Drawing Sheets

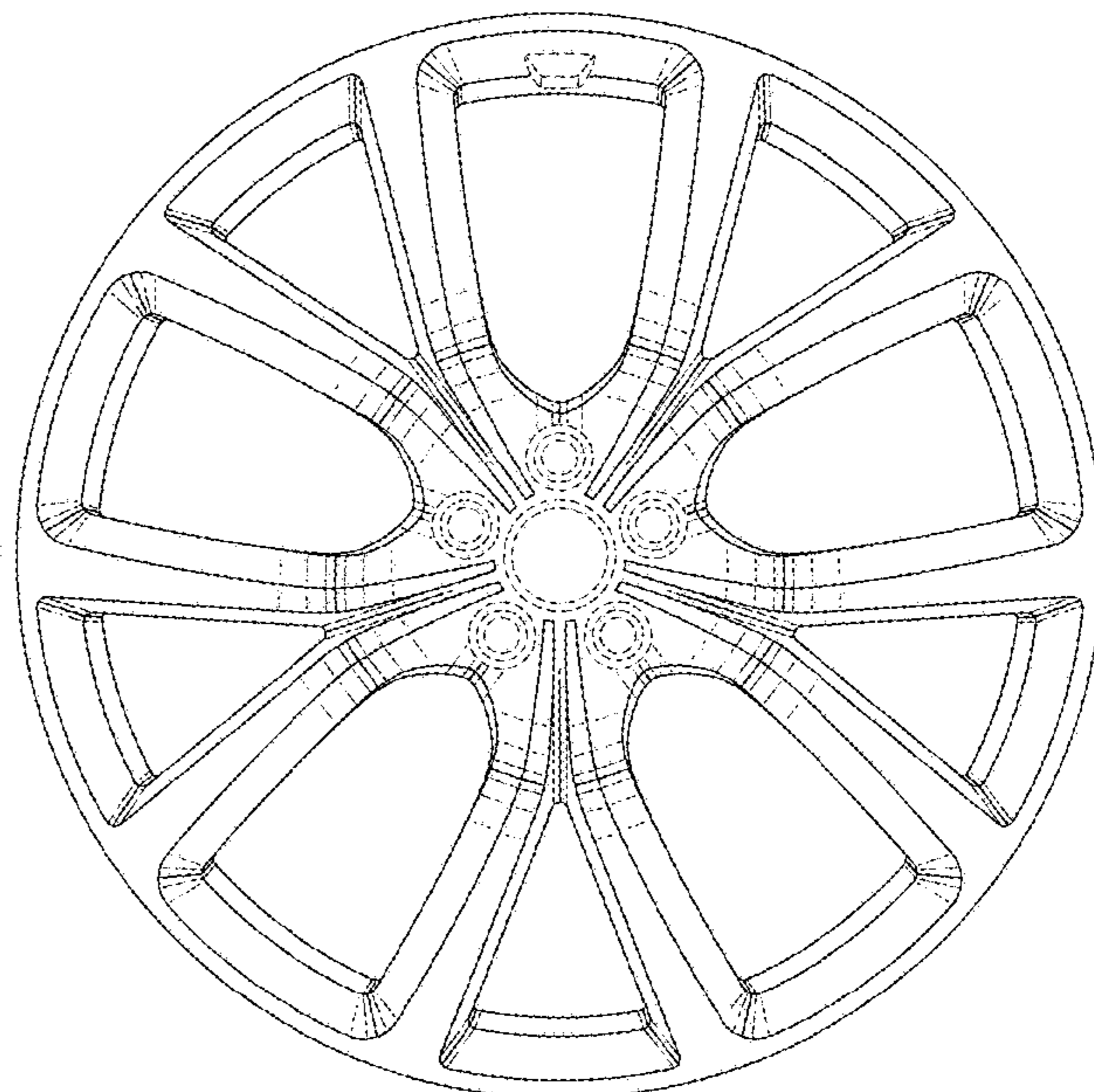
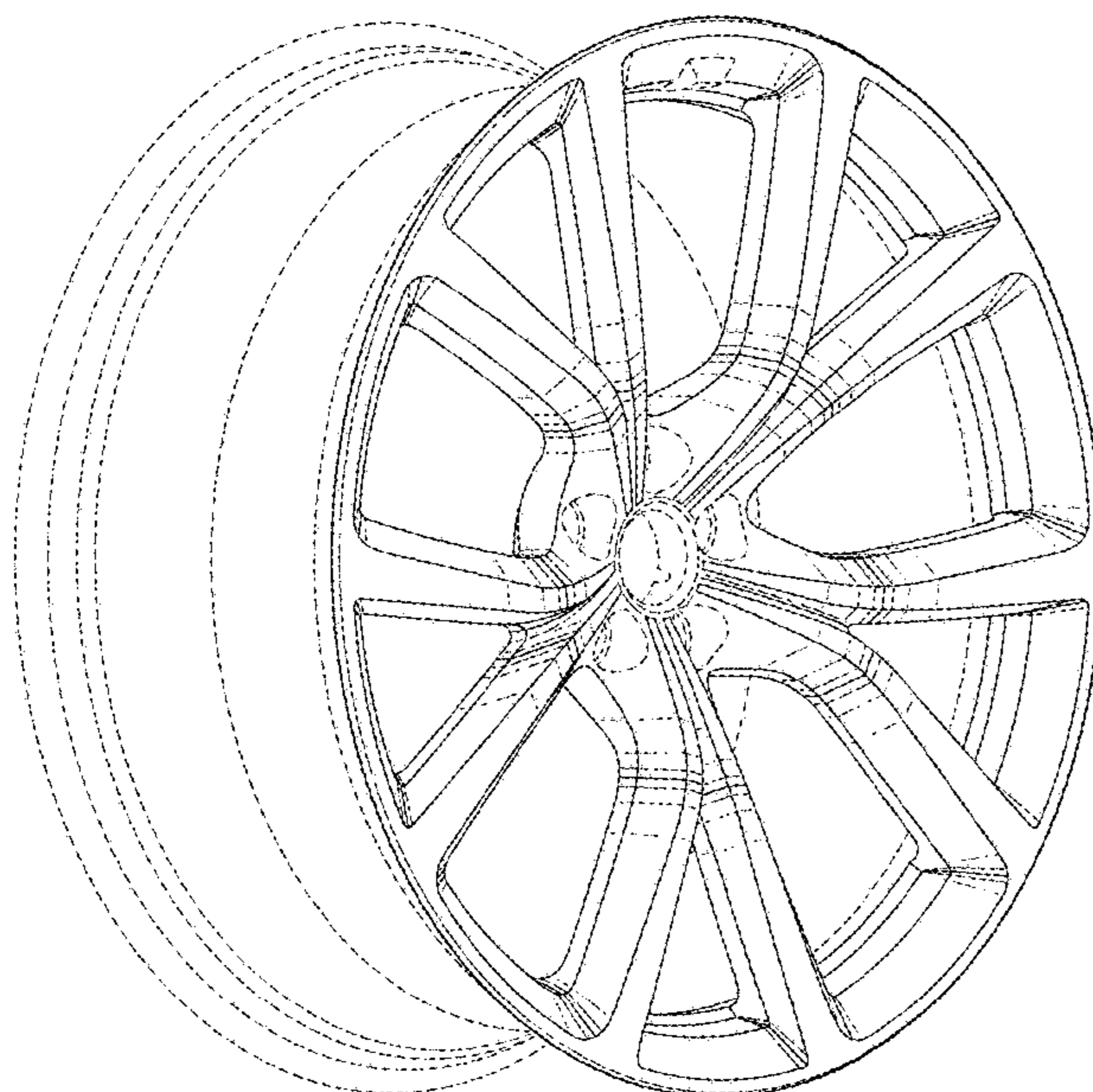

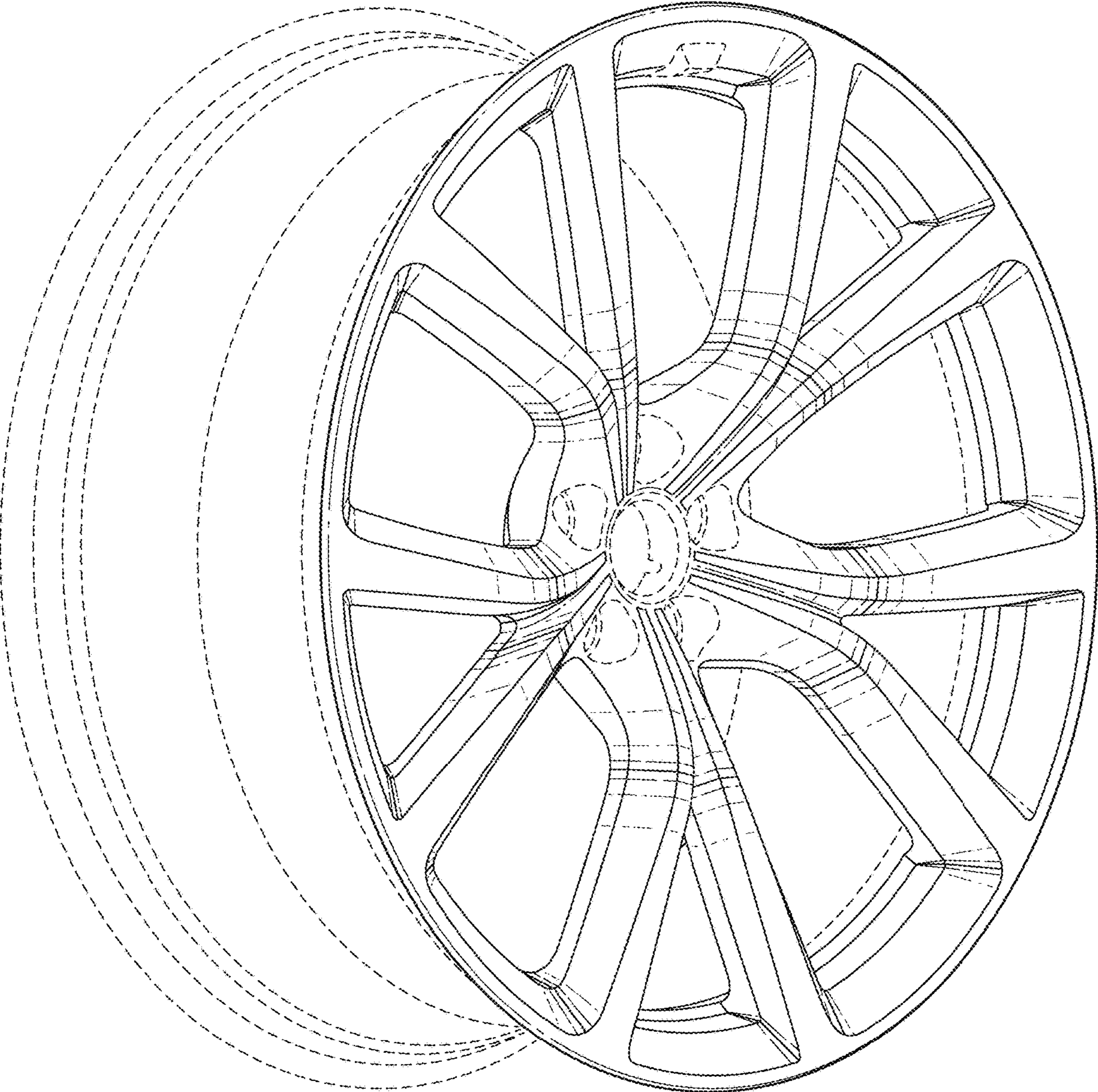

FIG. 1

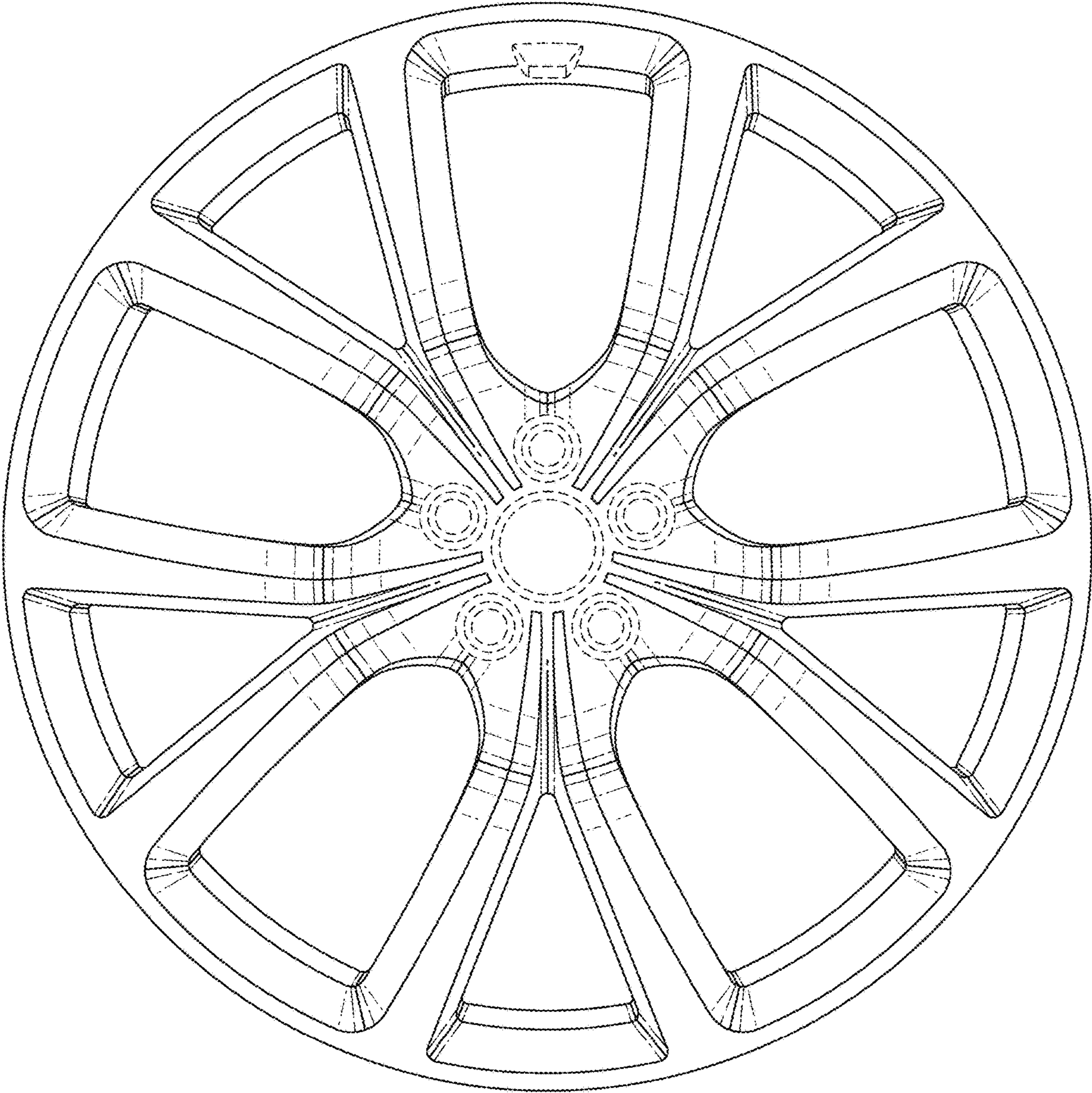

FIG. 2

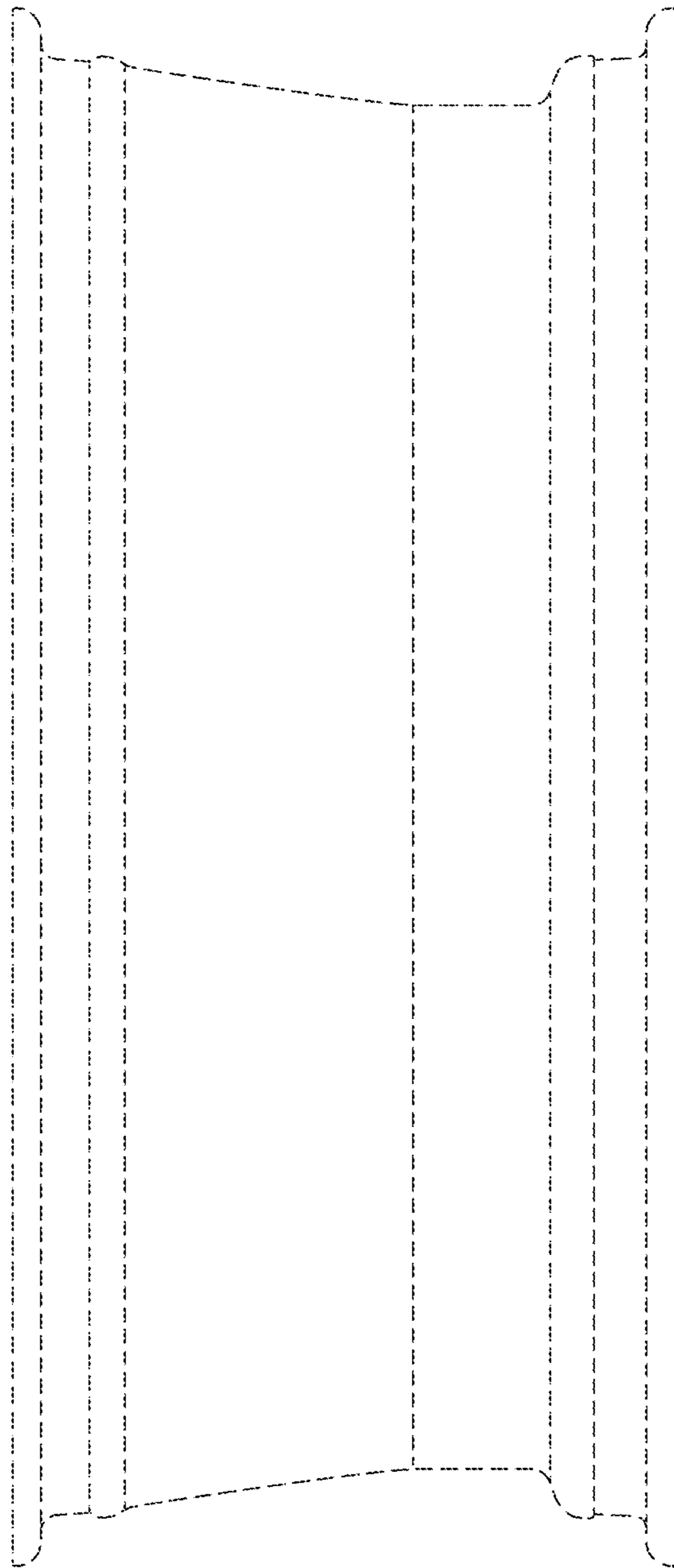

FIG. 3