



US00D889123S

(12) **United States Design Patent** (10) **Patent No.:** **US D889,123 S**
McCoy et al. (45) **Date of Patent:** **** Jul. 7, 2020**

(54) **FISHING ROD AND REEL BOX FOR VEHICLE ROOF**

Primary Examiner — W. A. Teddy Falloway
(74) *Attorney, Agent, or Firm* — Roger A. Jackson

(71) Applicants: **Earl McCoy**, Colorado Springs, CO (US); **Graham McCoy**, Colorado Springs, CO (US)

(57) **CLAIM**

The ornamental design for a fishing rod and reel box for vehicle roof, as substantially shown and described.

(72) Inventors: **Earl McCoy**, Colorado Springs, CO (US); **Graham McCoy**, Colorado Springs, CO (US)

DESCRIPTION

(**) Term: **15 Years**

(21) Appl. No.: **29/602,542**

(22) Filed: **May 1, 2017**

(51) **LOC (12) Cl.** **03-01**

(52) **U.S. Cl.**
USPC **D3/260**

(58) **Field of Classification Search**
USPC D3/260, 261, 262, 315, 254, 269;
D12/412, 413, 406; D6/552; D22/147;
224/328, 557, 569, 922, 400, 488, 42.08,
224/42.03, 320–323; 206/315.1, 315.11;
211/70.8, 60.1; 43/26; 248/514, 534,
248/538; 280/292, 769, 814
CPC A01K 97/08; B60R 9/08; B60R 9/055;
B60R 9/12; A63C 11/023; A63C 11/027;
A63C 11/028; A45C 11/00; Y10S
224/917; A45F 2003/142; A45F 3/14
See application file for complete search history.

FIG. 1 is a top perspective view of the fishing rod and reel box for vehicle roof of the present invention with the rear access panel in the partially open position;
FIG. 2 is a bottom perspective view of the fishing rod and reel box for vehicle roof of the present invention with the rear access panel in the closed position;
FIG. 3 is a top view of the fishing rod and reel box for vehicle roof of the present invention;
FIG. 4 is a bottom view of the fishing rod and reel box for vehicle roof of the present invention;
FIG. 5 is a front view of the fishing rod and reel box for vehicle roof of the present invention;
FIG. 6 is a rear view of the fishing rod and reel box for vehicle roof of the present invention, with the rear access panel in the closed position;
FIG. 7 is a rear view of the fishing rod and reel box for vehicle roof of the present invention, with the rear access panel in the open position;
FIG. 8 is a right side view of the fishing rod and reel box for vehicle roof of the present invention, with the rear access panel in the partially open position;
FIG. 9 is a right side view of the fishing rod and reel box for vehicle roof of the present invention, with the rear access panel in the closed position, the left side being a mirror image thereof; and,
FIG. 10 is a left side view of the fishing rod and reel box for vehicle roof of the present invention secured to the top of a vehicle.

The broken lines in FIG. 10 showing a vehicle illustrate environmental structure and form no part of the claimed design.

(56) **References Cited**

U.S. PATENT DOCUMENTS

2,640,622	A *	6/1953	Sabatino	A01K 97/08 220/521
2,650,449	A *	9/1953	Suring	A01K 97/08 43/26
2,902,790	A *	9/1959	Harvey	A01K 97/08 43/26

(Continued)

1 Claim, 8 Drawing Sheets

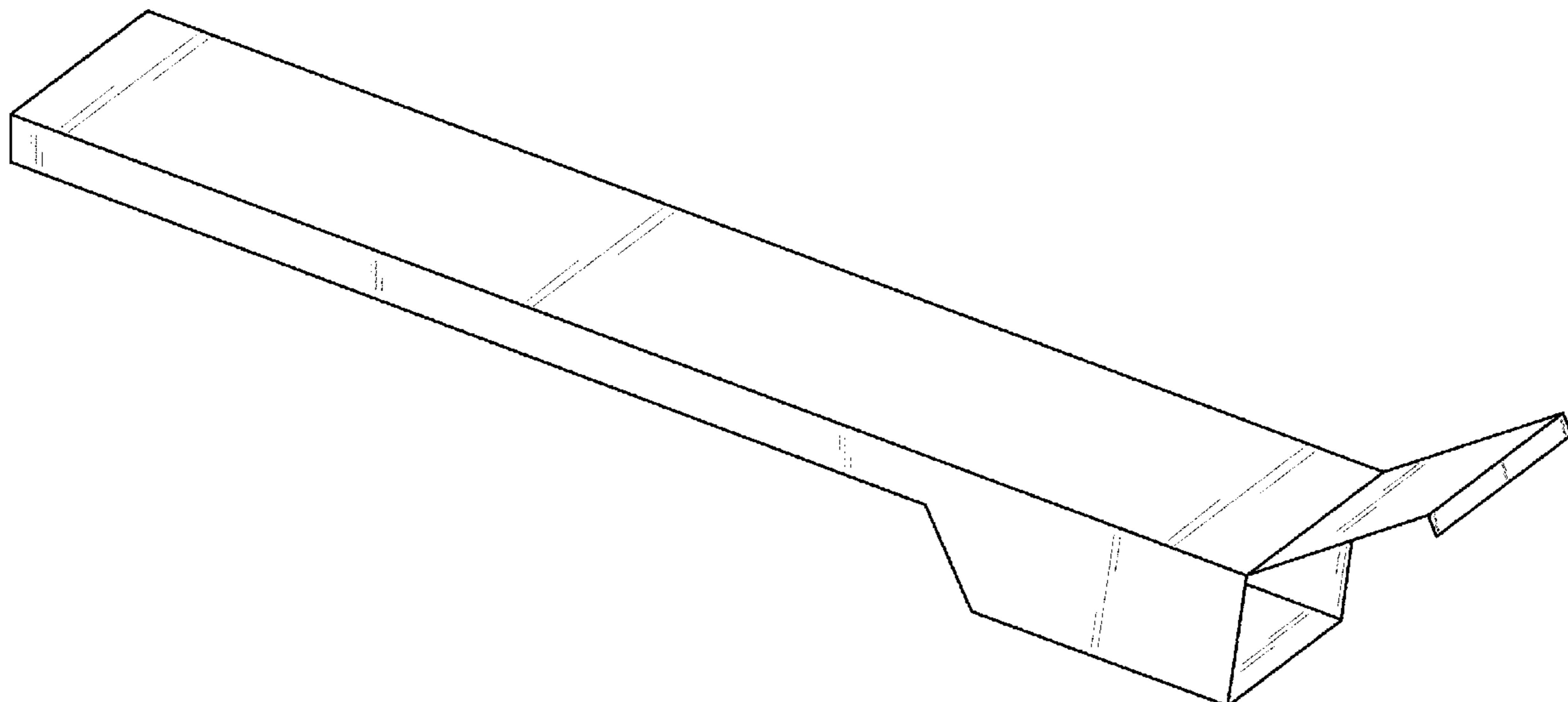

(56)

References Cited

U.S. PATENT DOCUMENTS

3,033,259 A * 5/1962 Landis, Sr. A01K 97/08
206/315.11
3,207,296 A * 9/1965 Goodall A45D 44/18
206/209.1
3,662,933 A 5/1972 Michal
3,772,819 A * 11/1973 Ratzlaff A01K 97/08
43/26
D238,824 S * 2/1976 Michal D3/260
D238,825 S * 2/1976 Michal D3/260
4,126,254 A * 11/1978 Sahakian A45C 11/00
206/315.1
4,162,004 A * 7/1979 Thomas B25H 3/006
206/317
4,184,223 A * 1/1980 Price A46D 1/00
15/179
D267,443 S * 1/1983 Salas D3/261
4,484,373 A * 11/1984 Price A46D 1/00
15/179
4,523,704 A 6/1985 Washington
D284,423 S * 7/1986 McCallum D3/260
D296,387 S * 6/1988 Anderson D3/261
4,967,504 A * 11/1990 Craft A01K 97/08
43/26

D316,327 S * 4/1991 Craft D3/260
D321,430 S * 11/1991 Wirth D3/261
D337,086 S * 7/1993 Theodorsen D12/404
5,285,942 A * 2/1994 Wills A63C 11/026
220/4.22
D368,369 S * 4/1996 Pease D3/269
D458,747 S * 6/2002 Hields D3/260
D473,181 S * 4/2003 Schappach D12/413
D487,720 S * 3/2004 Thomas D12/414
8,746,469 B1 6/2014 De LaTorre
D714,547 S * 10/2014 Enes D3/261
D718,527 S * 12/2014 Enes D3/261
D805,148 S * 12/2017 Ford D21/754
10,118,083 B2 * 11/2018 Ford A63C 11/023
D846,058 S * 4/2019 Dennett D22/108
10,375,944 B2 * 8/2019 Smigaj B60R 9/08
10,486,612 B2 * 11/2019 McCoy B60R 9/055
2004/0045212 A1 * 3/2004 Henault A01K 97/08
43/26
2005/0279663 A1 * 12/2005 Citrigno A47K 1/09
206/362.1
2019/0054862 A1 * 2/2019 McCoy B60R 9/08
2019/0110456 A1 * 4/2019 Smigaj A01K 97/08
2019/0230911 A1 * 8/2019 Smigaj A01K 97/08

* cited by examiner

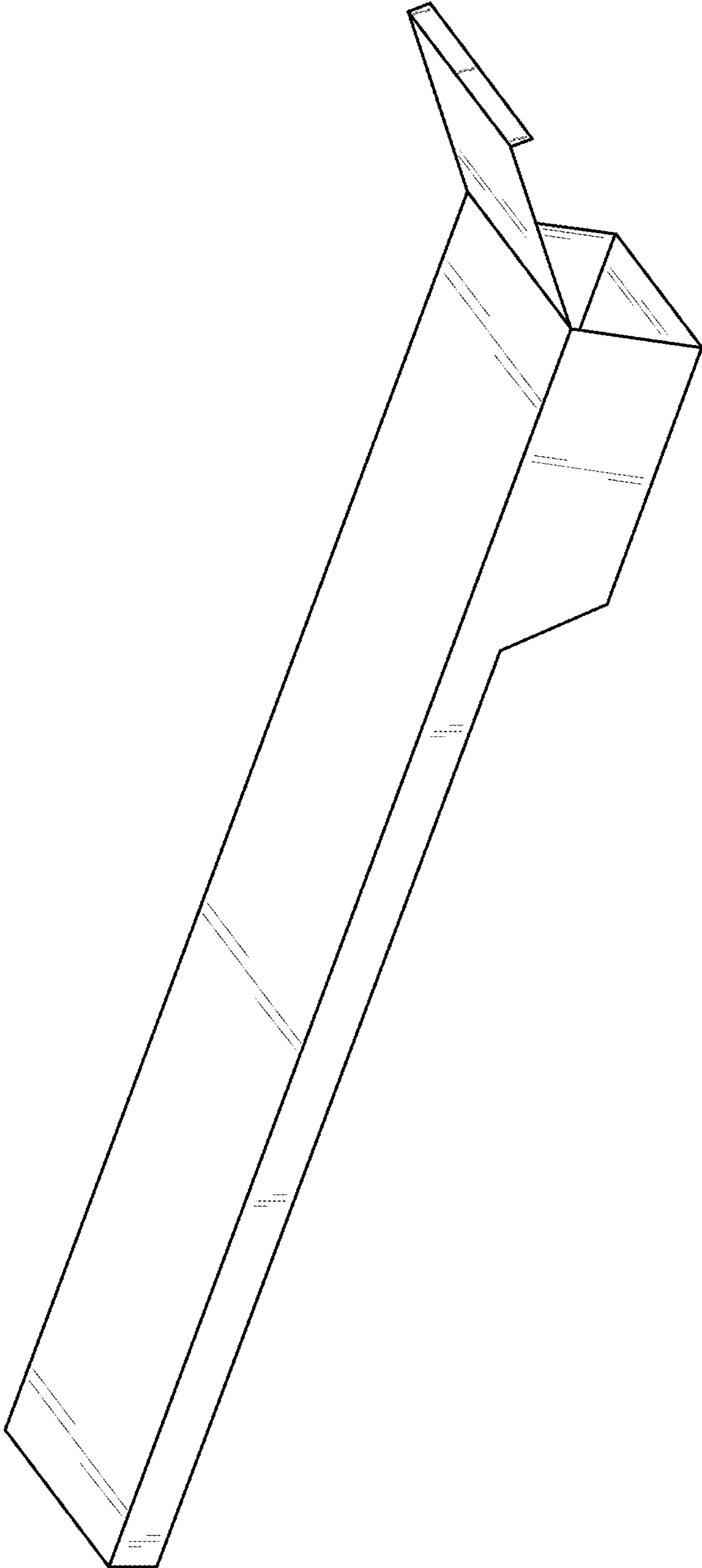

FIG. 1

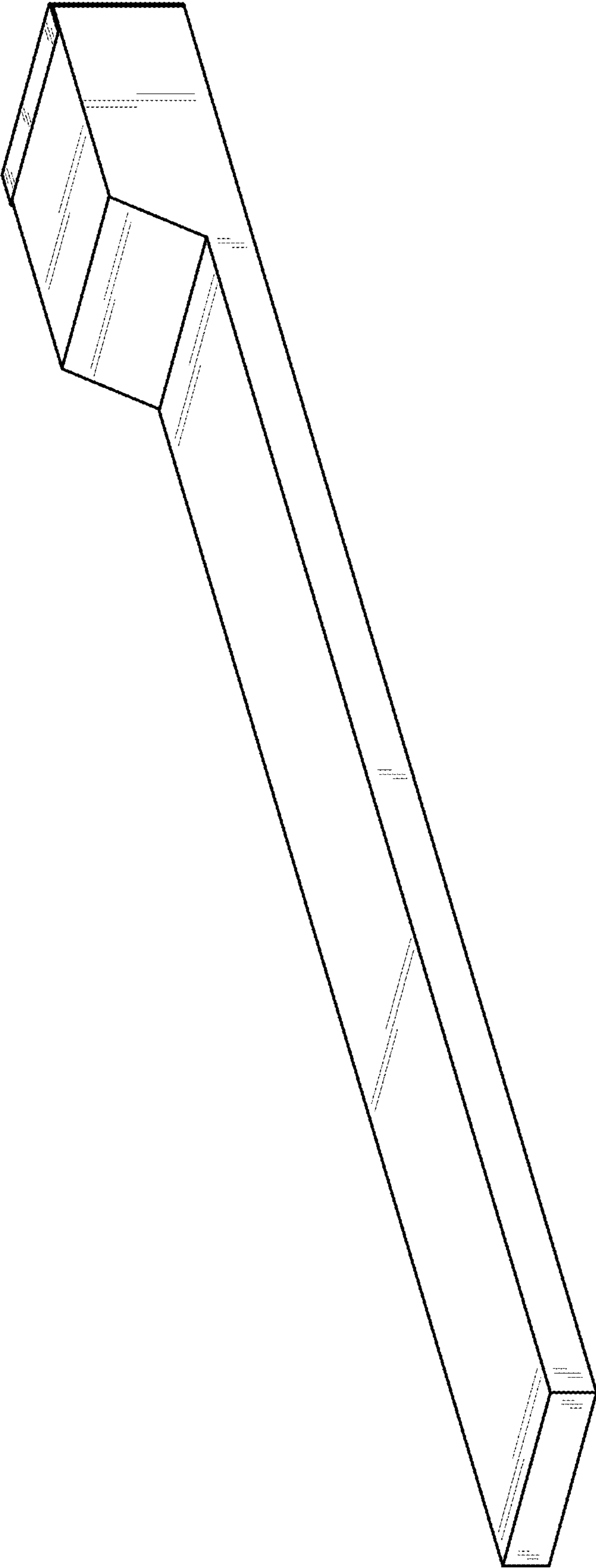

FIG. 2

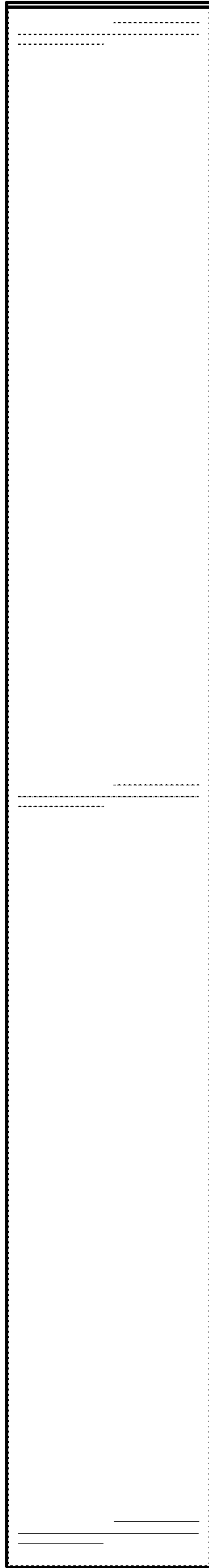

FIG. 3

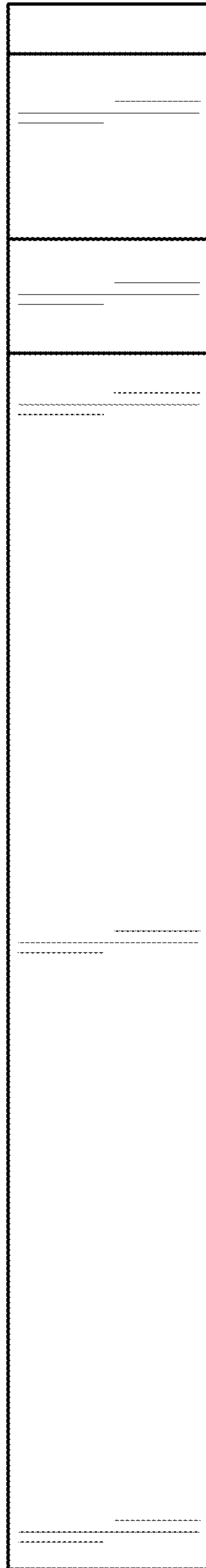

FIG. 4

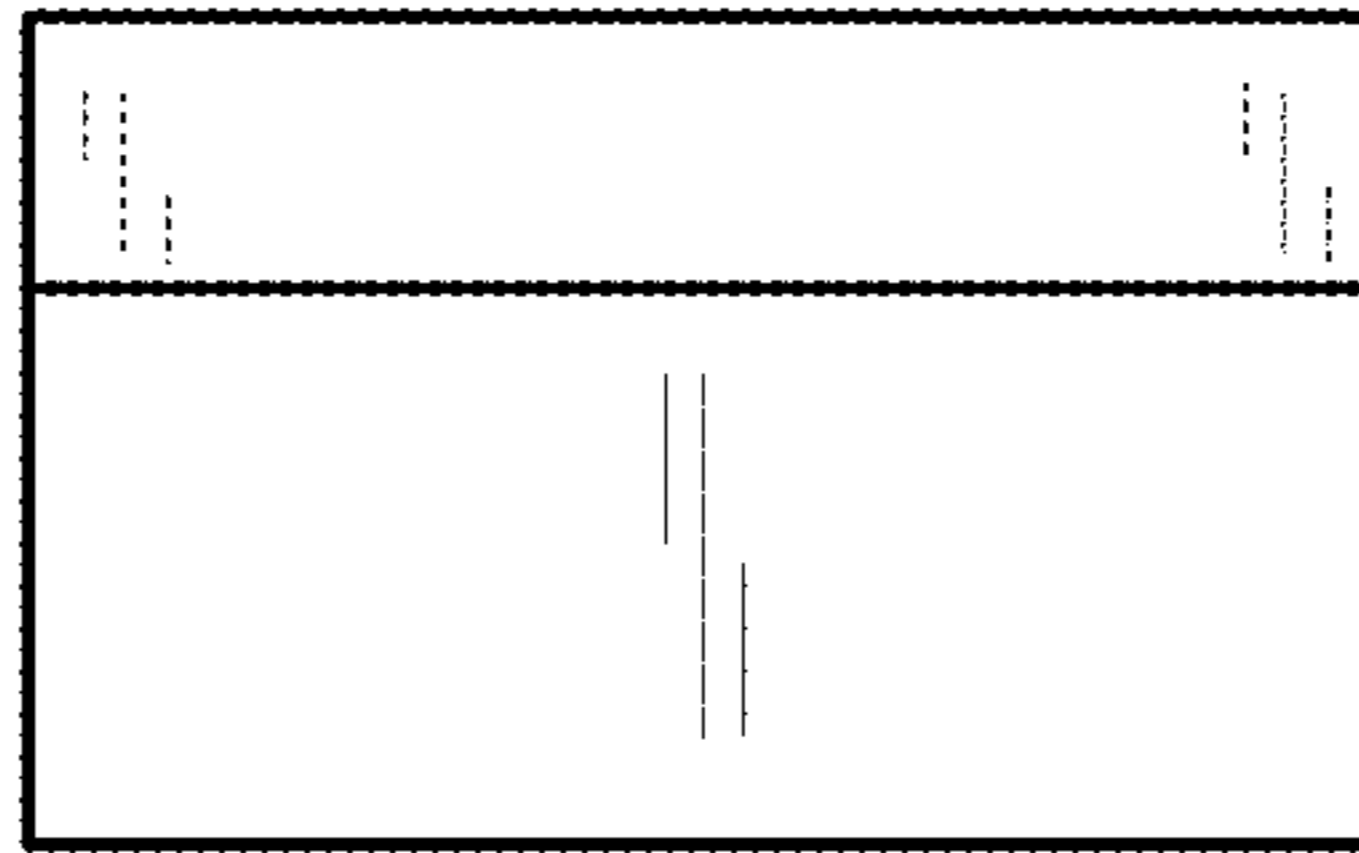

FIG. 5

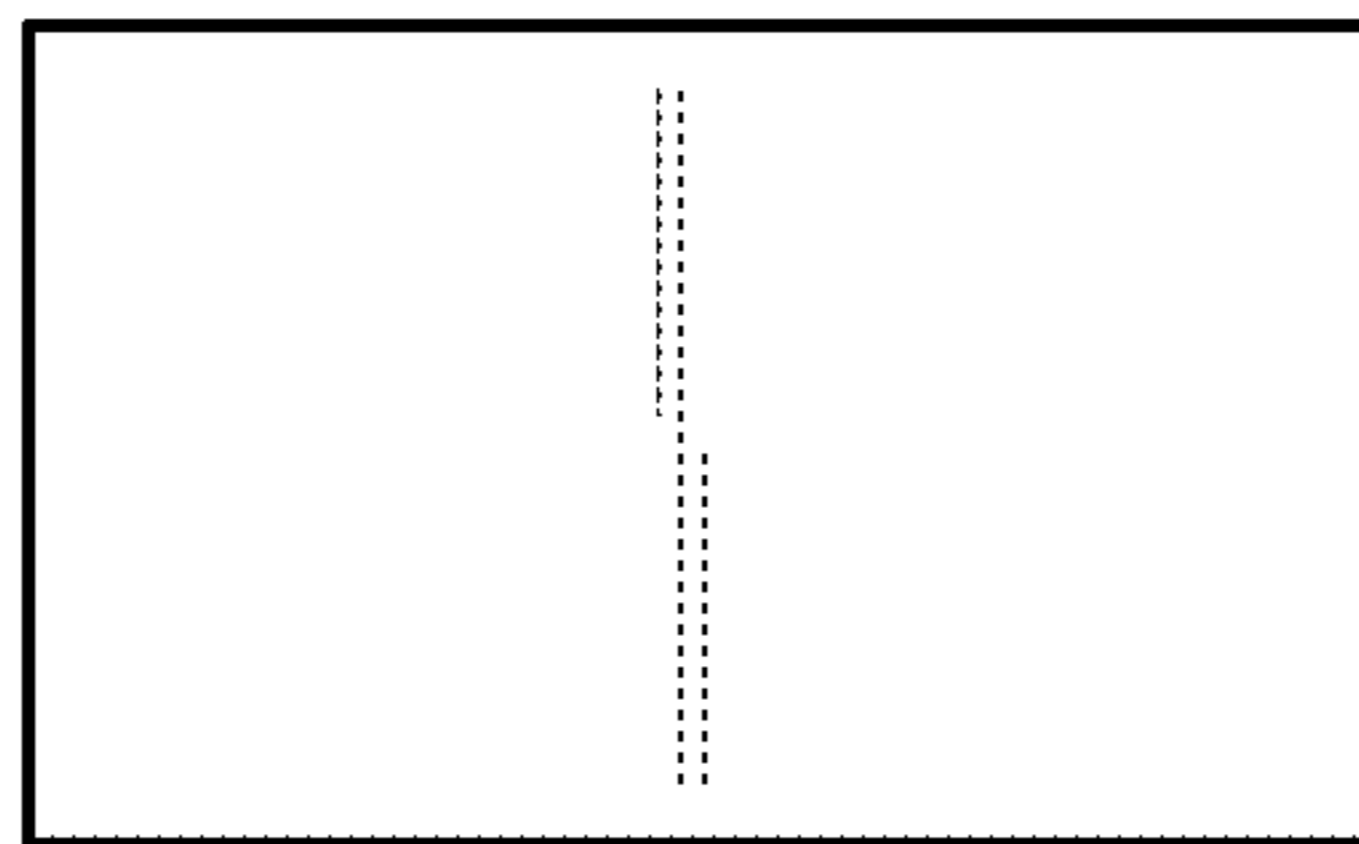

FIG. 6

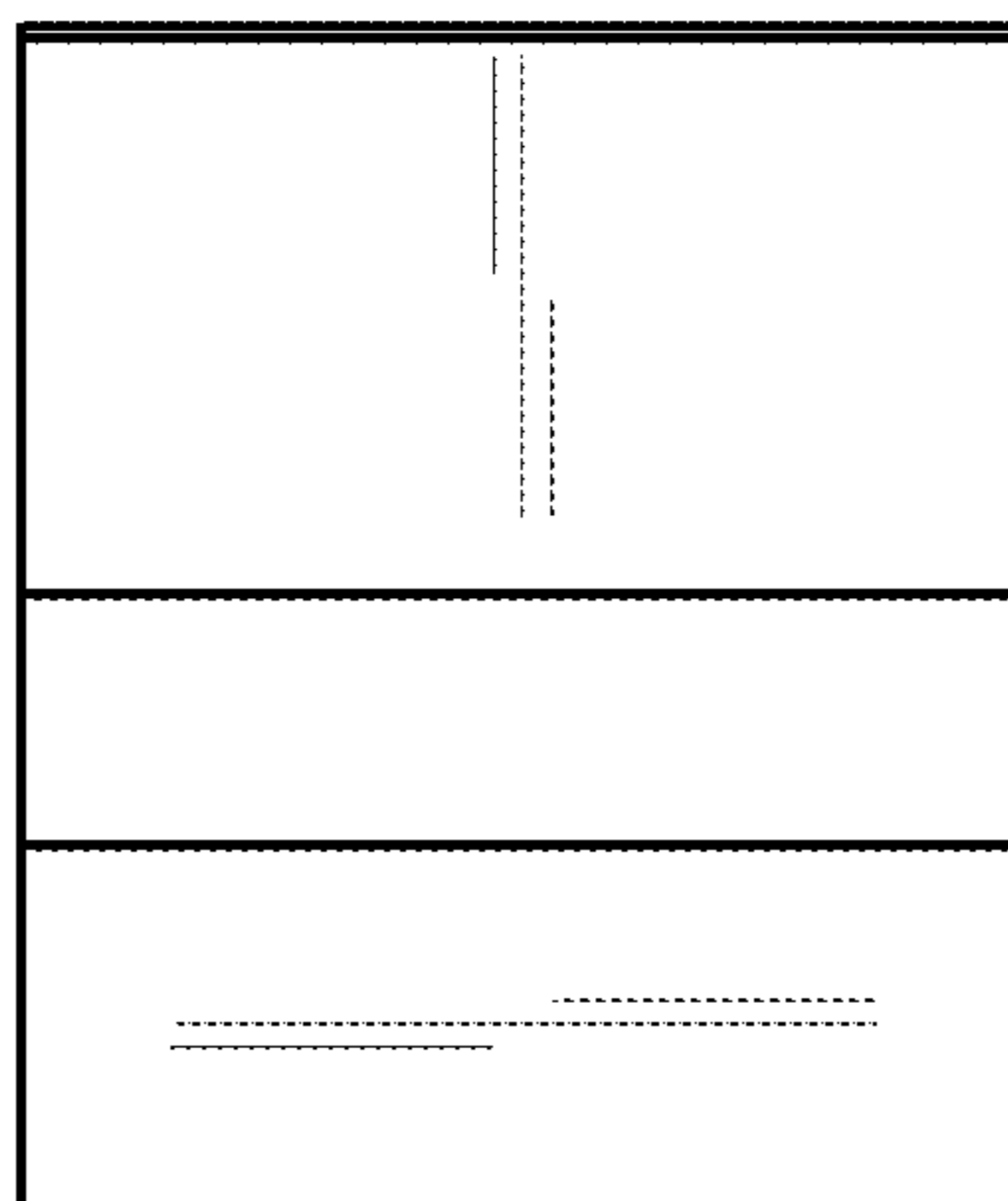

FIG. 7

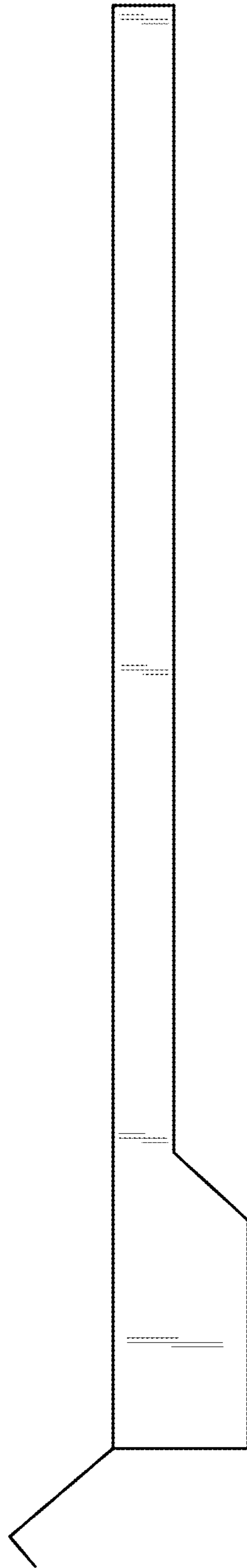

FIG. 8

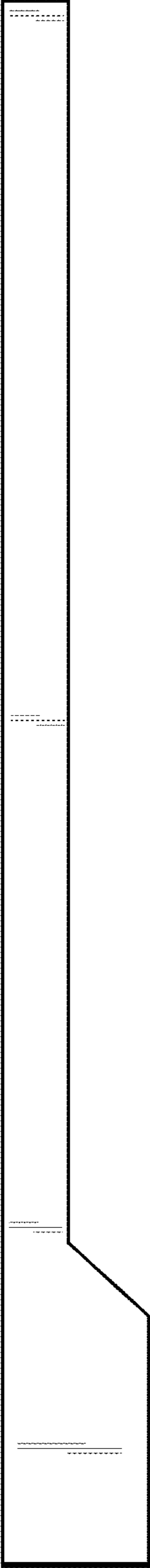

FIG. 9

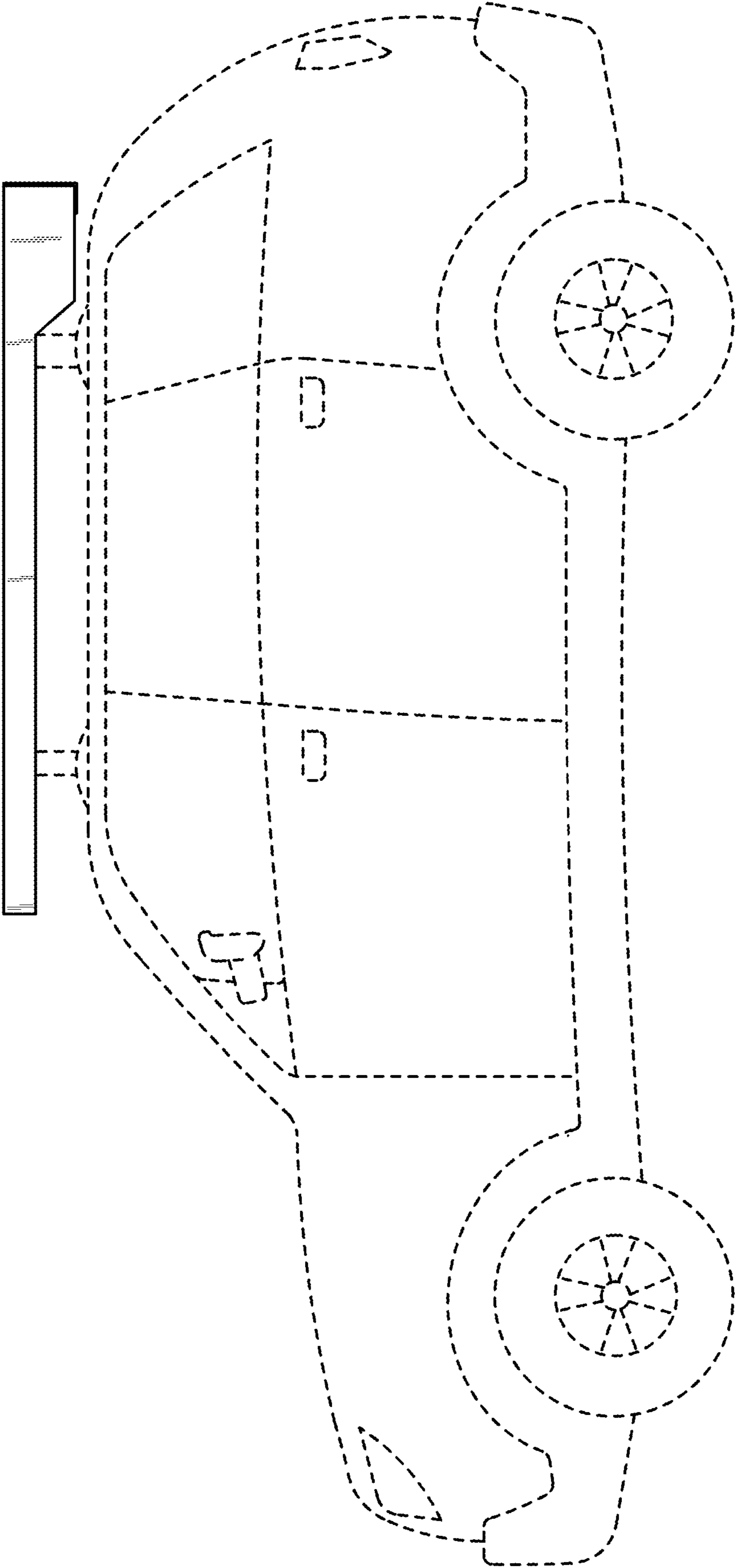

FIG. 10