



US00D888999S

(12) **United States Design Patent**
Zhang et al.

(10) **Patent No.:** **US D888,999 S**
(45) **Date of Patent:** **** Jun. 30, 2020**

(54) **AUTOMOBILE HEADLAMP**
(71) Applicant: **Chongqing Jinkang New Energy Automobile Co., Ltd.**, Chongqing (CN)
(72) Inventors: **Mengping Zhang**, Chongqing (CN); **Jianghua Ren**, Chongqing (CN); **Jinlin Xue**, Chongqing (CN)

D569,015 S * 5/2008 Tsukui D26/28
D573,734 S * 7/2008 Watanabe D26/28
D603,076 S * 10/2009 Hung D26/28

* cited by examiner

(**) Term: **15 Years**

Primary Examiner — Marcus A Jackson
(74) *Attorney, Agent, or Firm* — Kilpatrick Townsend & Stockton, LLP

(21) Appl. No.: **29/678,072**

(22) Filed: **Jan. 25, 2019**

(57) **CLAIM**

The ornamental design of an automobile headlamp, as shown and described.

(30) **Foreign Application Priority Data**

Jul. 25, 2018 (CN) 2018 3 0404123

(51) **LOC (12) Cl.** **26-06**

(52) **U.S. Cl.**
USPC **D26/28**

DESCRIPTION

(58) **Field of Classification Search**
USPC D26/28-36, 139
CPC F21S 48/00; F21S 48/10; F21S 48/115;
F21S 48/225; F21S 48/1233; F21S
48/1266; F21S 48/1388; F21S 48/2268;
F21V 21/04; F21V 29/004; B60Q 9/13;
B60Q 9/135; B60Q 9/1375

FIG. 1 is a top plan view of the automobile headlamp showing our new design;
FIG. 2 is a bottom plan view thereof;
FIG. 3 is a front elevation view thereof;
FIG. 4 is a rear elevation view thereof;
FIG. 5 is a left side elevation view thereof; and,
FIG. 6 is a right side elevation view thereof.

See application file for complete search history.

The broken lines immediately adjacent the shaded areas represent the bounds of the claimed design while other broken lines are directed to environment and/or are for illustrative purposes only. The broken lines form no part of the claimed design.

(56) **References Cited**

U.S. PATENT DOCUMENTS

D552,274 S * 10/2007 Tanaka D26/28
D568,501 S * 5/2008 Nakazawa D26/28

1 Claim, 6 Drawing Sheets

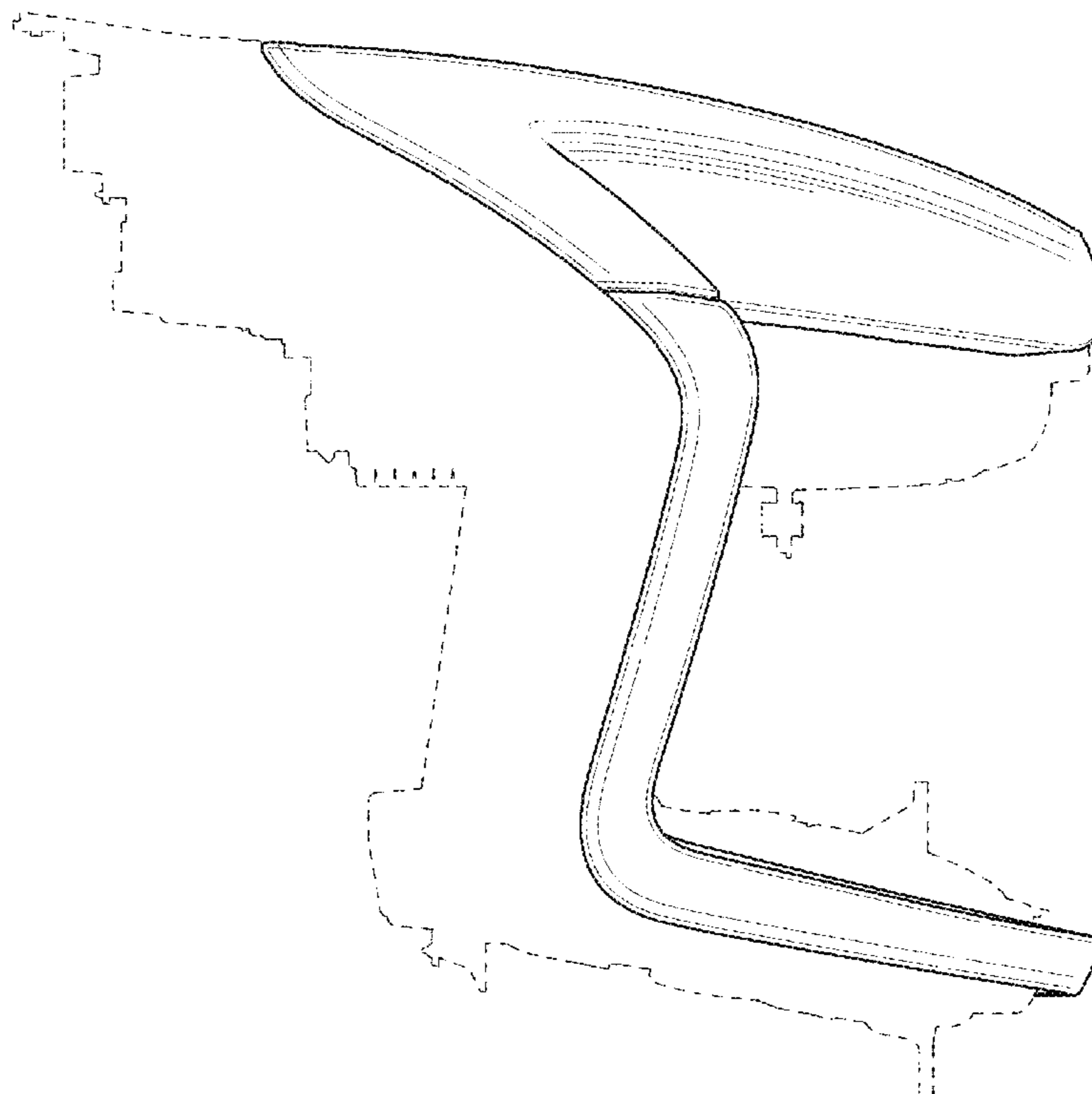



FIG. 1



FIG. 2

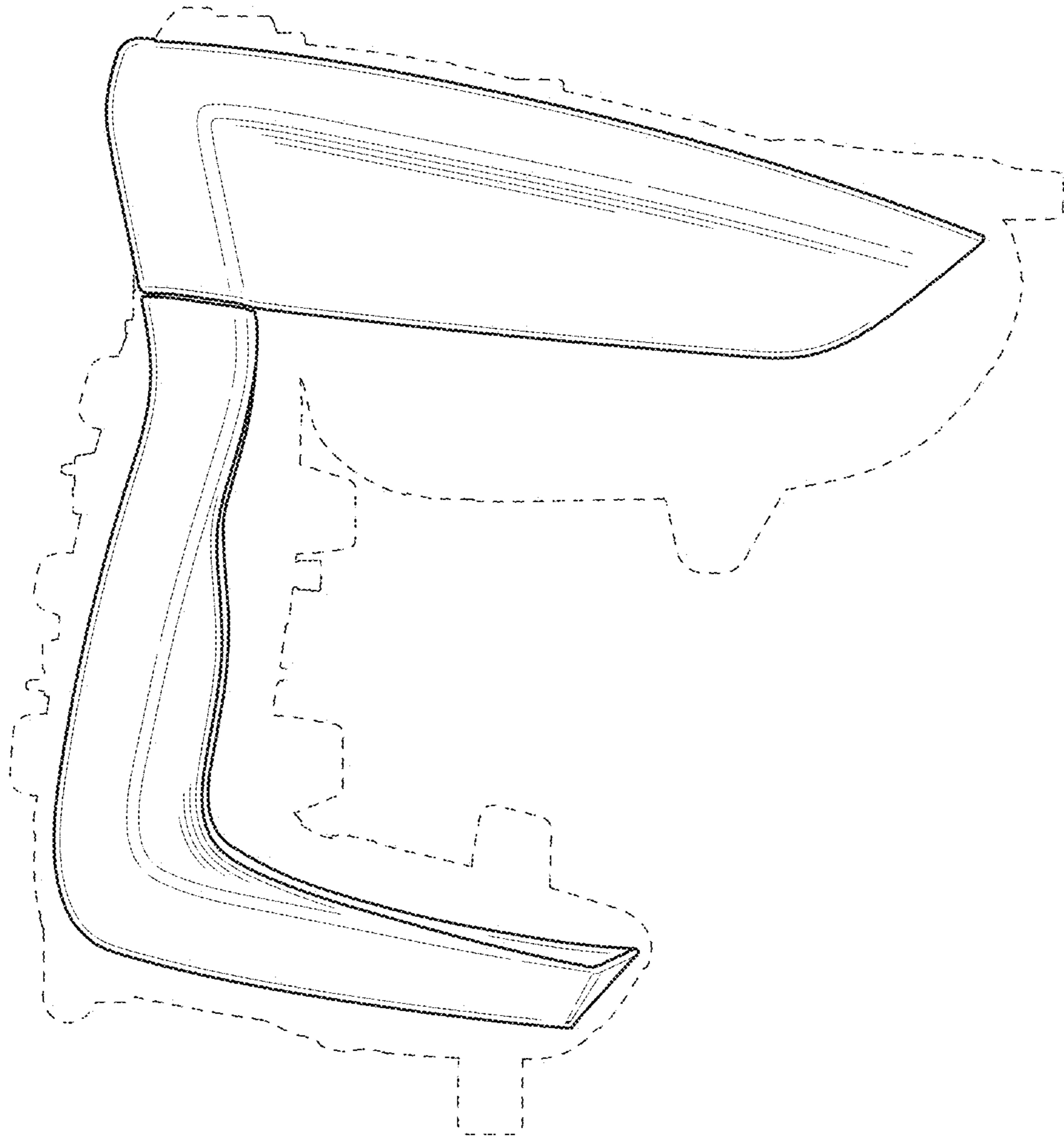

FIG. 3



FIG. 4

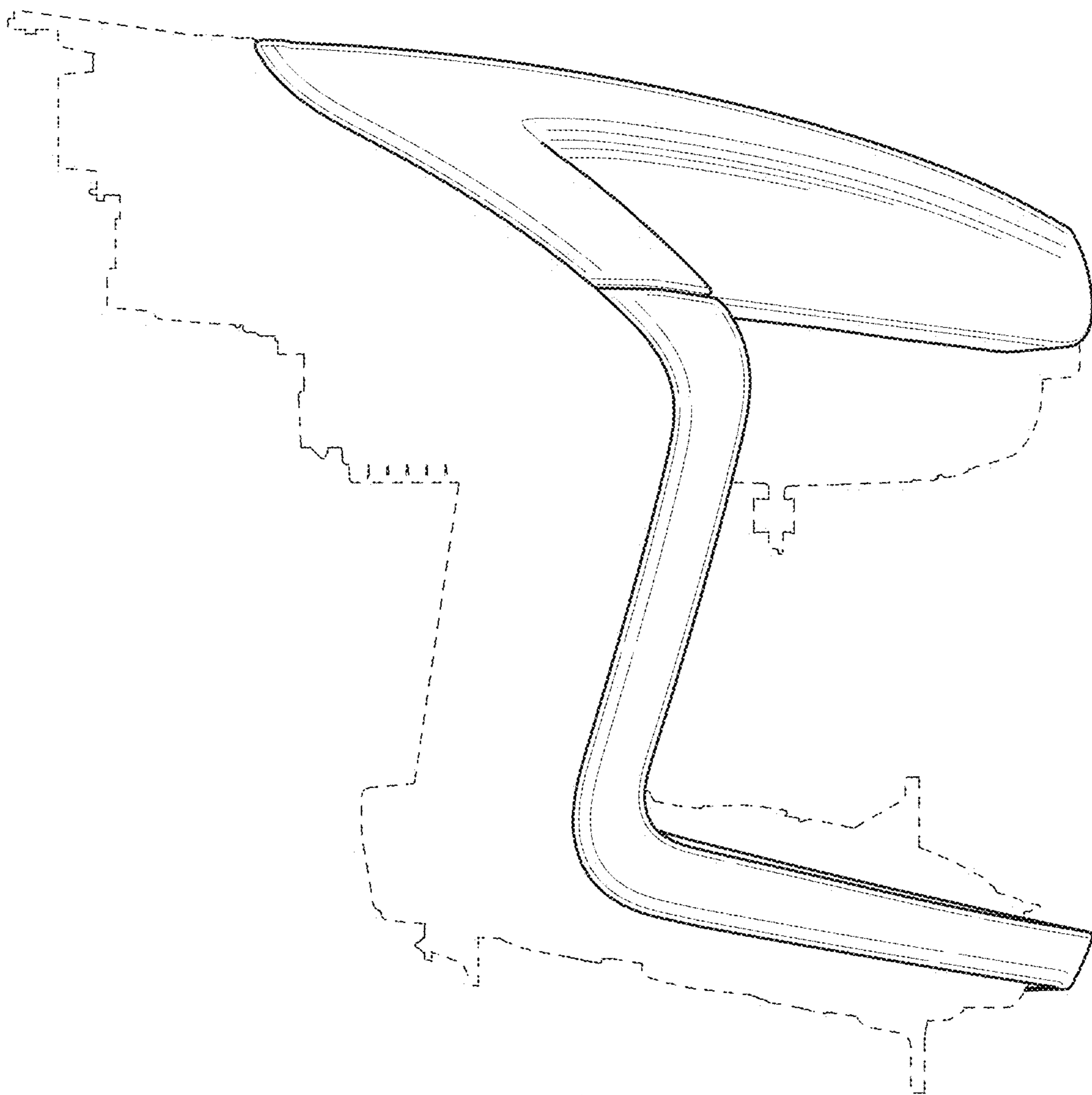

FIG. 5

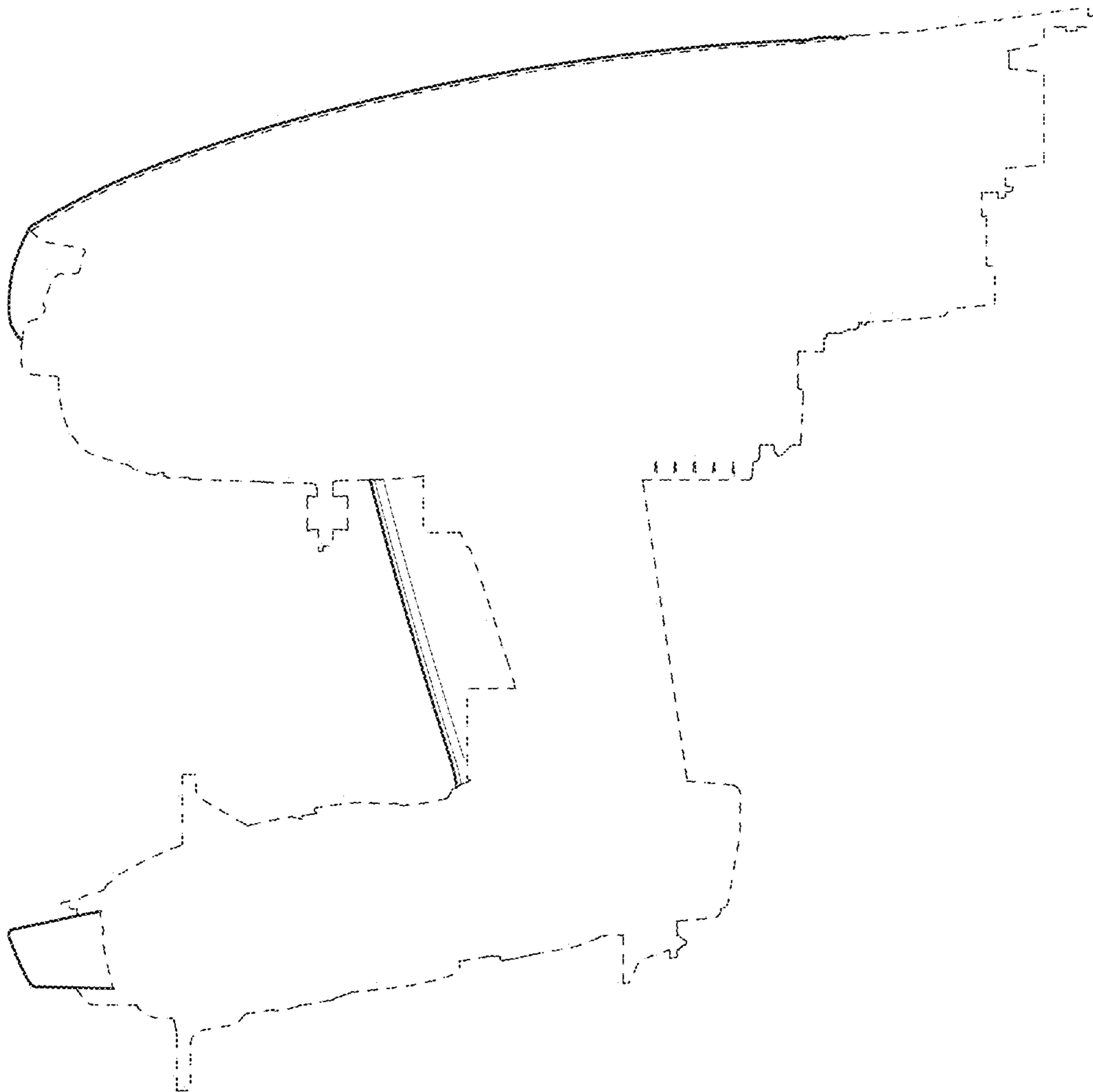

FIG. 6