



US00D888820S

(12) **United States Design Patent**
Kiesel

(10) **Patent No.:** **US D888,820 S**
(45) **Date of Patent:** **** Jun. 30, 2020**

(54) **GUITAR HEADSTOCK**

(71) Applicant: **Jeff Kiesel**, Escondido, CA (US)

(72) Inventor: **Jeff Kiesel**, Escondido, CA (US)

(**) Term: **15 Years**

(21) Appl. No.: **29/681,809**

(22) Filed: **Feb. 28, 2019**

(51) **LOC (12) Cl.** **17-03**

(52) **U.S. Cl.**
USPC **D17/20**

(58) **Field of Classification Search**
USPC D17/14, 18, 19, 20, 21, 99; D21/405
CPC .. G10D 1/08; G10D 1/10; G10D 3/00; G10D
3/04; G10D 3/06; G10D 3/16; G10D
3/173; G09B 15/001; G09B 15/02; G09B
15/008
See application file for complete search history.

(56) **References Cited**

U.S. PATENT DOCUMENTS

| | | | | |
|--------------|---------|-------------|-------|--------|
| D255,462 S * | 6/1980 | Todd, III | | D17/20 |
| D277,765 S * | 2/1985 | Sugai | | D17/20 |
| D313,609 S * | 1/1991 | Mulroy, Jr. | | D17/20 |
| D314,784 S * | 2/1991 | Powers | | D17/20 |
| D404,061 S * | 1/1999 | Roth | | D17/20 |
| D416,935 S * | 11/1999 | DeCola | | D17/20 |
| D555,191 S * | 11/2007 | Peavey | | D17/20 |
| D572,302 S * | 7/2008 | Peavey | | D17/20 |
| D643,460 S * | 8/2011 | Barkdull | | D17/20 |
| D677,713 S * | 3/2013 | Blanc | | D17/20 |
| D681,102 S * | 4/2013 | Yi | | D17/20 |
| D785,080 S * | 4/2017 | Kiesel | | D17/20 |

FOREIGN PATENT DOCUMENTS

WO WO-2018029686 A1 * 2/2018 G10G 7/02

OTHER PUBLICATIONS

Wikipedia. https://en.wikipedia.org/wiki/File:Stinger_guitar_headstock.jpg. "File:Stinger guitar headstock.jpg". May 21, 2016. (Year: 2016).*

* cited by examiner

Primary Examiner — R. Johnson

(74) *Attorney, Agent, or Firm* — Plager Schack LLP;
Mark H. Plager

(57) **CLAIM**

The ornamental design for a guitar headstock, as shown and described.

DESCRIPTION

FIG. 1 is a perspective view of the guitar headstock showing my new design;
FIG. 2 is a front view thereof;
FIG. 3 is a rear view thereof;
FIG. 4 is a left side view thereof;
FIG. 5 is a right side view thereof;
FIG. 6 is a top view thereof;
FIG. 7 is a bottom view thereof;
FIG. 8 is another perspective view thereof;
FIG. 9 is another front view thereof;
FIG. 10 is another rear view thereof;
FIG. 11 is another left side view thereof;
FIG. 12 is another right side view thereof;
FIG. 13 is another top view thereof; and,
FIG. 14 is another bottom view thereof.
The broken lines represent environmental structure and the portions of the guitar headstock that form no part of the claimed design.

1 Claim, 14 Drawing Sheets

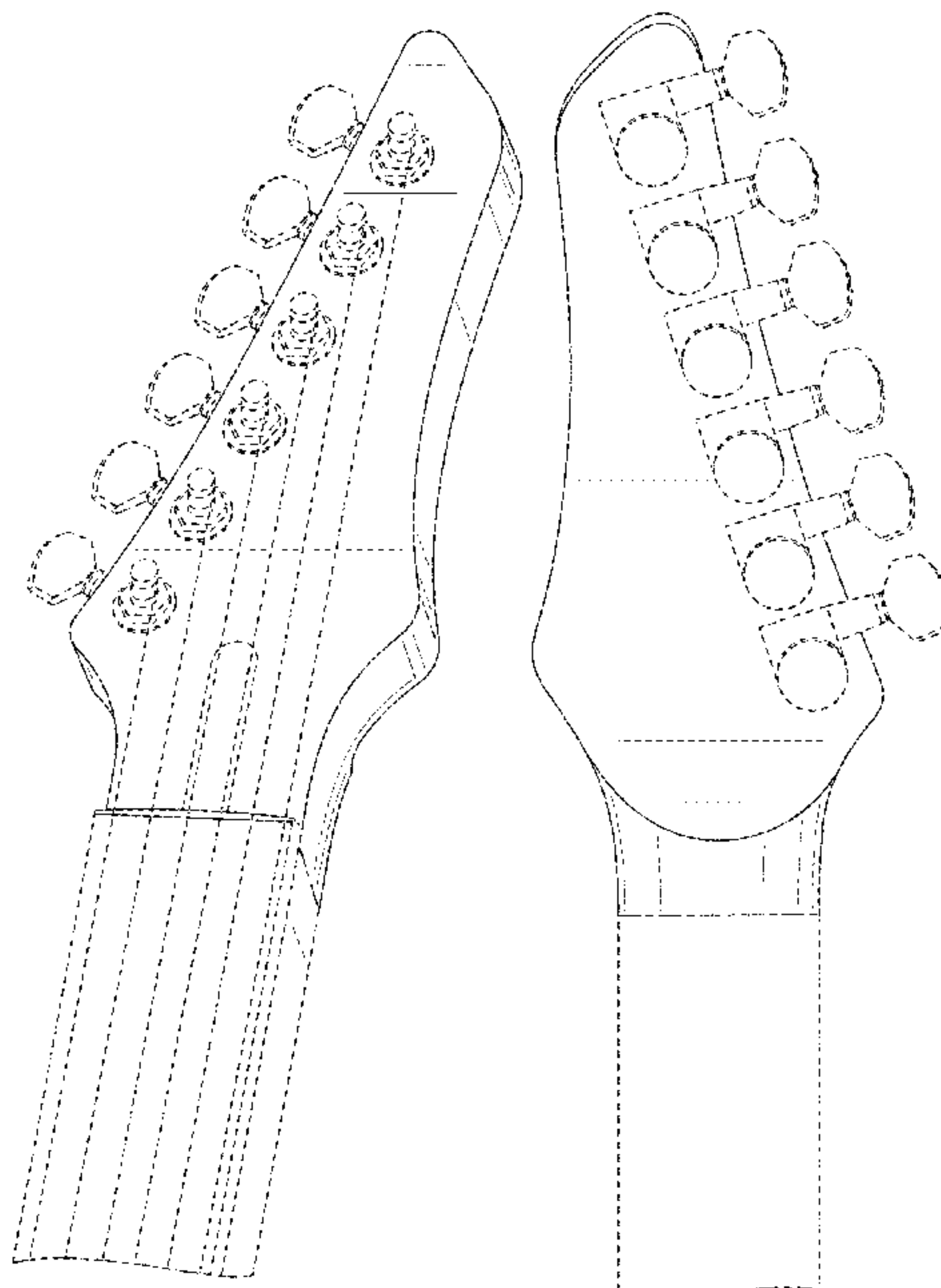

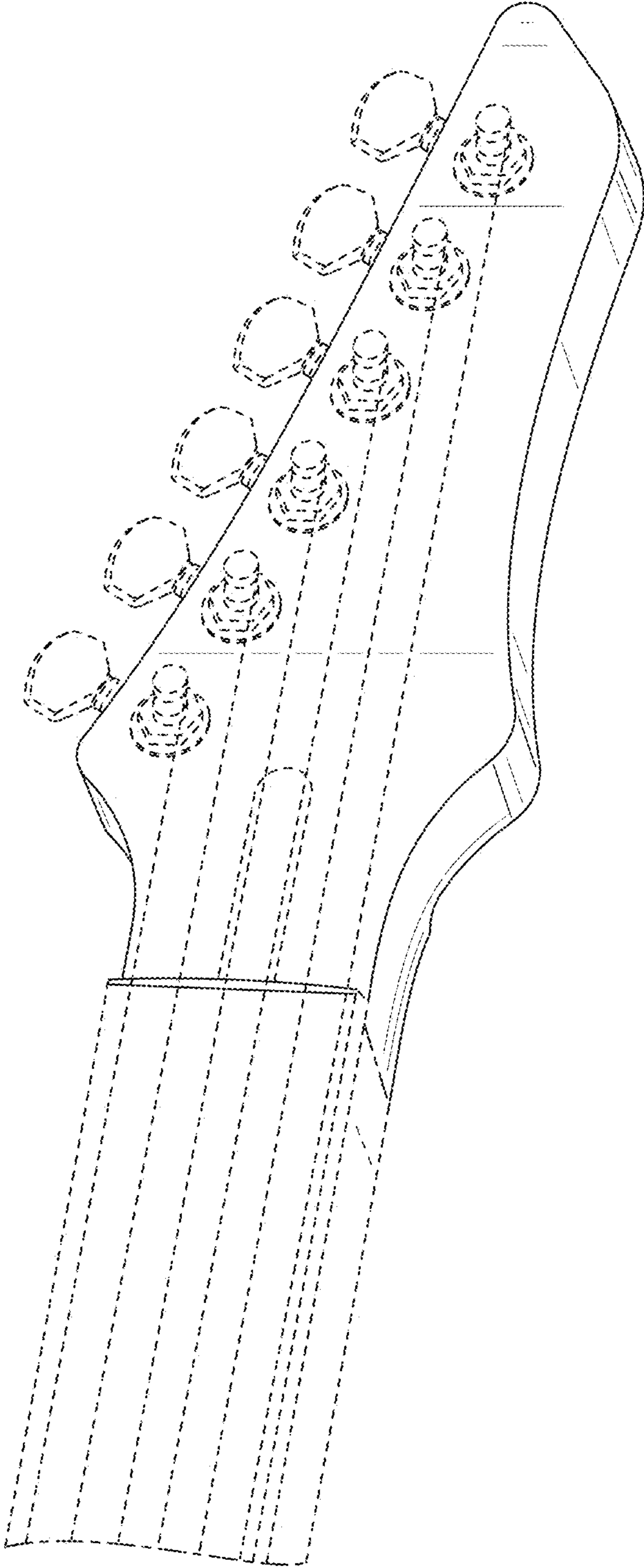

FIG. 1

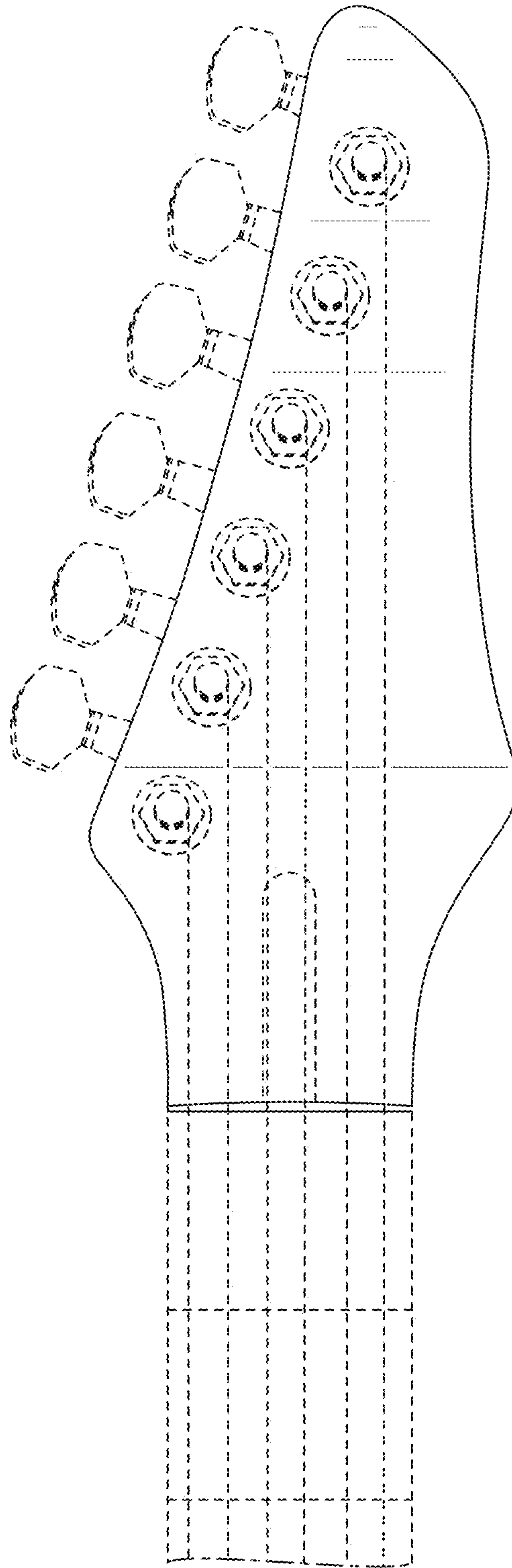

FIG. 2

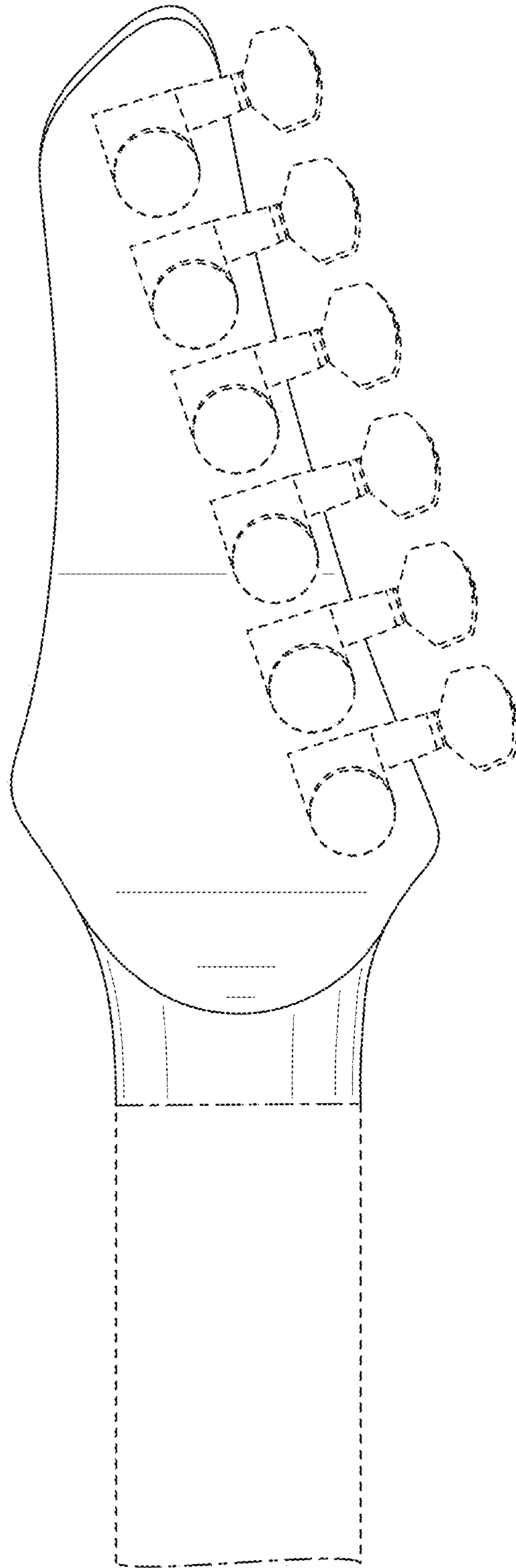

FIG. 3

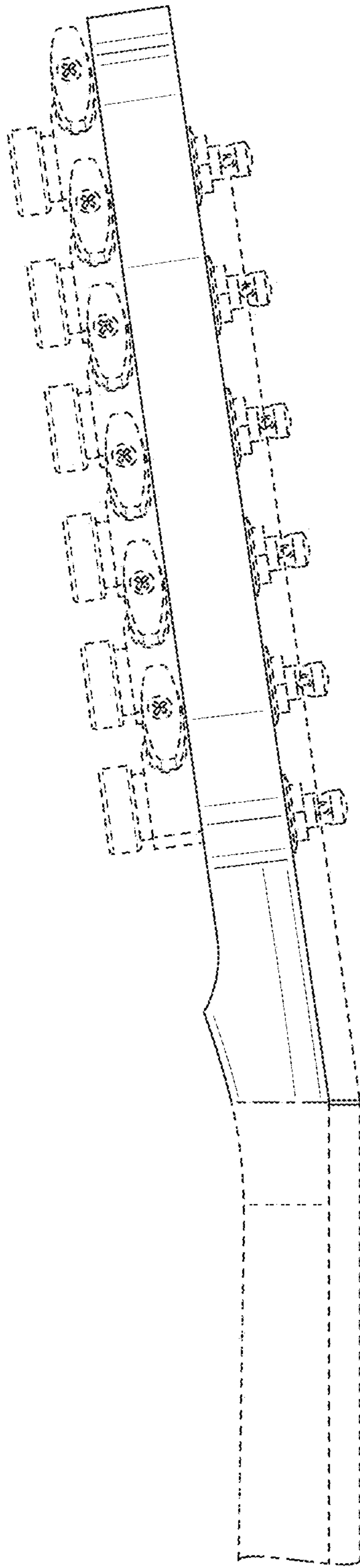

FIG. 4

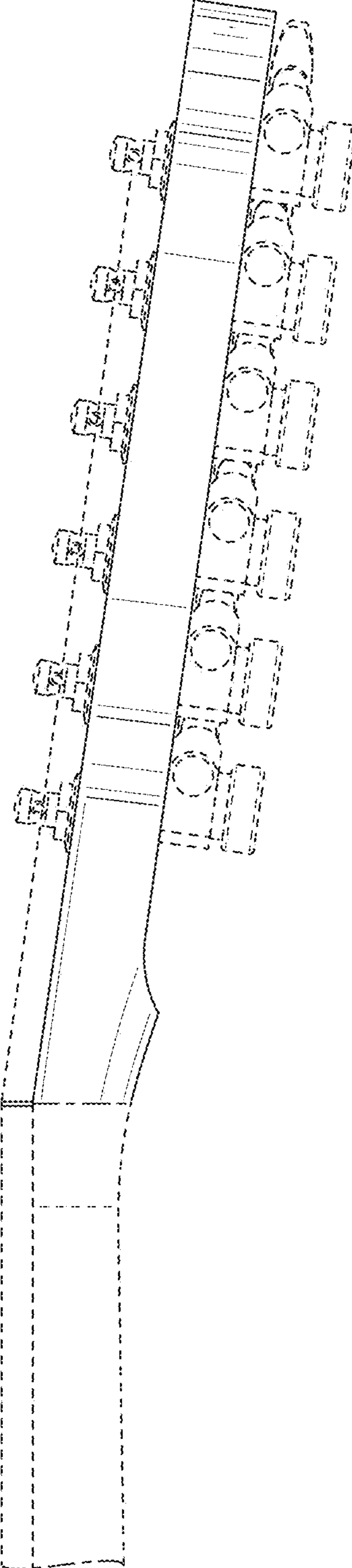

FIG. 5

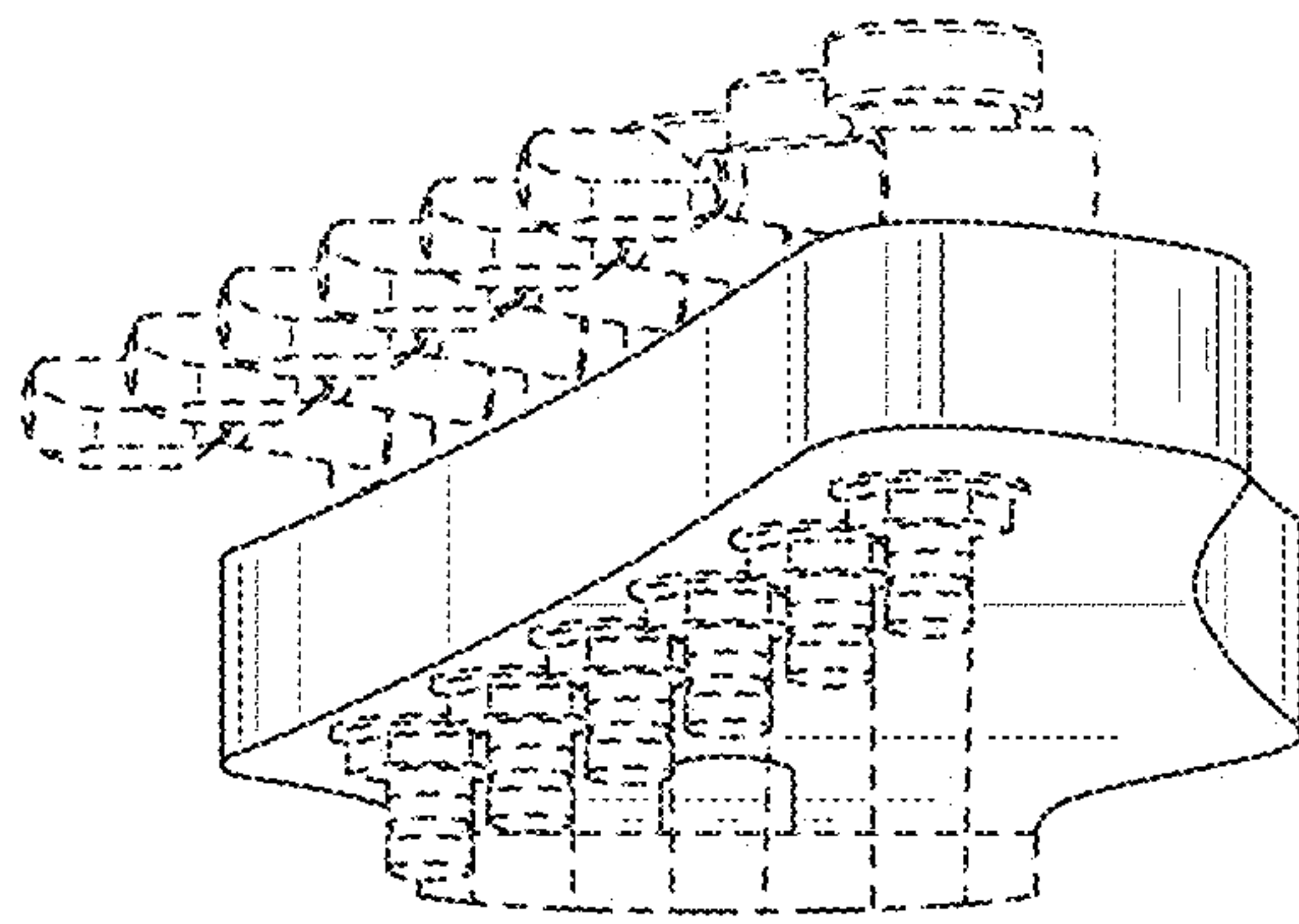

FIG. 6

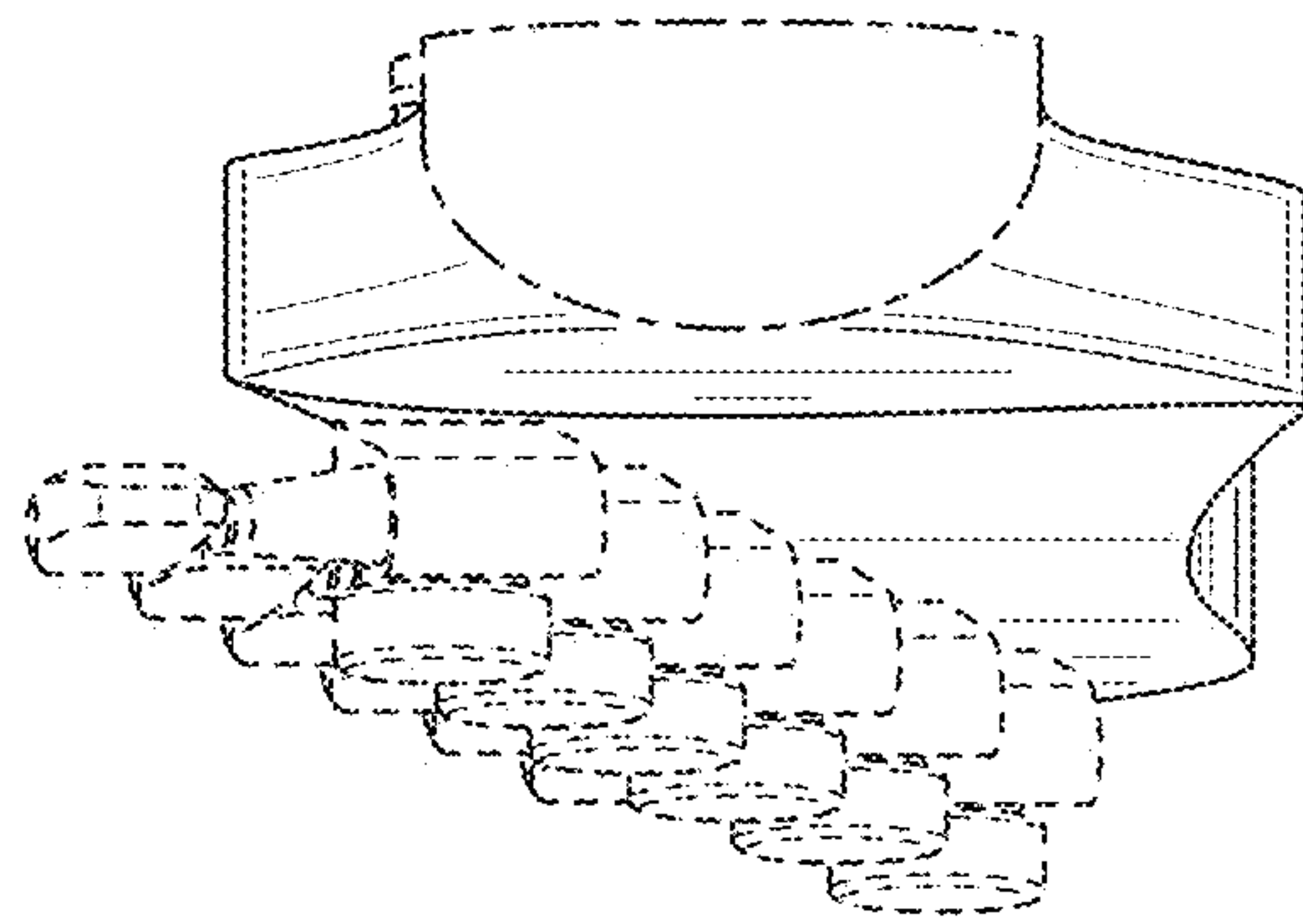

FIG. 7

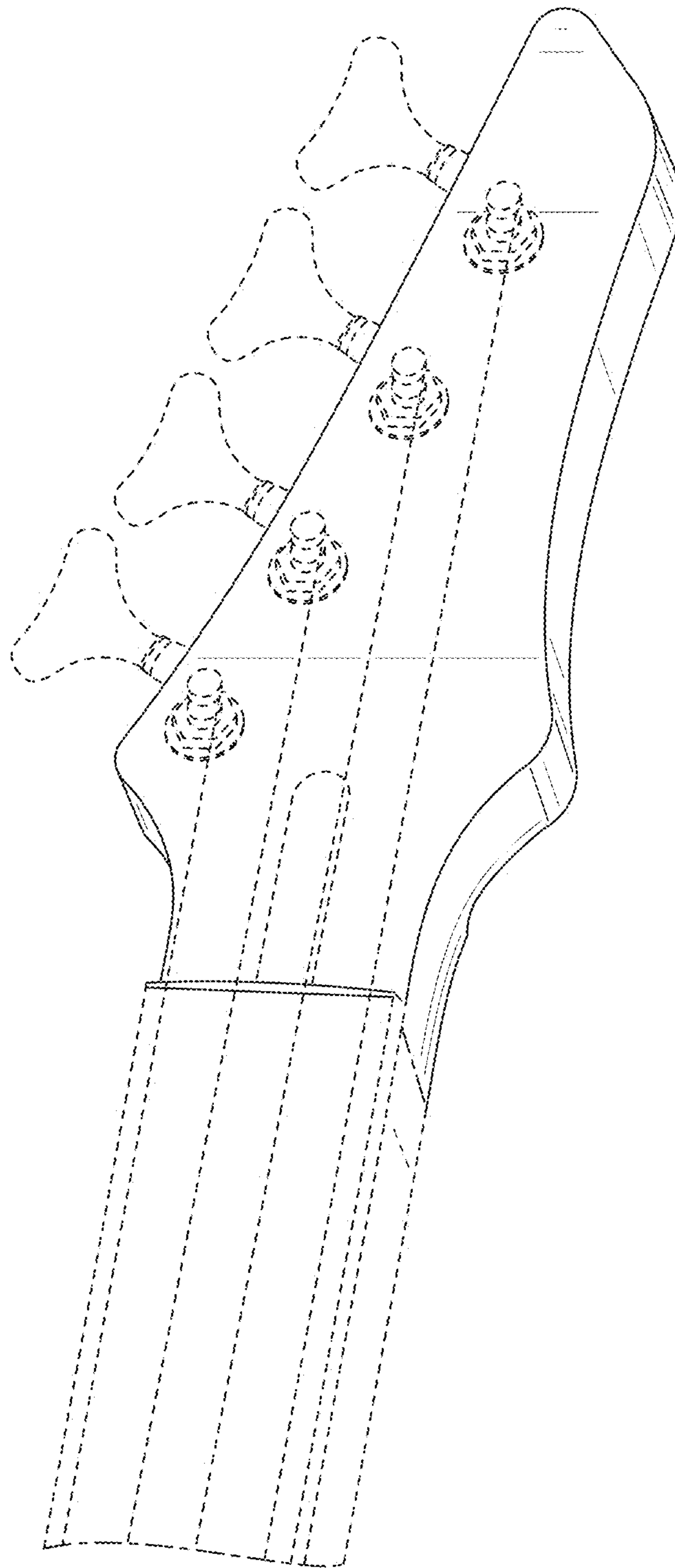

FIG. 8

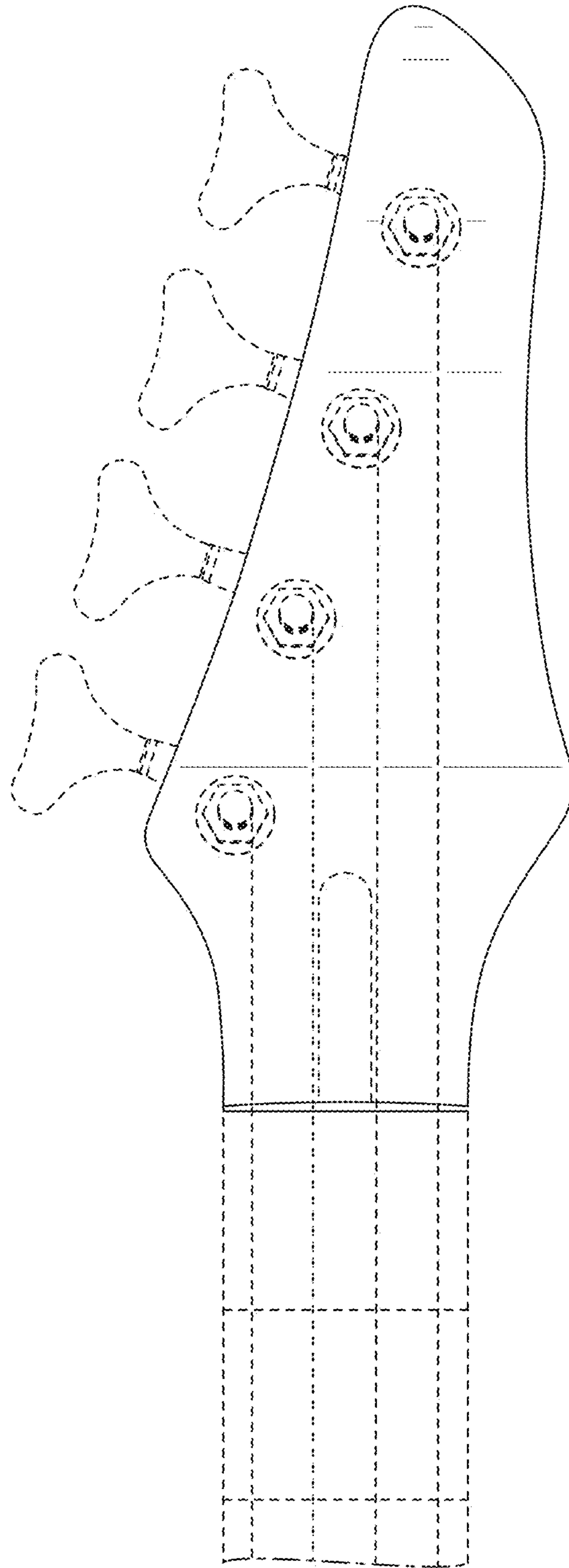

FIG. 9

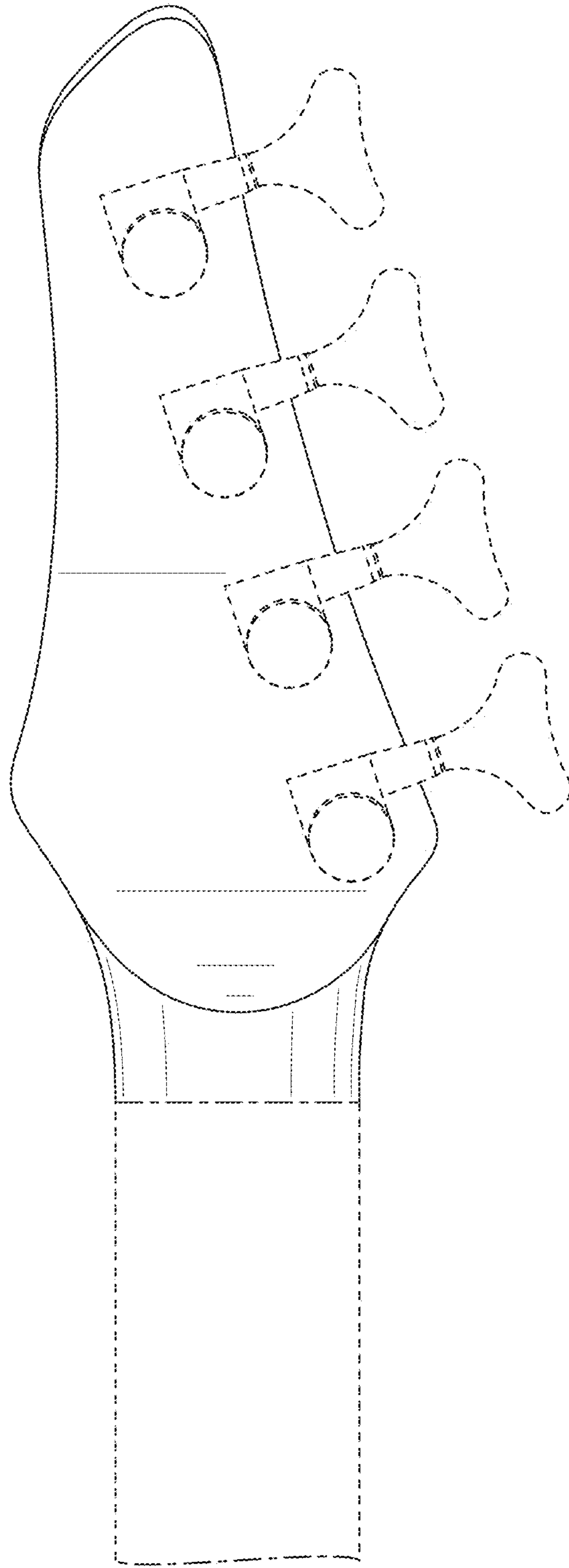

FIG. 10

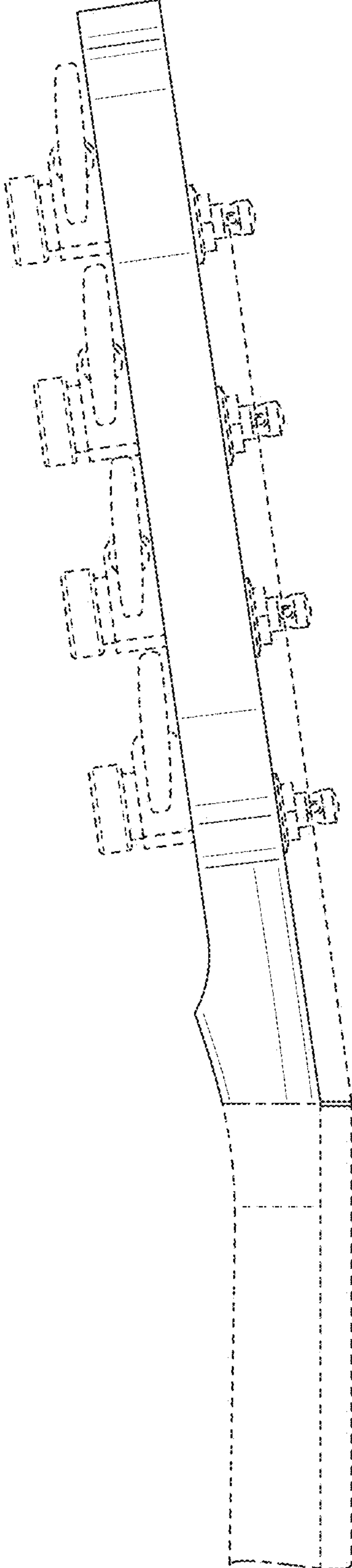

FIG. 11

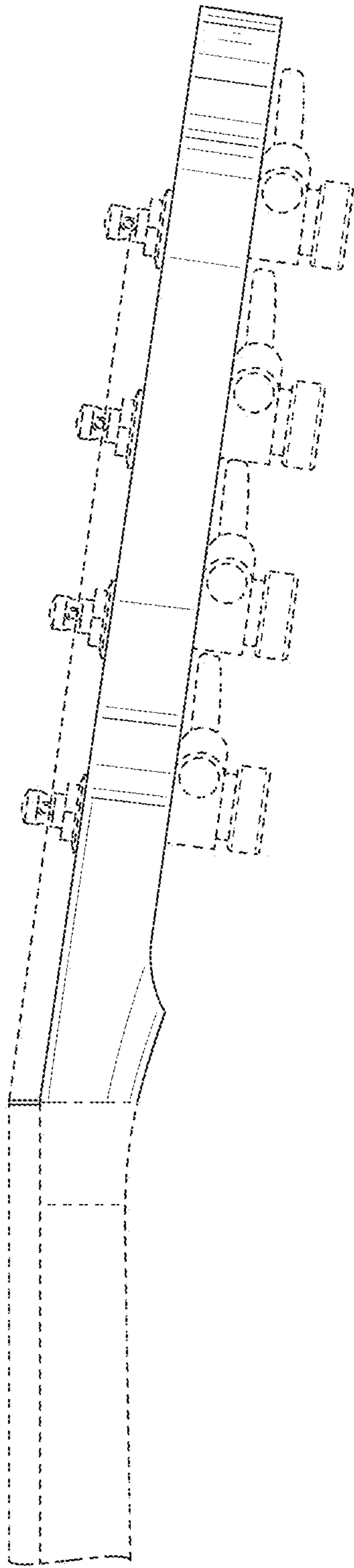

FIG. 12

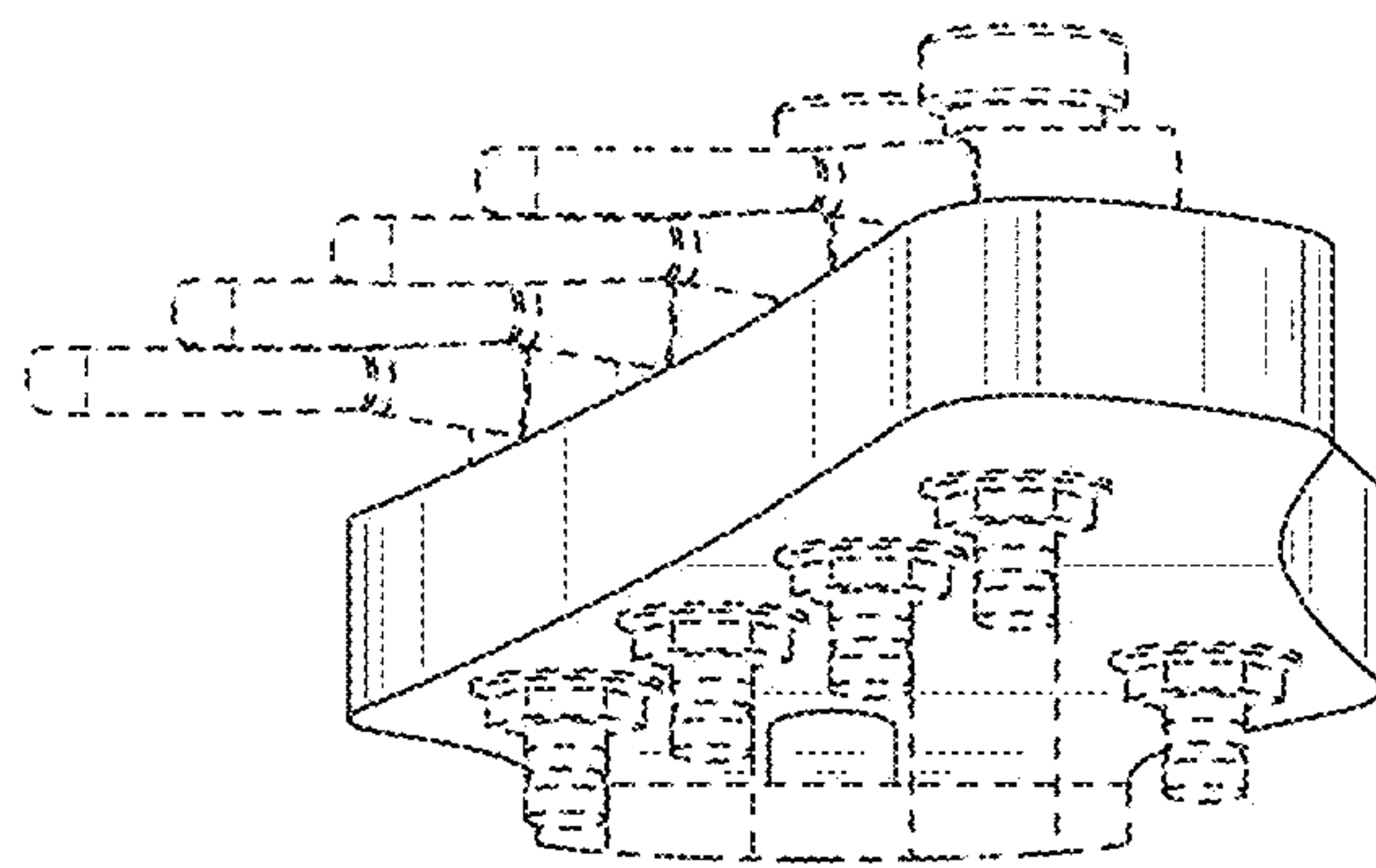

FIG. 13

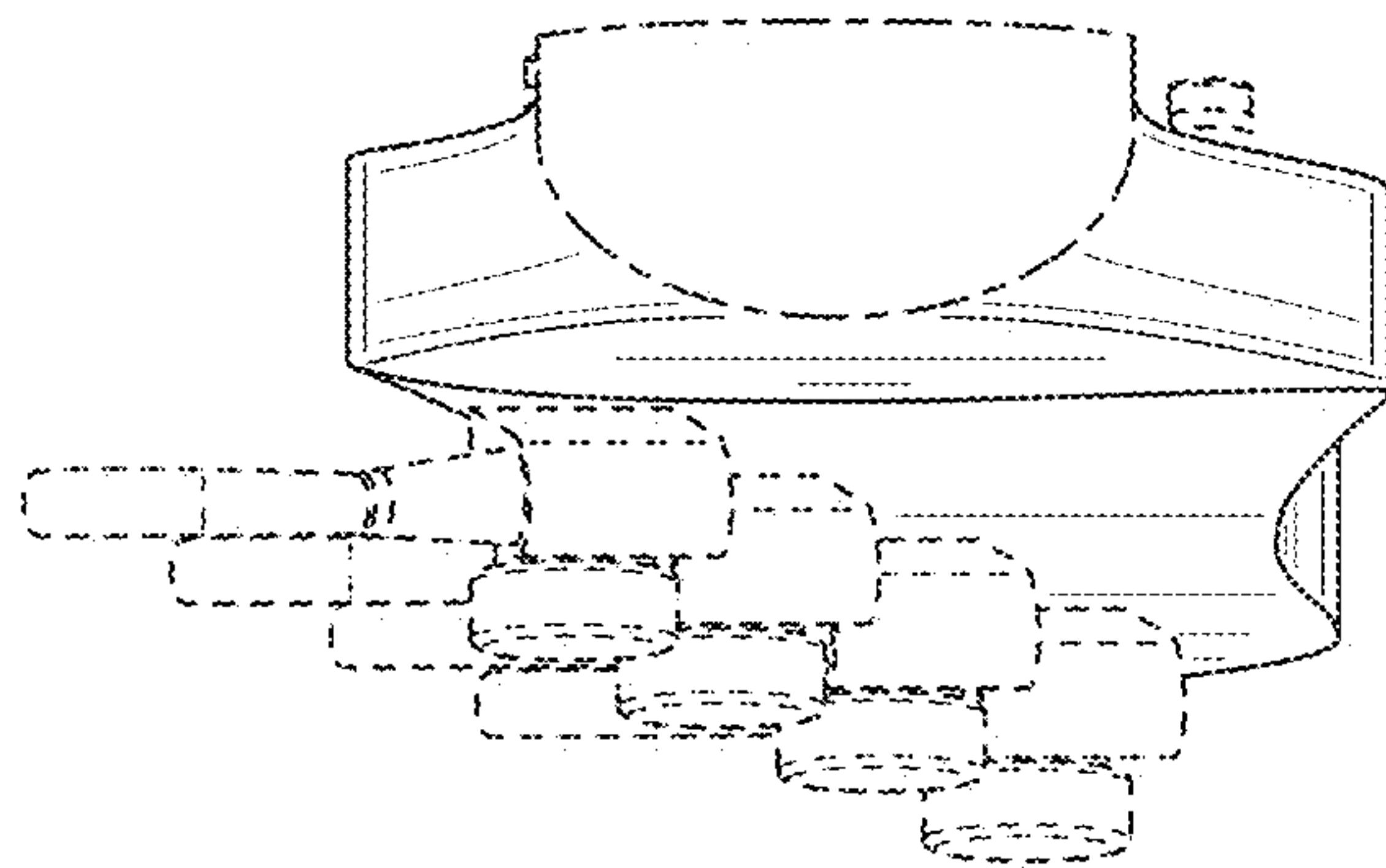

FIG. 14