



US00D888787S

(12) **United States Design Patent**
Kolste et al.

(10) **Patent No.:** **US D888,787 S**
(45) **Date of Patent:** **** Jun. 30, 2020**

- (54) **RADIAL BEARING**
- (71) Applicant: **US SYNTHETIC CORPORATION**,
Orem, UT (US)
- (72) Inventors: **Tyler Kolste**, American Fork, UT (US);
S. Barrett Peterson, Orem, UT (US);
Jair J. Gonzalez, Provo, UT (US);
Trond Pedersen, Bluffdale, UT (US)
- (73) Assignee: **US SYNTHETIC CORPORATION**,
Orem, UT (US)
- (**) Term: **15 Years**
- (21) Appl. No.: **29/606,740**
- (22) Filed: **Jun. 7, 2017**
- (51) **LOC (12) Cl.** **15-03**
- (52) **U.S. Cl.**
USPC **D15/143**
- (58) **Field of Classification Search**
USPC D15/5, 138, 143; D12/400, 159, 161,
D12/206; D8/358, 359, 356; D14/484;
D3/24
CPC B60G 3/20; B60G 2206/122; B60G 7/02;
B60G 2200/156; B60G 2200/18; B60G
2204/143; B60G 7/001; B60G 7/008;
B60G 11/14; B60G 2200/1424; B60G
2200/144; B60G 2200/154; B60G
2204/148; B60G 2204/41; B60G 2500/30;
B60G 3/02; B60G 3/06; B60G 11/27;
B60G 11/48; B60G 13/003; B60G
13/005; B60G 13/16; B60G 15/02; B60G
15/06; B60G 15/062; B60G 15/065;
B60G 15/12; B60G 17/005; B60G
17/0155; B60G 17/016; B60G 17/017;
B60G 17/0272; B60G 17/052; B60G
17/0521; B60G 17/0523; B60G 17/0526;
B60G 21/007; B60G 21/0551; B60G
2200/00; B60G 2200/14; B60G 2200/142;
B60G 2200/17; B60G 2200/46; B60G
2202/12; B60G 2202/135; B60G
2202/152; B60G 2202/24; B60G

2202/242; B60G 2202/31; B60G
2202/312; B60G 2202/314; B60G
2202/412; B60G 2202/413; B60G
2204/1244; B60G 2204/128; B60G
2204/129; B60G 2204/14; B60G
2204/1431; B60G 2204/416; B60G
2204/4302; B60G 2204/44; B60G
2204/61; B60G 2204/82; B60G
2206/0116; B60G 2206/014; B60G
2206/016; B60G 2206/10; B60G 2206/12;
B60G 2206/16; B60G 2206/424; B60G
2206/606; B60G 2206/7101; B60G
2206/7102; B60G 2206/80; B60G
2209/81; B60G 2206/81012; B60G
2206/8102; B60G 2206/811; B60G
2206/82; B60G 2206/8201; B60G
2206/8207; B60G 2206/83; B60G
2206/91; B60G 2300/02; B60G 2300/07;
B60G 2300/122; B60G 2300/124; B60G
2300/13; B60G 2300/402; B60G 2300/45;
B60G 2400/252; B60G 2400/51; B60G
2400/51222; B60G 2400/60; B60G
2401/172; B60G 2500/201; B60G
2800/01; B60G 2800/012; B60G
2800/162; B60G 2800/20; B60G 3/202;
B60G 5/00; B60G 7/00; B60G 7/005

See application file for complete search history.

(56)

References Cited

U.S. PATENT DOCUMENTS

D28,869	S *	6/1898	Perkins	D15/143
D258,828	S *	4/1981	Zrobek	D15/143
D436,117	S *	1/2001	Chuang	D15/143
D443,627	S *	6/2001	West	D15/143
D444,802	S *	7/2001	Dyson	D15/143
6,338,754	B1	1/2002	Cannon et al.		
7,866,418	B2	1/2011	Bertagnolli et al.		
8,236,074	B1	8/2012	Bertagnolli et al.		
8,545,104	B2	10/2013	Sexton et al.		
D699,272	S *	2/2014	Mochizuki	D15/143
8,668,388	B1	3/2014	Peterson		
8,746,979	B2	6/2014	Cooley et al.		
8,995,742	B1	3/2015	Mukhopadhyay et al.		
9,016,405	B2	4/2015	Sexton et al.		
9,062,505	B2	6/2015	Crockett et al.		

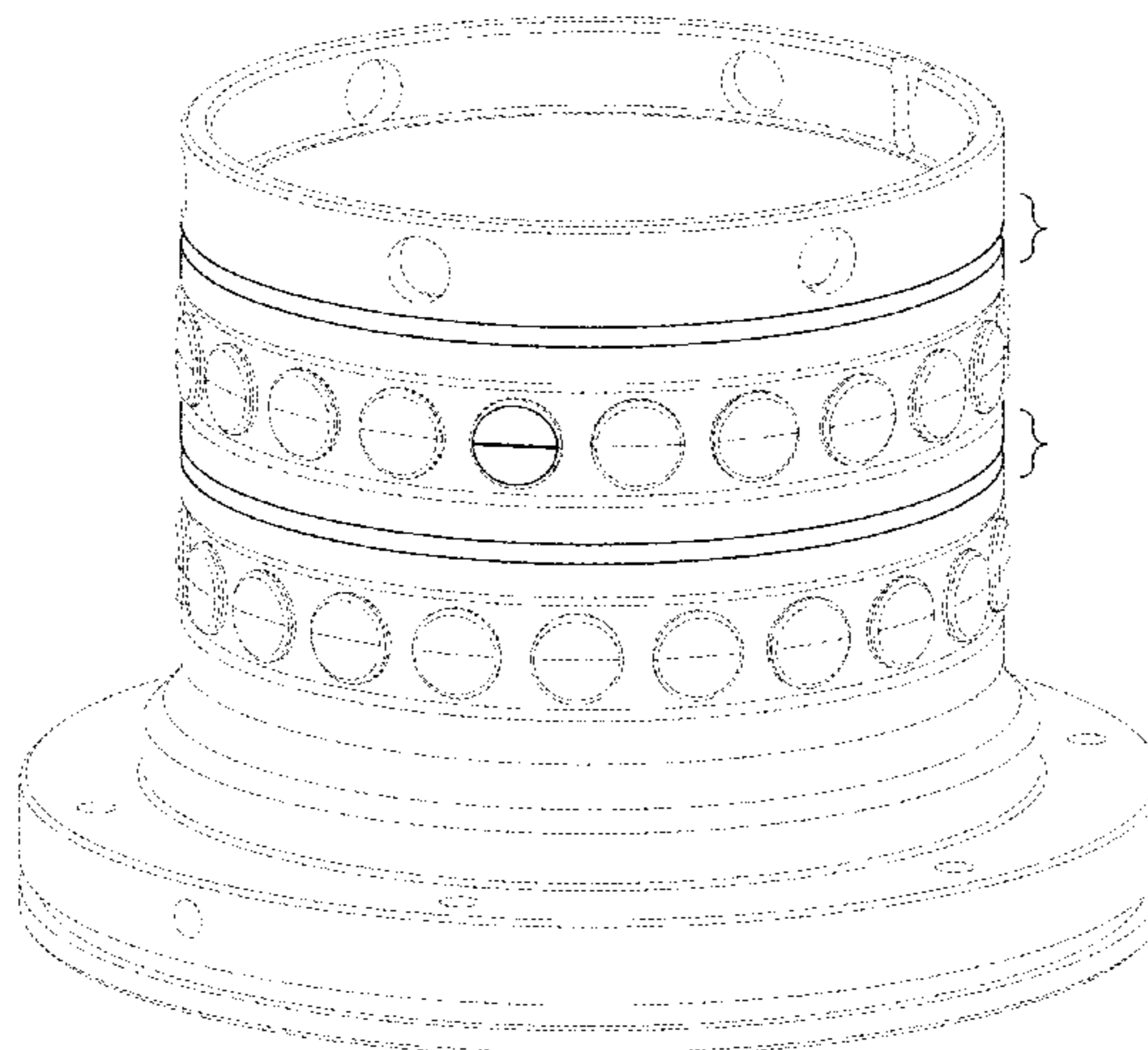

9,062,710	B2 *	6/2015	Lee	F16C 19/381
9,315,881	B2	4/2016	Linford et al.	
9,459,236	B2	10/2016	Bertagnolli et al.	
D770,547	S *	11/2016	Yamamoto	D15/143
D772,964	S *	11/2016	Ban	D15/143
D782,180	S *	3/2017	Eberhard	D3/18
9,664,231	B2 *	5/2017	Omoto	F16C 33/56
9,677,617	B2 *	6/2017	Karlsson	F16C 33/6614
D818,508	S *	5/2018	Ban	D15/143
D824,967	S *	8/2018	Getto	D15/143
D830,435	S *	10/2018	Wakisaka	D15/143
D861,756	S *	10/2019	Pop	D15/143
2003/0026718	A1 *	2/2003	Dziver	F04D 29/047 417/423.9
2008/0112658	A1 *	5/2008	Justin	F16C 17/02 384/107
2009/0260895	A1	10/2009	Vail et al.	
2010/0166347	A1 *	7/2010	Wendling	F16C 33/1075 384/114
2012/0057814	A1	3/2012	Dadson et al.	
2012/0241226	A1	9/2012	Bertagnolli et al.	
2014/0366456	A1	12/2014	Chapman et al.	
2014/0367176	A1	12/2014	Gonzalez et al.	

OTHER PUBLICATIONS

International Search Report and Written Opinion from International Application No. PCT.US2018/03190 dated Jul. 19, 2018.
 U.S. Appl. No. 29/606,797, filed Jun. 7, 2017.
 U.S. Appl. No. 62/279,271, filed Jan. 15, 2016.
 U.S. Appl. No. 62/516,226, filed Jun. 7, 2017.
 Notice of Allowance for U.S. Appl. No. 29/606,797 dated Feb. 19, 2020.

* cited by examiner

Primary Examiner — Khawaja Anwar
 (74) *Attorney, Agent, or Firm* — Dorsey & Whitney LLP

(57) **CLAIM**

The ornamental design for a radial bearing, as shown and described.

DESCRIPTION

FIG. 1 is a perspective view of a radial bearing including a bearing element having a groove in a bearing surface thereof, according to a first embodiment;
 FIG. 2 is a side elevational view of the bearing element shown in FIG. 1, with the opposing side elevational view being identical;
 FIG. 3 is a side elevational view of the bearing element shown in FIG. 1 and rotated 90° relative to the side elevational view shown in FIG. 2, with the opposing side elevational view being identical;
 FIG. 4 is a perspective view of a radial bearing including a plurality of bearing elements that each have a groove in a bearing surface thereof, according to a second embodiment;
 FIG. 5 is a side elevational view of one of the bearing elements shown in FIG. 4, with the opposing side elevational view being identical;
 FIG. 6 is a side elevational view of one of the bearing elements shown in FIG. 4 and rotated 90° relative to the side elevational view shown in FIG. 5, with the opposing side elevational view being identical;
 FIG. 7 is a perspective view of a radial bearing including a plurality of bearing elements that each have a groove in a bearing surface thereof, according to a third embodiment;

FIG. 8 is a side elevational view of one of the bearing elements shown in FIG. 7, with the opposing side elevational view being identical;
 FIG. 9 is a side elevational view of one of the bearing elements shown in FIG. 7 and rotated 90° relative to the side elevational view shown in FIG. 8, with the opposing side elevational view being identical;
 FIG. 10 is a perspective view of a radial bearing including a plurality of bearing elements that each have a groove in a bearing surface thereof, according to a fourth embodiment;
 FIG. 11 is a side elevational view of one of the bearing elements shown in FIG. 10, with the opposing side elevational view being identical;
 FIG. 12 is a side elevational view of one of the bearing elements shown in FIG. 10 and rotated 90° relative to the side elevational view shown in FIG. 11, with the opposing side elevational view being identical;
 FIG. 13 is a perspective view of a radial bearing including a plurality of first bearing elements that each have a groove in a bearing surface thereof and a second bearing element that does not include a groove in a bearing surface thereof, according to a fifth embodiment;
 FIG. 14 is a side elevational view of one of the first bearing elements shown in FIG. 13, with the opposing side elevational view being identical;
 FIG. 15 is a side elevational view of one of the first bearing elements shown in FIG. 13 and rotated 90° relative to the side elevational view shown in FIG. 14, with the opposing side elevational view being identical;
 FIG. 16 is a side elevational view of the second bearing element shown in FIG. 13, with the opposing side elevational view being identical;
 FIG. 17 is a side elevational view of the second bearing element shown in FIG. 13 and rotated 90° relative to the side elevational view shown in FIG. 16, with the opposing side elevational view being identical;
 FIG. 18 is a perspective view of a radial bearing including a plurality of first bearing elements that each have a groove in a bearing surface thereof and a plurality of second bearing elements that do not include a groove in a bearing surface thereof, according to a sixth embodiment;
 FIG. 19 is a side elevational view of one of the first bearing elements shown in FIG. 18, with the opposing side elevational view being identical;
 FIG. 20 is a side elevational view of one of the first bearing elements shown in FIG. 18 and rotated 90° relative to the side elevational view shown in FIG. 19, with the opposing side elevational view being identical;
 FIG. 21 is a side elevational view of one of the second bearing elements shown in FIG. 18, with the opposing side elevational view being identical;
 FIG. 22 is a side elevational view of one of the second bearing elements shown in FIG. 18 and rotated 90° relative to the side elevational view shown in FIG. 21, with the opposing side elevational view being identical;
 FIG. 23 is a perspective view of a radial bearing including a plurality of bearing elements that each have a groove in a bearing surface thereof, according to a seventh embodiment;
 FIG. 24 is a side elevational view of one of the bearing elements shown in FIG. 23, with the opposing side elevational view being identical;
 FIG. 25 is a side elevational view of one of the bearing elements shown in FIG. 23 and rotated 90° relative to the side elevational view shown in FIG. 24, with the opposing side elevational view being identical;

FIG. 26 is a perspective view of a radial bearing including a plurality of bearing elements that each have a groove in a bearing surface thereof, according to a eighth embodiment; FIG. 27 is a side elevational view of one of the bearing elements shown in FIG. 26, with the opposing side elevational view being identical; and, FIG. 28 is a side elevational view of one of the bearing elements shown in FIG. 26 and rotated 90° relative to the side elevational view shown in FIG. 27, with the opposing side elevational view being identical. The broken lines shown in the drawings are for illustrative purposes only and form no part of the claimed design.

1 Claim, 18 Drawing Sheets

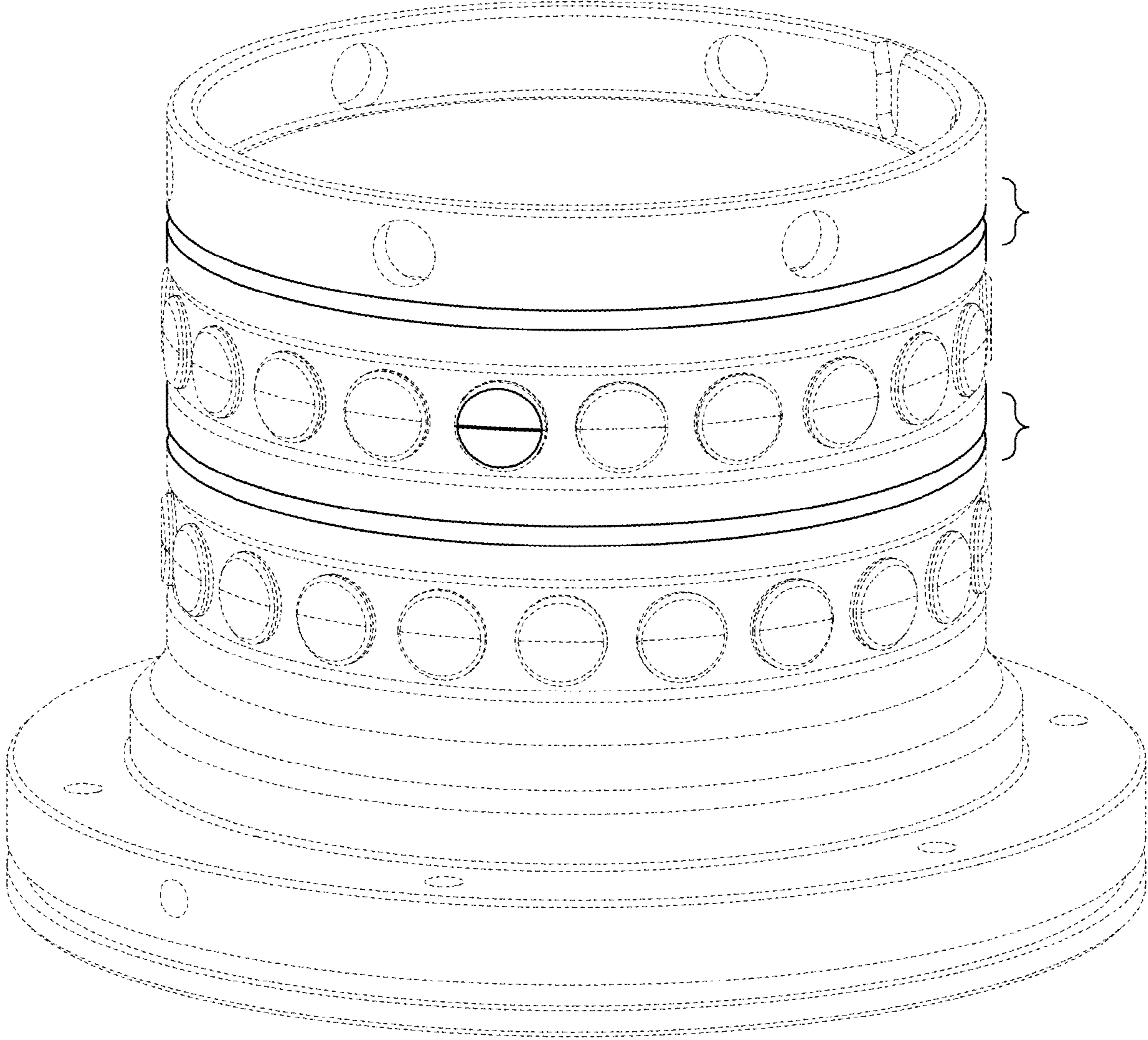

FIG. 1

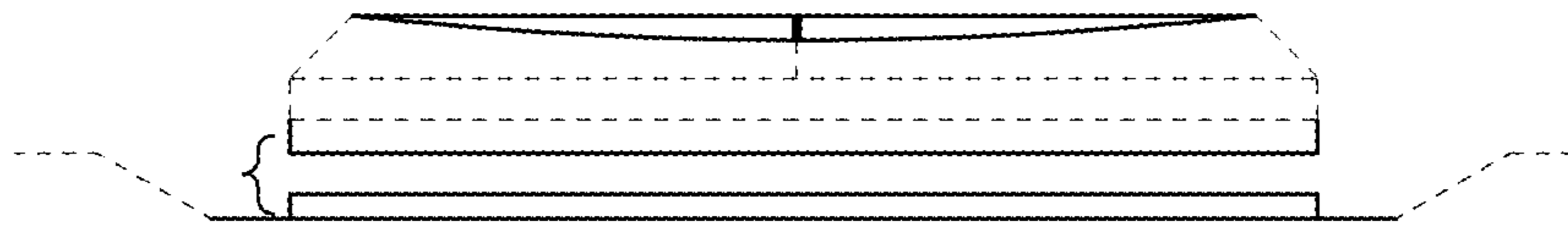

FIG. 2

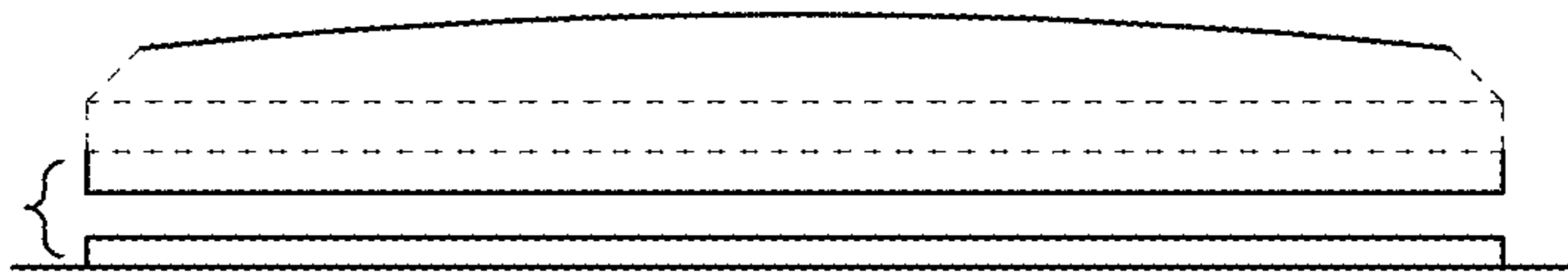

FIG. 3

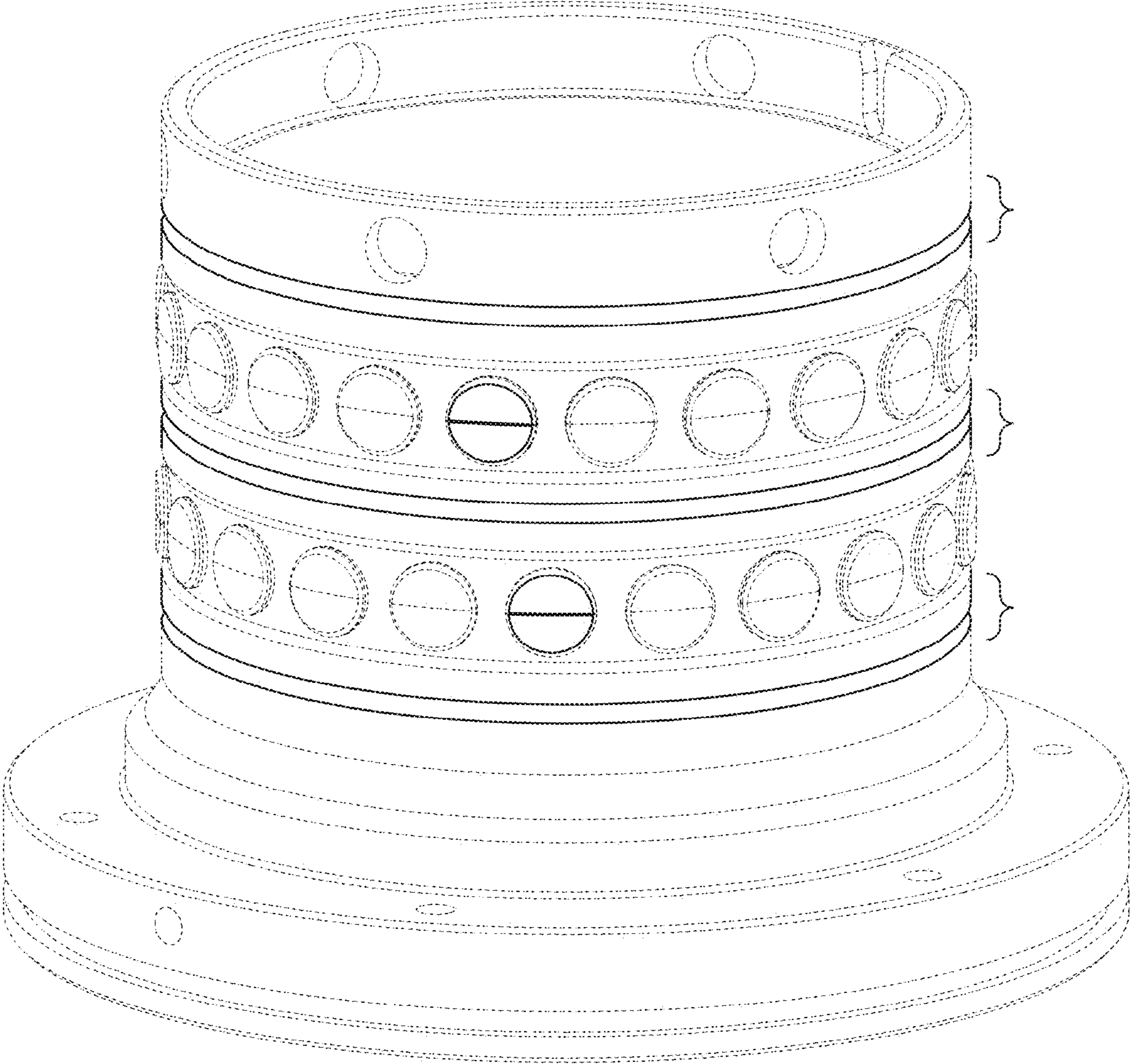

FIG. 4

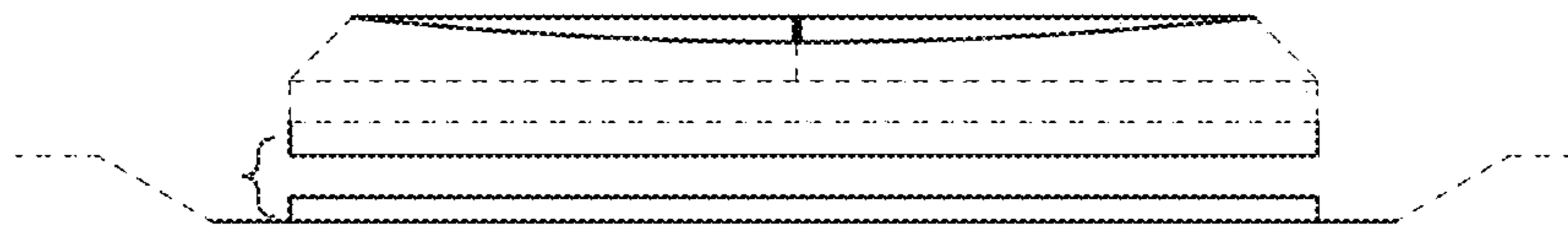

FIG. 5

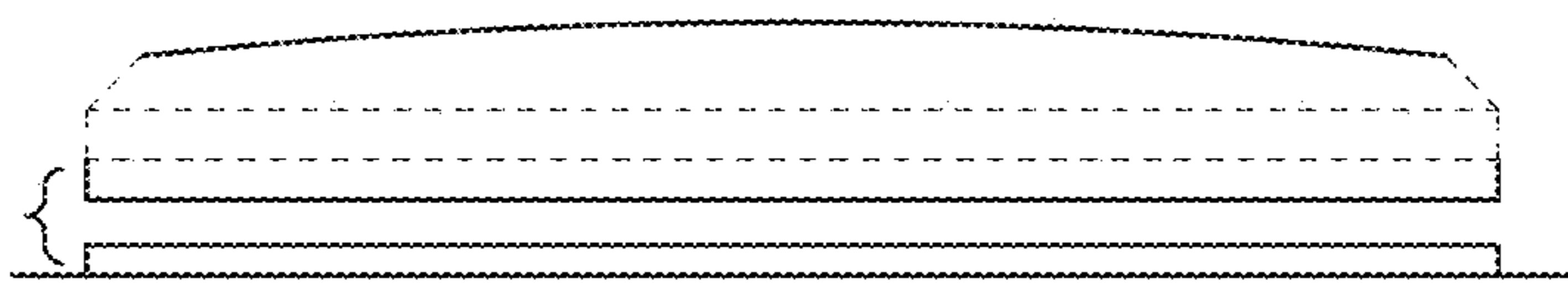

FIG. 6

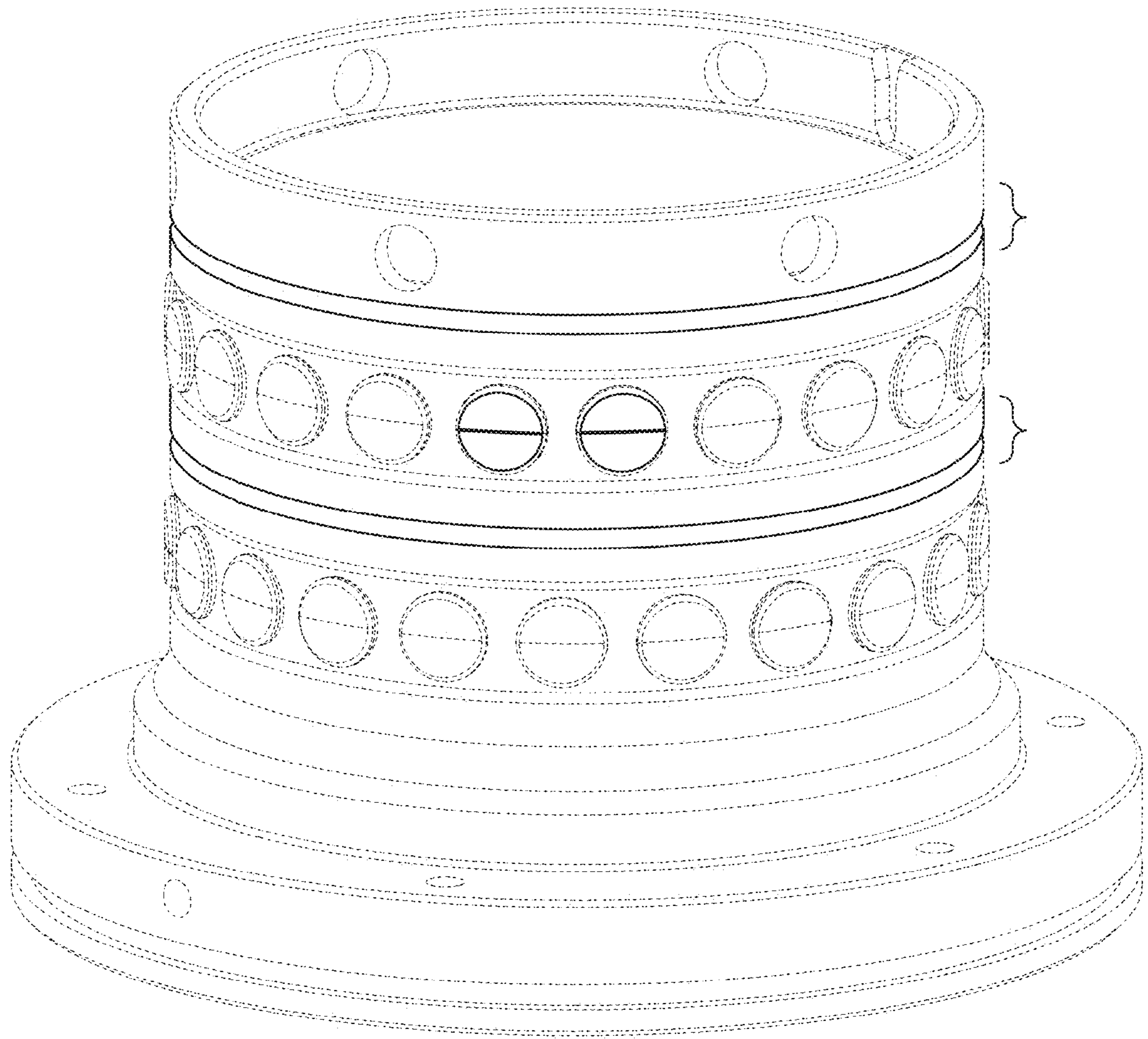

FIG. 7

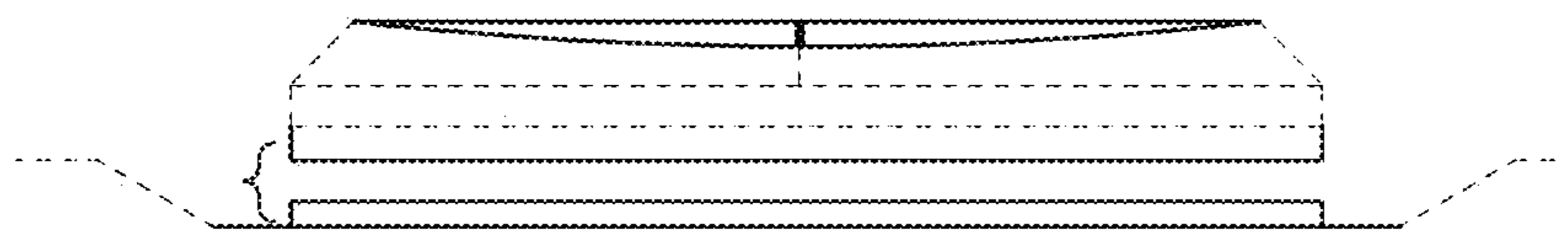

FIG. 8

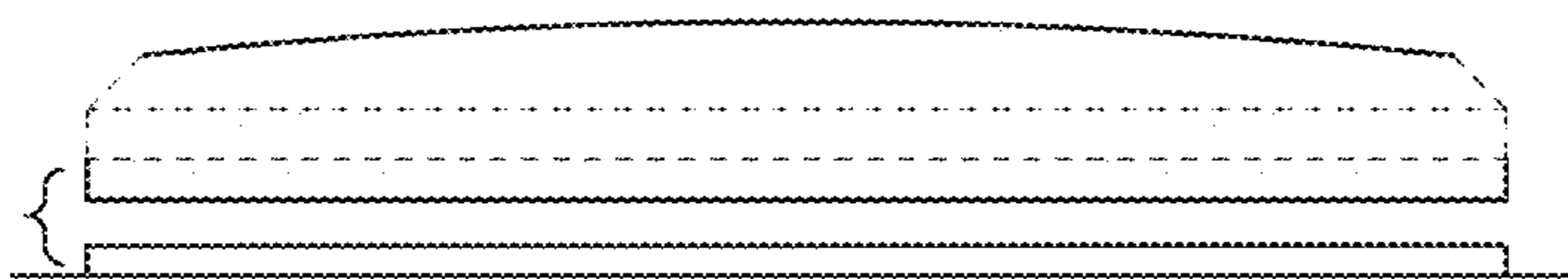

FIG. 9

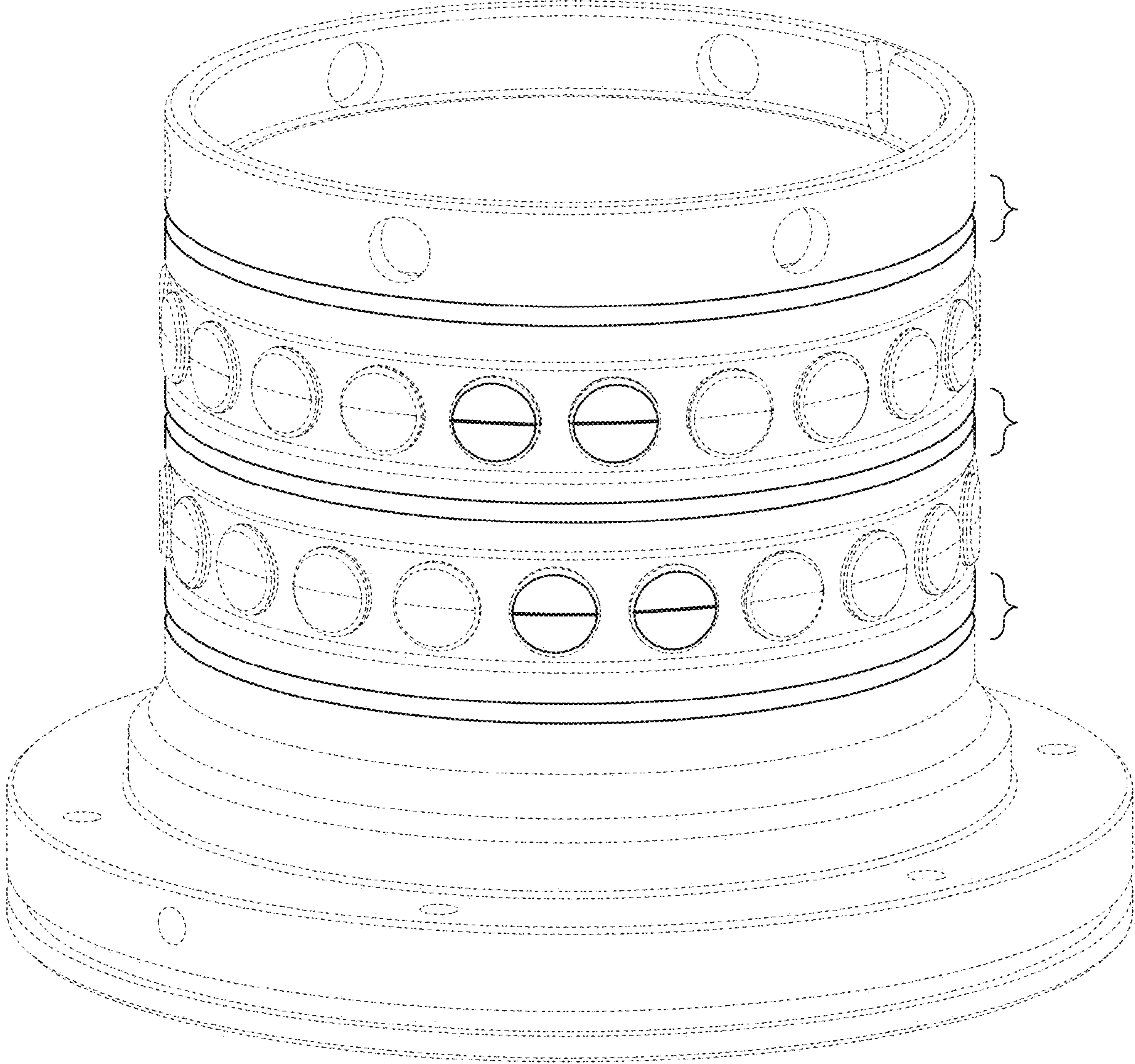

FIG. 10

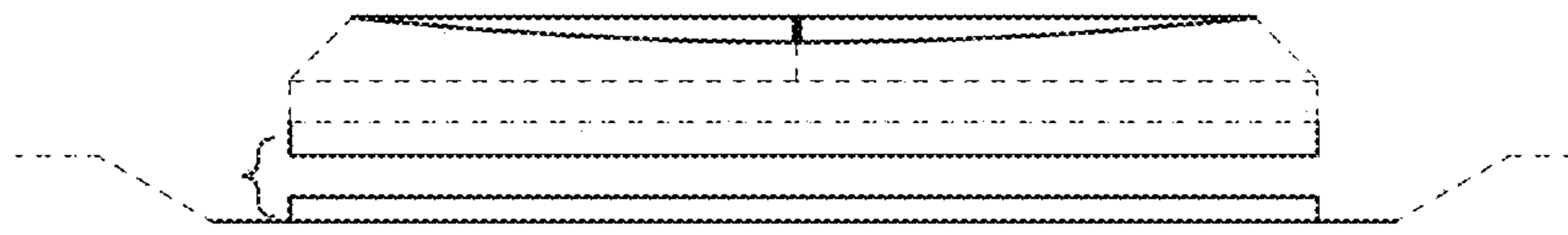

FIG. 11

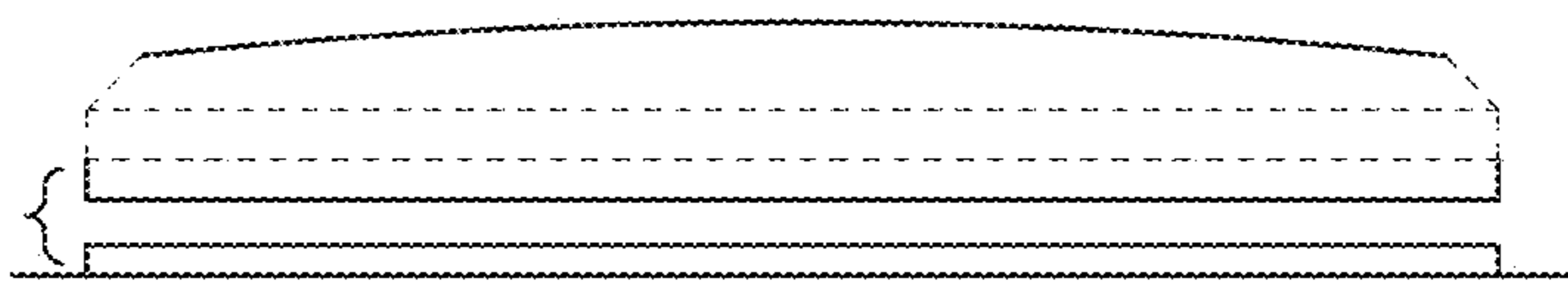

FIG. 12

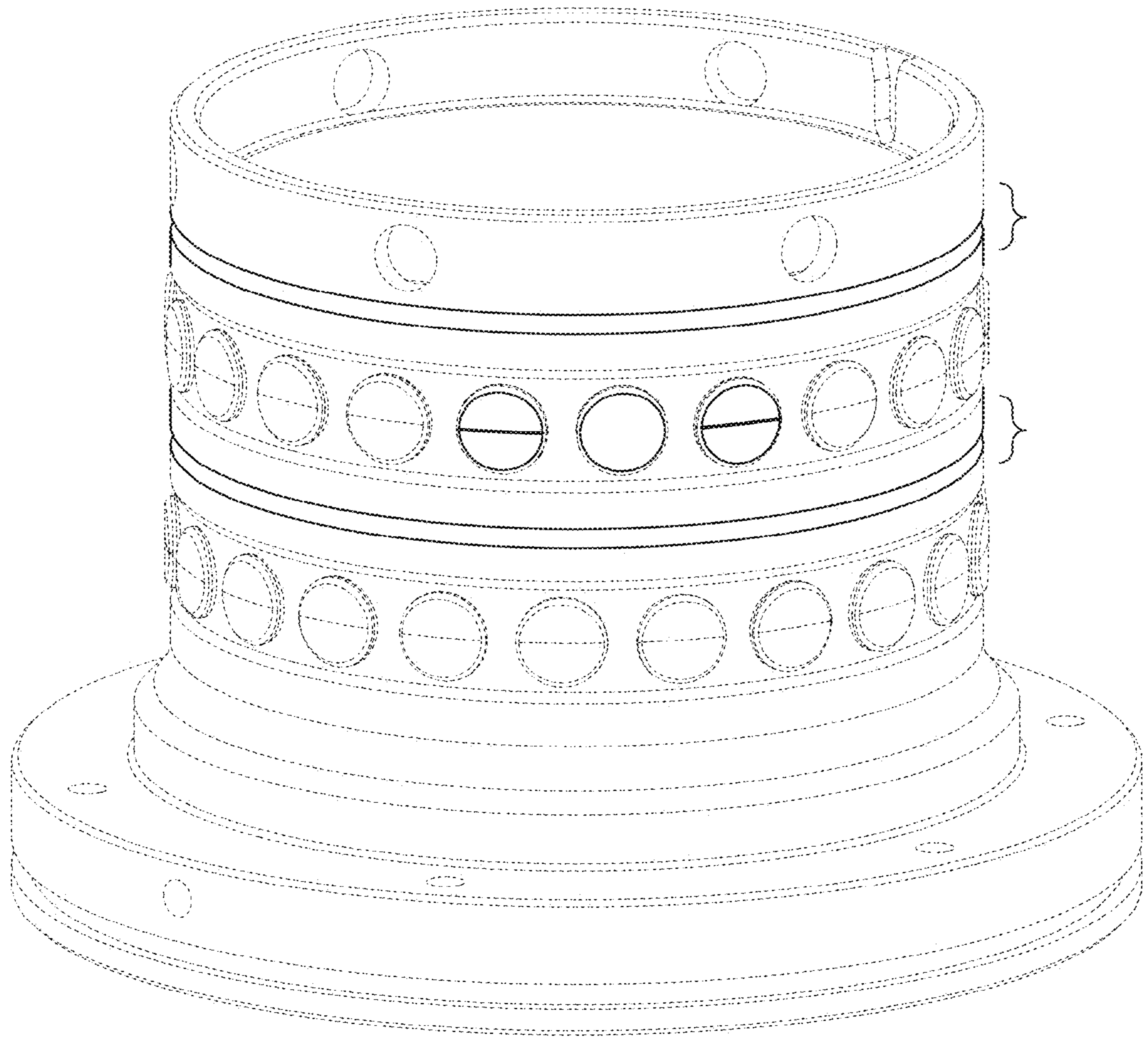

FIG. 13

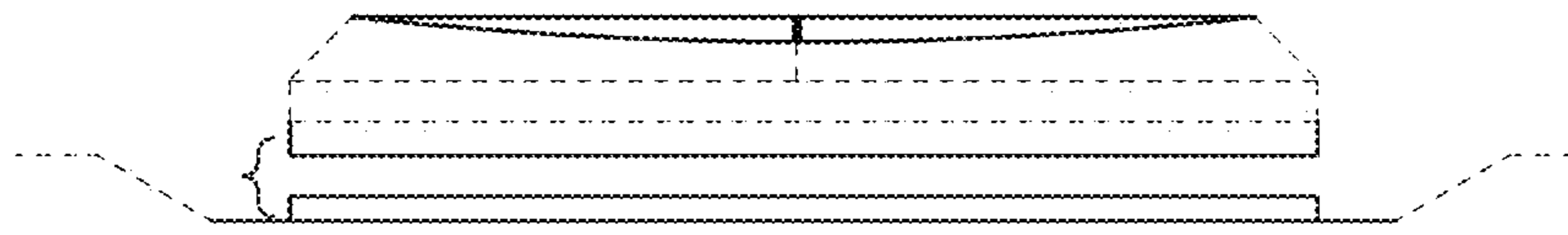

FIG. 14

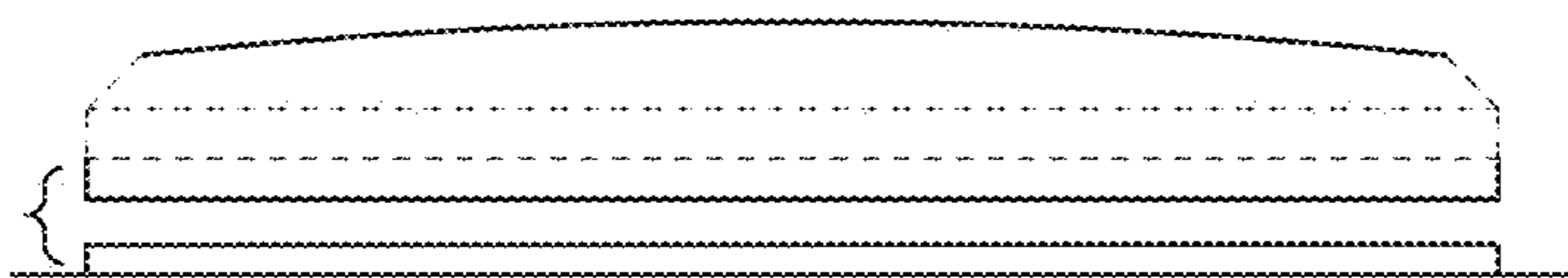

FIG. 15

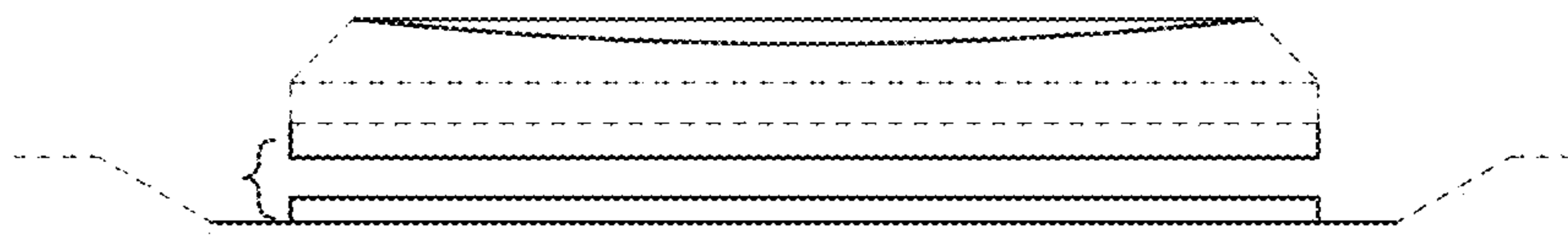

FIG. 16

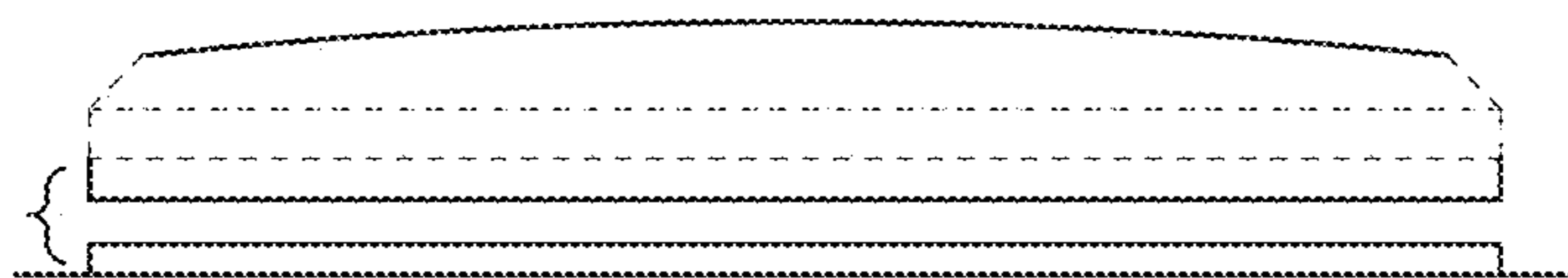

FIG. 17

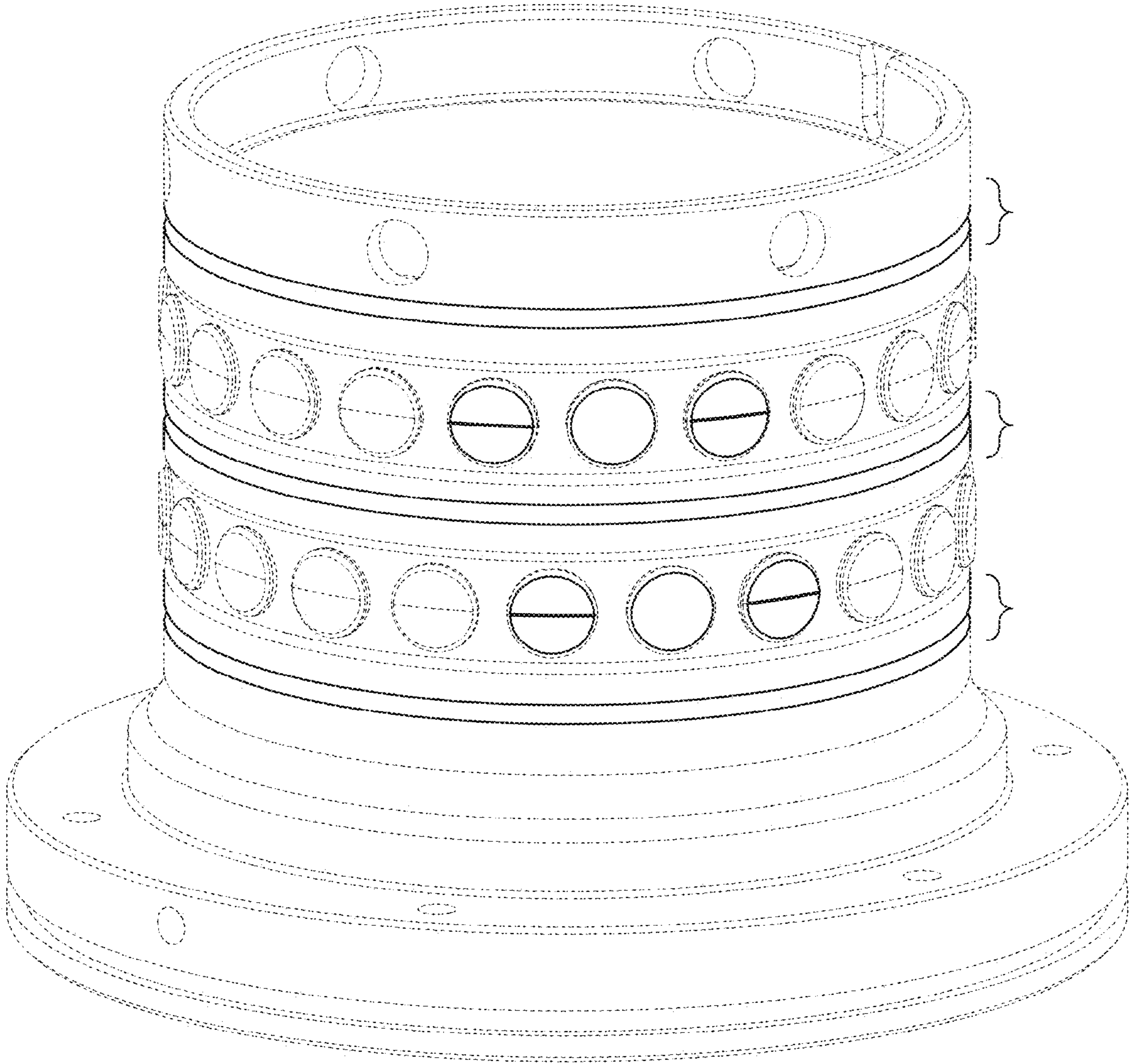

FIG. 18

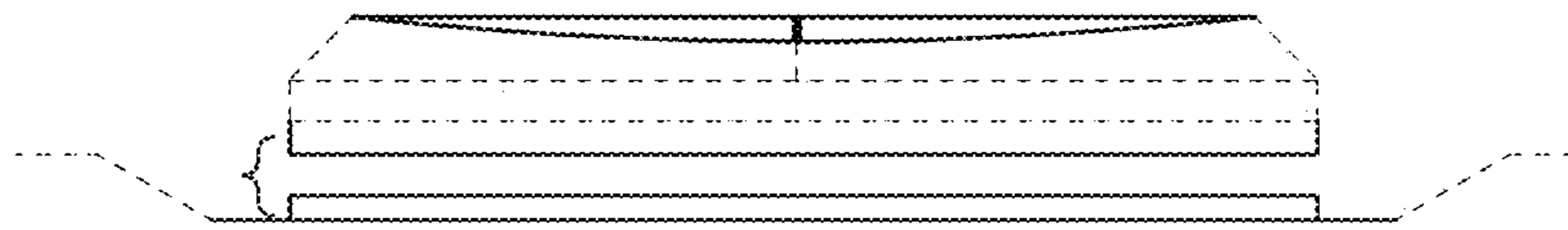

FIG. 19

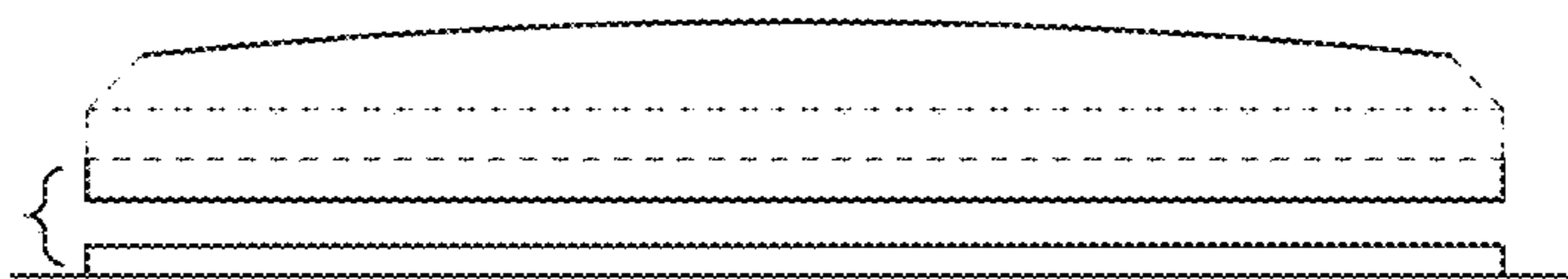

FIG. 20

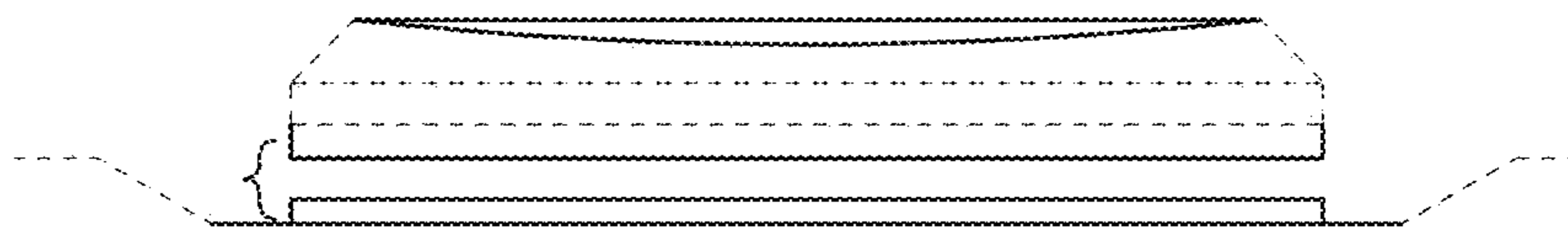

FIG. 21

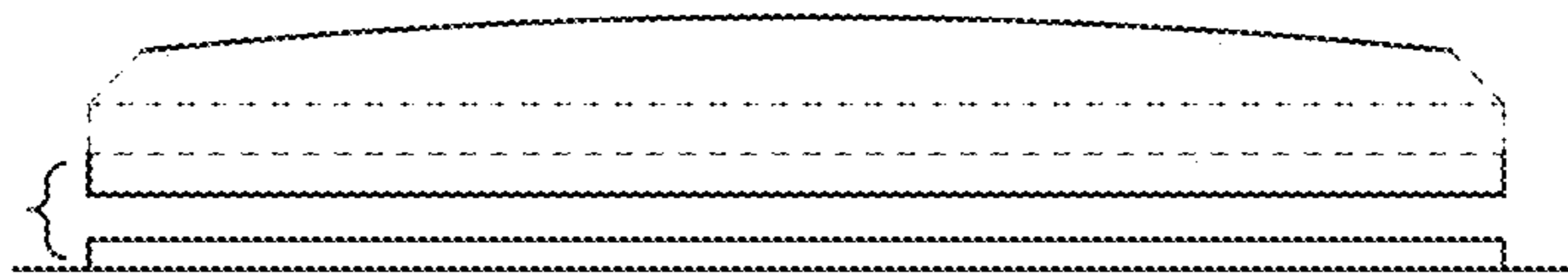

FIG. 22

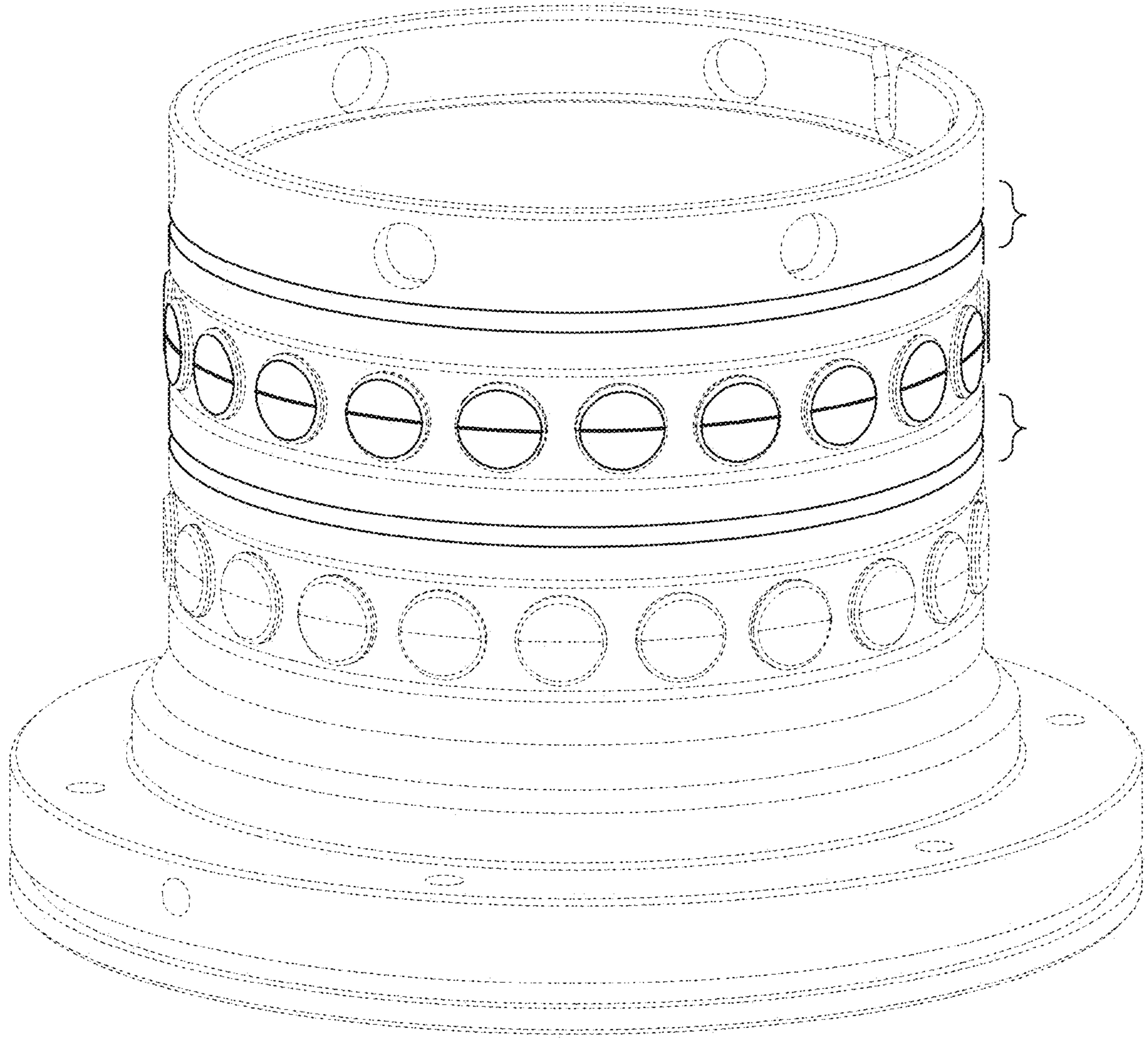

FIG. 23

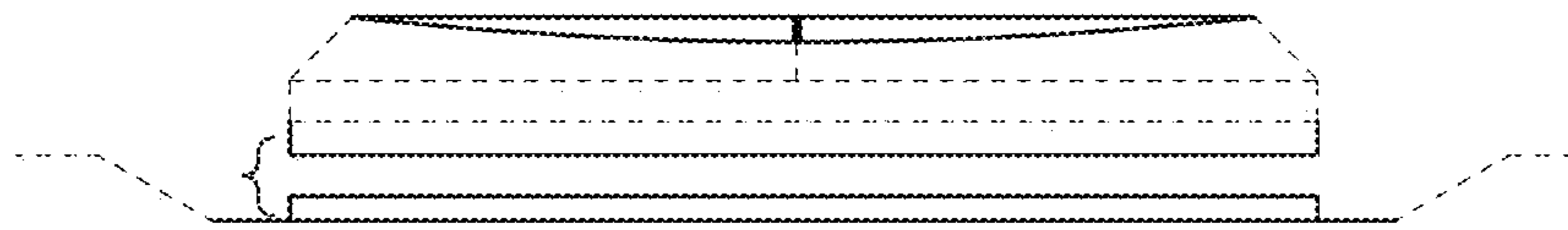

FIG. 24

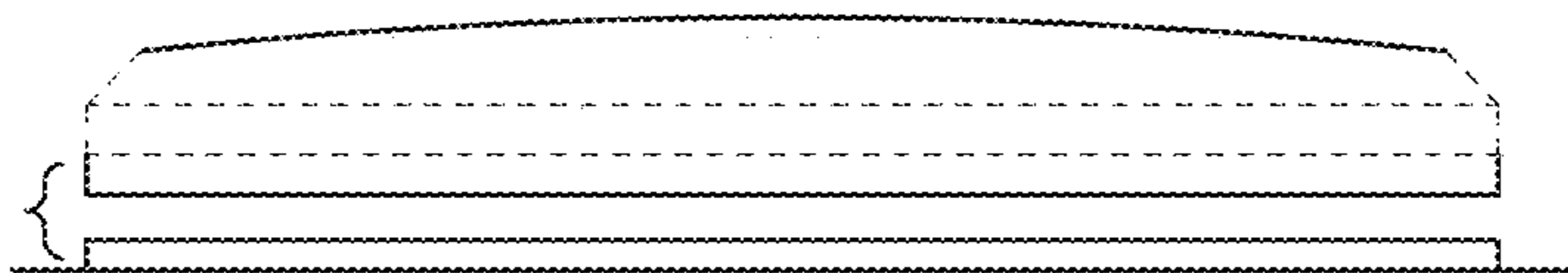

FIG. 25

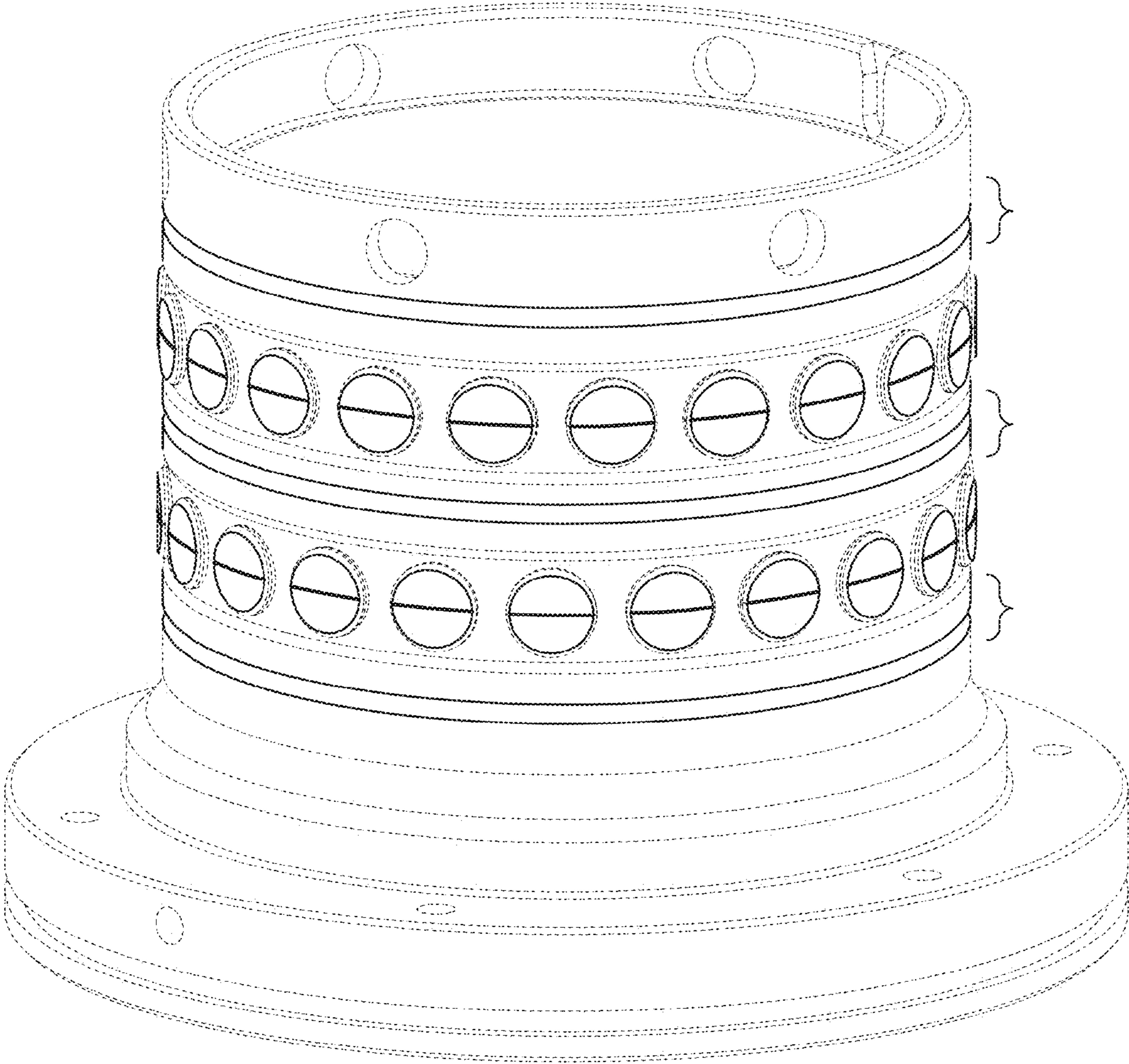

FIG. 26

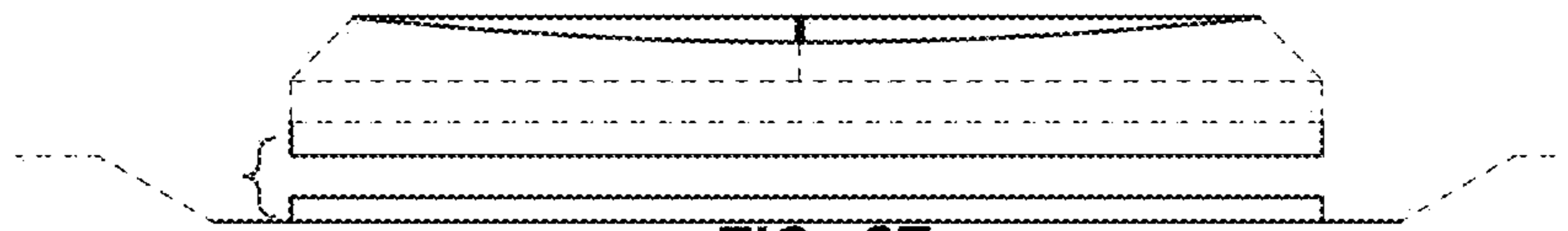

FIG. 27

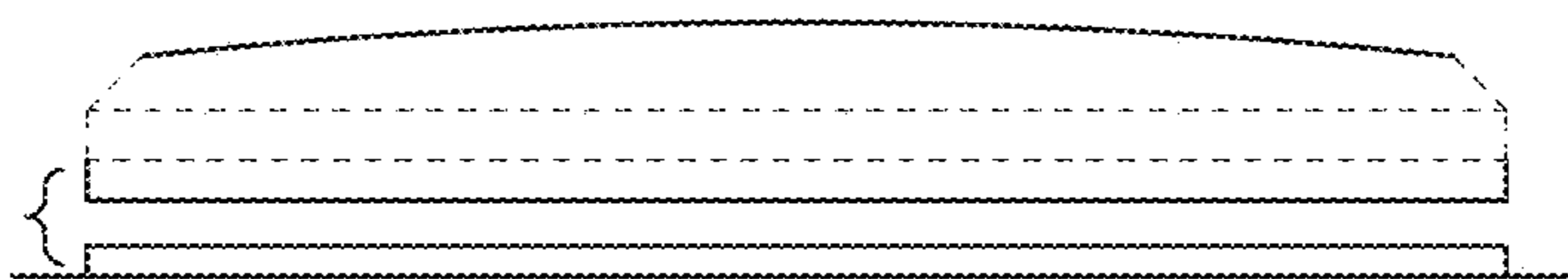

FIG. 28