



US00D888785S

(12) **United States Design Patent**
Sinn et al.

(10) **Patent No.:** **US D888,785 S**
(45) **Date of Patent:** **** Jun. 30, 2020**

(54) **ADAPTER FOR A GROUND ENGAGING MACHINE IMPLEMENT**

3,079,710 A 3/1963 Larsen et al.
3,312,004 A 4/1967 Johnson
3,623,247 A 11/1971 Stepe
3,774,324 A 11/1973 Lafond
3,823,496 A 7/1974 Querci et al.

(71) Applicant: **Caterpillar Inc.**, Deerfield, IL (US)

(Continued)

(72) Inventors: **Eric Sinn**, Tremont, IL (US); **Douglas Serrurier**, Morton, IL (US); **Rammagy Yoeu**, Dunlap, IL (US)

FOREIGN PATENT DOCUMENTS

(73) Assignee: **Caterpillar Inc.**, Peoria, IL (US)

CL 2068-1995 10/1996
CL 391-1998 11/1998

(**) Term: **15 Years**

(Continued)

(21) Appl. No.: **29/682,767**

OTHER PUBLICATIONS

(22) Filed: **Mar. 7, 2019**

Caterpillar Inc., Cat® K Series™ Tooth Systems, brochure (4 pages), 2006.

(51) **LOC (12) Cl.** **15-03**

(Continued)

(52) **U.S. Cl.**

USPC **D15/29**; D15/28

(58) **Field of Classification Search**

USPC D15/11, 28, 29; 37/456, 452, 450, 446, 37/454, 449, 453, 455, 903; 403/379.5, 403/DIG. 1; 111/152; 172/724, 730, 172/766, 770, 771, 721, 713, 699, 772
CPC Y10T 29/49826; Y10T 403/589; Y10T 403/7018; Y10T 403/7075; E02F 9/28; E02F 9/2825; E02F 9/2833; E02F 9/2866; E02F 9/2858; E02F 9/2808; E02F 9/2841

See application file for complete search history.

Primary Examiner — Mark A Goodwin

(74) *Attorney, Agent, or Firm* — Saidman Design Law Group

(57) **CLAIM**

The ornamental design for an adapter for a ground engaging machine implement, as shown and described.

DESCRIPTION

FIG. 1 is a front perspective view of an adapter for a ground engaging machine implement showing our new design; FIG. 2 is a front view thereof; FIG. 3 is a rear view thereof; FIG. 4 is a left side view thereof; FIG. 5 is a right side view thereof; FIG. 6 is a top view thereof; and, FIG. 7 is a bottom view thereof. Grayscale shading illustrates contour. The broken lines illustrate structure or features which form no part of the claimed design.

(56) **References Cited**

U.S. PATENT DOCUMENTS

1,220,186 A 3/1917 Chambers
1,384,701 A 7/1921 McMonegal
1,571,782 A 2/1926 Andrews
1,856,930 A 5/1932 Robin
2,256,488 A 9/1941 Murtaugh
2,427,651 A 9/1947 Baer
D182,143 S 2/1958 Petersen
2,982,035 A 5/1961 Stephenson
3,019,537 A 2/1962 Stephenson

1 Claim, 5 Drawing Sheets

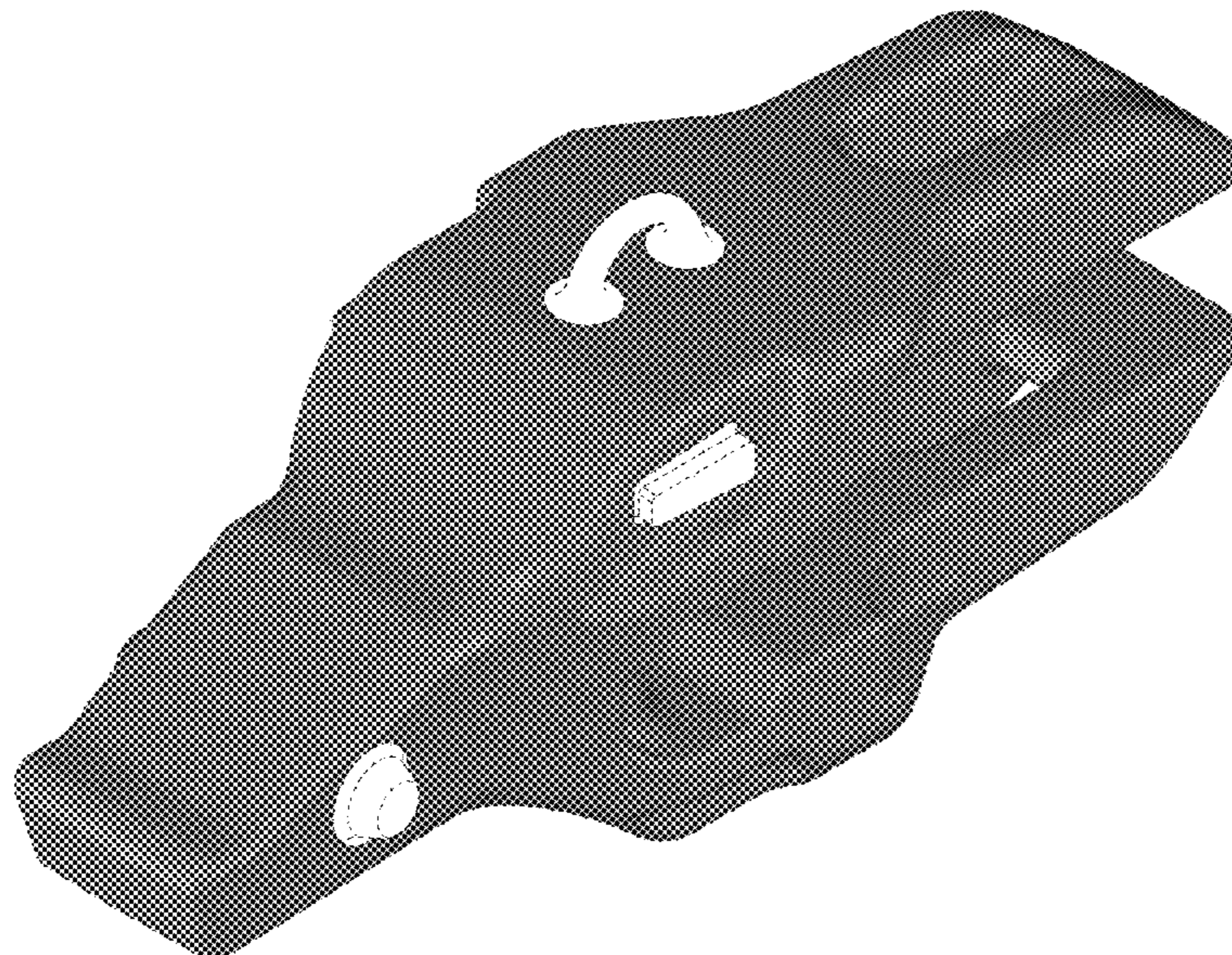

(56)

References Cited

U.S. PATENT DOCUMENTS

3,832,077	A	8/1974	Von Mehren	8,122,621	B2	2/2012	Carpenter et al.	
4,027,408	A	6/1977	Ramella et al.	8,191,291	B2	6/2012	Vanderpoorten et al.	
D251,431	S	3/1979	Klett et al.	8,356,432	B2	1/2013	Carpenter	
D252,461	S	7/1979	Korpi	D706,307	S	6/2014	Renski et al.	
4,182,057	A	1/1980	Klett et al.	D706,311	S	6/2014	Renski et al.	
D255,119	S	5/1980	Korpi	D706,312	S	6/2014	Renski et al.	
4,231,173	A	11/1980	Davis	D706,839	S	6/2014	Renski et al.	
4,335,532	A	6/1982	Hahn et al.	D706,840	S	6/2014	Renski et al.	
D275,859	S	10/1984	Nilsson	D707,263	S	6/2014	Renski et al.	
4,481,728	A	11/1984	Mulder et al.	D707,264	S	6/2014	Renski et al.	
4,516,340	A	5/1985	Lauder	8,943,717	B2	2/2015	Renski et al.	
D296,442	S	6/1988	Broomhall	D727,367	S	4/2015	Renski et al.	
4,761,900	A	8/1988	Emrich	D727,368	S	4/2015	Renski et al.	
4,776,113	A	10/1988	Bedford et al.	D727,369	S	4/2015	Renski et al.	
4,848,013	A	7/1989	Bowman et al.	D727,979	S	4/2015	Renski et al.	
4,932,145	A	6/1990	Reeves	D727,980	S	4/2015	Renski et al.	
4,949,481	A	8/1990	Fellner	D727,981	S	4/2015	Renski et al.	
4,965,945	A	10/1990	Emrich	D727,982	S	4/2015	Renski et al.	
4,980,980	A	1/1991	Schadov et al.	D728,635	S	5/2015	Kunz	
5,018,283	A	5/1991	Fellner	D728,636	S	5/2015	Kunz	
5,144,762	A	9/1992	Robinson	D728,637	S	5/2015	Kunz	
D336,476	S	6/1993	Garman	9,057,177	B2	6/2015	Renski et al.	
D339,592	S	9/1993	Johansson	9,062,436	B2	6/2015	Renski et al.	
D345,364	S	3/1994	Robinson	9,222,243	B2	12/2015	Cheyne et al.	
D352,044	S	11/1994	Hahn	D748,679	S	2/2016	Renski et al.	
5,423,138	A	6/1995	Livesay et al.	D748,681	S	2/2016	Renski et al.	
D365,577	S	12/1995	Ruvang	D748,682	S	2/2016	Renski et al.	
5,561,925	A	10/1996	Livesay	D748,684	S	2/2016	Renski et al.	
5,666,748	A	9/1997	Emrich et al.	D748,685	S	2/2016	Kunz	
D385,286	S	10/1997	Moreno	D749,146	S	2/2016	Renski et al.	
5,709,043	A	1/1998	Jones et al.	D749,147	S	2/2016	Kunz	
D391,583	S	3/1998	Moreno	D761,883	S	7/2016	Kunz	
D392,292	S	3/1998	Moreno	D769,946	S	10/2016	Kunz	
D395,661	S	6/1998	Moreno	D774,108	S	12/2016	Balan et al.	
5,806,216	A	9/1998	Renski	D774,109	S	12/2016	Balan et al.	
D399,511	S	10/1998	Lauder et al.	D774,110	S	12/2016	Balan et al.	
5,852,888	A	12/1998	Cornelius	D774,564	S	12/2016	Balan et al.	
D408,422	S	4/1999	Moreno	D774,565	S	12/2016	Balan et al.	
D410,657	S	6/1999	Lauder et al.	D774,566	S	12/2016	Balan et al.	
D413,338	S	8/1999	Pueyo Molina	D774,567	S	12/2016	Balan et al.	
5,937,550	A	8/1999	Emrich	D775,240	S	12/2016	Balan et al.	
D414,193	S	9/1999	Lauder et al.	D775,241	S	12/2016	Balan et al.	
D415,173	S	10/1999	Zaun	D775,242	S	12/2016	Balan et al.	
5,983,534	A	11/1999	Robinson et al.	D775,243	S	12/2016	Serrurier et al.	
D417,877	S	12/1999	Lauder et al.	D775,673	S	1/2017	Balan et al.	
6,032,390	A	3/2000	Bierwith	D782,546	S	3/2017	Balan et al.	
D429,256	S	8/2000	Zaun	9,644,347	B2	5/2017	Balan et al.	
D429,258	S	8/2000	Zaun	9,644,348	B2	5/2017	Balan et al.	
6,321,471	B2	11/2001	Fernandez Muñoz et al.	D790,601	S	6/2017	Balan et al.	
D454,891	S	3/2002	Ketting et al.	D790,602	S	6/2017	Balan et al.	
H2020	H	5/2002	Kesavan et al.	D790,603	S	6/2017	Balan et al.	
D460,464	S	7/2002	Ketting et al.	D790,604	S	6/2017	Balan et al.	
D461,198	S	8/2002	Ketting et al.	D790,605	S	6/2017	Balan et al.	
D461,832	S	8/2002	Ketting et al.	D790,606	S	6/2017	Balan et al.	
6,477,796	B1	11/2002	Cornelius	D790,607	S	6/2017	Balan et al.	
6,735,890	B2	5/2004	Carpenter et al.	D801,397	S	10/2017	Balan et al.	
6,745,503	B1	6/2004	Moreno et al.	D803,274	S	11/2017	Serrurier et al.	
6,766,602	B2	7/2004	Cox et al.	D803,275	S	11/2017	Serrurier et al.	
D499,749	S	12/2004	Lauder et al.	D803,897	S	11/2017	Serrurier et al.	
6,836,983	B2	1/2005	Moreno et al.	D803,898	S	11/2017	Serrurier et al.	
6,865,828	B1	3/2005	Molino et al.	D803,899	S	11/2017	Serrurier et al.	
6,871,426	B2	3/2005	Keech et al.	D803,900	S	11/2017	Serrurier et al.	
D505,137	S	5/2005	Steinlage et al.	D803,901	S	11/2017	Serrurier et al.	
D512,078	S	11/2005	Poutre	D803,902	S	11/2017	Serrurier et al.	
D527,029	S	8/2006	Lauder et al.	D805,112	S	12/2017	Serrurier et al.	
7,100,315	B2	9/2006	Carpenter et al.	D805,562	S	12/2017	Serrurier et al.	
7,168,193	B2	1/2007	Moreno et al.	D806,139	S	12/2017	Serrurier et al.	
D552,632	S	10/2007	De Martiis	D806,140	S	12/2017	Serrurier et al.	
7,299,570	B2	11/2007	Emrich et al.	D806,141	S	12/2017	Serrurier et al.	
D560,232	S	1/2008	De Martiis	D806,142	S	12/2017	Serrurier et al.	
7,367,144	B2	5/2008	Jones et al.	D806,758	S	1/2018	Serrurier et al.	
D614,206	S	4/2010	Ruvang	D806,759	S	1/2018	Serrurier et al.	
7,739,814	B2	6/2010	Carpenter et al.	9,976,287	B2	5/2018	Kunz	
7,762,015	B2	7/2010	Smith et al.	D832,310	S	10/2018	Balan et al.	
D624,943	S	10/2010	Gibbon	10,119,252	B2	11/2018	Campomanes	
				D840,441	S	2/2019	Serrurier et al.	
				D842,345	S	*	3/2019	Kunz D15/29
				D842,347	S	*	3/2019	Bjerke D15/29
				2004/0010949	A1	1/2004	Laguarda et al.	

(56)

References Cited

U.S. PATENT DOCUMENTS

2005/0050775 A1 3/2005 Clendenning et al.
 2008/0028644 A1 2/2008 Almendros et al.
 2011/0000109 A1 1/2011 Woerman et al.
 2012/0131821 A1 5/2012 Brufau Guinovart et al.
 2012/0260540 A1 10/2012 Guimaraes et al.
 2012/0297649 A1 11/2012 Gomar
 2013/0086825 A1 4/2013 Renski et al.
 2013/0185964 A1 7/2013 Anisy et al.
 2013/0333254 A1 12/2013 Wallis et al.
 2014/0082976 A1 3/2014 Vicq et al.
 2014/0173948 A1 6/2014 Ok et al.
 2014/0259806 A1 9/2014 Rimmey
 2014/0259808 A1 9/2014 LaHood et al.
 2014/0352182 A1 12/2014 LaHood et al.
 2015/0167278 A1 6/2015 Rivera et al.
 2016/0083935 A1 3/2016 Edmonds
 2016/0160475 A1 6/2016 Kunz
 2017/0328036 A1 11/2017 Bilal et al.
 2017/0328038 A1 11/2017 Campomanes et al.

FOREIGN PATENT DOCUMENTS

CL 1193-1999 9/1999
 CL 223-1999 11/1999
 CL 1457-1999 11/1999
 CL 1583-1999 6/2000
 CL 2671-2005 7/2006
 CL 3115-2005 9/2006
 CL 3116-2005 9/2006
 CL 173-2008 8/2008
 CL 174-2008 8/2008
 CL 2524-2008 1/2009
 CL 1764-2008 7/2009
 CL 618-2010 11/2010
 CL 739-2010 12/2010
 CL 291-2012 11/2012
 CN 3462432 7/2005
 EM 000089099-0001-- 10/2003
 0003
 EM 000877477-0001-- 1/2008
 0009
 EM 000895396-0001-- 3/2008
 0015
 EP 0 411 486 A1 2/1991
 EP 1 174 547 B1 8/2006

EP 2 011 927 A2 1/2009
 GB 1049195 3/1988
 GB 1050103 4/1988
 GB 2010025 4/1990
 GB 2010026 4/1990
 GB 2057051 12/1995
 GB 2057052 12/1995
 GB 2057053 12/1995
 GB 2060104 4/1996
 GB 2060105 4/1996
 GB 2057055 5/1996
 GB 2091441 10/1999
 GB 2091502 10/1999
 GB 2095654 3/2000
 GB 2097590 3/2000
 GB 2097591 4/2000
 GB 2097592 4/2000
 GB 2097593 5/2000
 GB 2104929 3/2001
 GB 2106421 4/2001
 WO 2015/165505 11/2015

OTHER PUBLICATIONS

Caterpillar Inc., "Cat Backhoe Loader Options," published Jan. 1, 2005.
 Caterpillar Inc., Cat® Advansys™ Tips and Adapters, brochure (4 pages), 2017.
 U.S. Appl. No. 16/295,022, titled "Work Implement Assembly Using a Center Adapter Cover", filed Mar. 7, 2019. (Unpublished).
 U.S. Appl. No. 16/295,043, titled "Work Implement Assembly Using a Corner Adapter Cover", filed Mar. 7, 2019. (Unpublished).
 U.S. Appl. No. 16/295,139, titled "Work Implement Assembly Using an Adapter Mating With a Notched Base Edge", filed Mar. 7, 2019. (Unpublished).
 U.S. Appl. No. 16/295,180, titled "Work Implement Assembly Using a Load Sharing Block With an Arcuate Profile", filed Mar. 7, 2019. (Unpublished).
 U.S. Appl. No. 16/295,235, titled "Work Implement Assembly Using a Center Adapter Mating With a Notched Base Edge", filed Mar. 7, 2019. (Unpublished).
 U.S. Appl. No. 16/295,296, titled "Work Implement Assembly Using a Corner Adapter Mating With a Notched Base Edge", filed Mar. 7, 2019. (Unpublished).
 U.S. Appl. No. 29/682,763, titled "Adapter for A Ground Engaging Machine Implement", filed Mar. 7, 2019. (Unpublished).

* cited by examiner

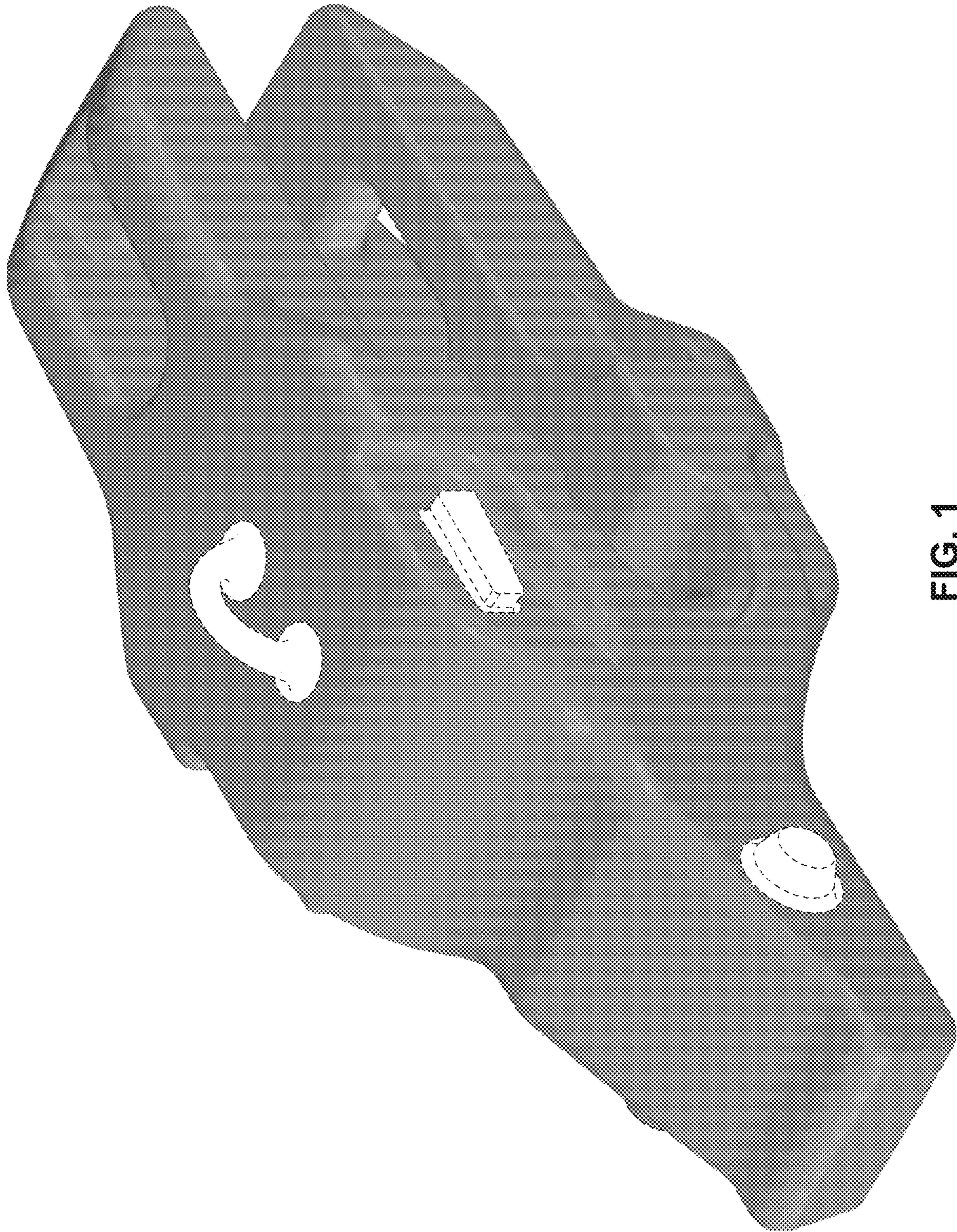

FIG. 1

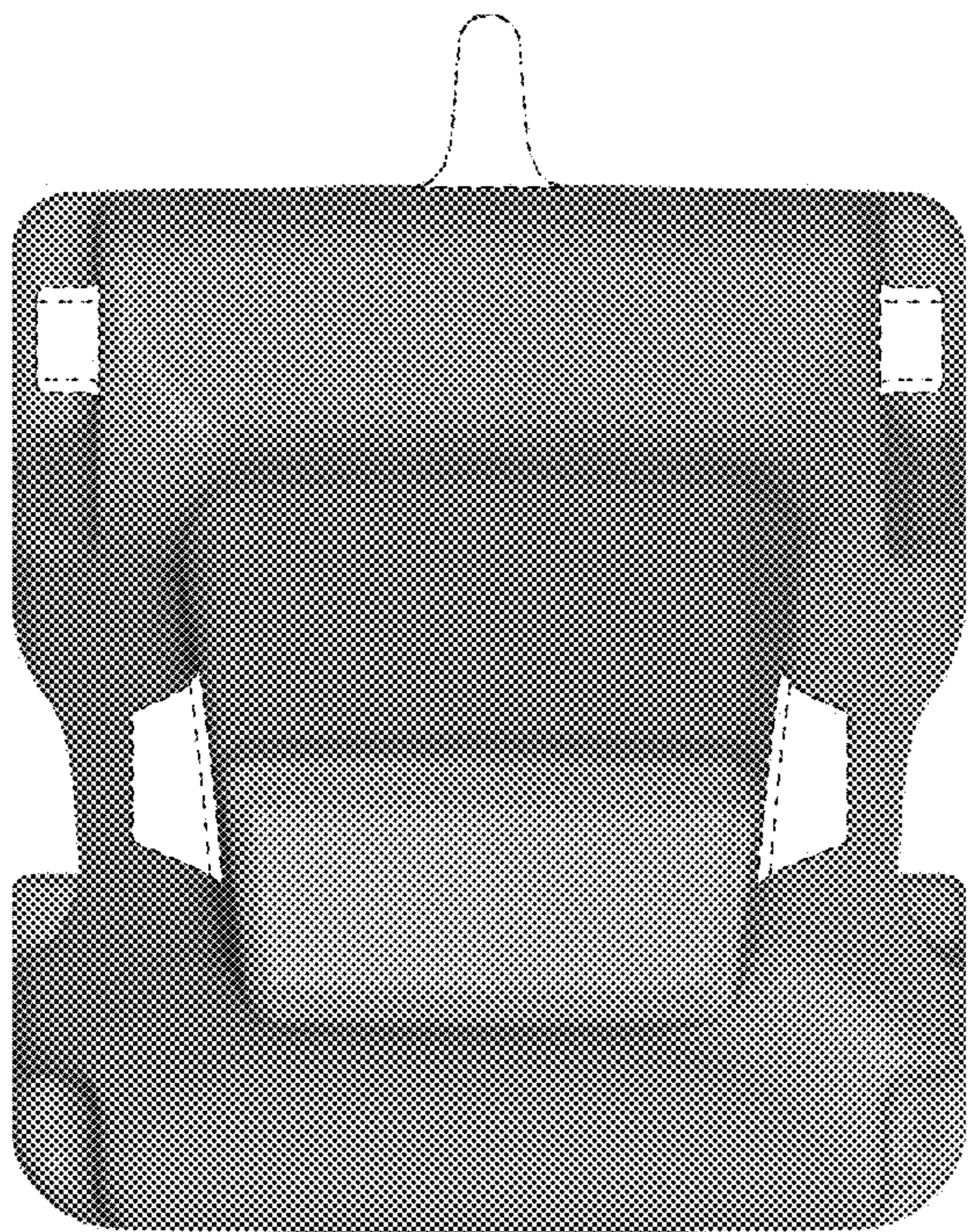

FIG. 2

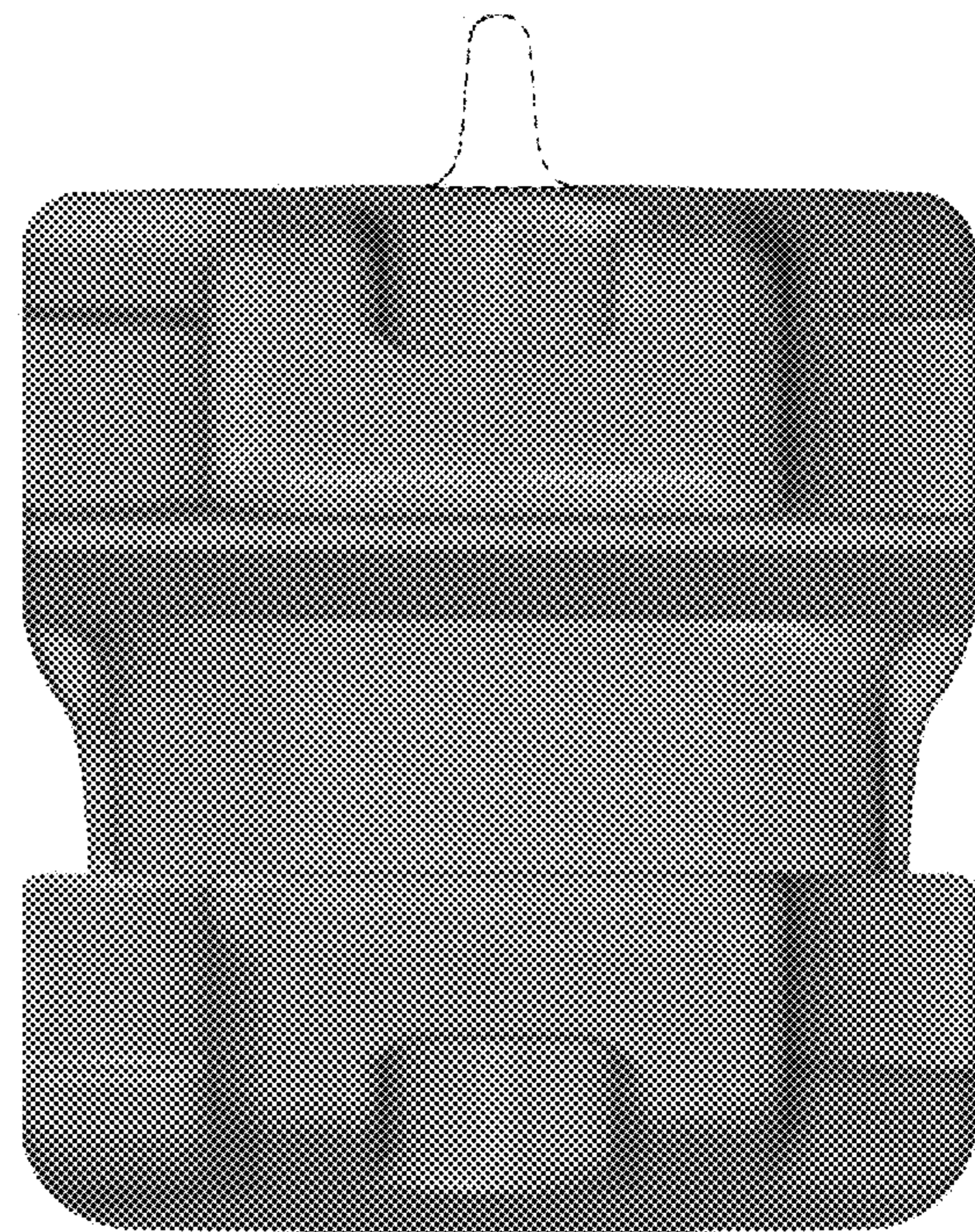

FIG. 3

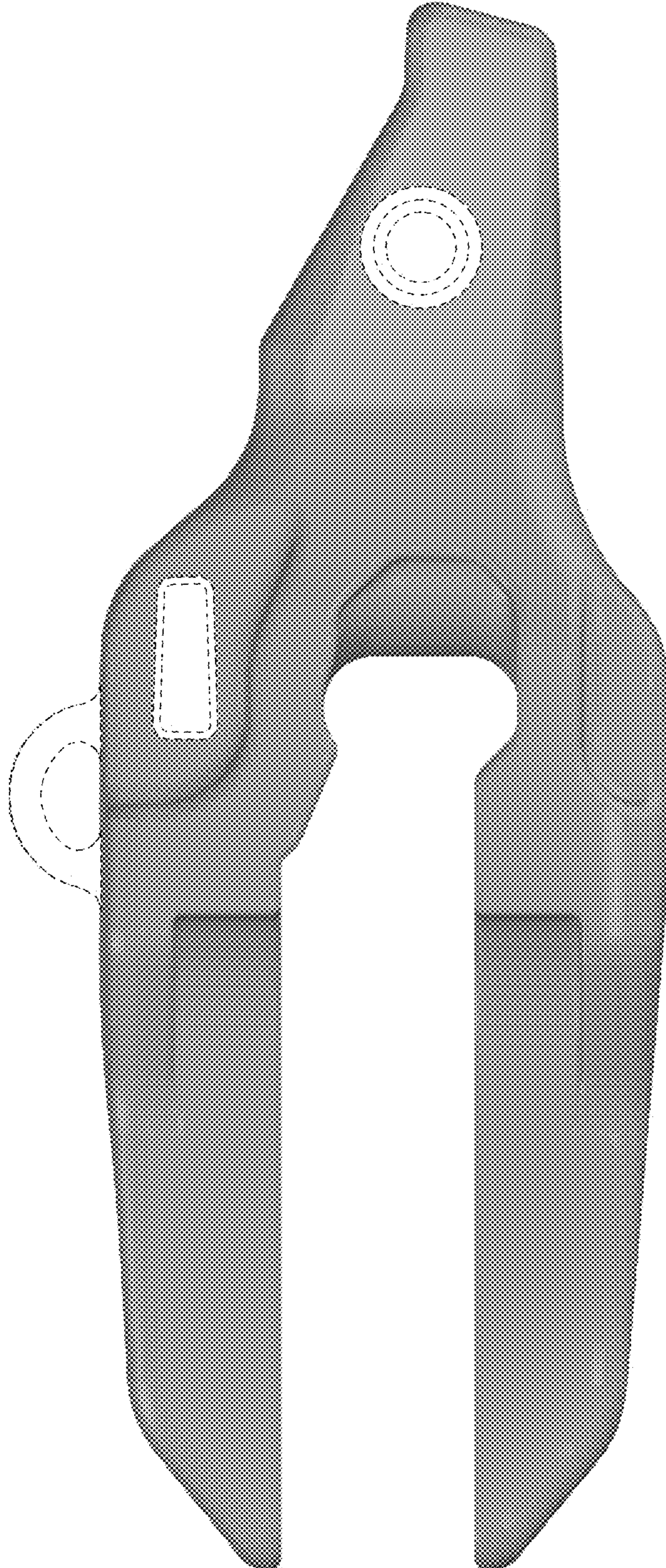

FIG. 4

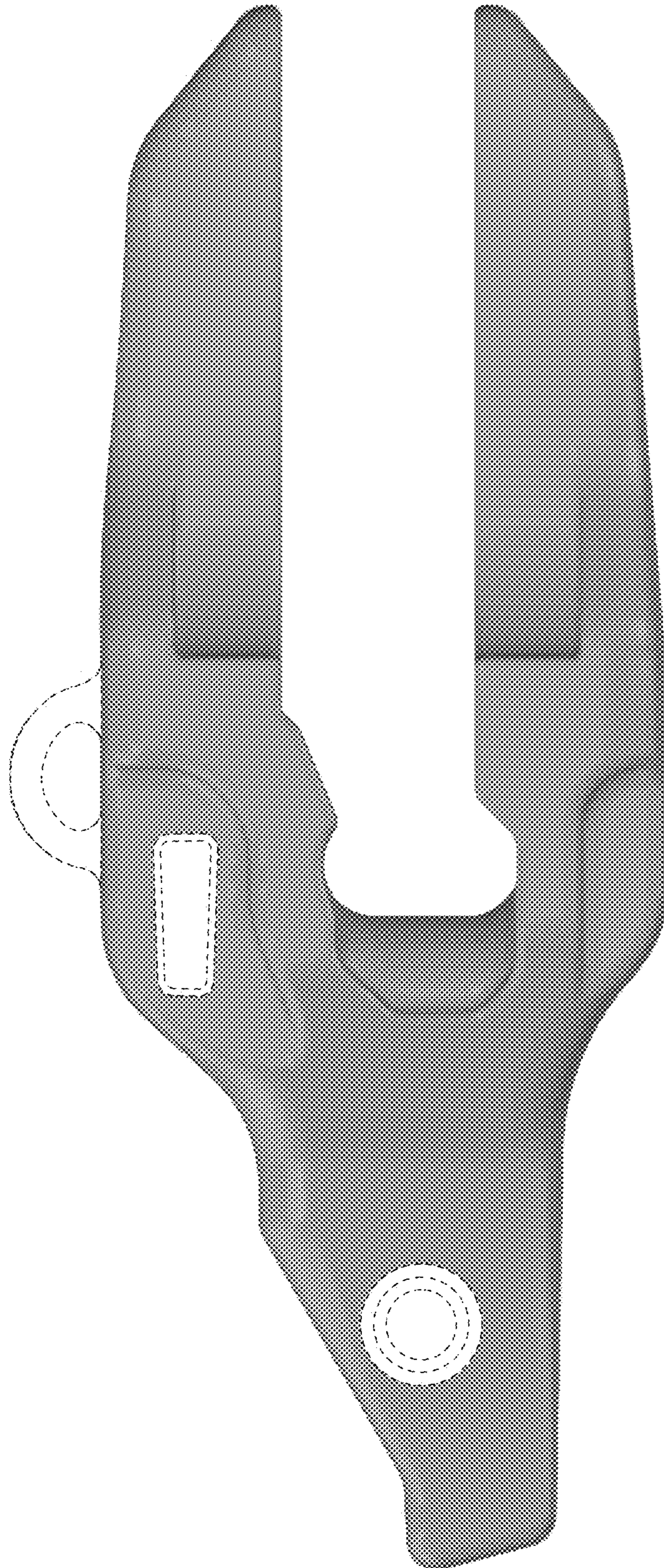

FIG. 5

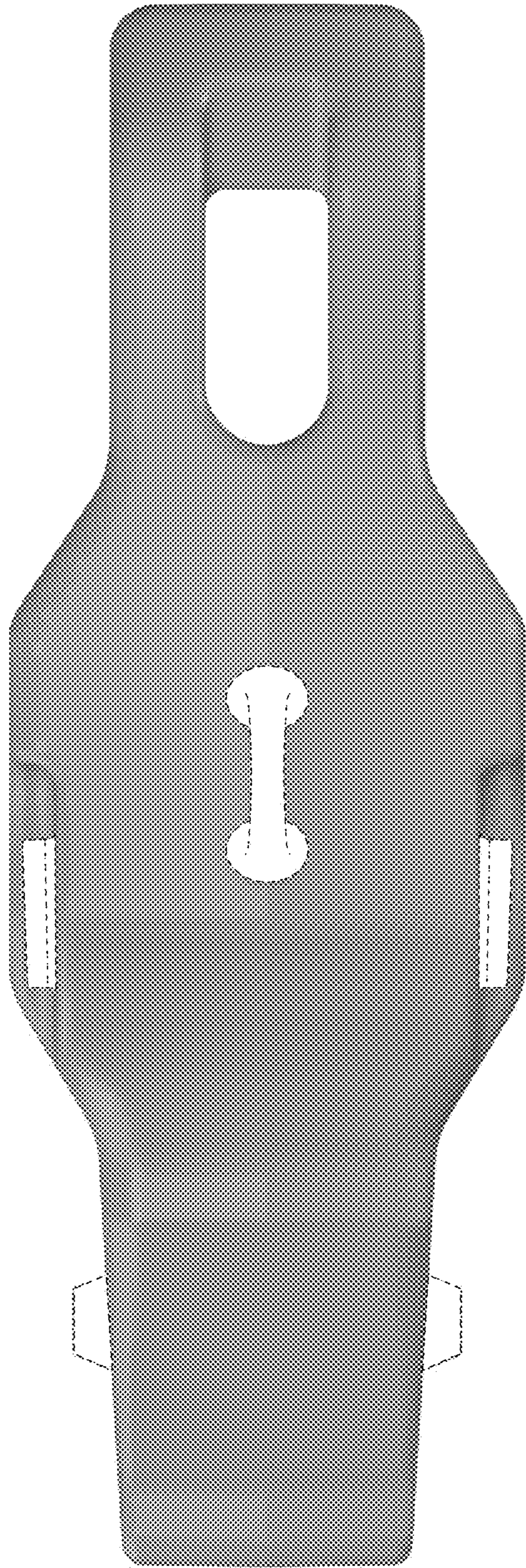

FIG. 6

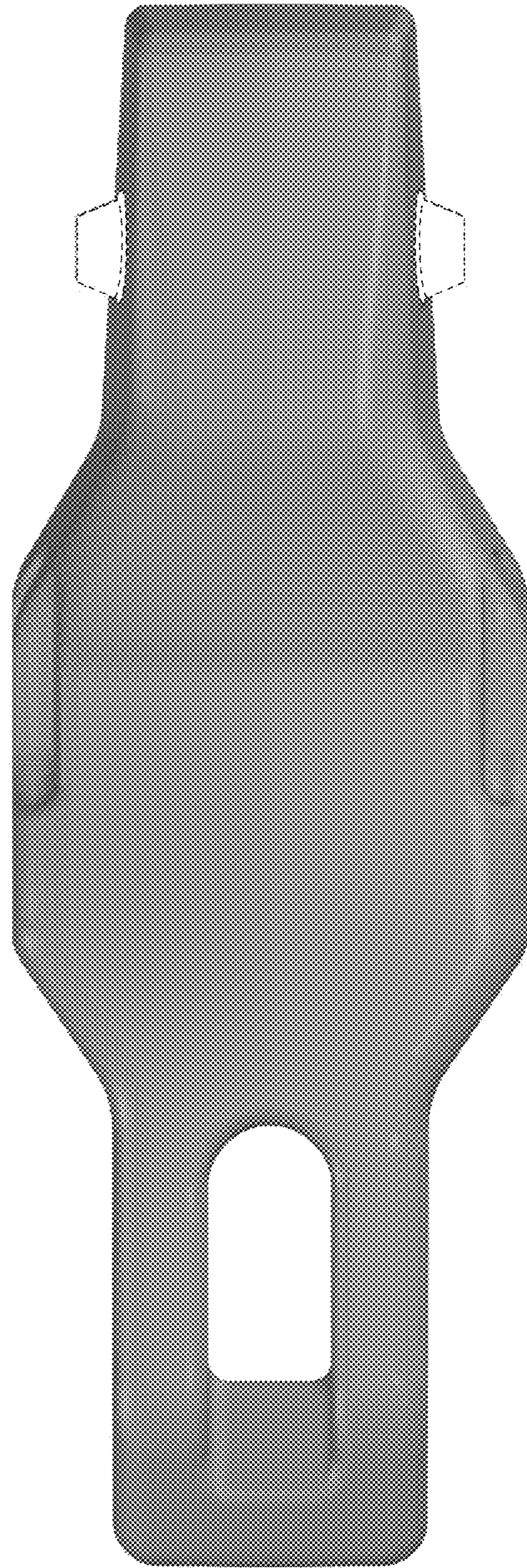

FIG. 7