



US00D888613S

(12) **United States Design Patent** (10) **Patent No.:** **US D888,613 S**  
**Muto et al.** (45) **Date of Patent:** **\*\* Jun. 30, 2020**

(54) **ELECTRIC VEHICLE**  
(71) Applicant: **Panasonic Intellectual Property Management Co., Ltd.**, Osaka-shi, Osaka (JP)  
(72) Inventors: **Kanji Muto**, Kanagawa (JP); **Naoki Usui**, Kanagawa (JP); **Tsuyoshi Nishio**, Chiba (JP)  
(73) Assignee: **Panasonic Intellectual Property Management Co., Ltd.**, Osaka (JP)  
(\*\*) Term: **15 Years**

D217,887 S \* 6/1970 Gerevitz ..... D12/40  
D234,418 S \* 3/1975 Forsey, Jr. et al. .... D12/40  
D235,750 S \* 7/1975 Edwards ..... D12/40  
D268,997 S \* 5/1983 Dubernard ..... D12/84  
D301,996 S \* 7/1989 Manning ..... D12/84  
D317,886 S \* 7/1991 Stannard ..... D12/40  
D320,581 S \* 10/1991 Gallitzendorfer ..... D12/37  
D389,417 S \* 1/1998 Polacek ..... D12/1  
D421,581 S \* 3/2000 Dimson ..... D12/37  
D563,831 S \* 3/2008 Suge et al.  
D617,236 S \* 6/2010 Counts ..... D12/84  
D733,001 S 6/2015 Itou et al.  
D777,604 S 1/2017 McNerney  
D784,853 S \* 4/2017 Gecchelin ..... D12/1  
D789,249 S \* 6/2017 Iparraguirre ..... D12/84

(Continued)

(21) Appl. No.: **29/688,569**  
(22) Filed: **Apr. 23, 2019**  
(30) **Foreign Application Priority Data**  
Oct. 26, 2018 (JP) ..... 2018-023489  
(51) **LOC (12) Cl.** ..... **12-14**  
(52) **U.S. Cl.**  
USPC ..... **D12/1**  
(58) **Field of Classification Search**  
USPC ... D12/1, 36, 37, 38, 39, 40, 41, 42, 43, 44,  
D12/46, 52, 85, 86, 93, 2, 3, 4, 5, 12, 14,  
D12/16.1; D15/199  
CPC .. B61B 12/002; B60F 1/00; B60F 1/02; B60F  
1/043; B60F 1/046; B62D 63/06  
See application file for complete search history.

Primary Examiner — Ania Aman  
(74) Attorney, Agent, or Firm — Brinks Gilson & Lione

(57) **CLAIM**

We claim the ornamental design for an electric vehicle, as shown and described.

**DESCRIPTION**

FIG. 1 is a front perspective view showing an electric vehicle of the present invention;  
FIG. 2 is a rear perspective view thereof;  
FIG. 3 is a front view thereof;  
FIG. 4 is a rear view thereof;  
FIG. 5 is a right side view thereof;  
FIG. 6 is a left side view thereof;  
FIG. 7 is a top view thereof;  
FIG. 8 is a bottom view thereof;  
FIG. 9 is a front perspective view thereof showing doors being opened; and,  
FIG. 10 is a front perspective view thereof showing an upper part of a body being separated from a lower part of the body. The broken lines show parts of the electric vehicle that represent unclaimed subject matter and form no part of the claimed design.

(56) **References Cited**  
U.S. PATENT DOCUMENTS  
1,861,001 A \* 5/1932 Fageol ..... B62D 31/02  
180/54.1  
D103,810 S \* 3/1937 Dittmar ..... D12/84  
D152,334 S \* 1/1949 Hanson et al. .... D12/103  
D196,906 S \* 11/1963 Dardenne ..... D12/102

**1 Claim, 10 Drawing Sheets**

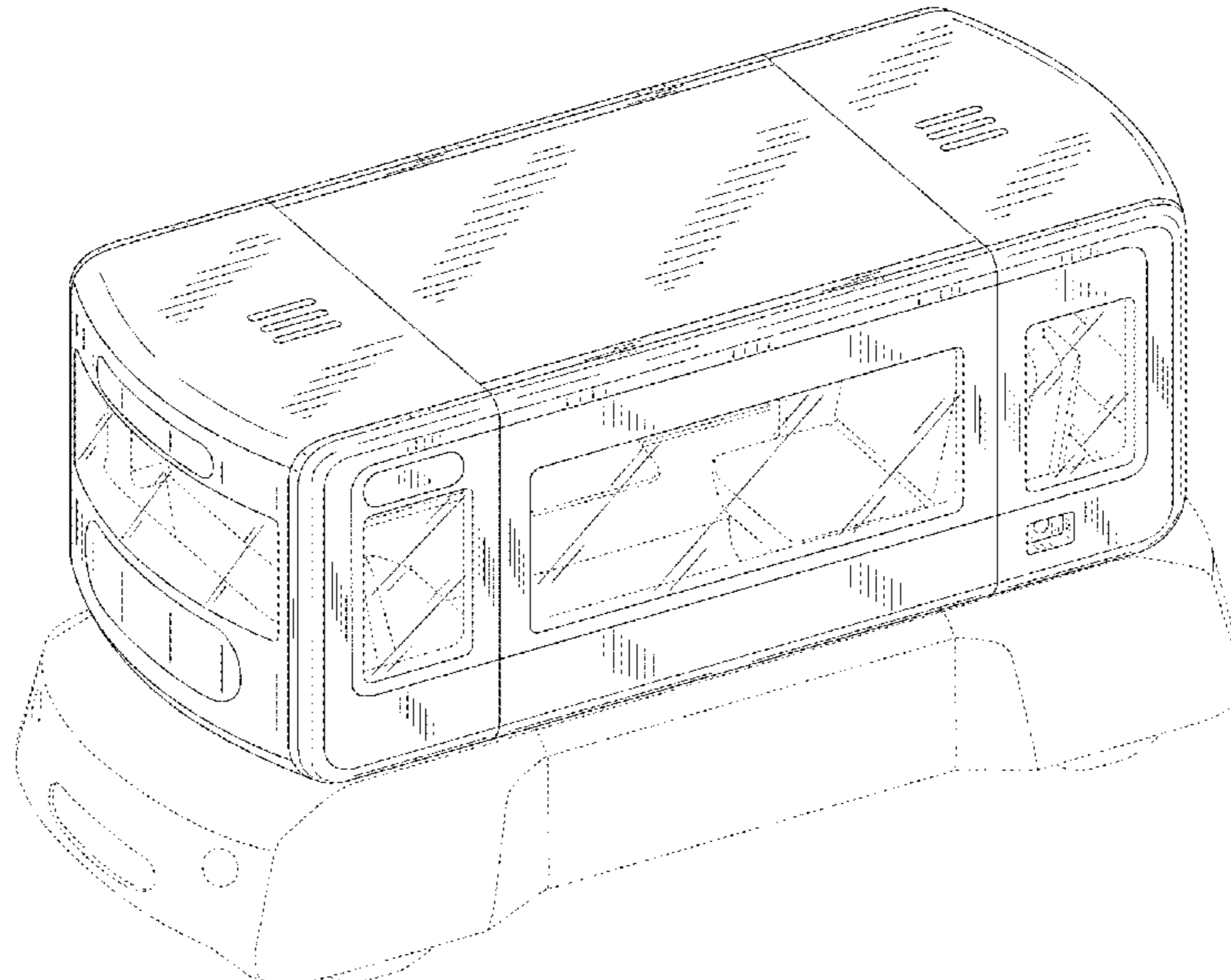

(56)

**References Cited**

U.S. PATENT DOCUMENTS

D800,017 S *	10/2017	Sapet .....	D12/86
D811,936 S	3/2018	Bod	
D829,605 S	10/2018	Sato et al.	
D832,742 S	11/2018	Fisker	
D845,832 S *	4/2019	Ishikawa .....	D12/1
D856,192 S *	8/2019	Yamada .....	D12/86
D874,339 S *	2/2020	Micek .....	D12/84
2015/0015017 A1 *	1/2015	Benoliel .....	B61B 15/00 296/26.02

\* cited by examiner

FIG. 1

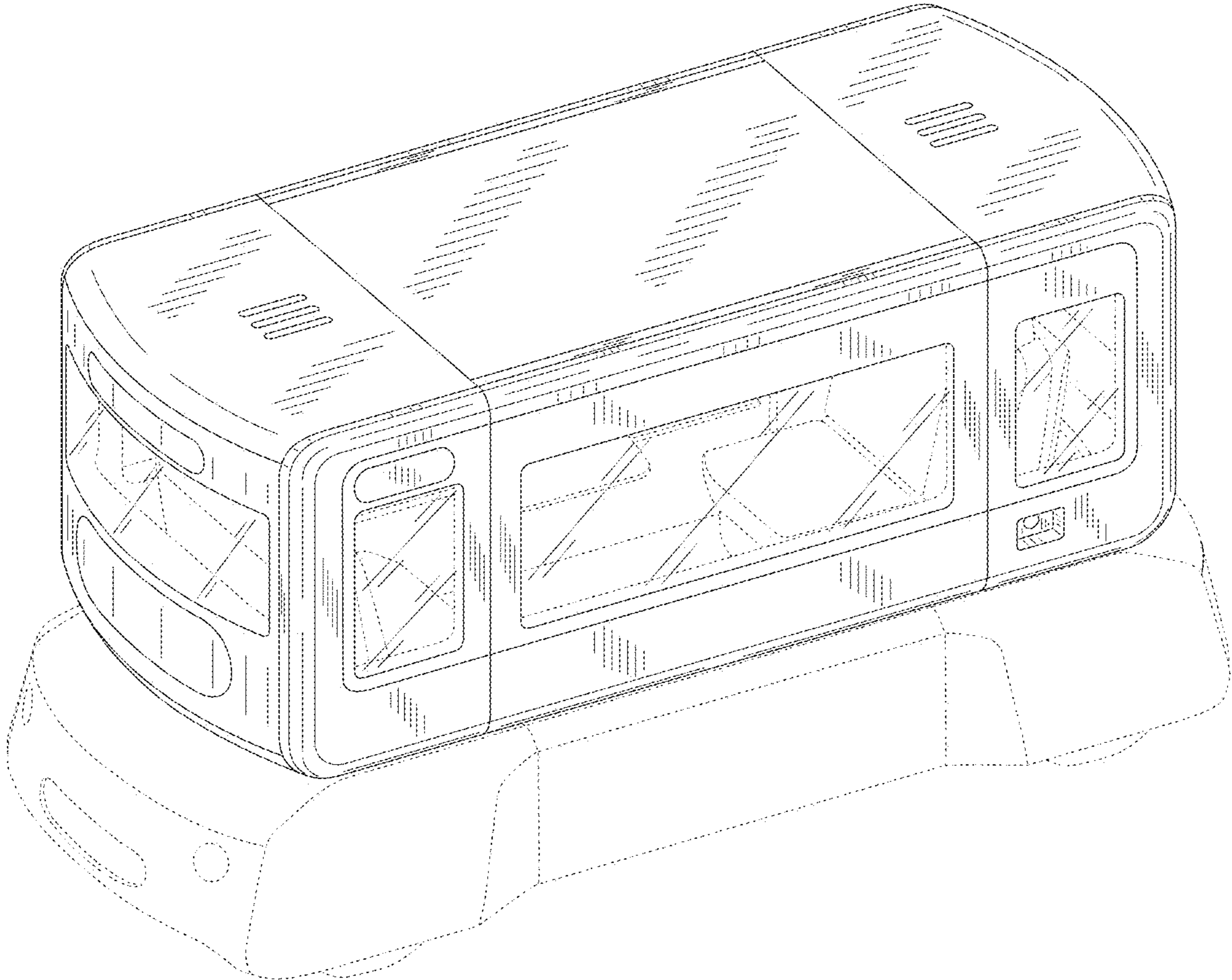

FIG. 2

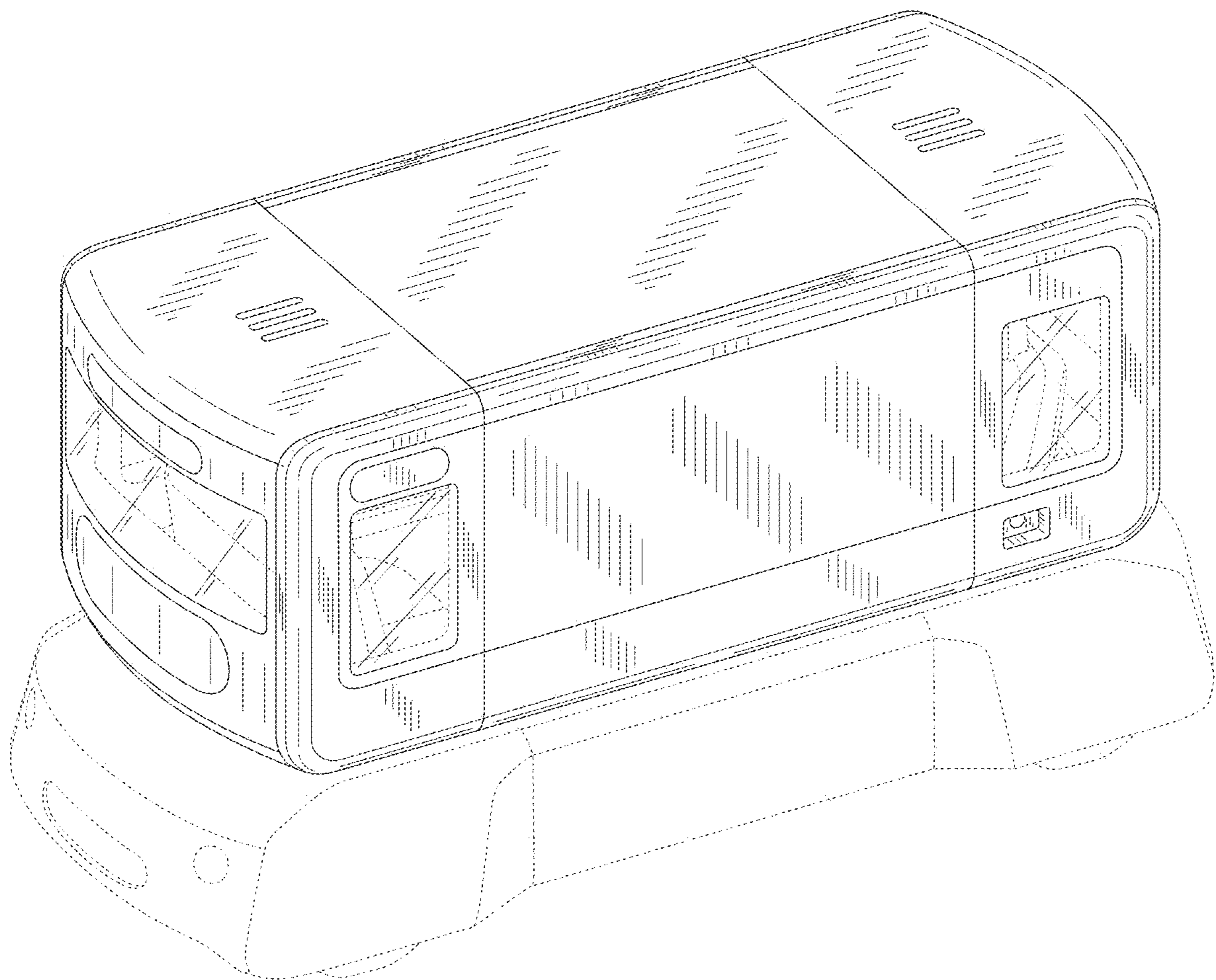

FIG. 3

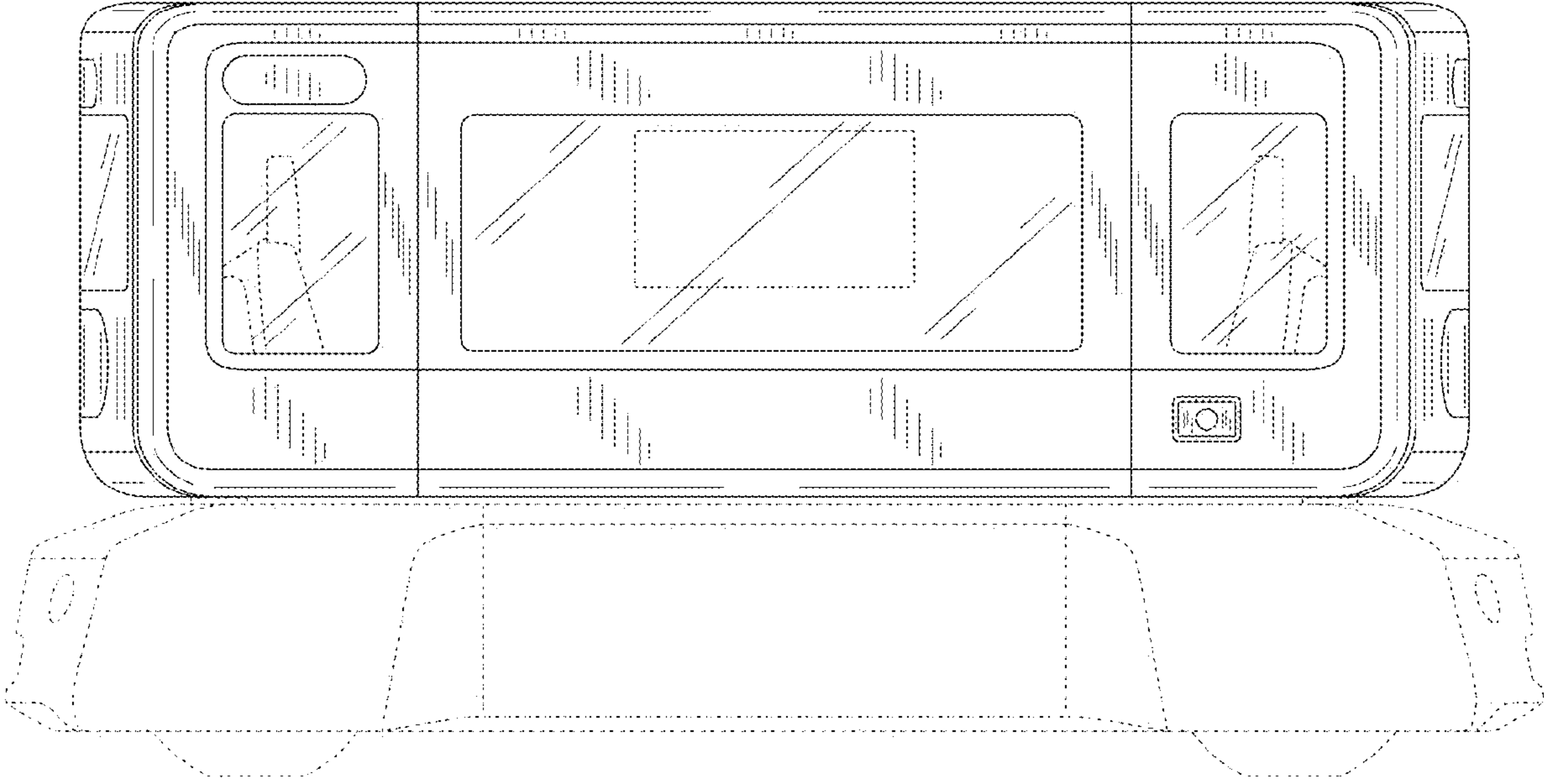

FIG. 4

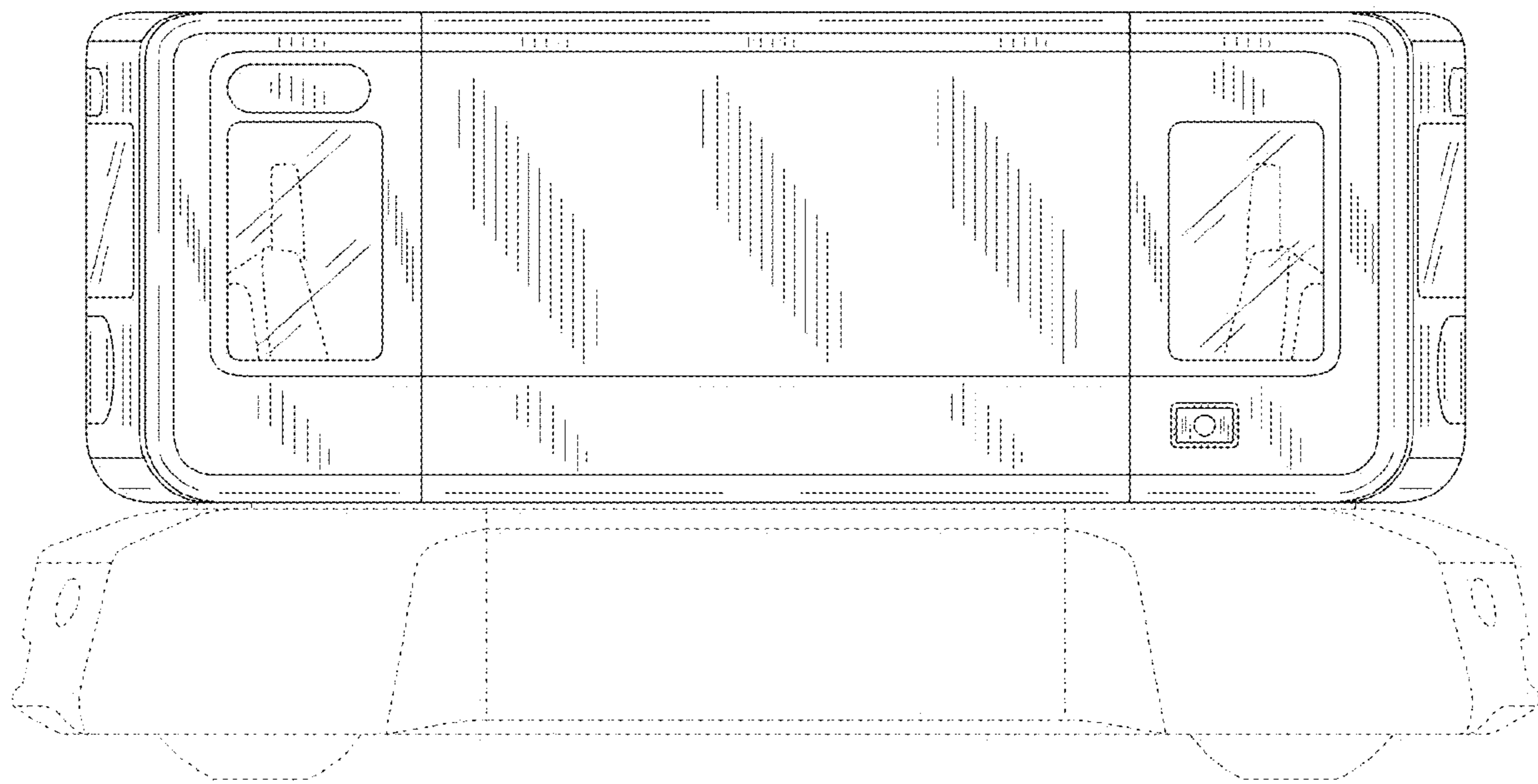

FIG. 5

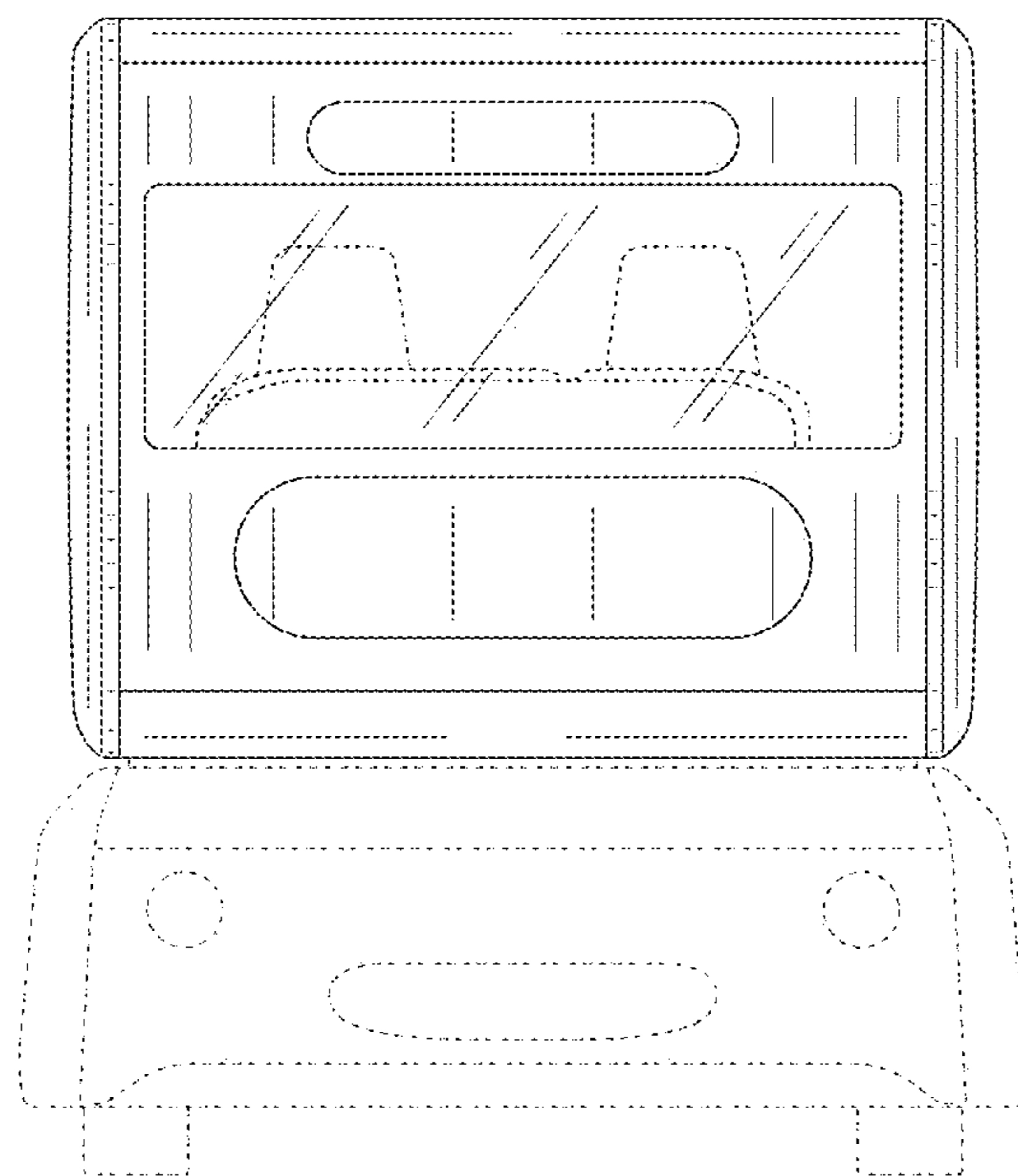

FIG. 6

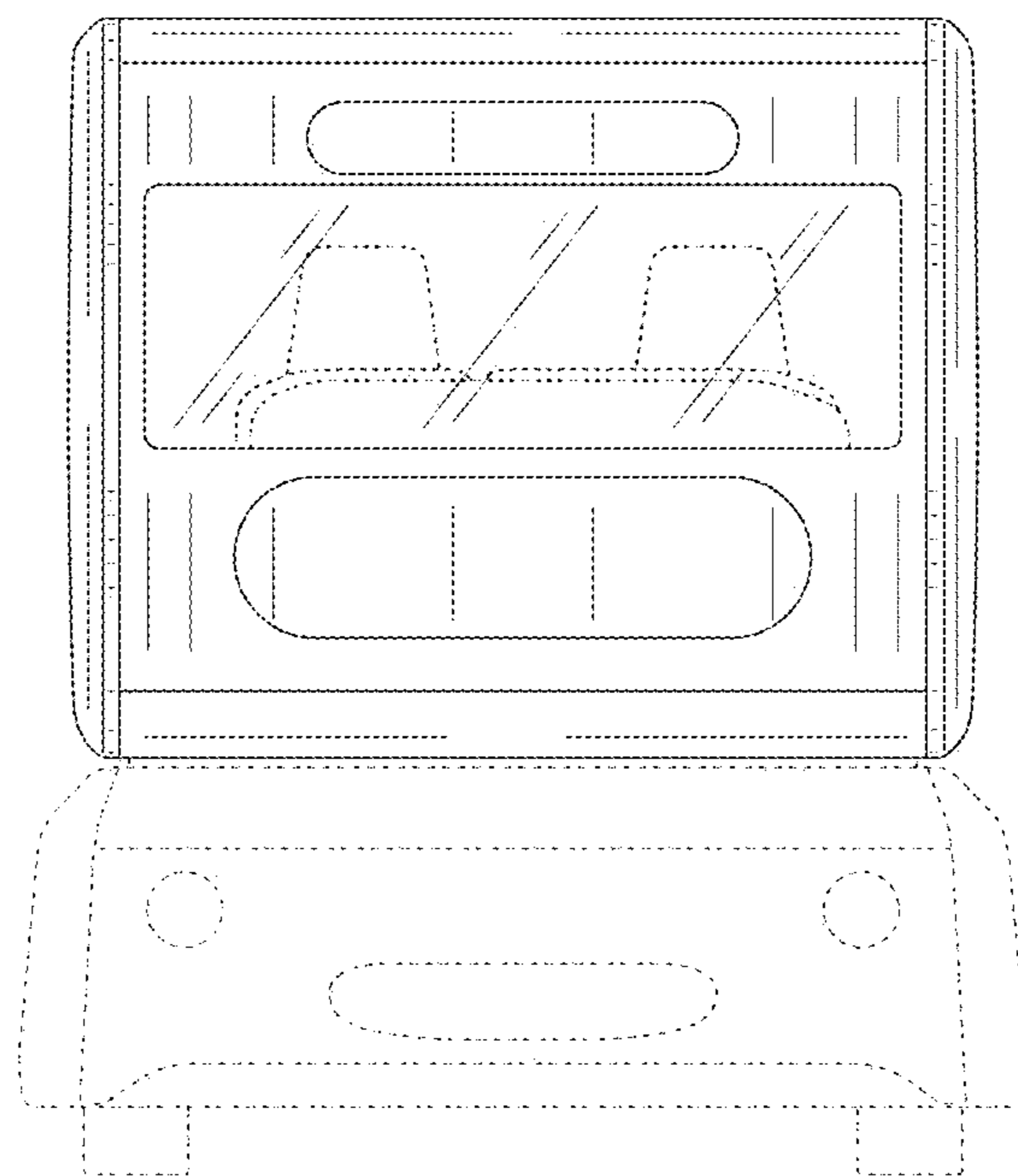



FIG. 7

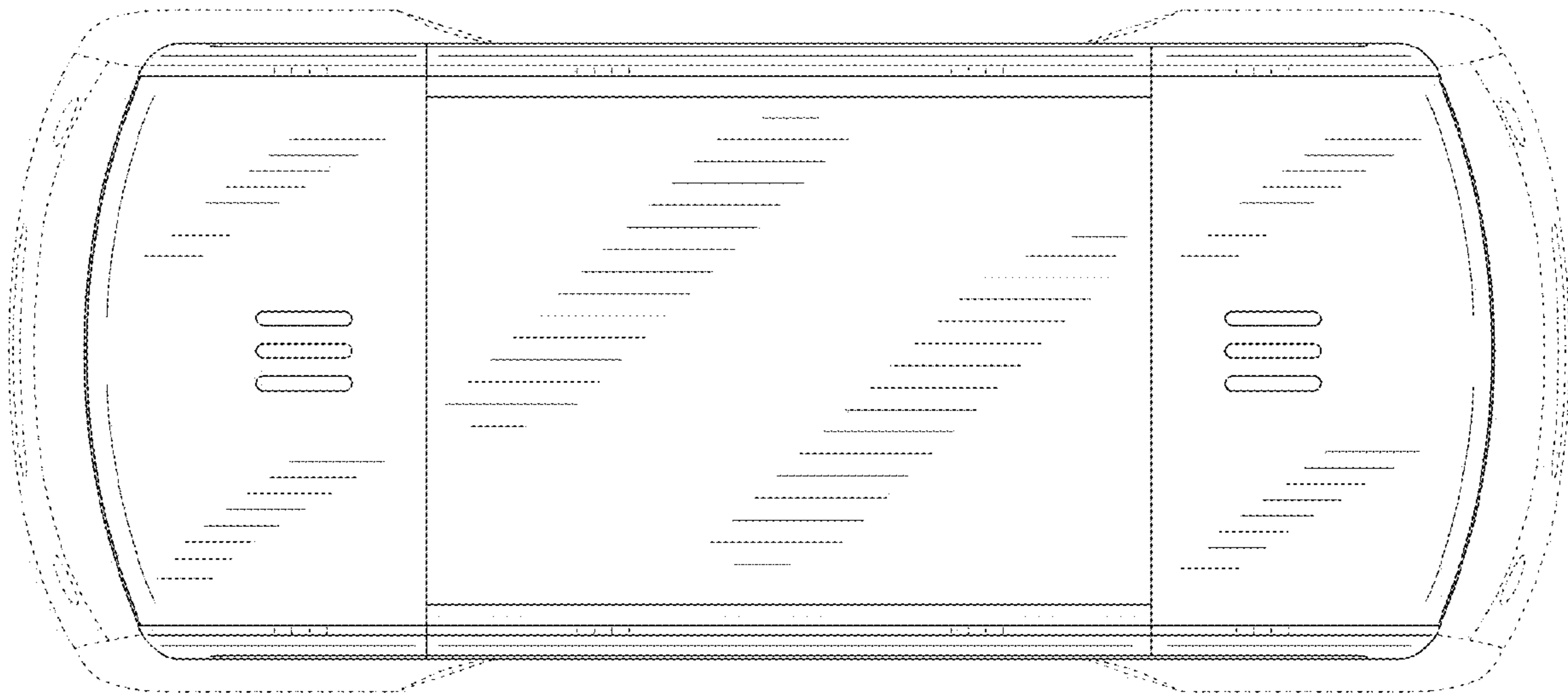

FIG. 8

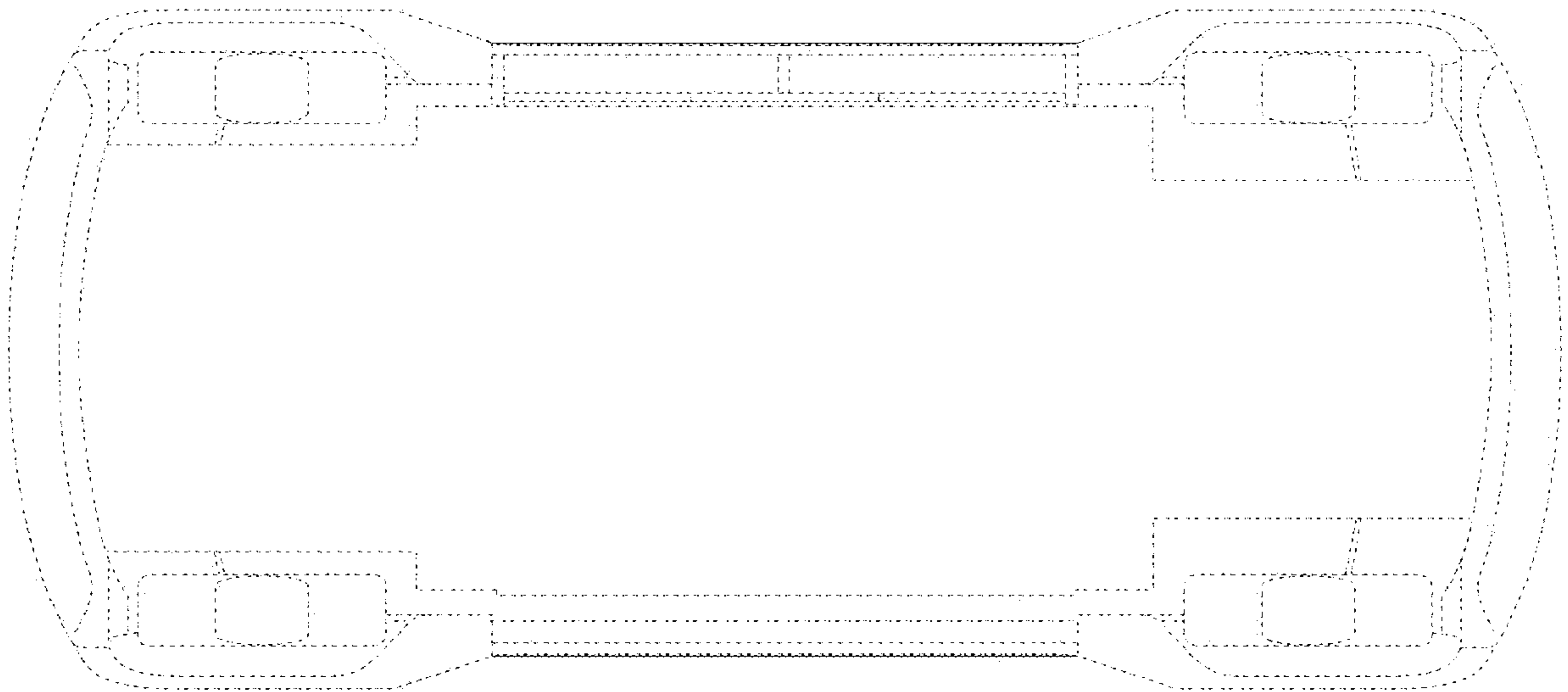

FIG. 9

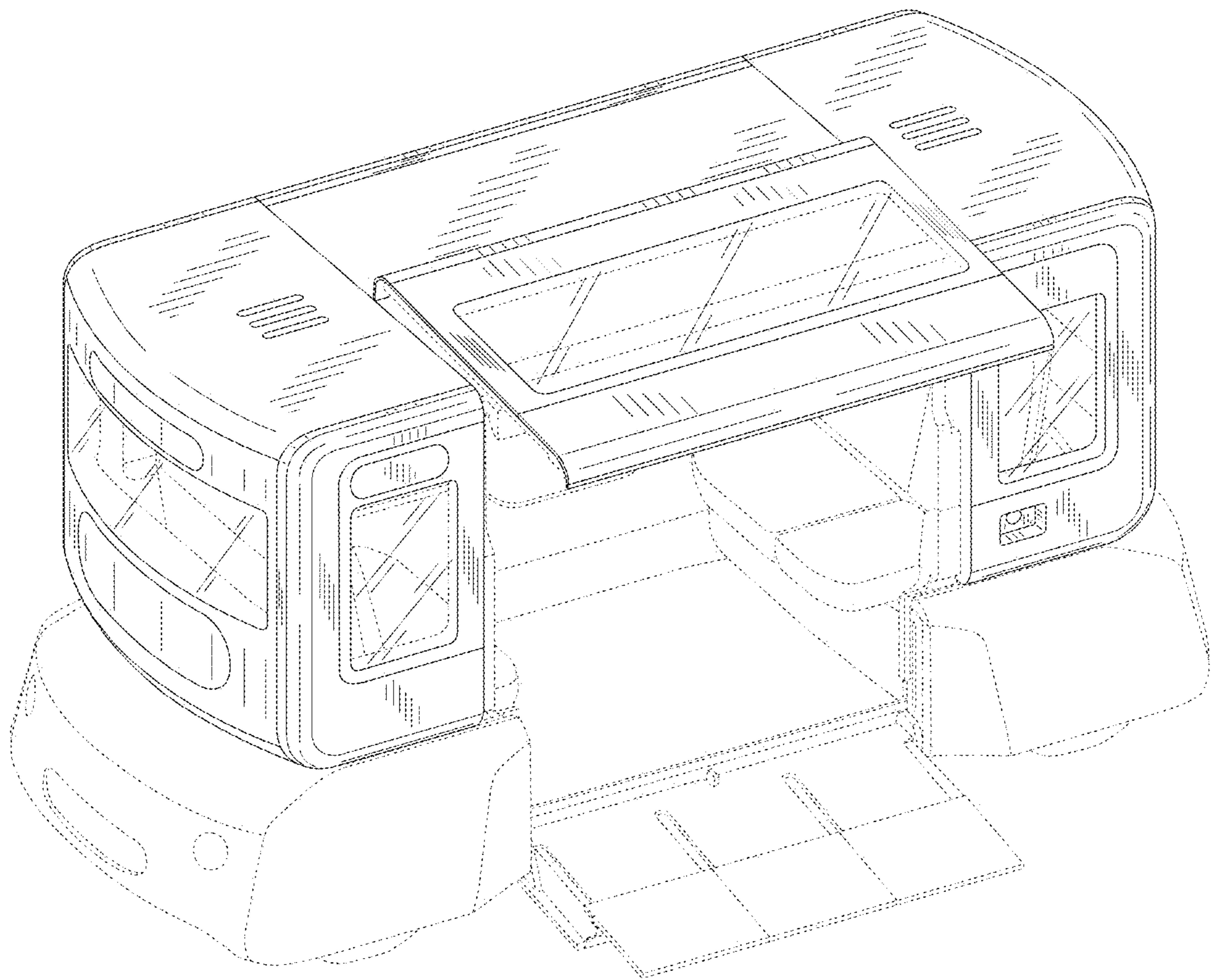

FIG. 10

