



US00D888521S

(12) **United States Design Patent** (10) **Patent No.:** **US D888,521 S**
Howseman, Jr. (45) **Date of Patent:** **** Jun. 30, 2020**

(54) **SPRAY GUN ELEVATOR**
(71) Applicant: **William E. Howseman, Jr.**, Camarillo, CA (US)
(72) Inventor: **William E. Howseman, Jr.**, Camarillo, CA (US)
(**) Term: **15 Years**
(21) Appl. No.: **29/653,910**
(22) Filed: **Jun. 19, 2018**
(51) **LOC (12) Cl.** **08-05**
(52) **U.S. Cl.**
USPC **D8/71; D15/199**
(58) **Field of Classification Search**
USPC **D8/71, 355, 354, 349, 51; D15/199**
CPC . **B05C 12/04; B05C 13/0431; B05C 13/0452; B05C 13/0292**
See application file for complete search history.

D621,857 S * 8/2010 Baratta D15/132
D629,026 S * 12/2010 Baratta D15/132
D655,593 S * 3/2012 Wagner, III D8/71
8,245,997 B2 * 8/2012 Baratta B25H 1/0064
248/176.3
8,453,597 B2 * 6/2013 Ansorge B05B 13/0452
118/309
8,627,780 B2 * 1/2014 Herre B05B 13/0431
118/323
9,630,199 B2 * 4/2017 Herre B05B 13/0431
2006/0275552 A1 * 12/2006 Vendlinski B05B 13/04
427/421.1
2008/0020135 A1 * 1/2008 Fouvet B05B 13/0292
427/181
2018/0093289 A1 * 4/2018 Raman G05D 1/0234

* cited by examiner

Primary Examiner — Philip S Hyder
(74) *Attorney, Agent, or Firm* — Law Offices of Steven W. Weinrieb

(57) **CLAIM**

The ornamental design for a spray gun elevator, as shown and described.

DESCRIPTION

FIG. 1 is a front, right side, top perspective view of the spray gun elevator showing my new design;
FIG. 2 is a front elevational view thereof;
FIG. 3 is a rear elevational view thereof;
FIG. 4 is a right side elevational view thereof;
FIG. 5 is a left side elevational view thereof;
FIG. 6 is a top plan view thereof; and,
FIG. 7 is a bottom plan view thereof.
The broken lines depict portions of the spray gun elevator that are not considered part of the claimed design.

1 Claim, 7 Drawing Sheets

(56) **References Cited**
U.S. PATENT DOCUMENTS

D273,300 S * 4/1984 Molaug D15/122
4,721,630 A * 1/1988 Takeo B05B 13/0292
118/314
5,266,115 A * 11/1993 Taccon B05B 13/0431
118/663
5,427,619 A * 6/1995 Ehinger B05B 13/0452
118/315
D414,669 S * 10/1999 Howard D15/140
D440,477 S * 4/2001 Pappas D8/71
6,692,201 B2 * 2/2004 Soderman B25H 1/0064
408/111
7,650,852 B2 * 1/2010 Clifford B05B 13/0431
118/305

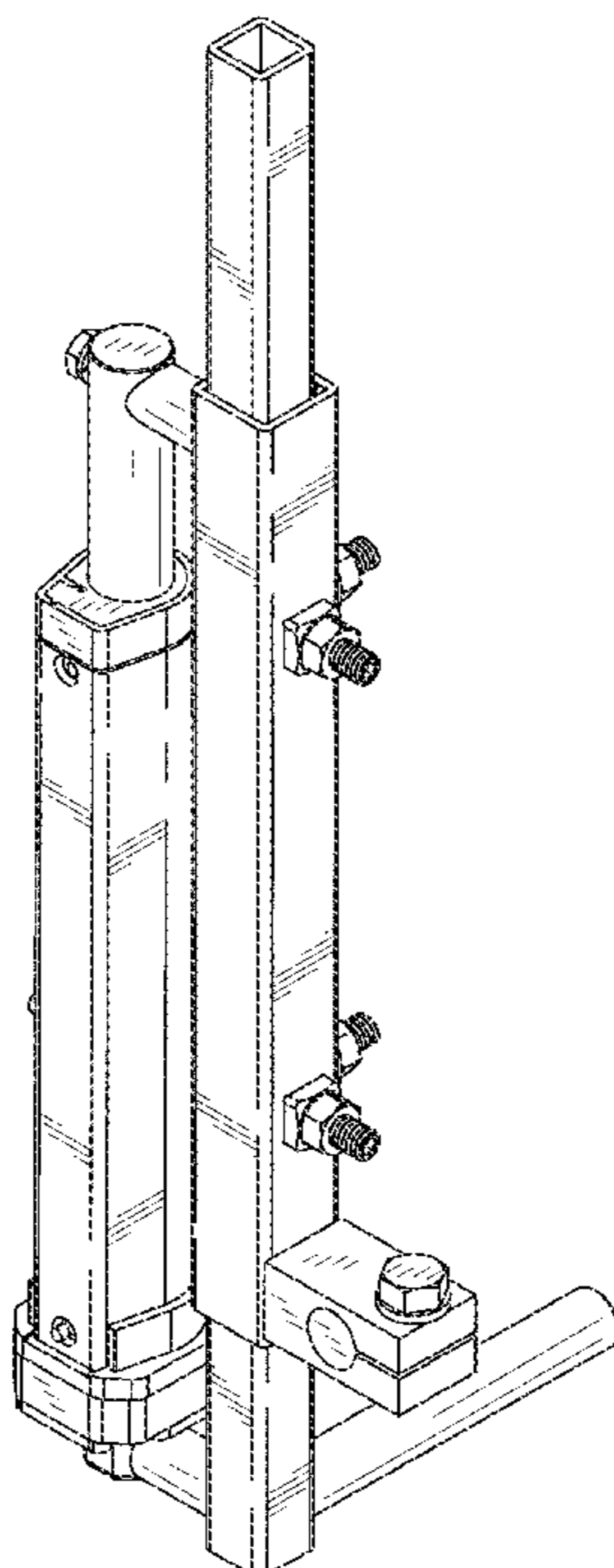

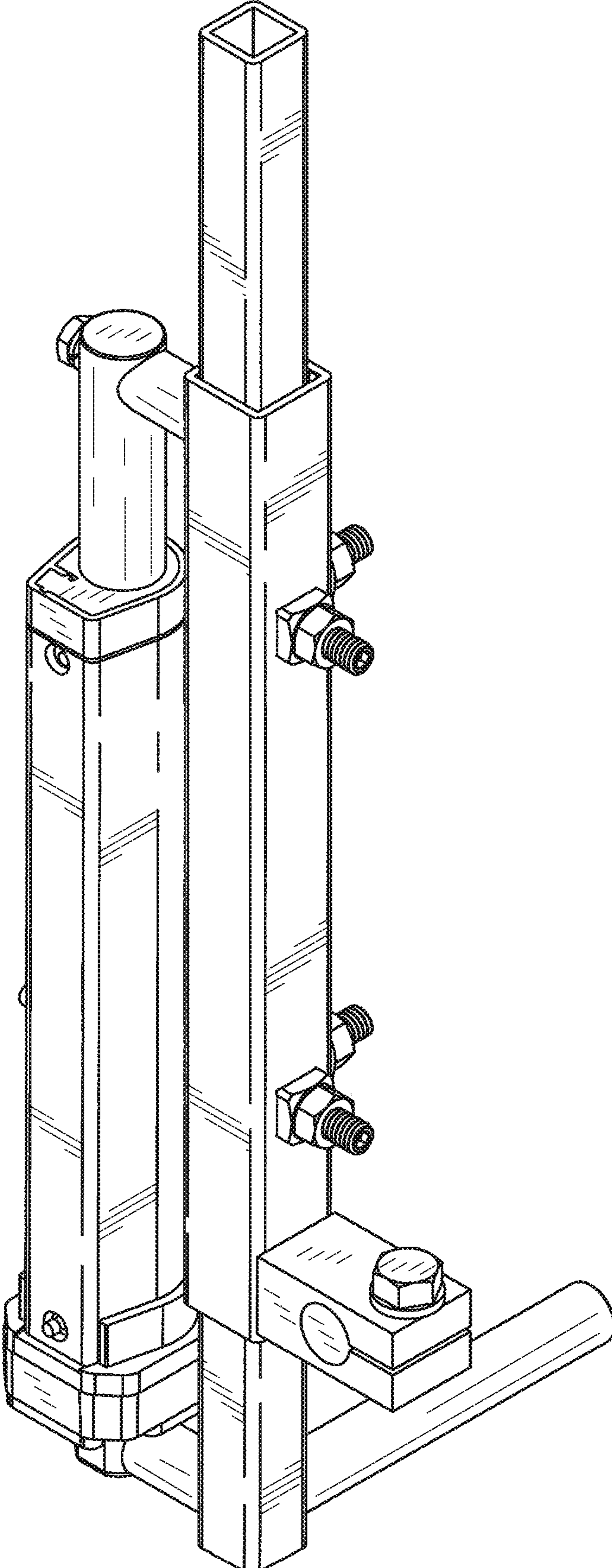

FIG. 1

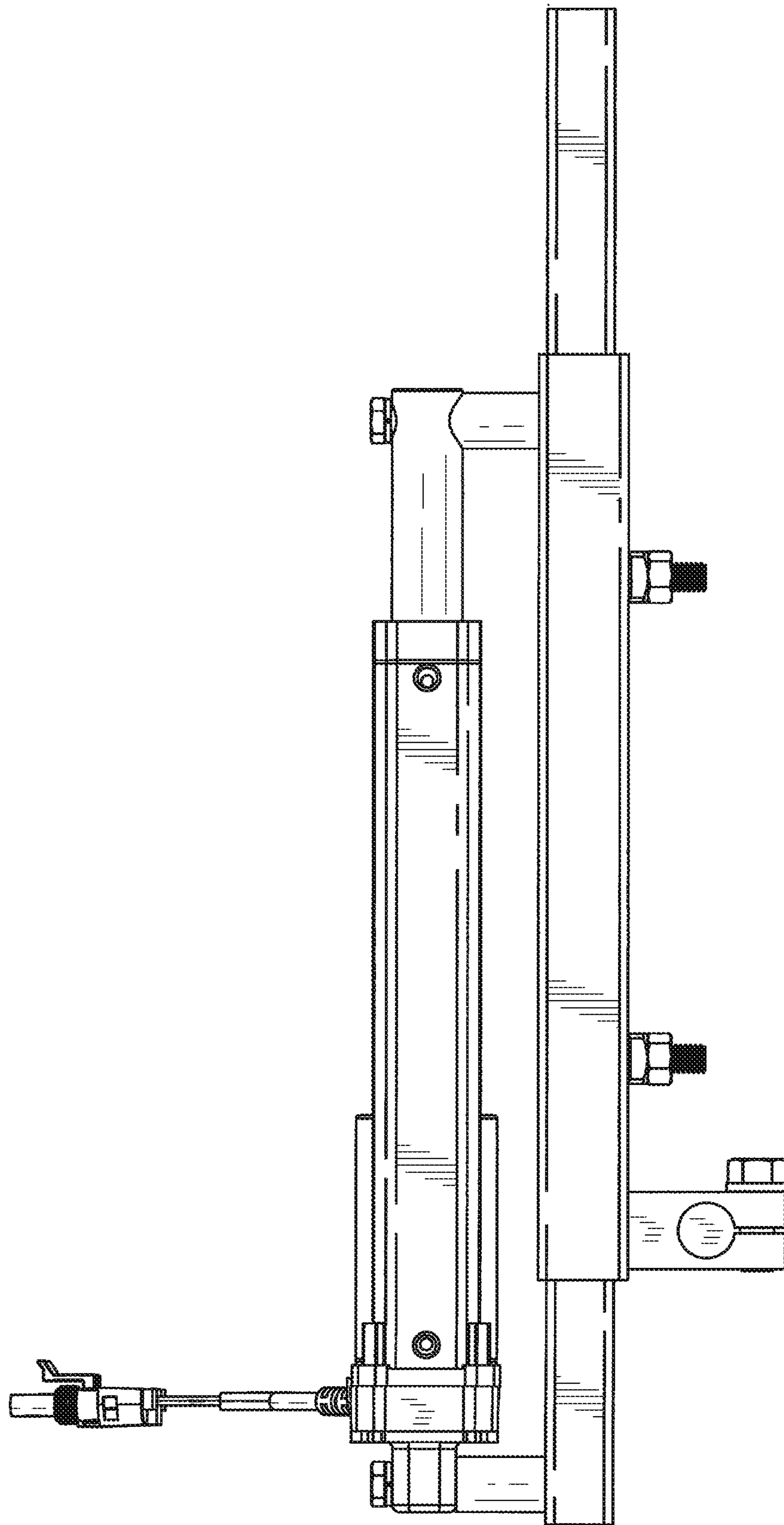

FIG. 2

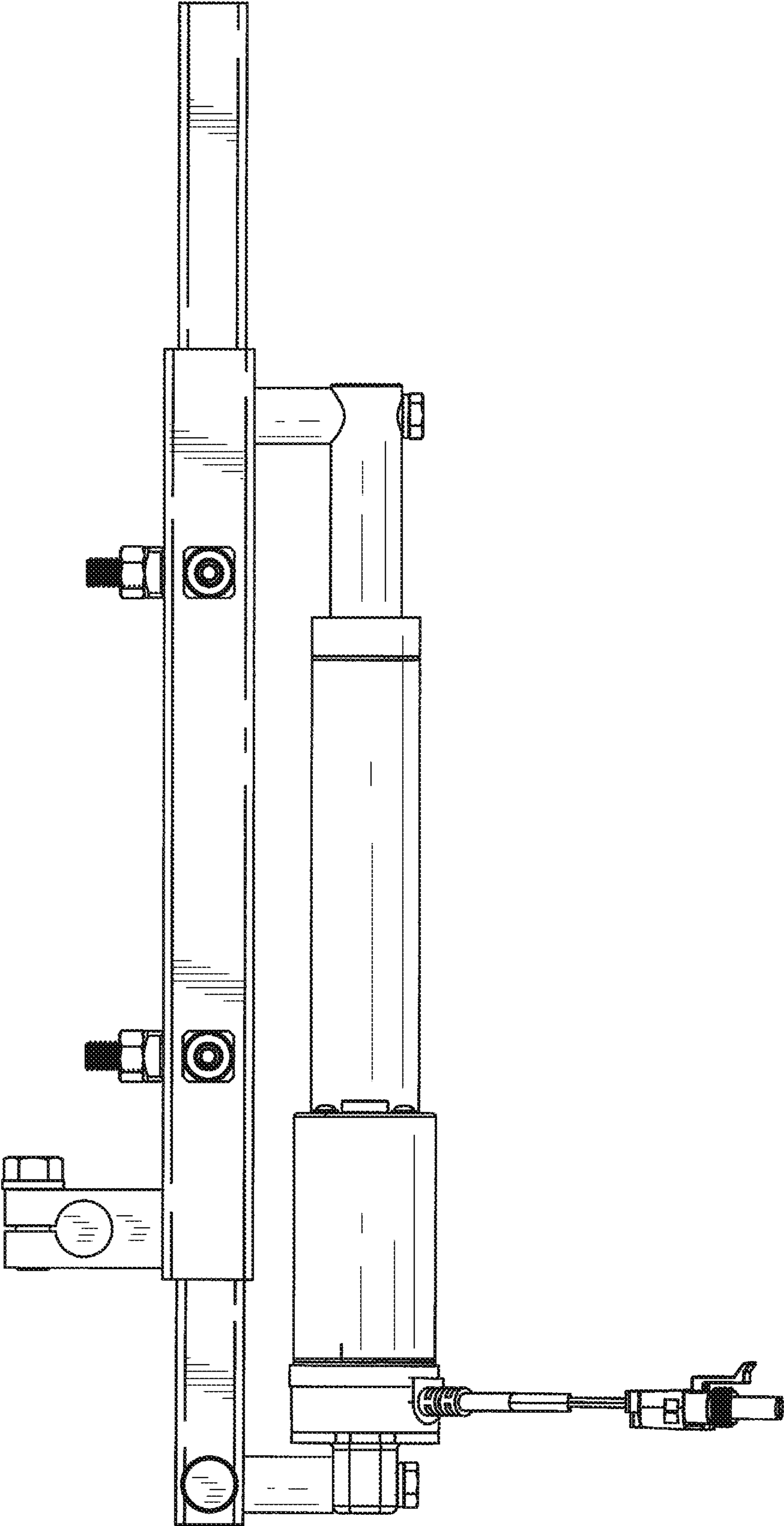

FIG. 3

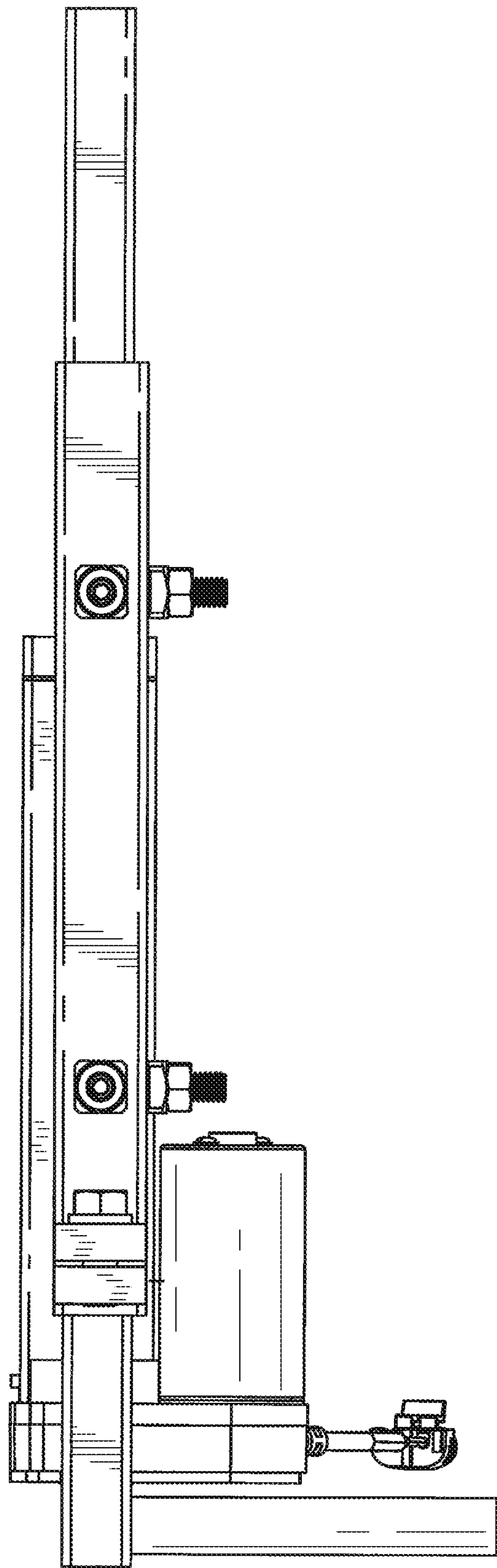

FIG. 4

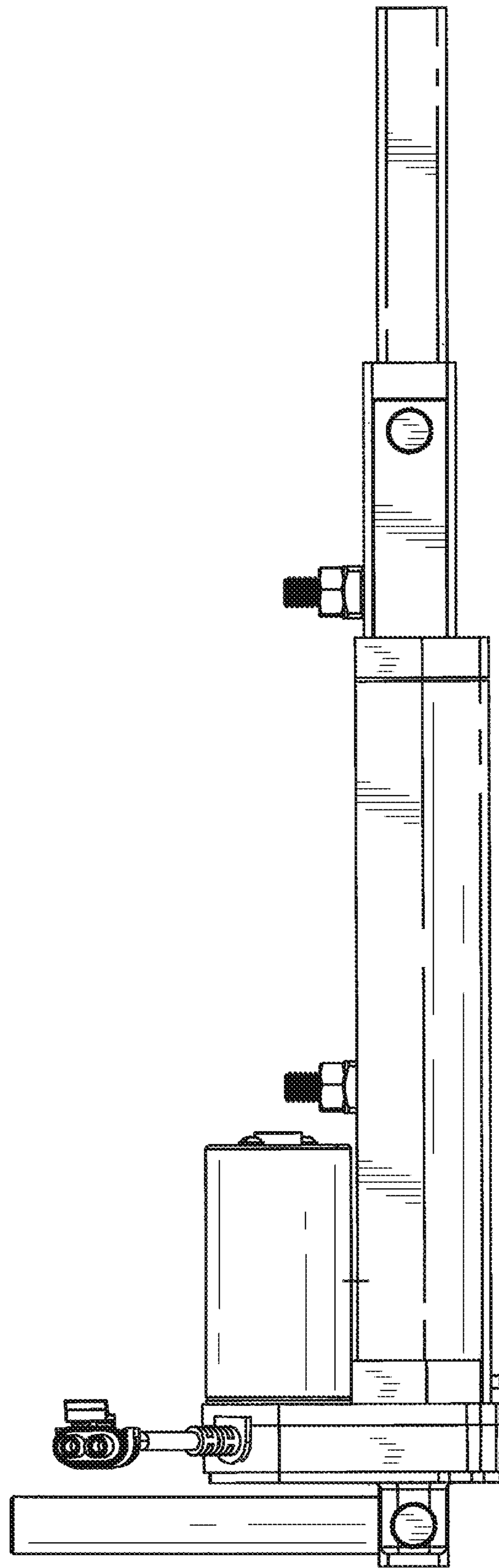

FIG. 5

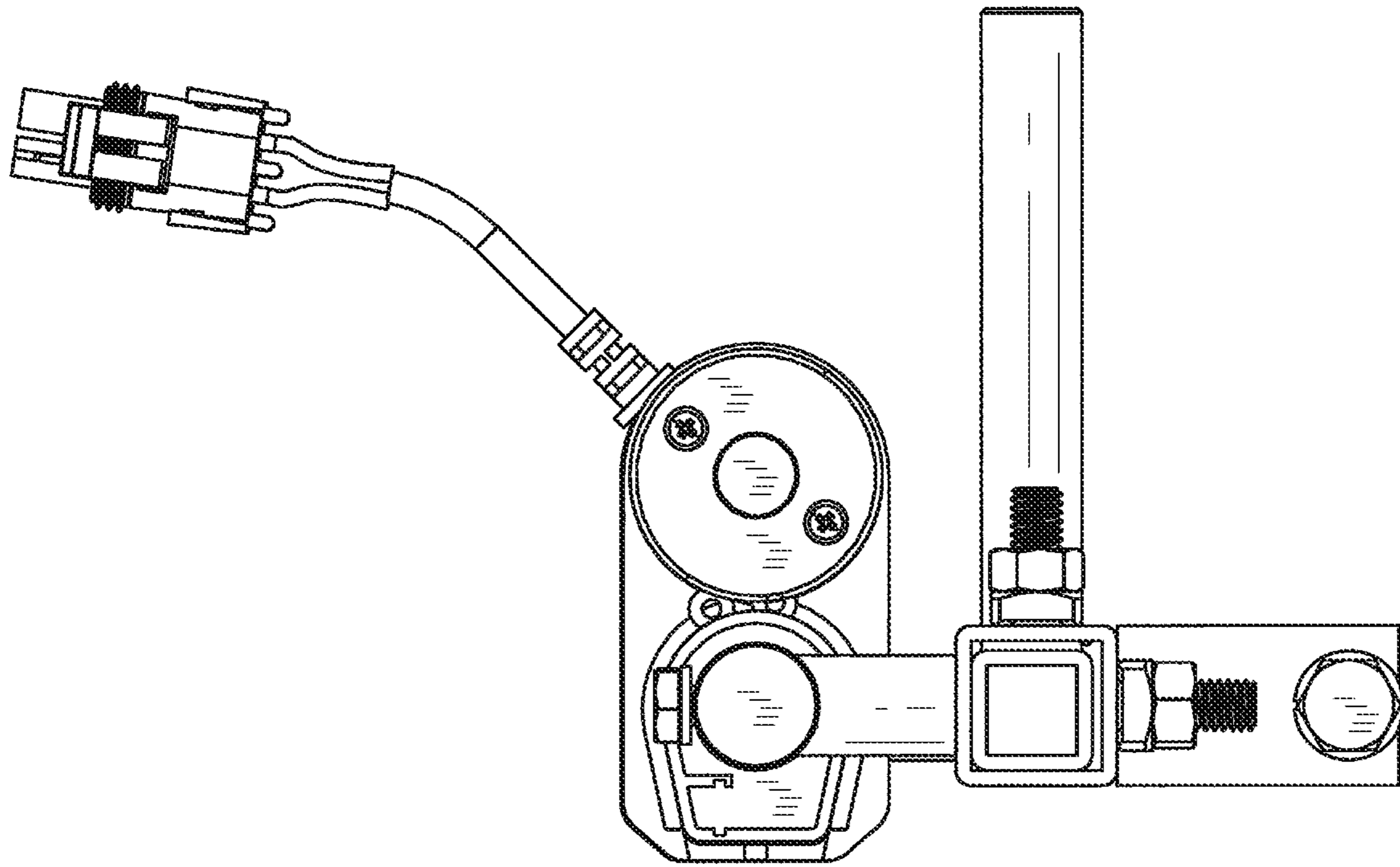

FIG. 6

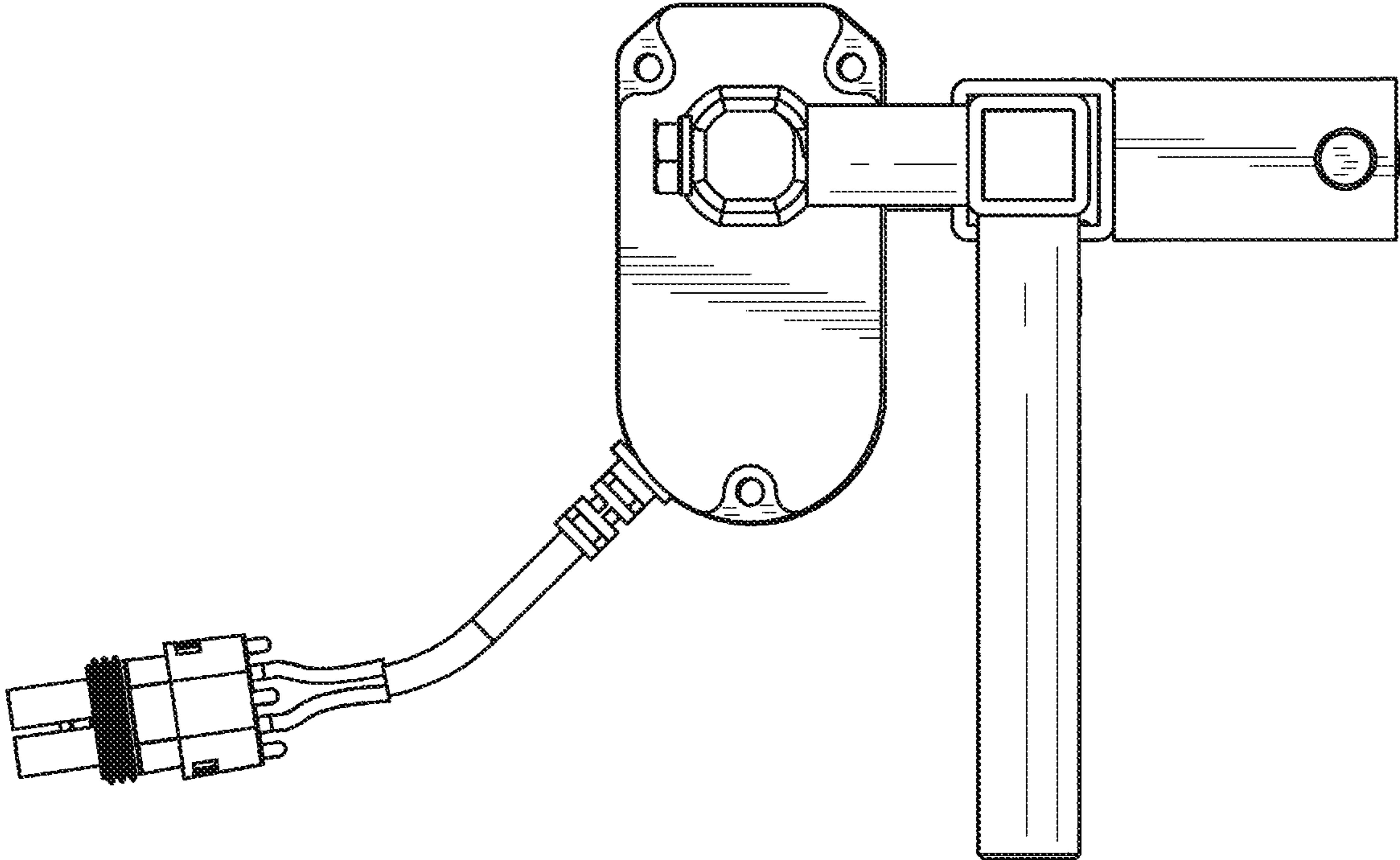

FIG. 7