



US00D888469S

(12) **United States Design Patent** (10) **Patent No.:** **US D888,469 S**  
**McDonald et al.** (45) **Date of Patent:** **\*\* Jun. 30, 2020**

- (54) **AUTOMATED RETAIL CABINET**
- (71) Applicant: **Stockwell AI Inc.**, Oakland, CA (US)
- (72) Inventors: **Paul Morell McDonald**, Diablo, CA (US); **Ashwath Natesh Rajan**, San Francisco, CA (US); **Tyler Harley Garvin**, San Francisco, CA (US); **Nichole Suzanne Rouillac**, San Francisco, CA (US); **Robin Nicholas Hubbard**, San Francisco, CA (US); **Niall D. Macken**, Santa Cruz, CA (US); **Giles M. Lowe**, San Jose, CA (US); **Arne Lang-Ree**, Los Gatos, CA (US)
- (73) Assignee: **Stockwell AI Inc.**, Oakland, CA (US)

(\*\*) Term: **15 Years**

(21) Appl. No.: **29/628,189**

(22) Filed: **Dec. 1, 2017**

(51) **LOC (12) Cl.** ..... **06-04**

(52) **U.S. Cl.**  
USPC ..... **D6/661**

(58) **Field of Classification Search**  
USPC ..... D6/657, 660, 662.1, 672, 675.1  
CPC ..... A47B 47/024; A47B 88/48; A47B 88/90;  
A47F 3/0413; A47F 5/116; A47F 5/0018;  
Y10T 428/24694; F25D 21/14; F25D  
23/069; F25D 2400/10  
See application file for complete search history.

(56) **References Cited**

**U.S. PATENT DOCUMENTS**

D56,556 S	*	11/1920	Gray	.....	D6/661
D116,224 S	*	8/1939	Erickson	.....	D6/675.1
D116,797 S	*	9/1939	Erickson	.....	D6/675.1
D124,551 S	*	1/1941	Doner	.....	D6/661
D126,206 S	*	4/1941	Johnson et al.	.....	D6/661
D126,207 S	*	4/1941	Johnson et al.	.....	D6/661
D126,208 S	*	4/1941	Johnson et al.	.....	D6/661
D127,208 S	*	5/1941	Johnson et al.	.....	D6/661

D172,116 S	*	5/1954	Weiss et al.	.....	D6/675.1
D252,722 S	*	8/1979	Hero	.....	D6/662.1
D314,090 S	*	1/1991	Stephens	.....	D6/657
D347,753 S	*	6/1994	Pauer	.....	D6/661
D358,277 S	*	5/1995	Frost, Jr.	.....	D6/661
D373,692 S	*	9/1996	Staeger	.....	D6/660
D541,080 S	*	4/2007	Thompson	.....	D6/661
D549,005 S	*	8/2007	Domack	.....	D6/660
D668,475 S	*	10/2012	Zambelli	.....	D6/661
D682,584 S	*	5/2013	Hansen, Jr.	.....	D6/675.1
D691,838 S	*	10/2013	Hinkle	.....	A47F 11/10 D6/675.1
D692,697 S	*	11/2013	Schmitt	.....	D6/661
D693,156 S	*	11/2013	Hamm	.....	D6/672
D717,081 S	*	11/2014	Dworman	.....	D6/657
D728,283 S	*	5/2015	Weshler	.....	D6/675.1
D734,068 S	*	7/2015	Dworman	.....	D6/662.1
D757,465 S	*	5/2016	Woelfel	.....	D6/672
D776,466 S	*	1/2017	Bonuccelli	.....	D6/675.1
D785,978 S	*	5/2017	Brown	.....	D6/675.1

\* cited by examiner

*Primary Examiner* — Kevin K Rudzinski

*Assistant Examiner* — Paul D Bohannon

(74) *Attorney, Agent, or Firm* — Weaver Austin Villeneuve & Sampson LLP

(57) **CLAIM**

We claim the ornamental design for an automated retail cabinet, as shown and described.

**DESCRIPTION**

FIG. 1 depicts an isometric view of an automated retail cabinet.

FIG. 2 is a right side view of the automated retail cabinet of FIG. 1.

FIG. 3 is a left side view of the automated retail cabinet of FIG. 1; the right and left side views are mirror images of each other.

FIG. 4 is front view of the automated retail cabinet of FIG. 1.

FIG. 5 is a top view of the automated retail cabinet of FIG. 1.

FIG. 6 is a back view of the automated retail cabinet of FIG. 1.

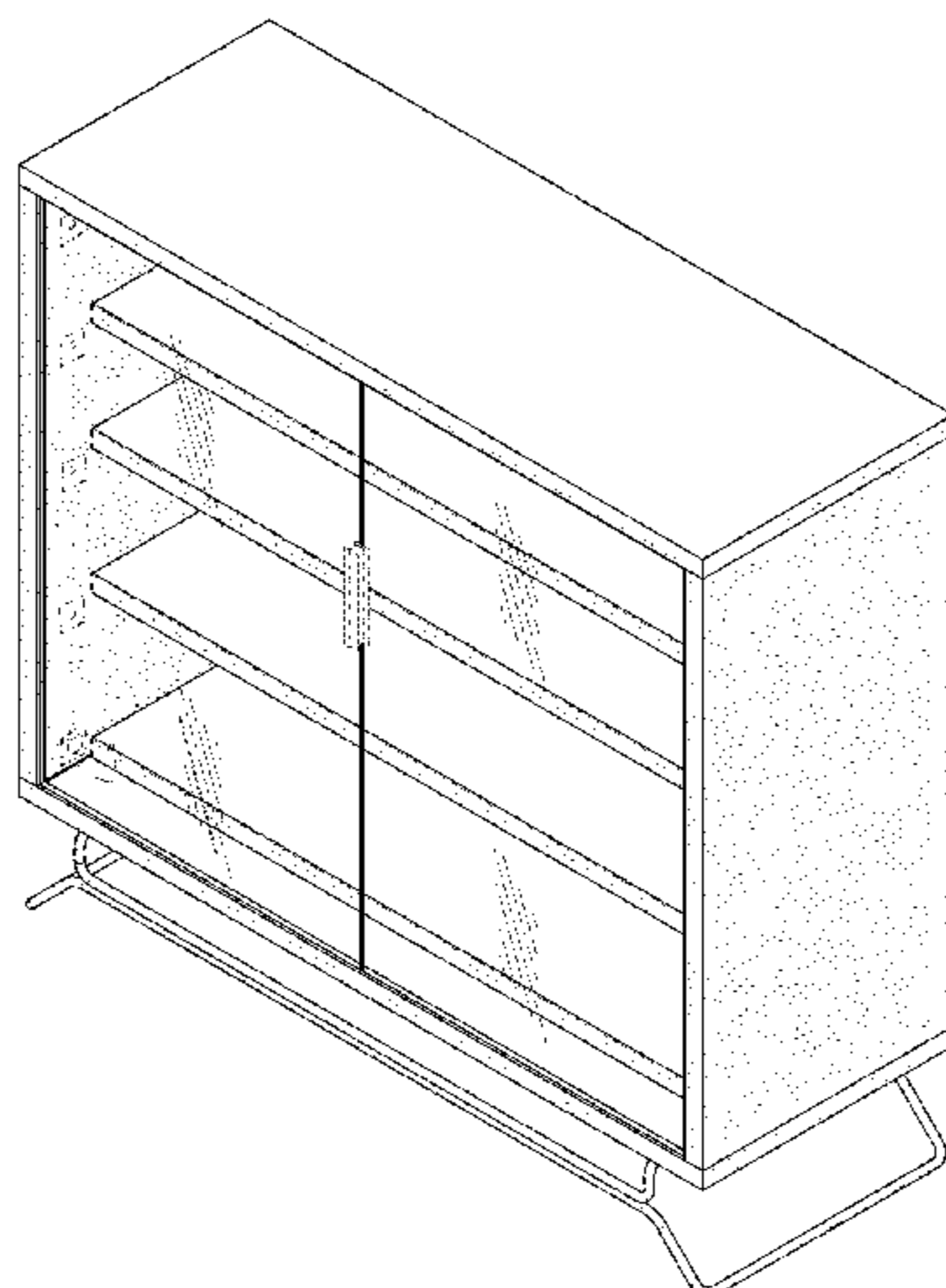

FIG. 7 is a bottom view of the automated retail cabinet of FIG. 1.

FIG. 8 is a bottom perspective view of the automated retail cabinet of FIG. 1.

FIG. 9 is a top perspective view of the automated retail cabinet of FIG. 1.

FIG. 10 is another bottom perspective view of the automated retail cabinet of FIG. 1.

FIG. 11 is the isometric view of the automated retail cabinet of FIG. 1 with one door in an open position.

FIG. 12 depicts the isometric view of the automated retail cabinet of FIG. 1 with darker shading; this Figure represents the first step in a light-up sequence in which one or more illumination sources within the automated retail cabinet are illuminated in a particular order set forth in FIGS. 12-21; FIGS. 12-16 depict the light-up sequence from the isometric view while FIGS. 17-21 depict the same light-up sequence from the front view.

FIG. 13 depicts the isometric view of the automated retail cabinet of FIG. 12 with one shelf illuminated more than the other shelves in the automated retail cabinet; this Figure represents the second step in the light-up sequence.

FIG. 14 depicts the isometric view of the automated retail cabinet of FIG. 12 with two shelves illuminated more than the other shelves in the automated retail cabinet; this Figure represents the third step in the light-up sequence.

FIG. 15 depicts the isometric view of the automated retail cabinet of FIG. 12 with three shelves illuminated more than the other shelf in the automated retail cabinet; this Figure represents the fourth step in the light-up sequence.

FIG. 16 depicts the isometric view of the automated retail cabinet of FIG. 12 with four shelves illuminated the same amount; this Figure represents the fifth step in the light-up sequence.

FIG. 17 depicts the front view of the automated retail cabinet of FIG. 4 with darker shading and depicts the same first step of the light-up sequence as FIG. 12, but from the front view.

FIG. 18 depicts the front view of the automated retail cabinet of FIG. 17 with one shelf illuminated more than the other shelves in the automated retail cabinet; this Figure depicts the same second step of the light-up sequence as FIG. 13, but from the front view.

FIG. 19 depicts the front view of the automated retail cabinet of FIG. 17 with two shelves illuminated more than the other shelves in the automated retail cabinet; this Figure depicts the same third step of the light-up sequence as FIG. 14, but from the front view.

FIG. 20 depicts the front view of the automated retail cabinet of FIG. 17 with three shelves illuminated more than the other shelf in the automated retail cabinet; this Figure depicts the same fourth step of the light-up sequence as FIG. 15, but from the front view.

FIG. 21 depicts the front view of the automated retail cabinet of FIG. 17 with four shelves illuminated the same amount; this Figure depicts the same fifth step of the light-up sequence as FIG. 16, but from the front view.

FIG. 22 depicts the front view of the automated retail cabinet of FIG. 4 with darker shading and depicts the first step of a second light-up sequence; FIGS. 22-26 depict, in order, the second light-up sequence.

FIG. 23 depicts the front view of the automated retail cabinet of FIG. 24 with one shelf illuminated more than the other shelves in the automated retail cabinet; this Figure depicts the second step of second light-up sequence.

FIG. 24 depicts the front view of the automated retail cabinet of FIG. 24 with two shelves illuminated more than the other shelves in the automated retail cabinet; this Figure depicts the third step of the second light-up sequence.

FIG. 25 depicts the front view of the automated retail cabinet of FIG. 24 with three shelves illuminated more than the other shelf in the automated retail cabinet; this Figure depicts the fourth step of the second light-up sequence.

FIG. 26 depicts the front view of the automated retail cabinet of FIG. 24 with four shelves illuminated the same amount; this Figure depicts the fifth step of the second light-up sequence.

FIG. 27 depicts the front view of the automated retail cabinet of FIG. 4 with darker shading and depicts the first step of a third light-up sequence; FIGS. 27-31 depict, in order, the third light-up sequence; it should also be noted that the third light-up sequence may have a sixth step in which all of the shelves are illuminated the same, as depicted in FIGS. 26 and 21.

FIG. 28 depicts the front view of the automated retail cabinet of FIG. 27 with one shelf illuminated more than the other shelves in the automated retail cabinet; this Figure depicts the second step of third light-up sequence.

FIG. 29 depicts the front view of the automated retail cabinet of FIG. 27 with a second shelf illuminated more than the other shelves in the automated retail cabinet; this Figure depicts the third step of the third light-up sequence.

FIG. 30 depicts the front view of the automated retail cabinet of FIG. 27 with a third shelf illuminated more than the other shelves in the automated retail cabinet; this Figure depicts the fourth step of the third light-up sequence.

FIG. 31 depicts the front view of the automated retail cabinet of FIG. 27 with a fourth shelf illuminated more than the other shelves; this Figure depicts the fifth step of the third light-up sequence.

FIG. 32 depicts the front view of the automated retail cabinet of FIG. 4 with darker shading and depicts the first step of a fourth light-up sequence; FIGS. 32-36 depict, in order, the fourth light-up sequence; it should also be noted that the fourth light-up sequence may have a sixth step in which all of the shelves are illuminated the same, as depicted in FIGS. 26 and 21.

FIG. 33 depicts the front view of the automated retail cabinet of FIG. 32 with one shelf illuminated more than the other shelves in the automated retail cabinet; this Figure depicts the second step of fourth light-up sequence.

FIG. 34 depicts the front view of the automated retail cabinet of FIG. 32 with a second shelf illuminated more than the other shelves in the automated retail cabinet; this Figure depicts the third step of the fourth light-up sequence.

FIG. 35 depicts the front view of the automated retail cabinet of FIG. 32 with a third shelf illuminated more than the other shelves in the automated retail cabinet; this Figure depicts the fourth step of the fourth light-up sequence.

FIG. 36 depicts the front view of the automated retail cabinet of FIG. 32 with a fourth shelf illuminated more than the other shelves; this Figure depicts the fifth step of the fourth light-up sequence.

FIG. 37 is the front view of the automated retail cabinet of FIG. 4 with section line A-A indicating a section plane for FIGS. 38 and 39.

FIG. 38 is a bottom perspective section view of the automated retail cabinet of FIG. 4; and,

FIG. 39 is a left side elevation section view of the automated retail cabinet of FIG. 4.

An automated retail cabinet is described and claimed. Stipple shading is used in accompanying FIGS. 1-11 and 37 to convey surface shading and contouring, and not texture. In FIGS. 12-36, stipple shading is used to depict illumination, as described above.

The broken lines shown in the Drawings represent portions of the automated retail cabinet that form no part of the claimed design.

**1 Claim, 34 Drawing Sheets**

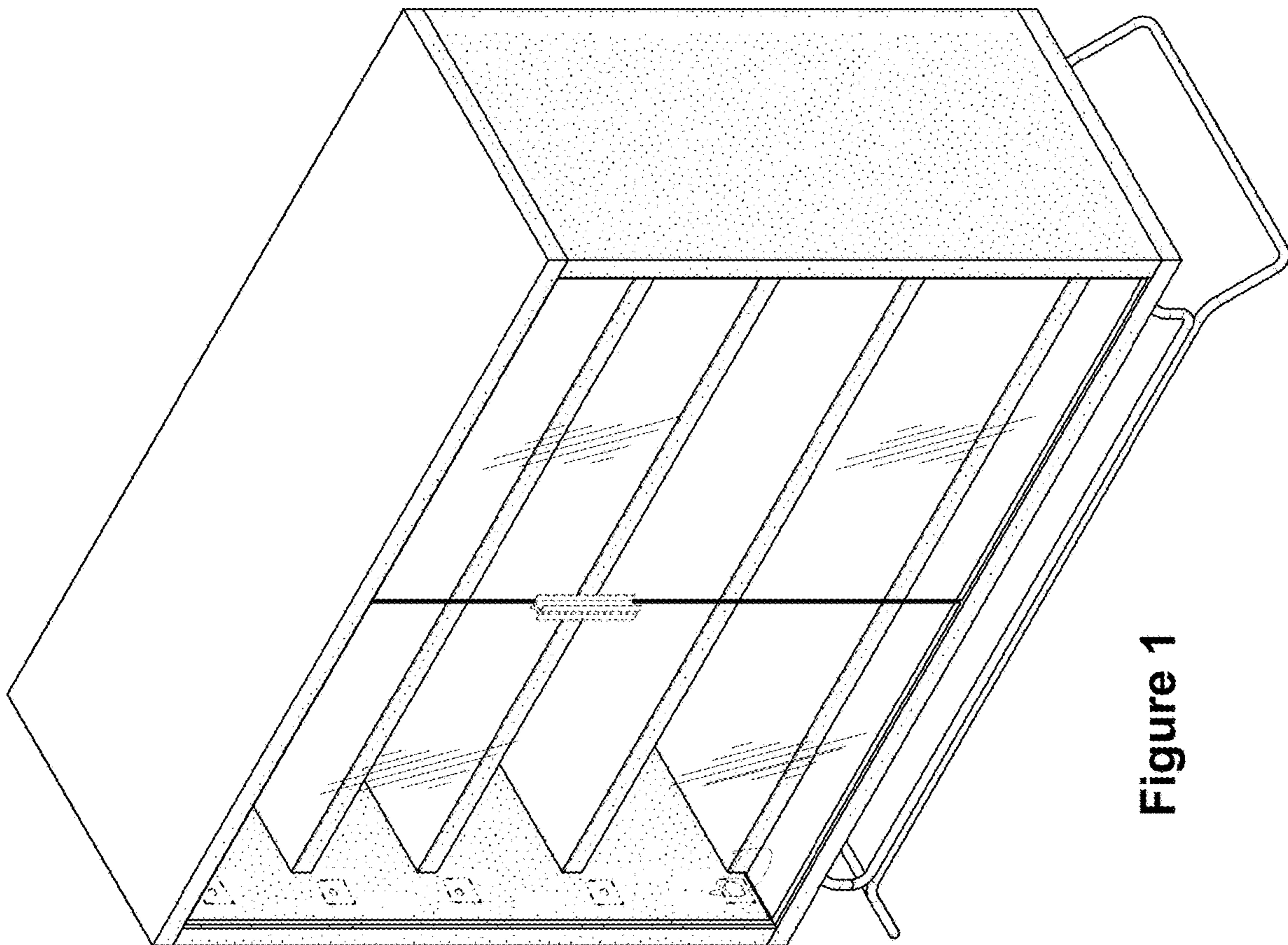

Figure 1

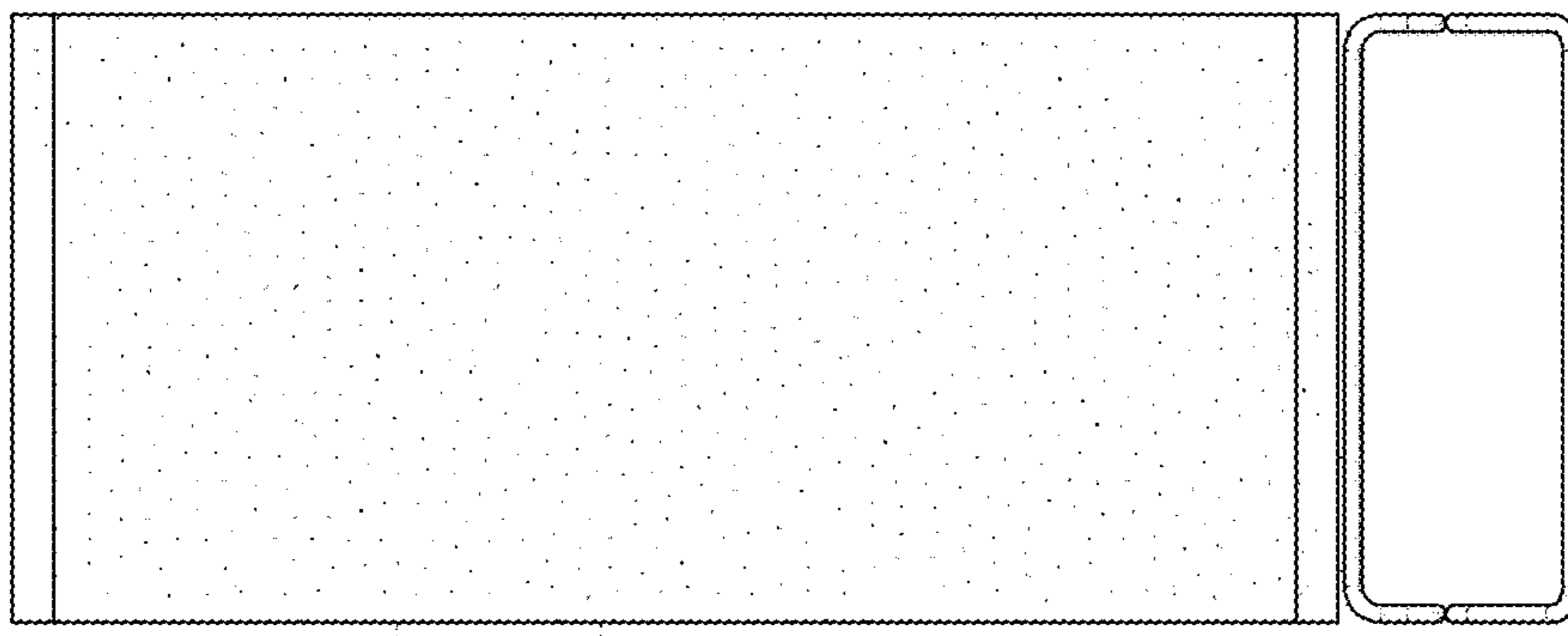

Figure 2

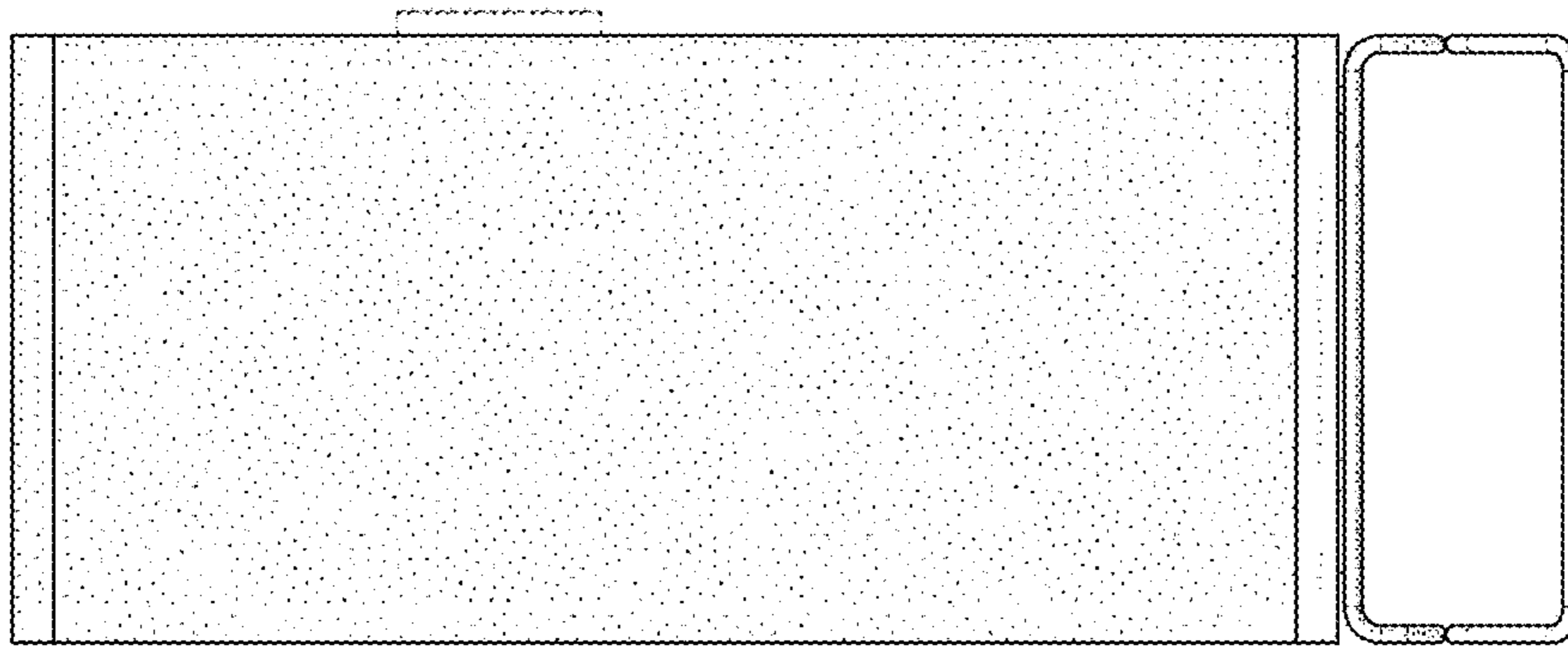

Figure 3

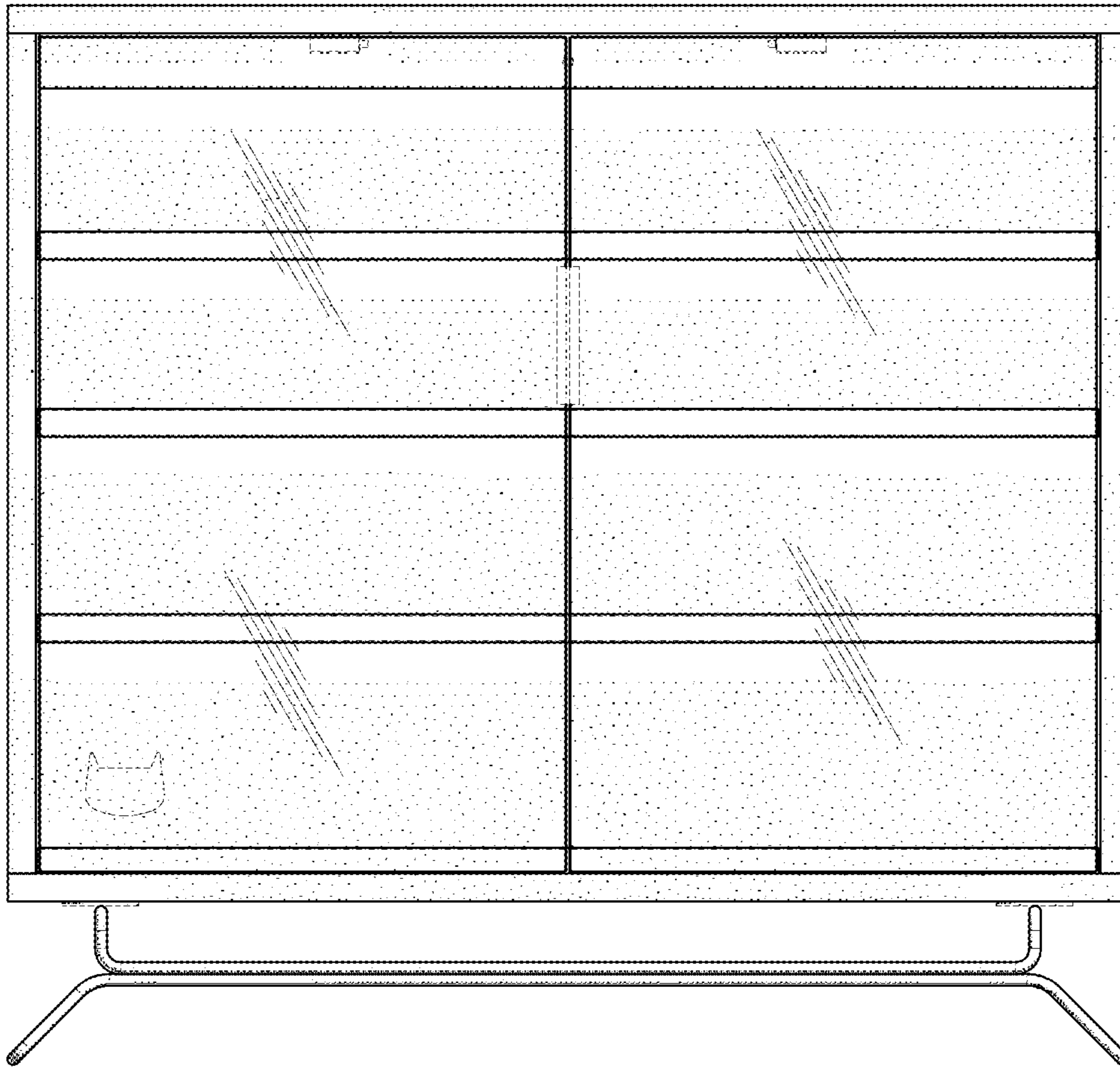

Figure 4

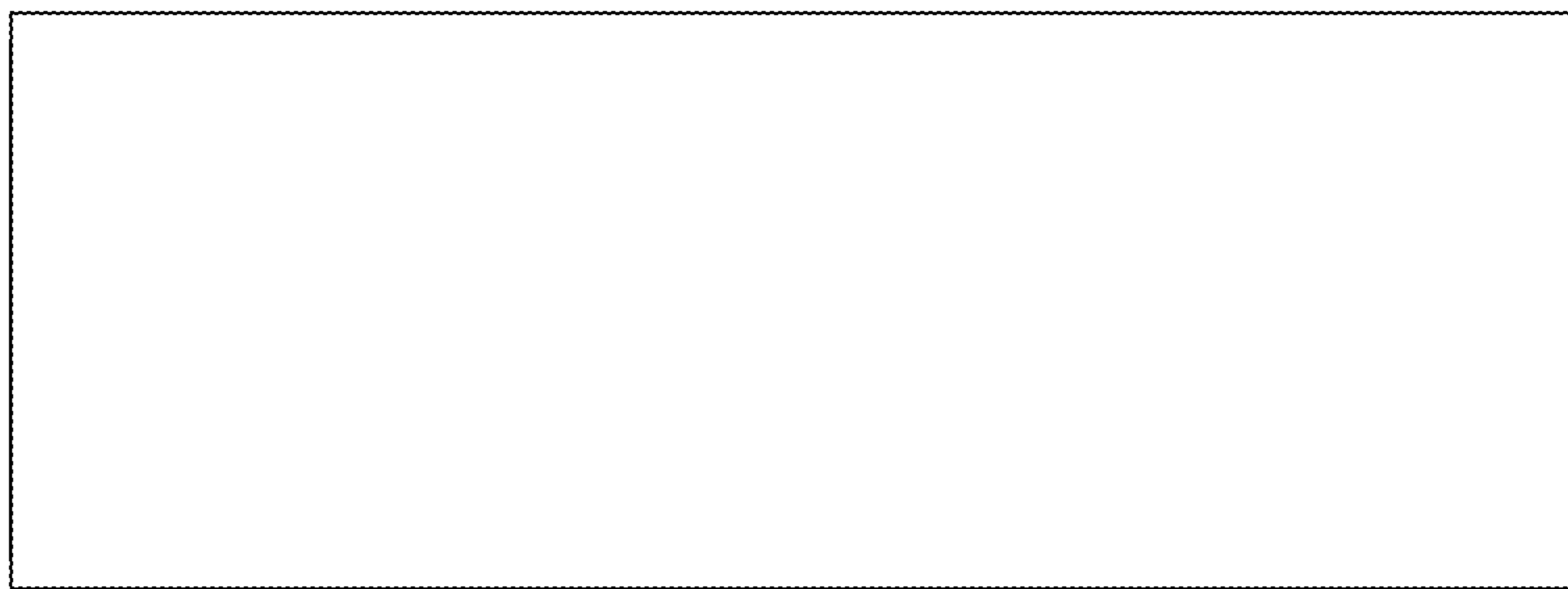

Figure 5

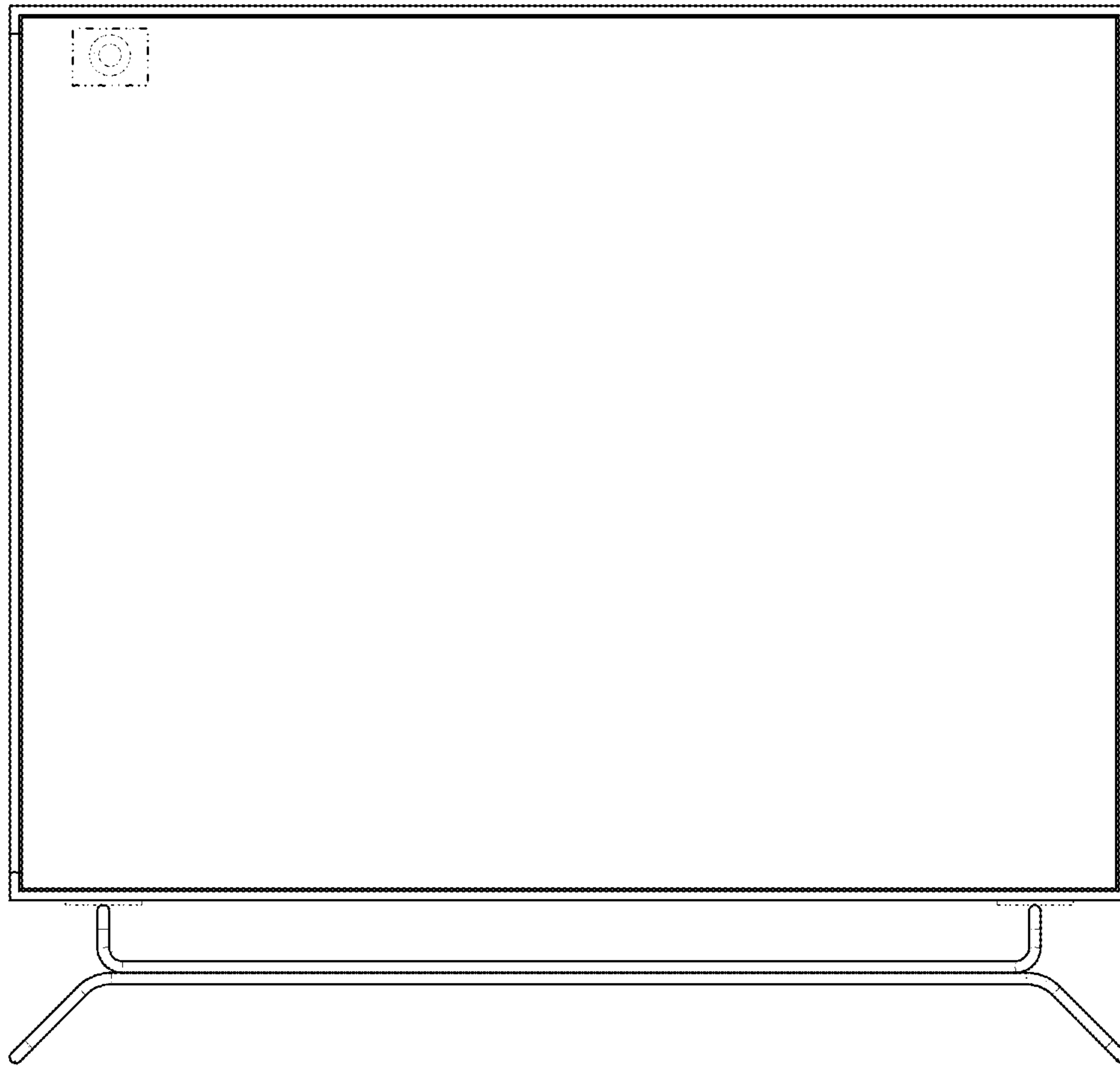

Figure 6

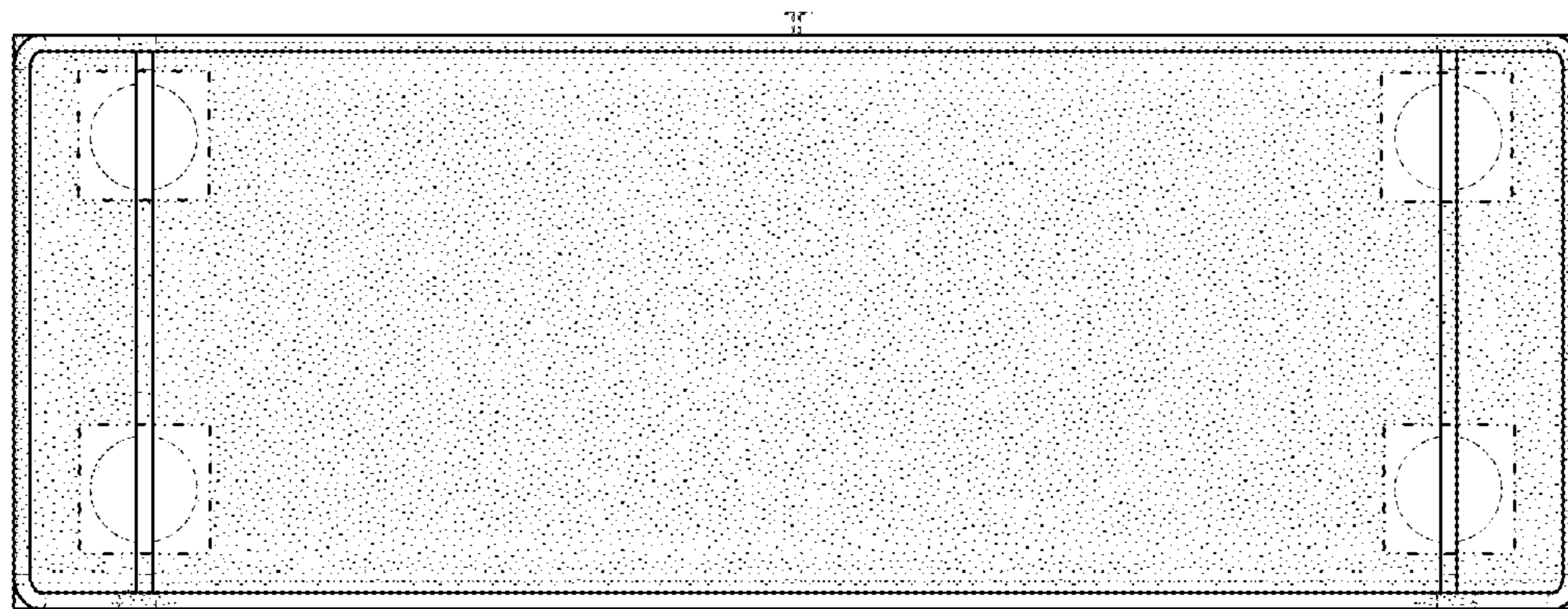

Figure 7

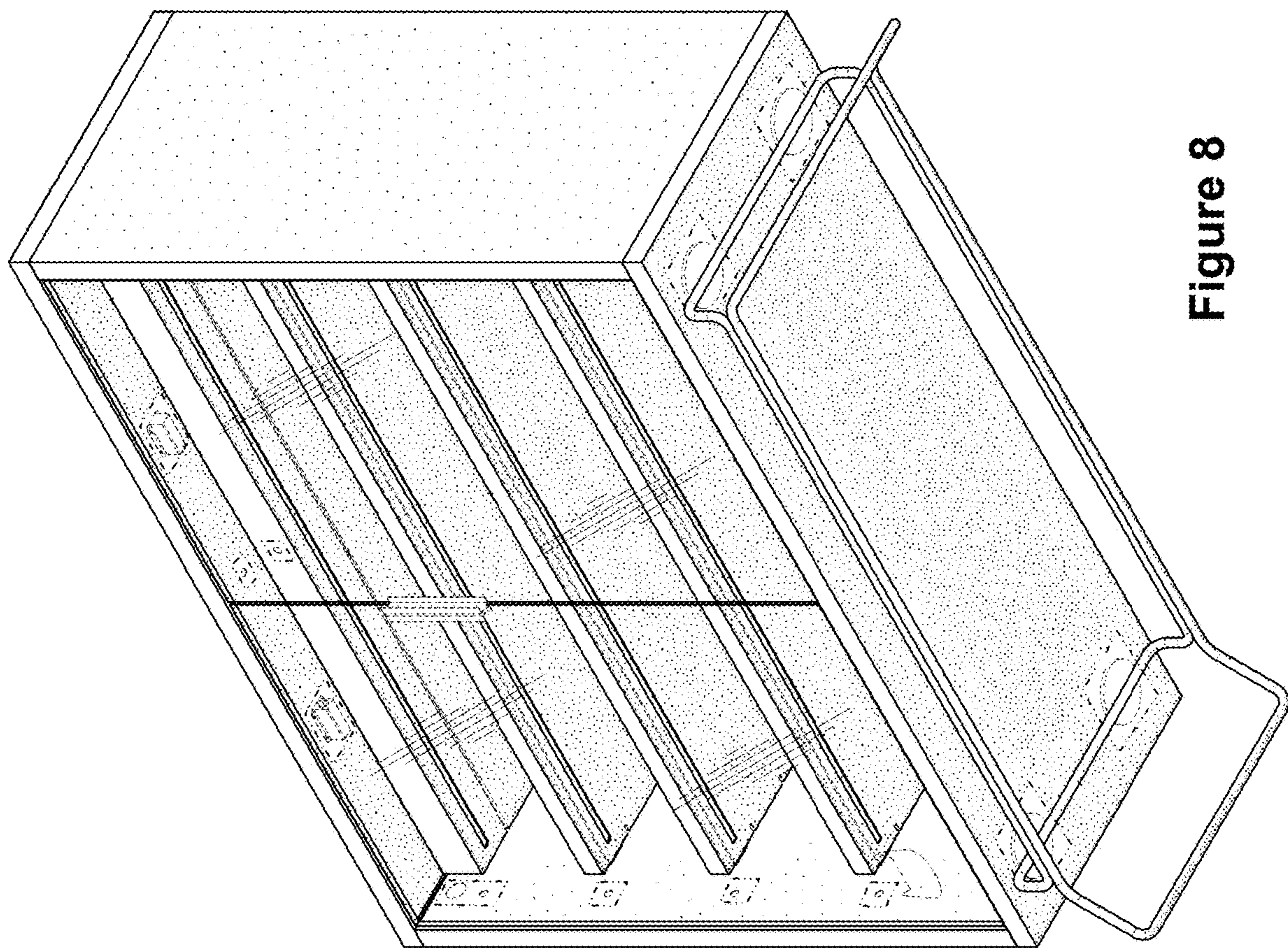

Figure 8

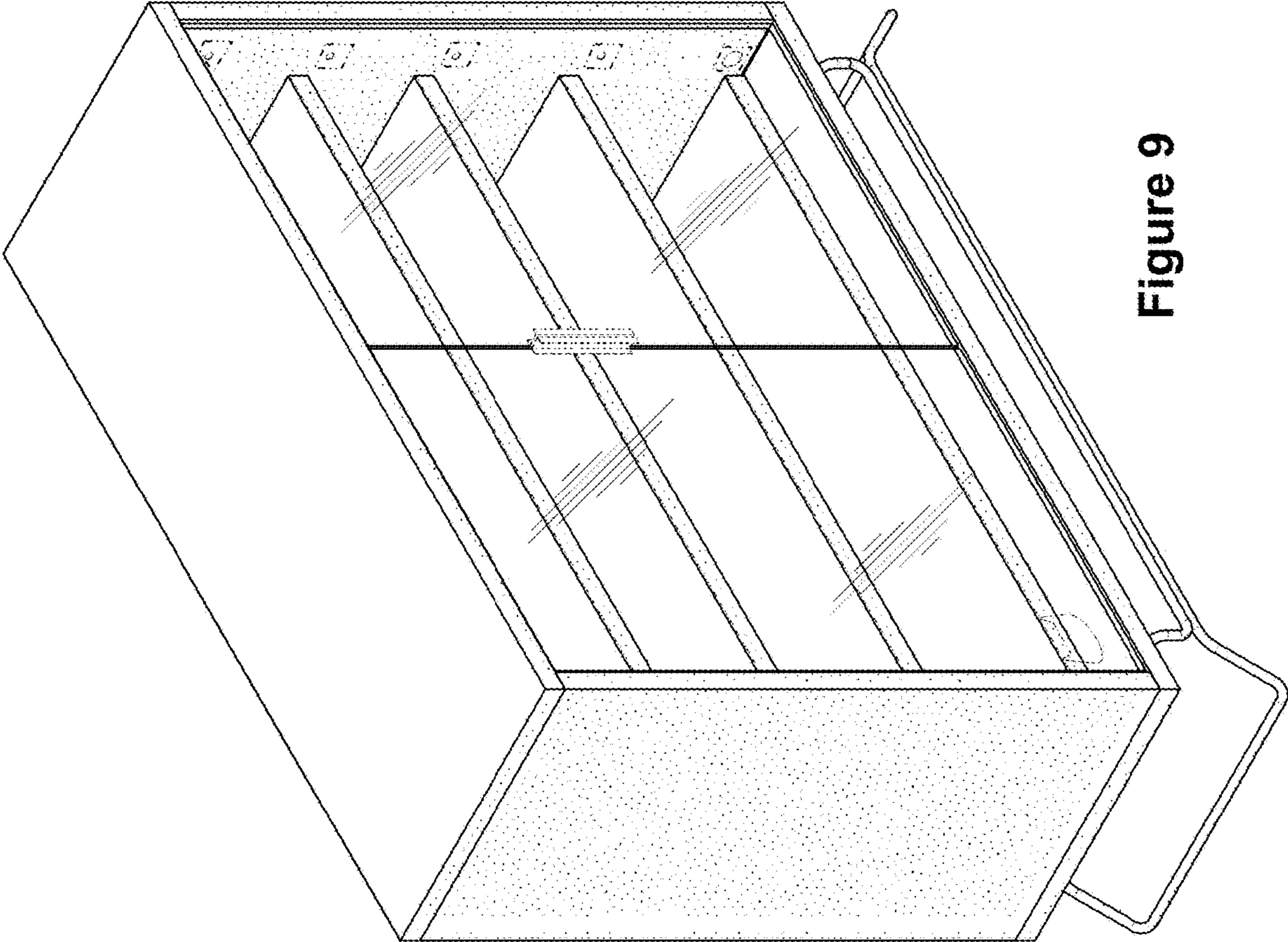

Figure 9



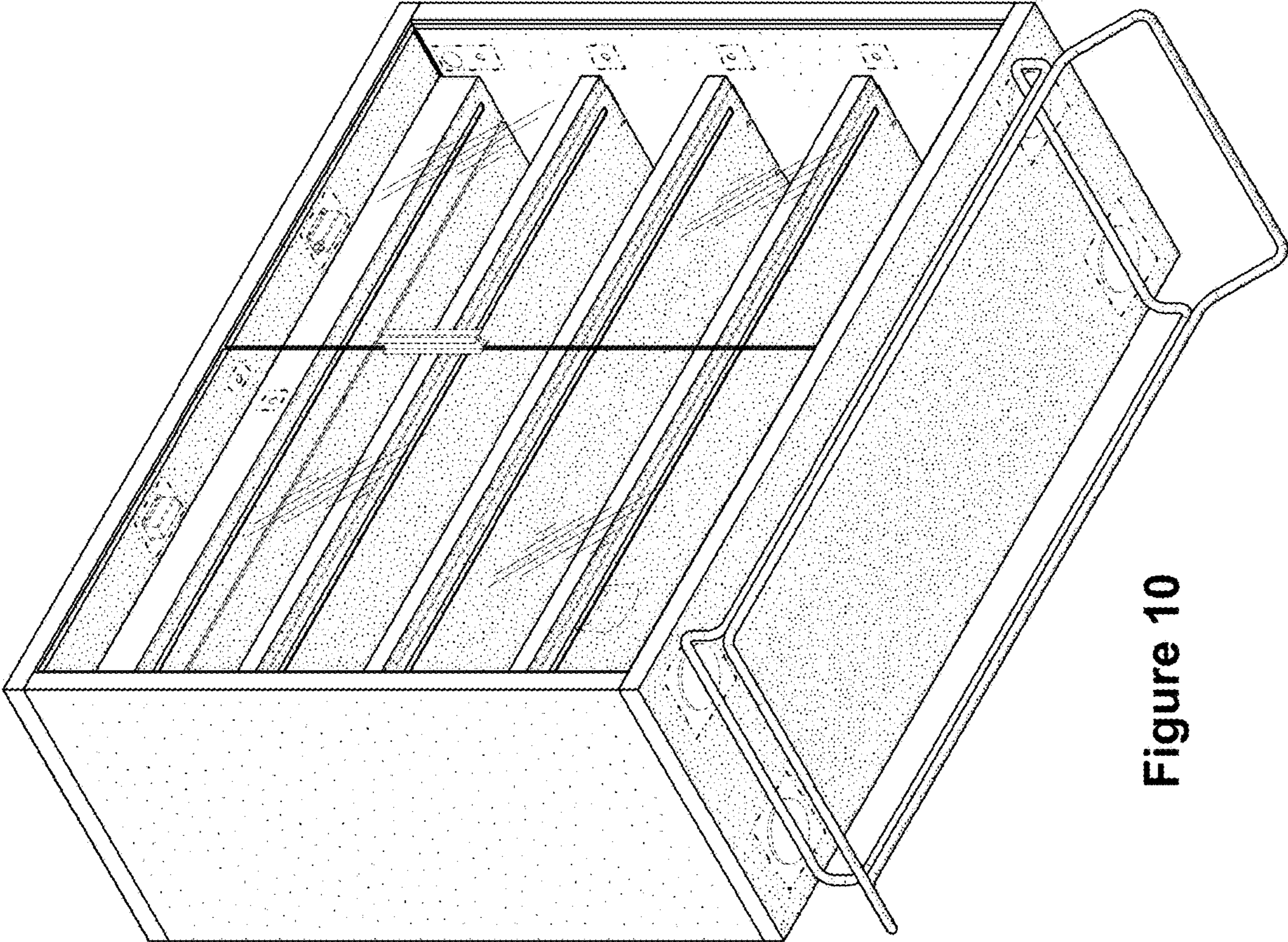

Figure 10

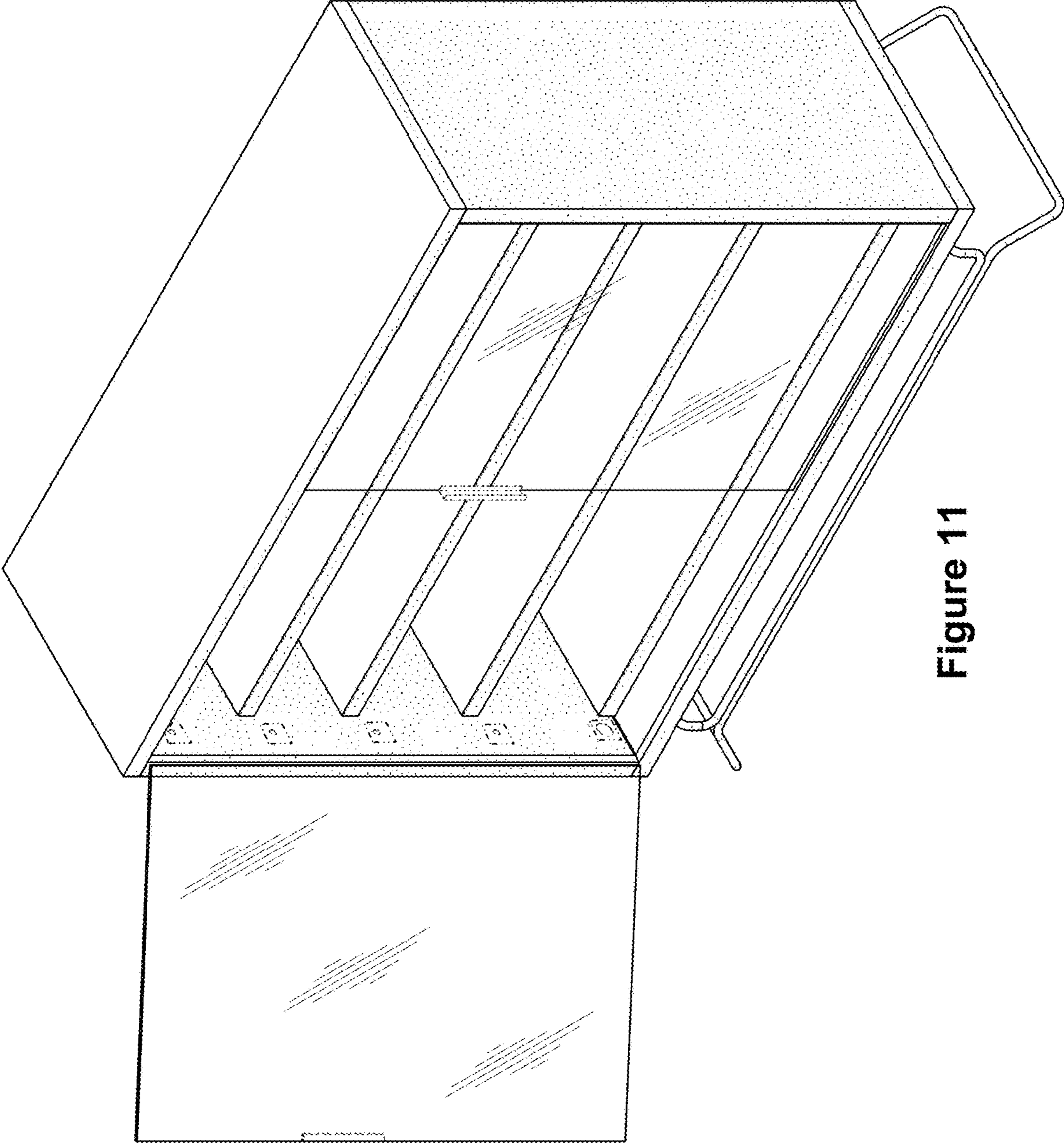

Figure 11

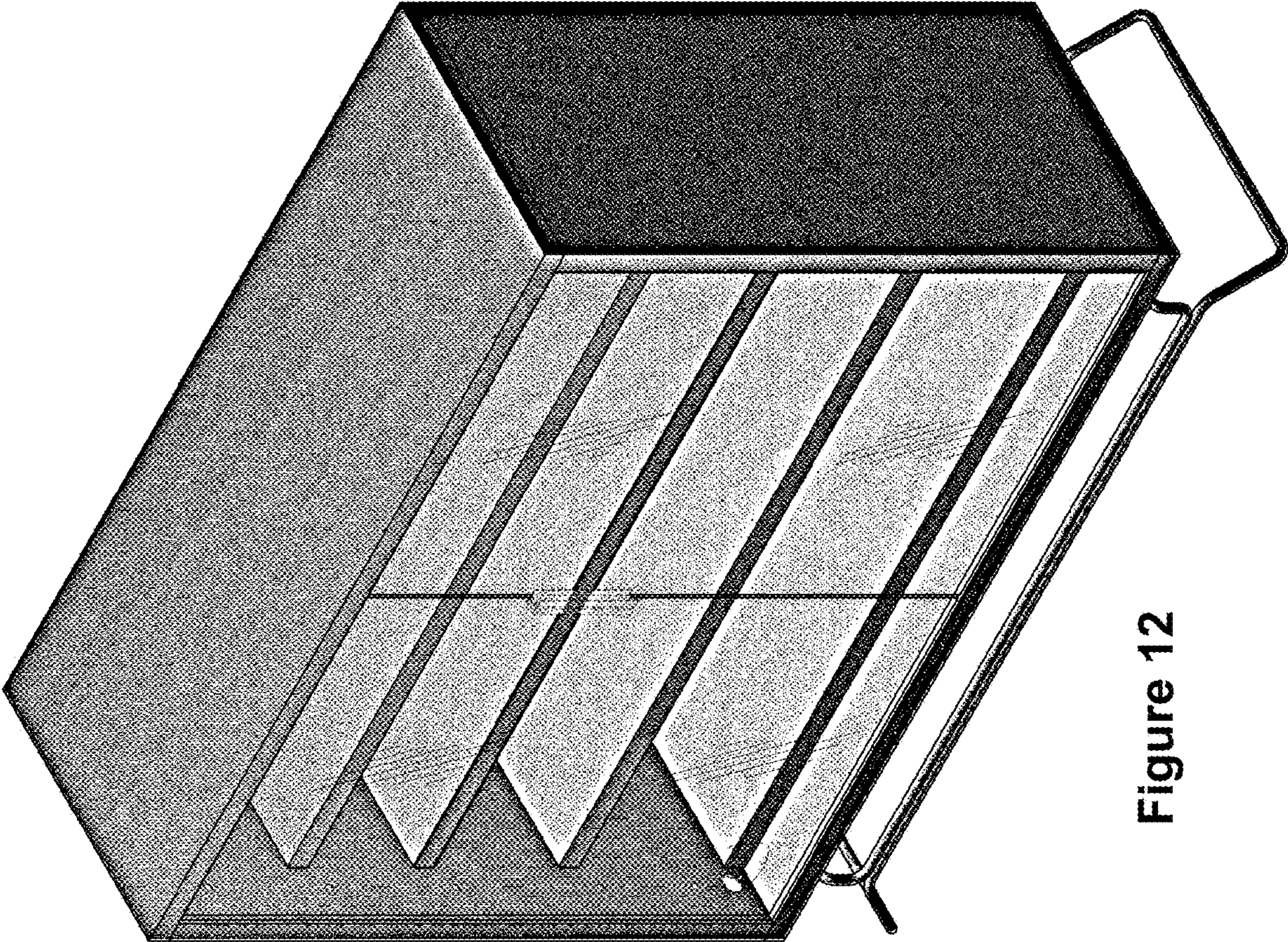

Figure 12

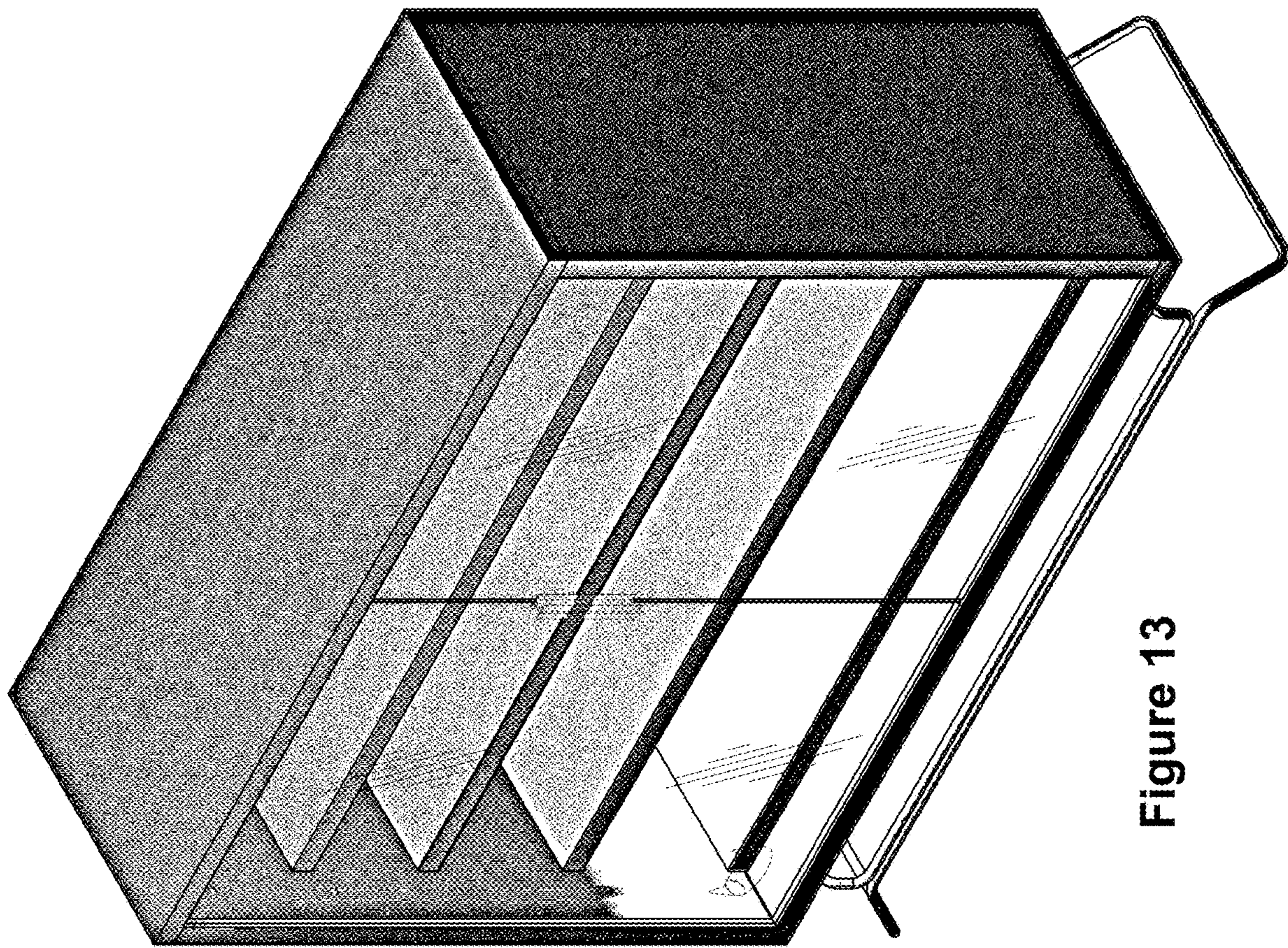

Figure 13

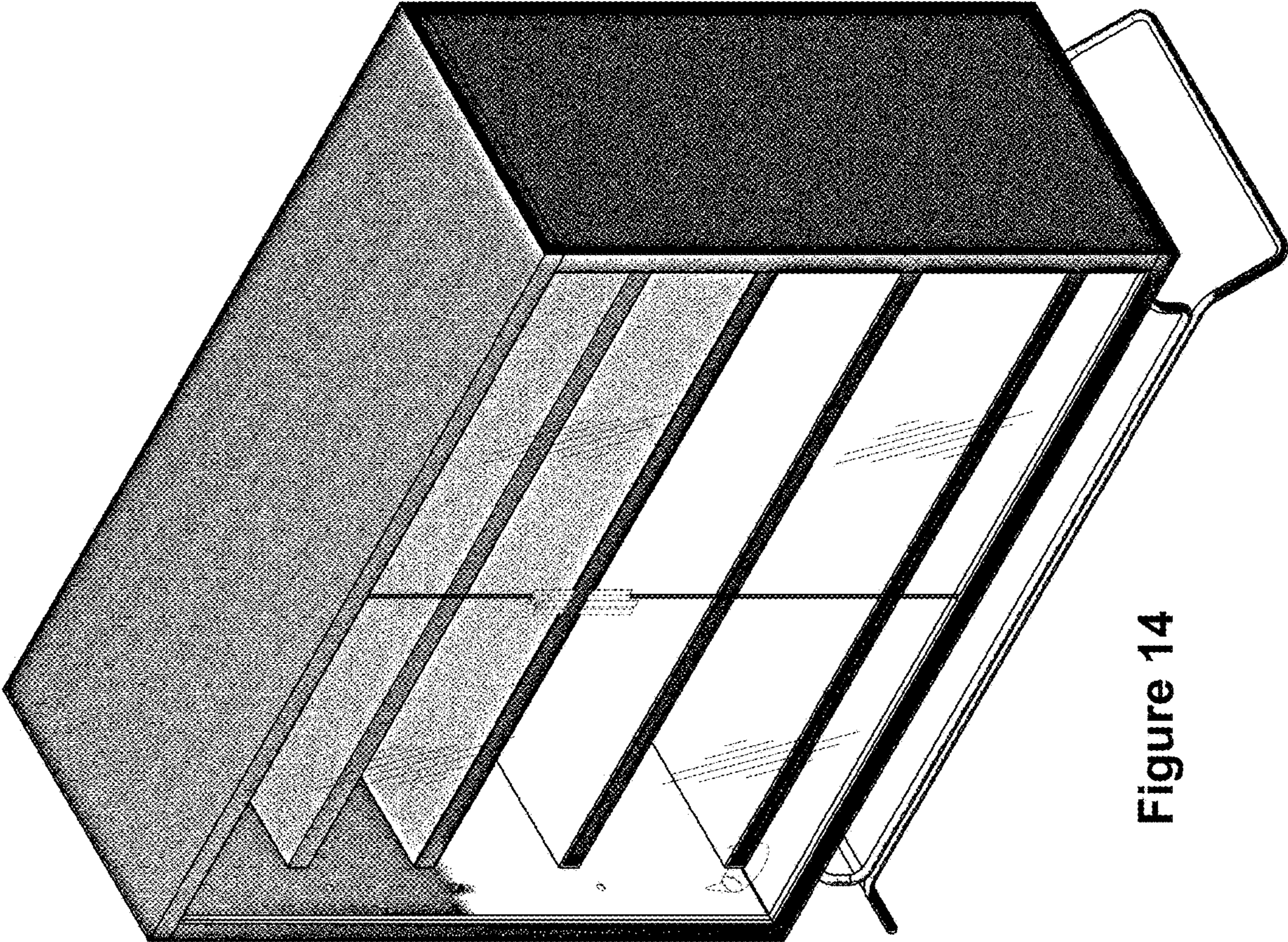

Figure 14

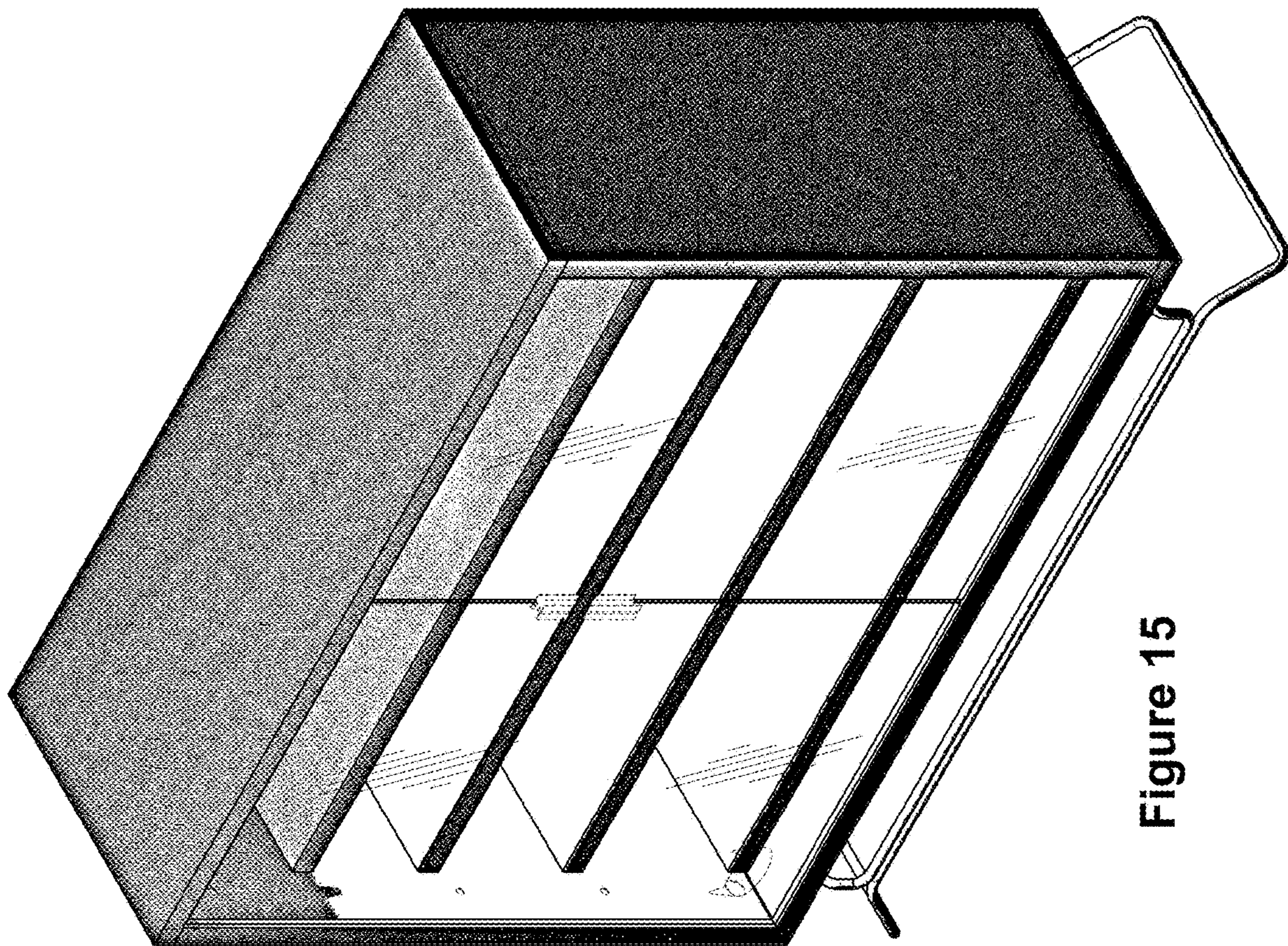

Figure 15

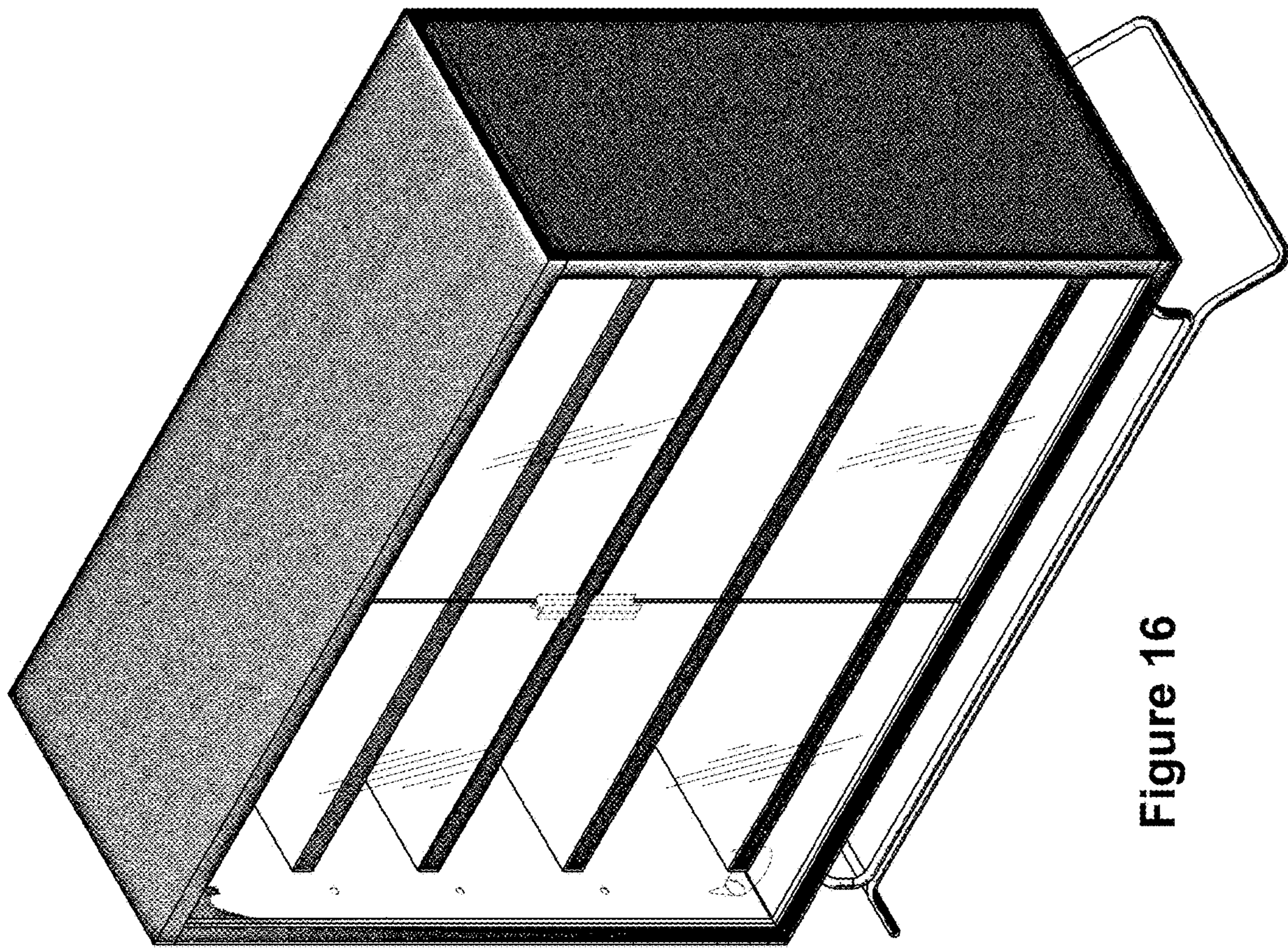

Figure 16

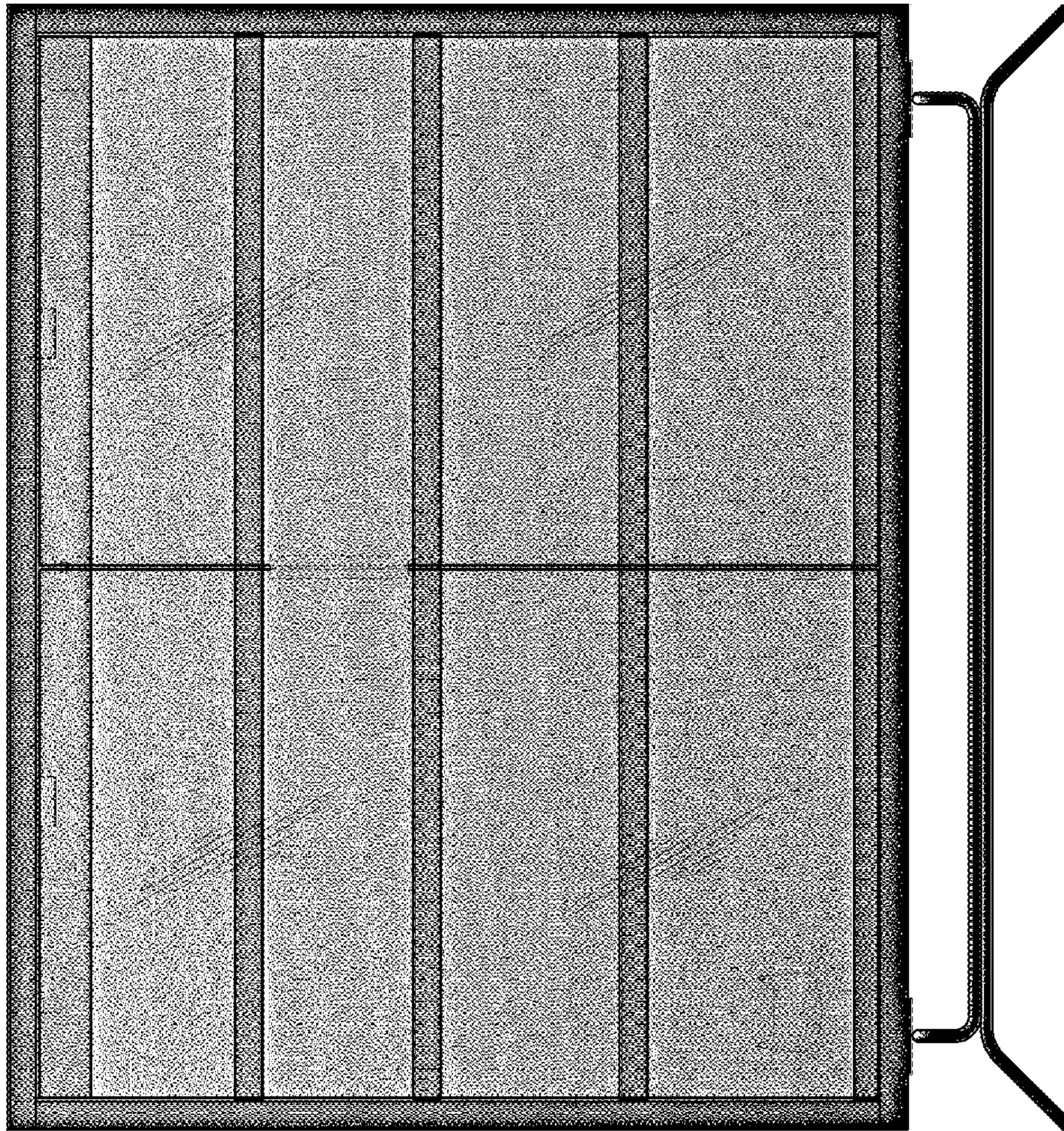

Figure 17



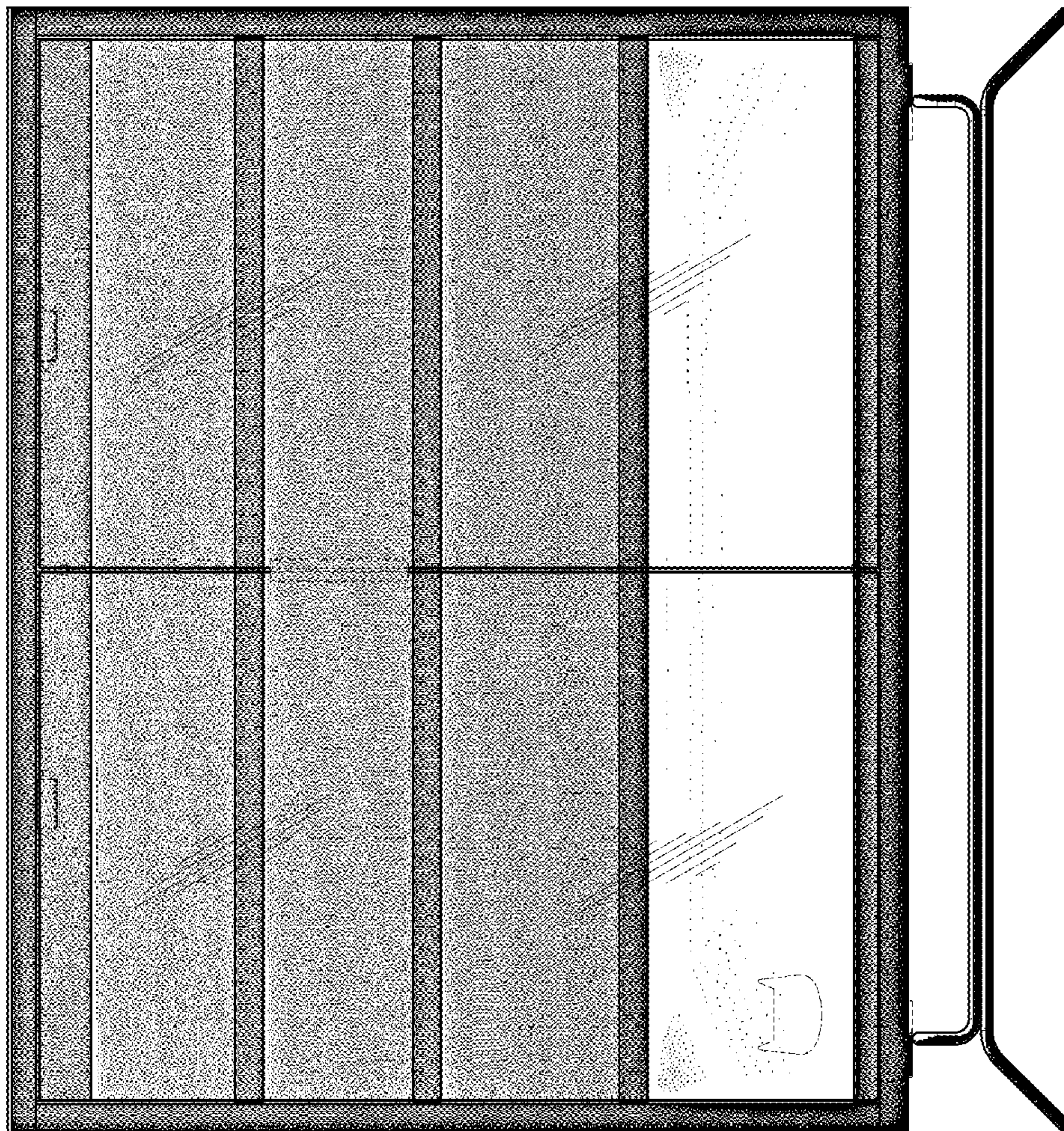

Figure 18

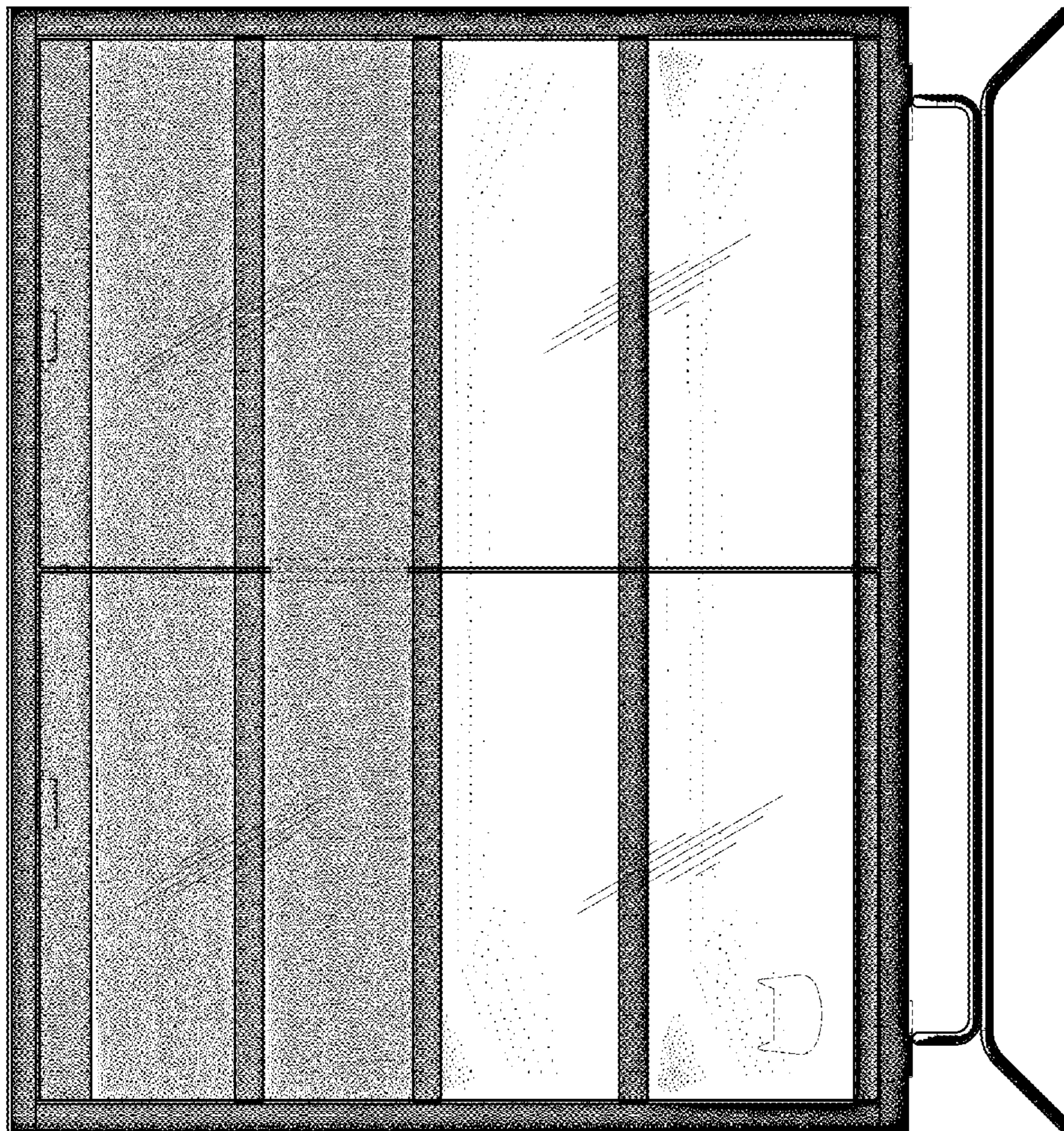

Figure 19

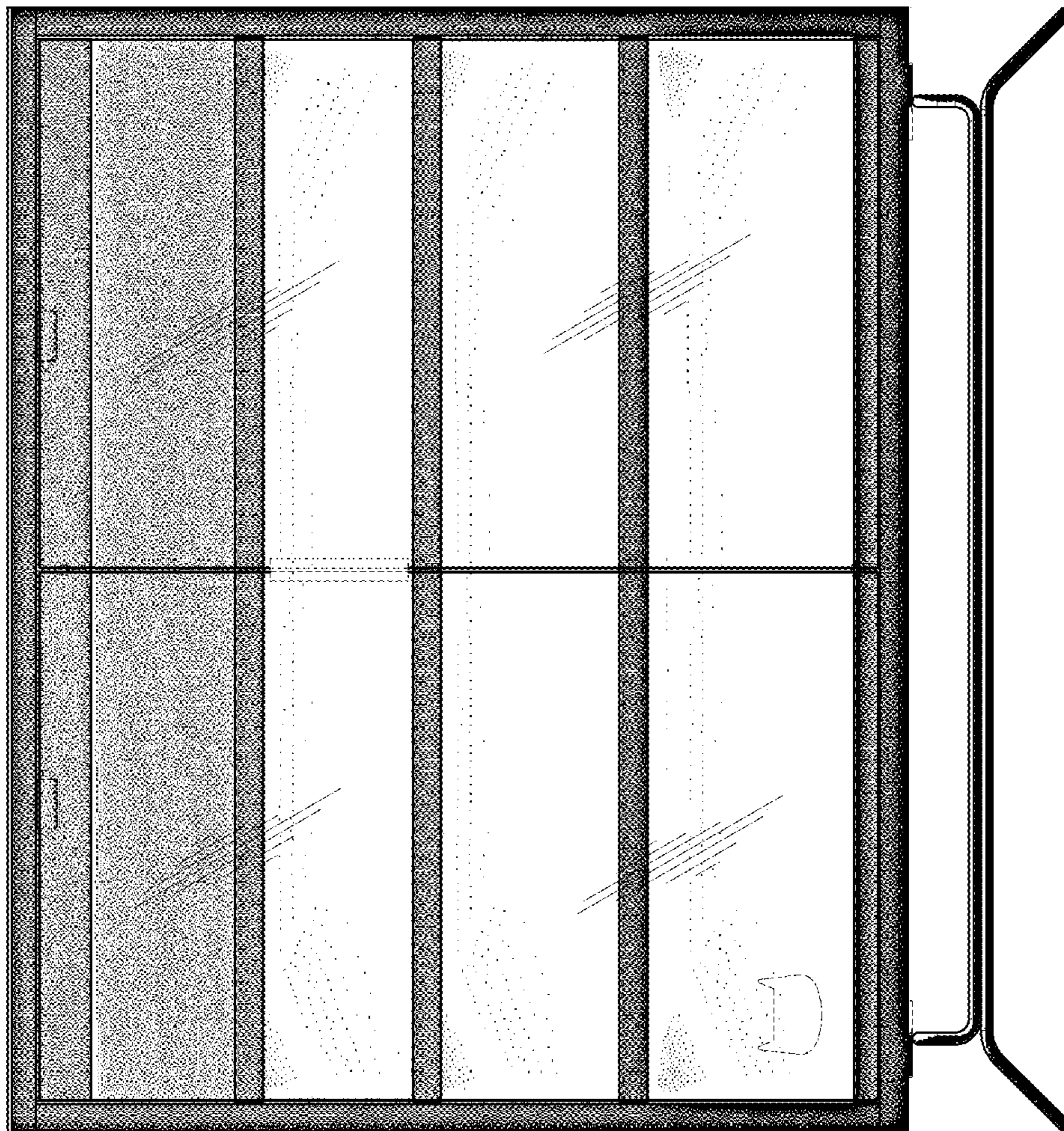

Figure 20

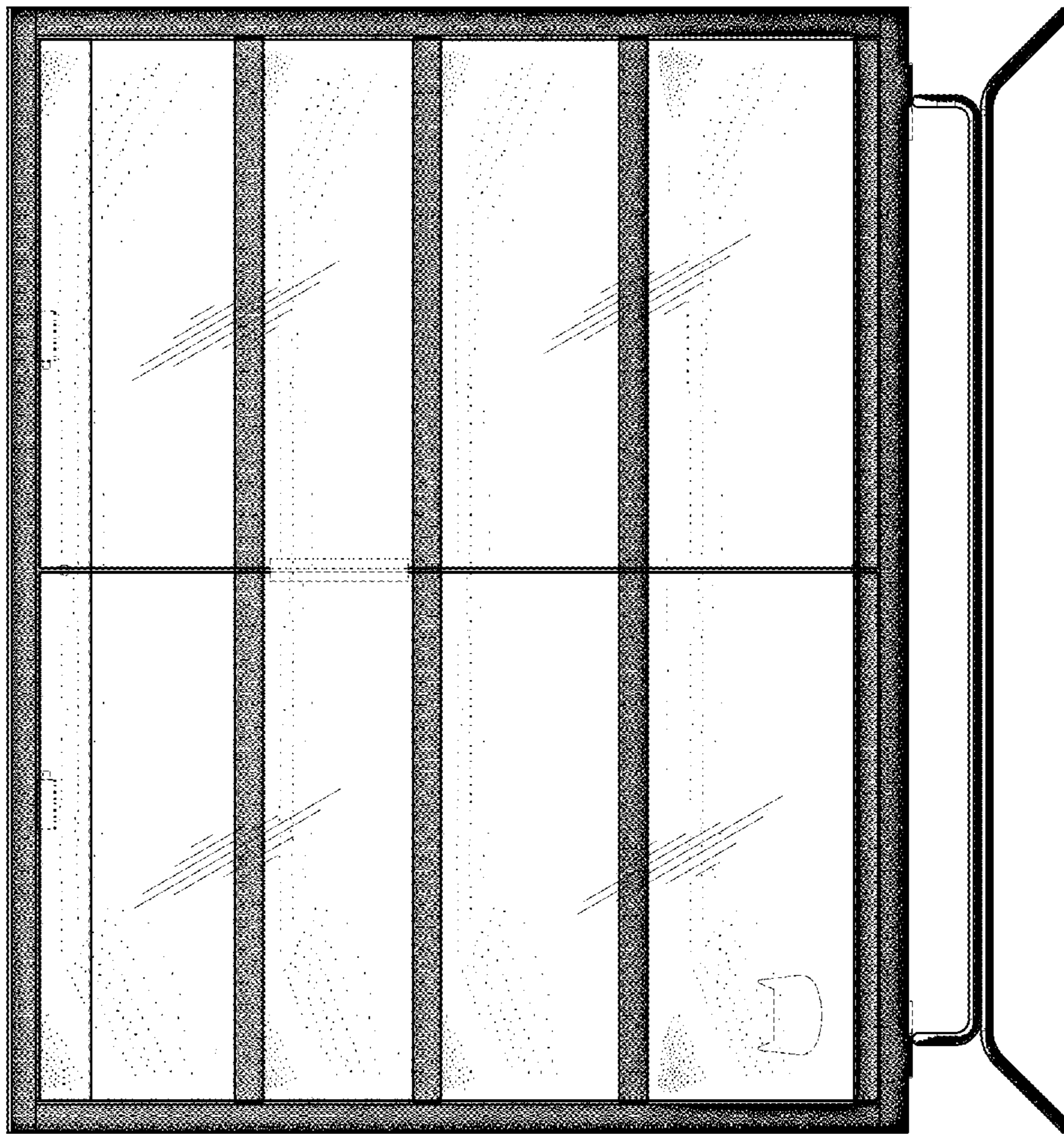

Figure 21

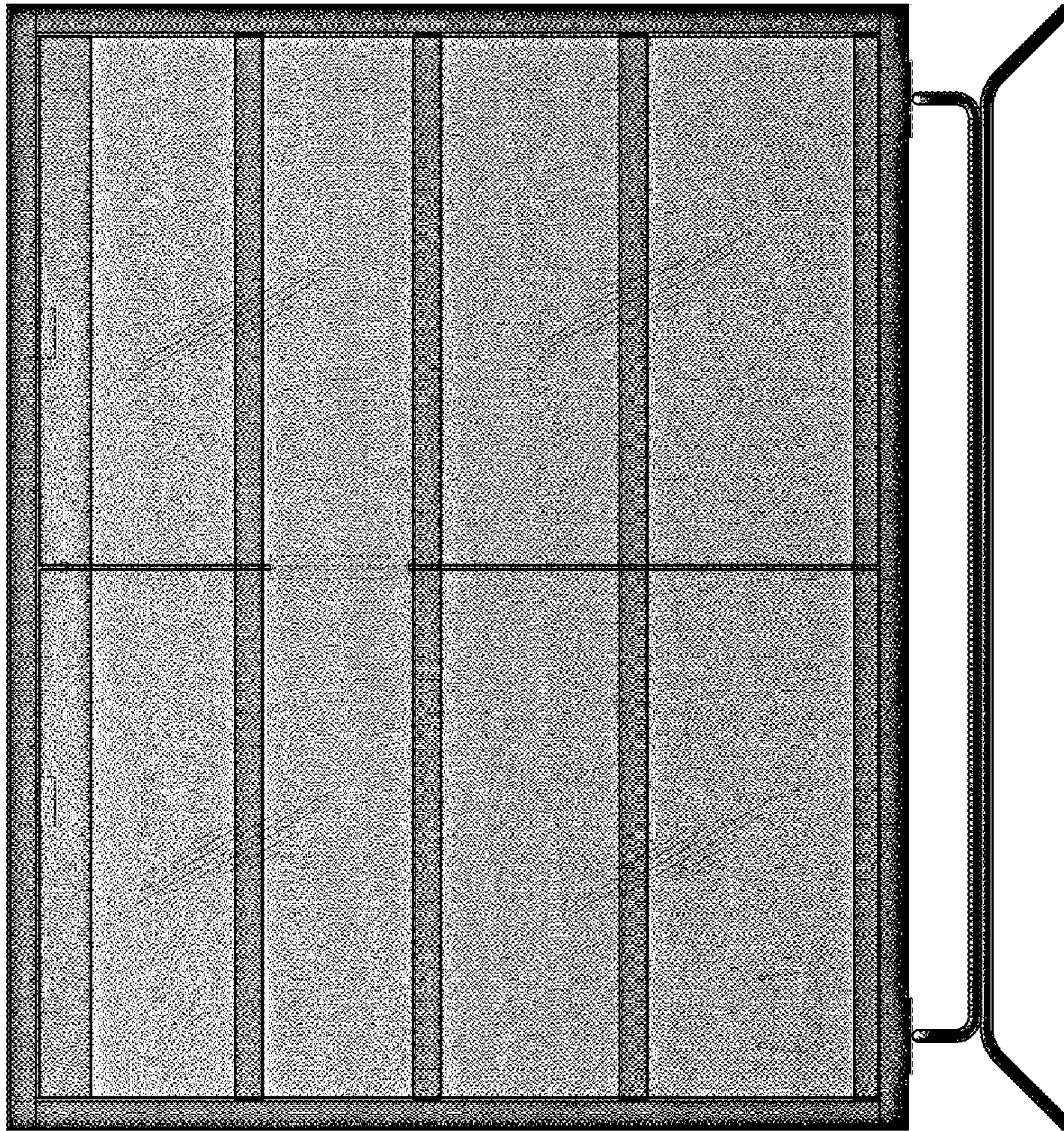

Figure 22

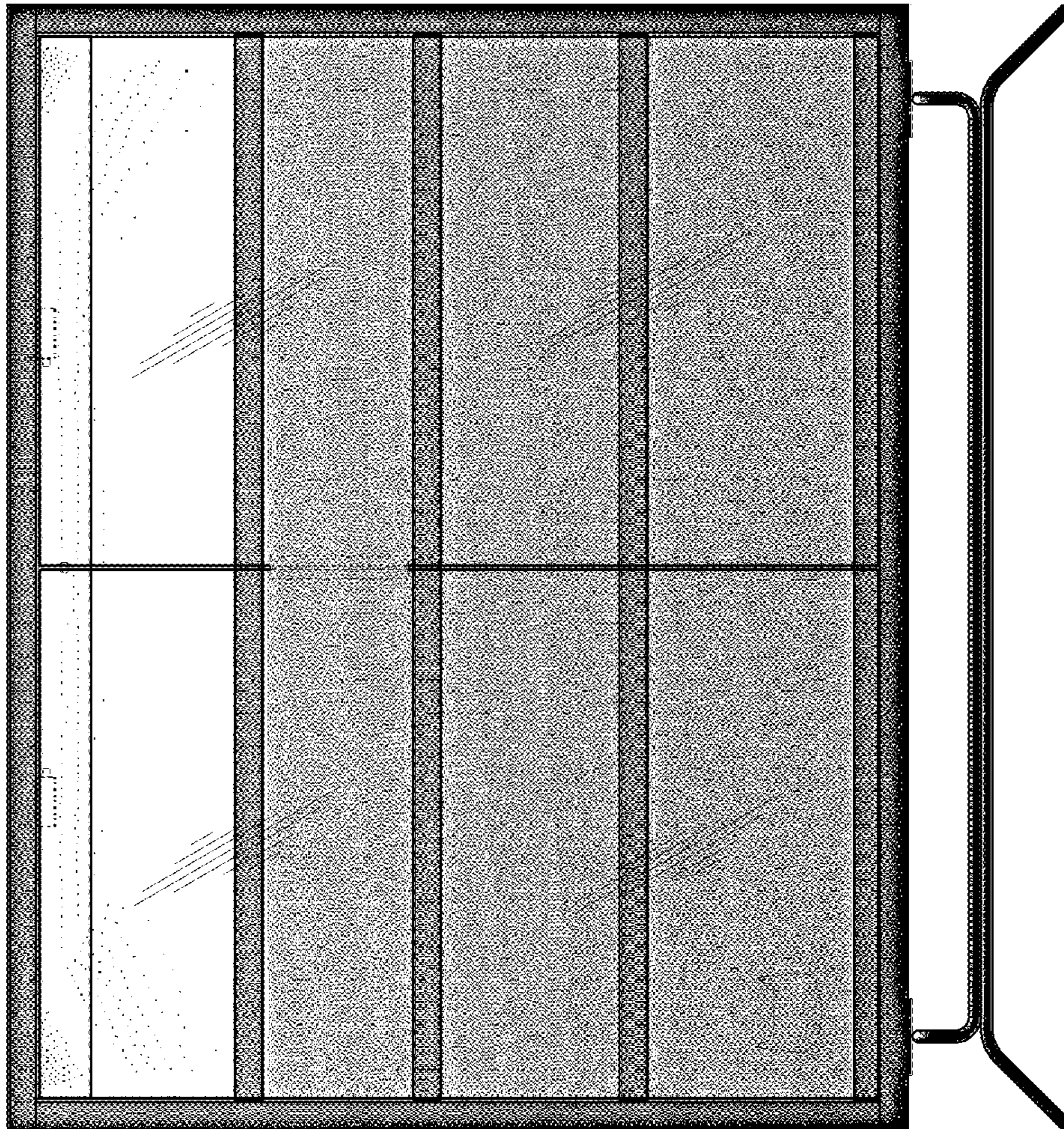

Figure 23

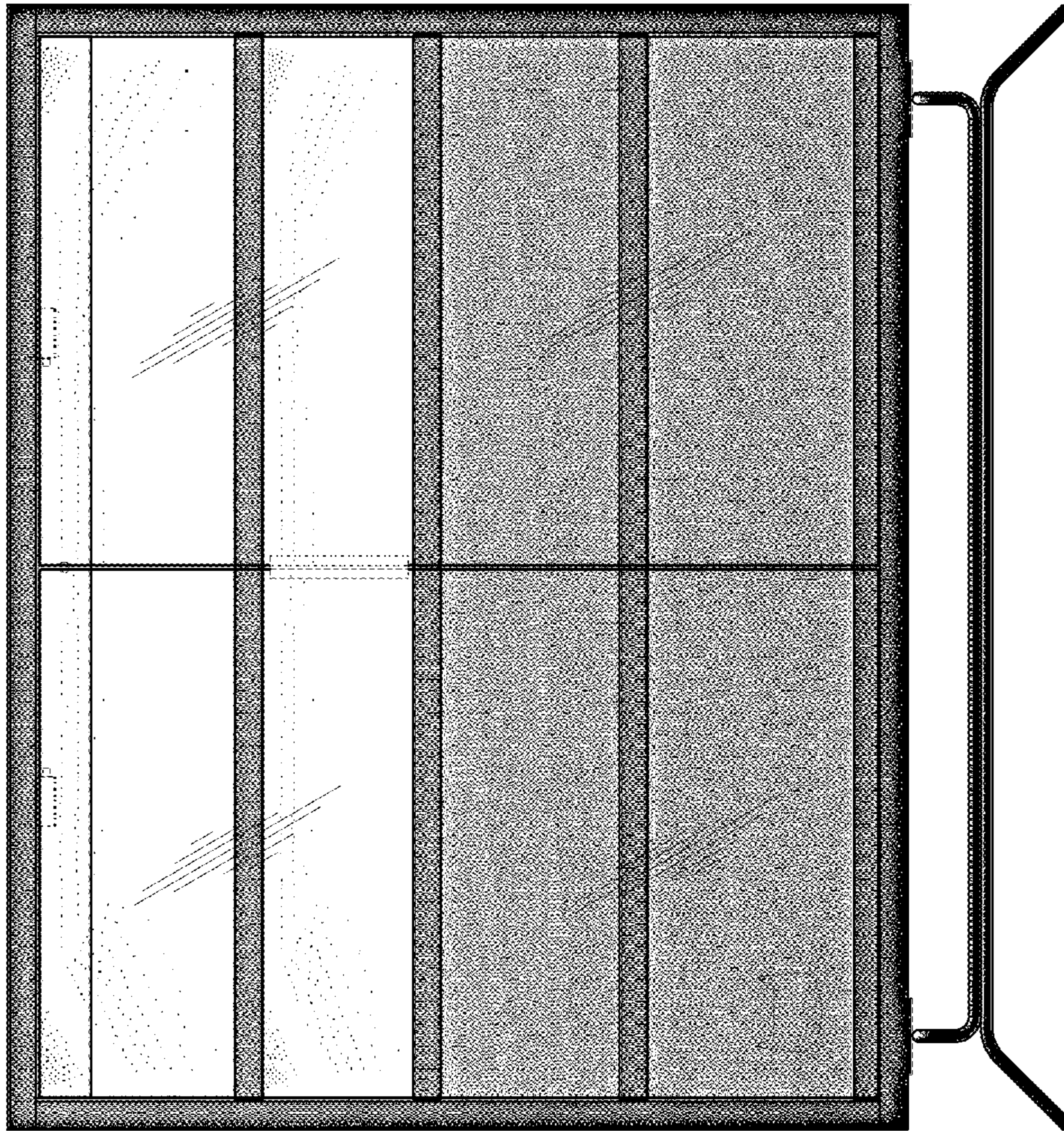

Figure 24

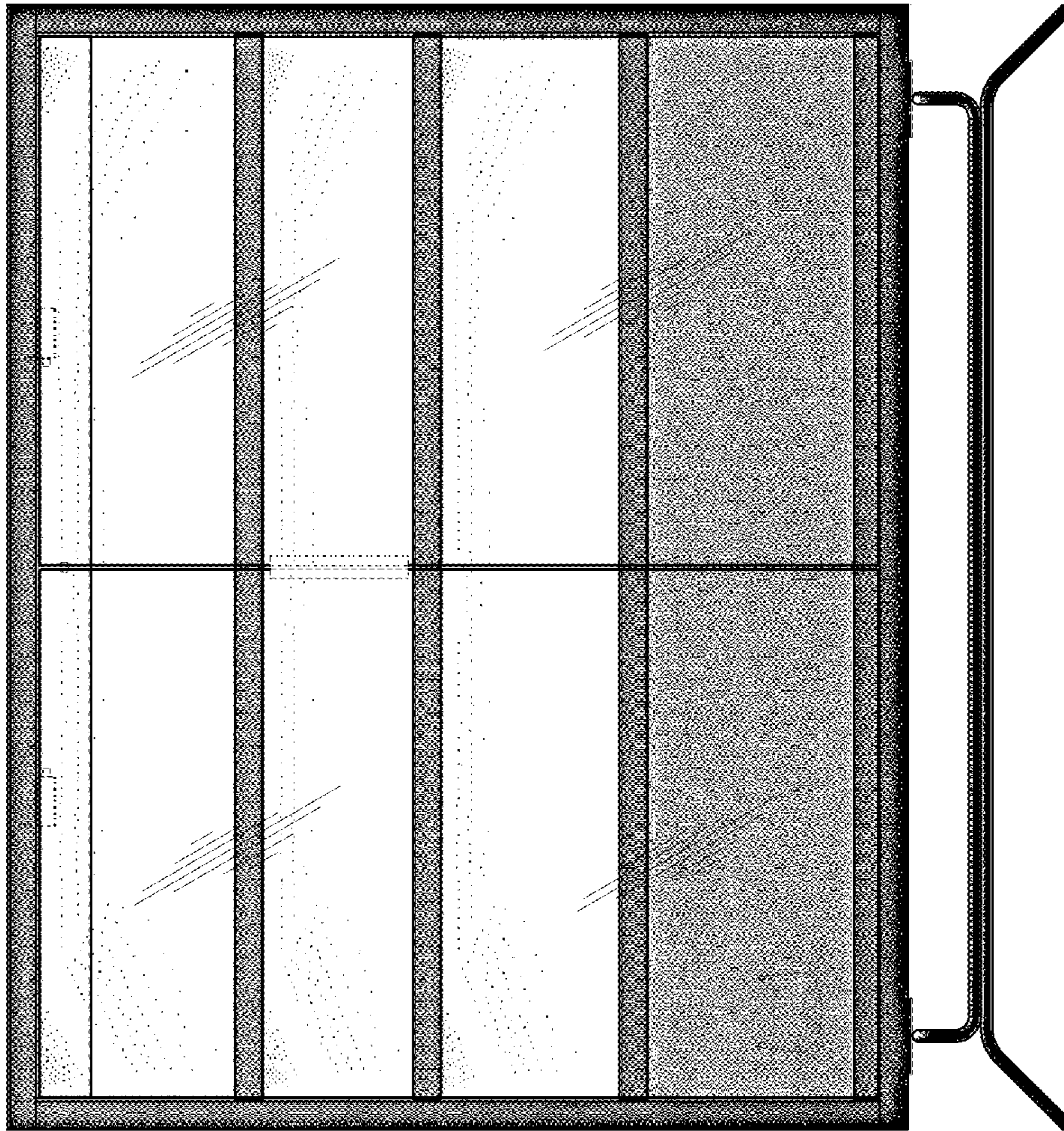

Figure 25



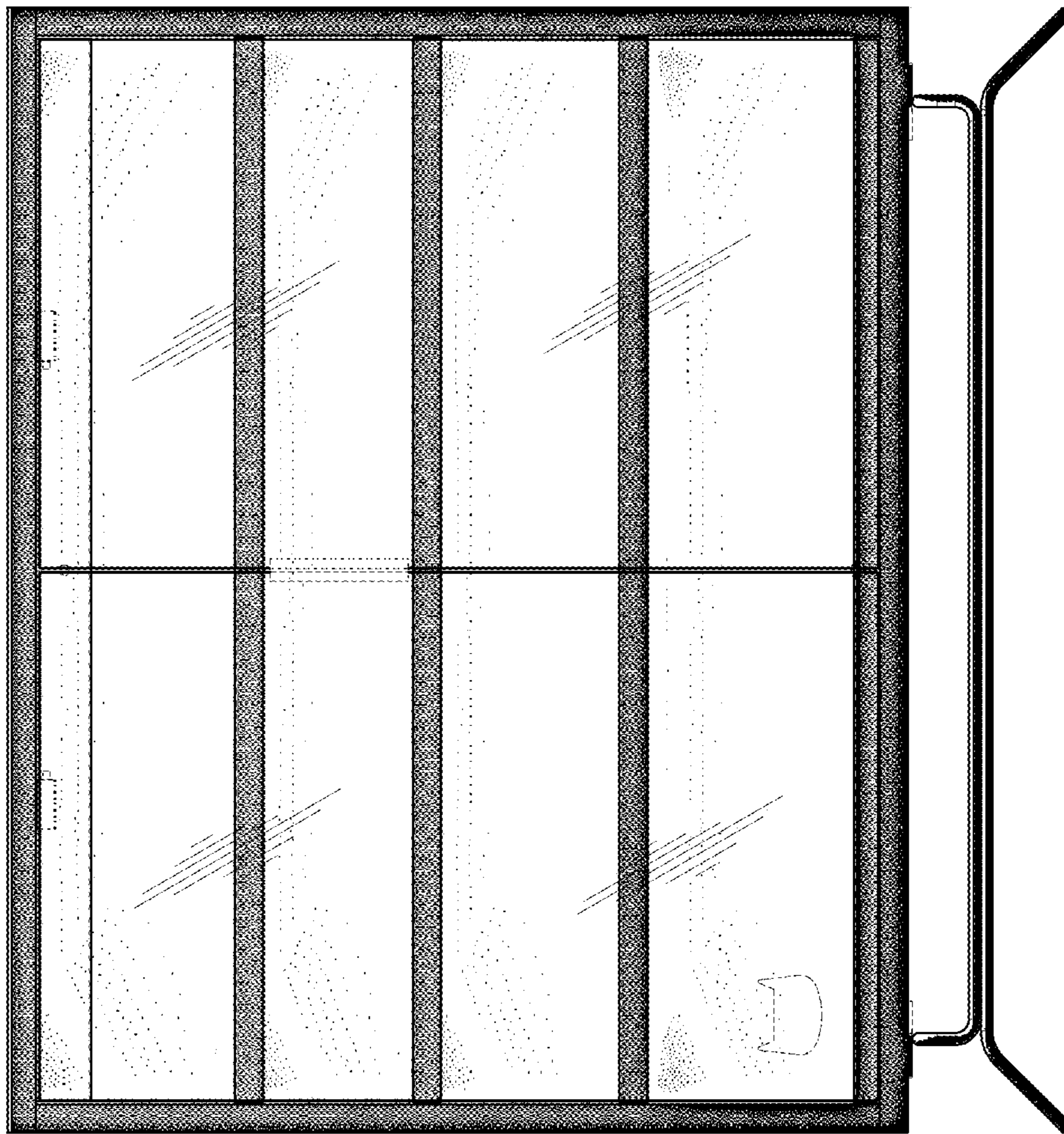

Figure 26

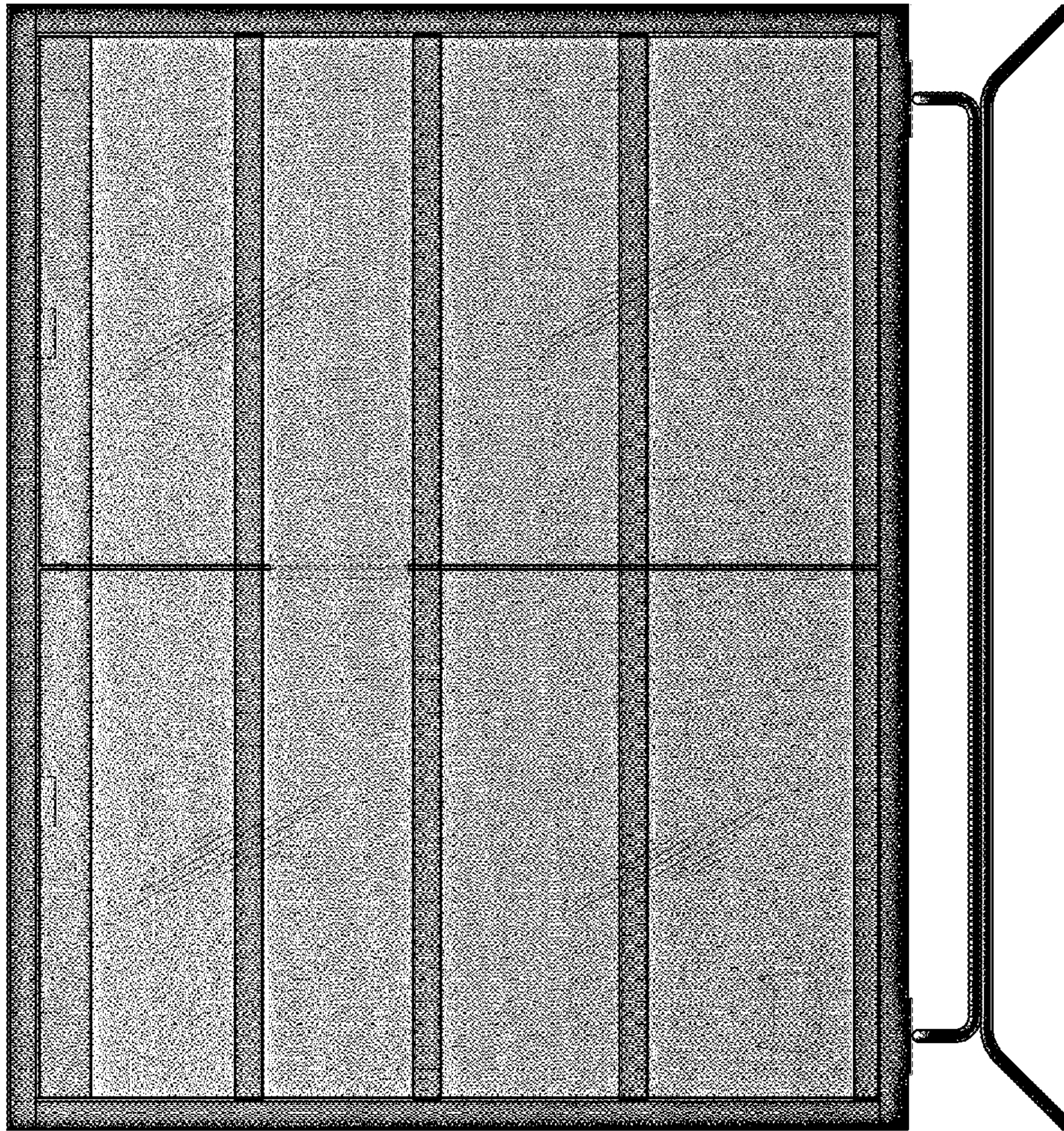

Figure 27

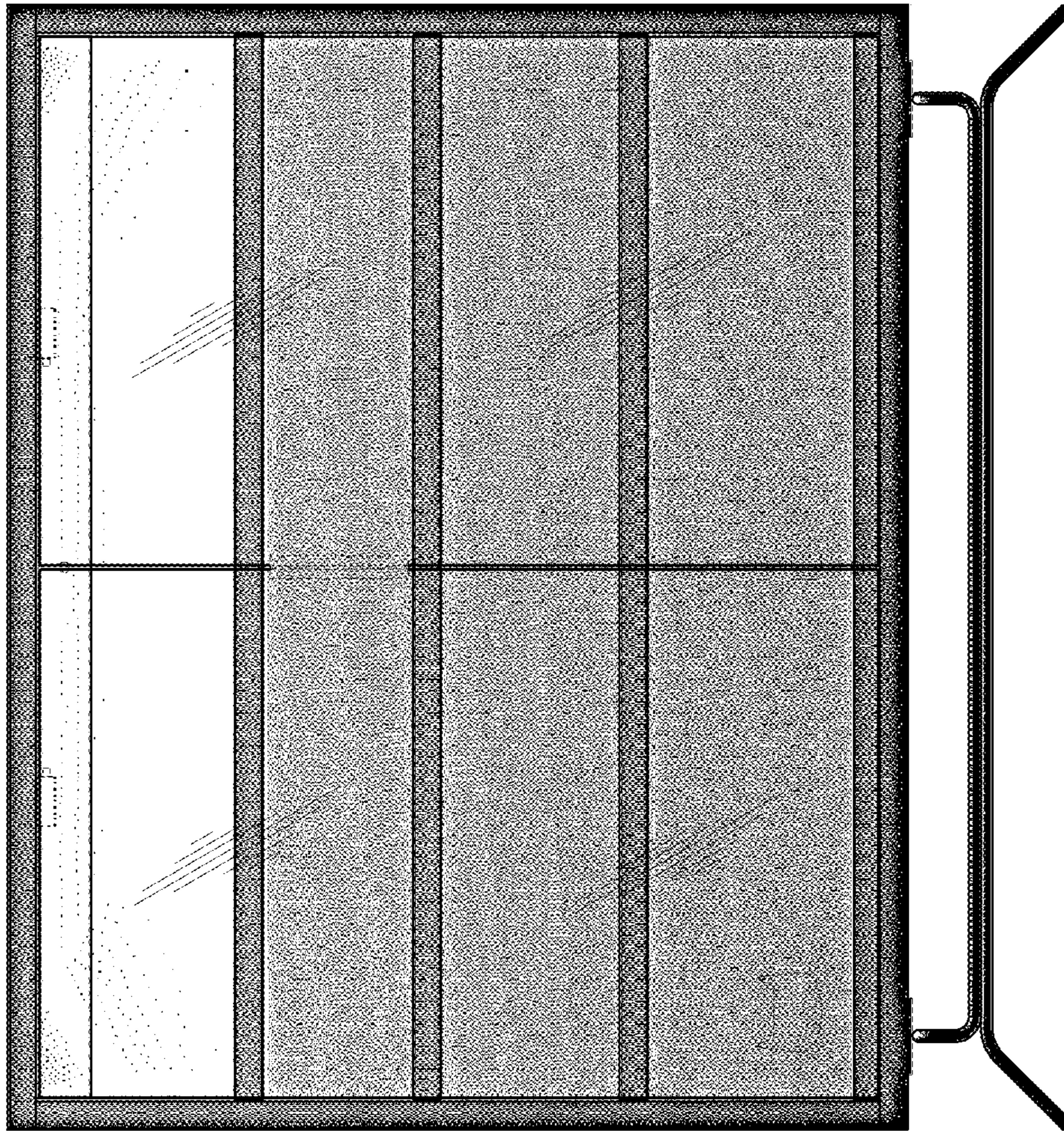

Figure 28

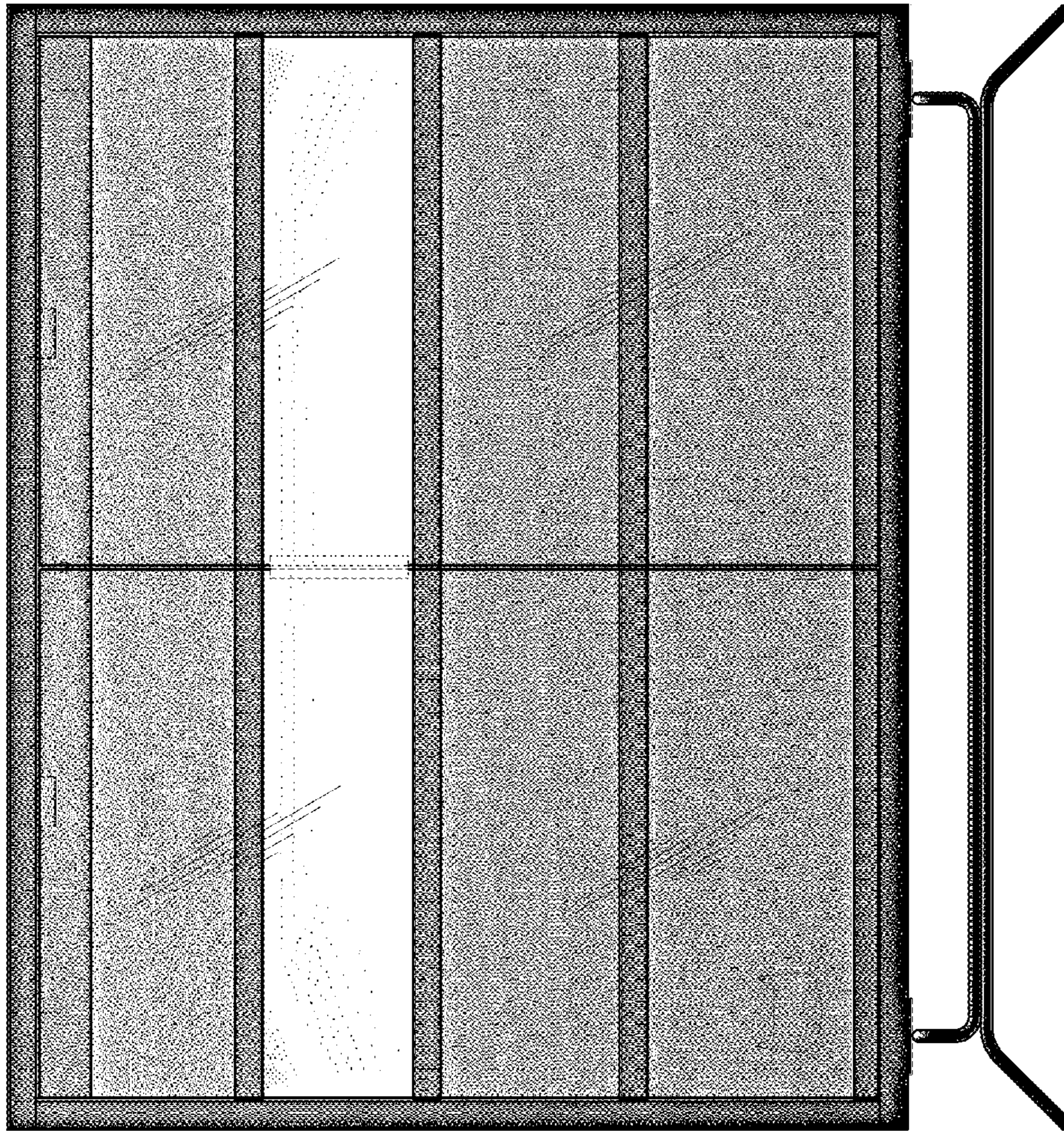

Figure 29

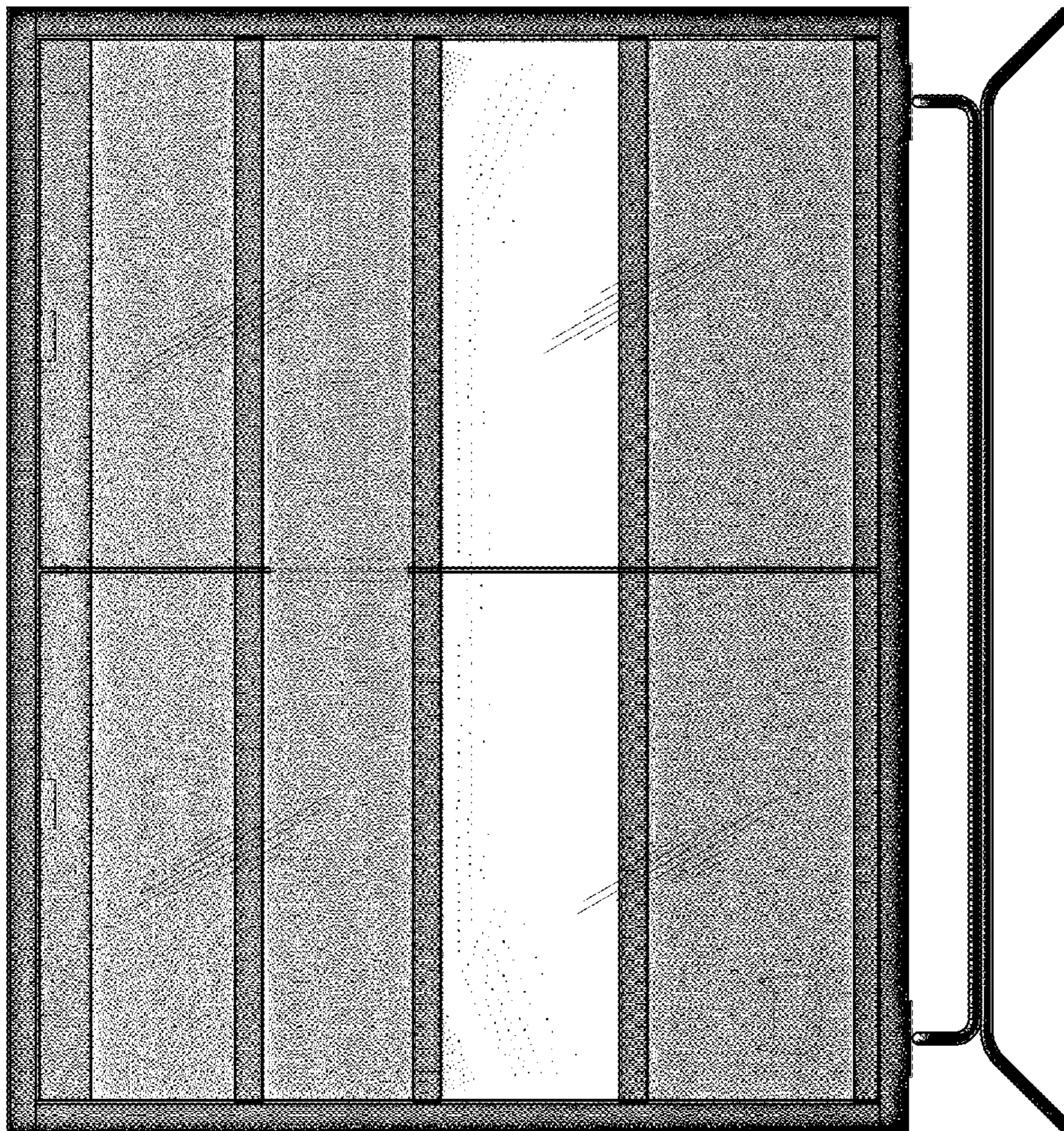

Figure 30

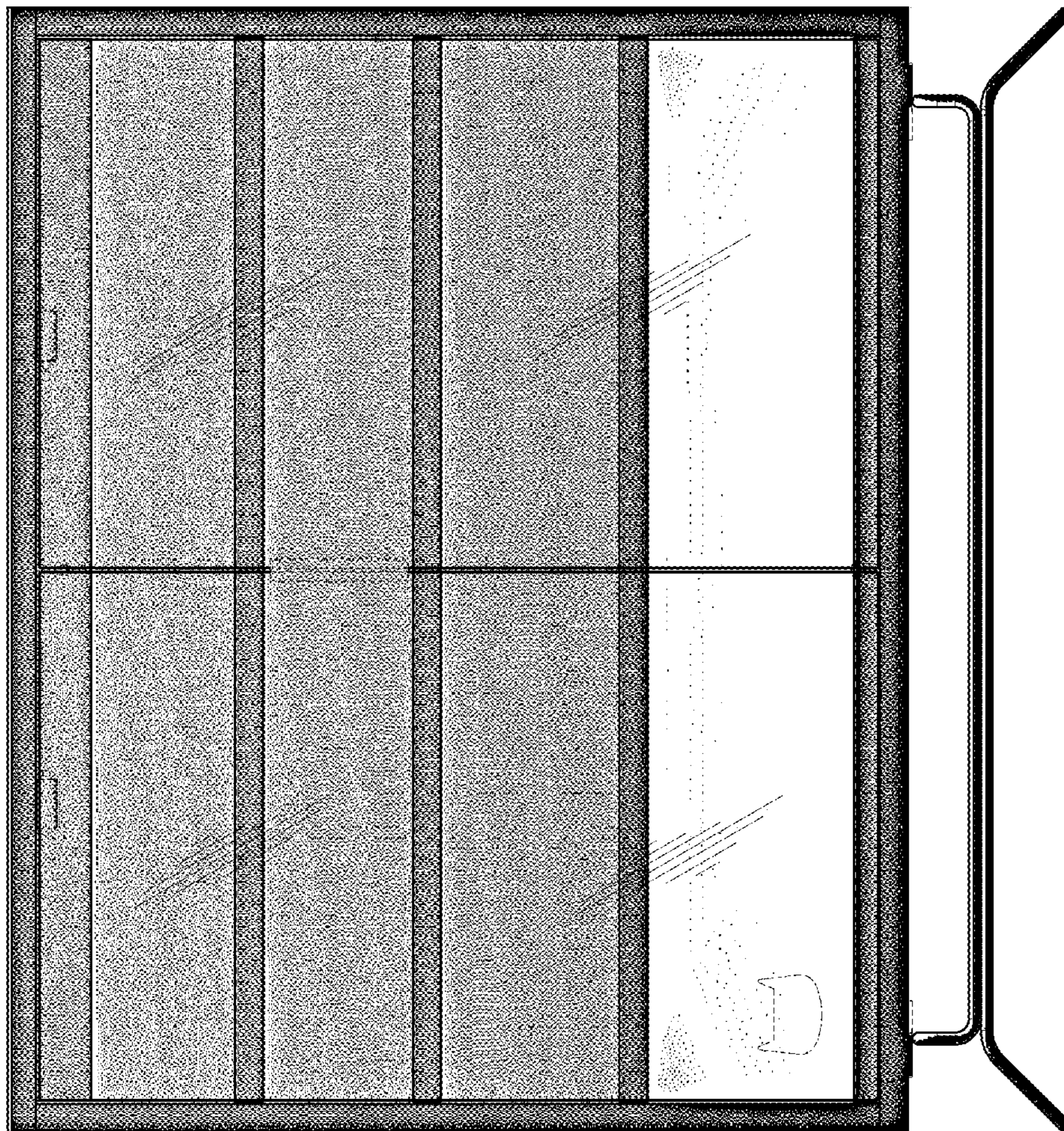

Figure 31

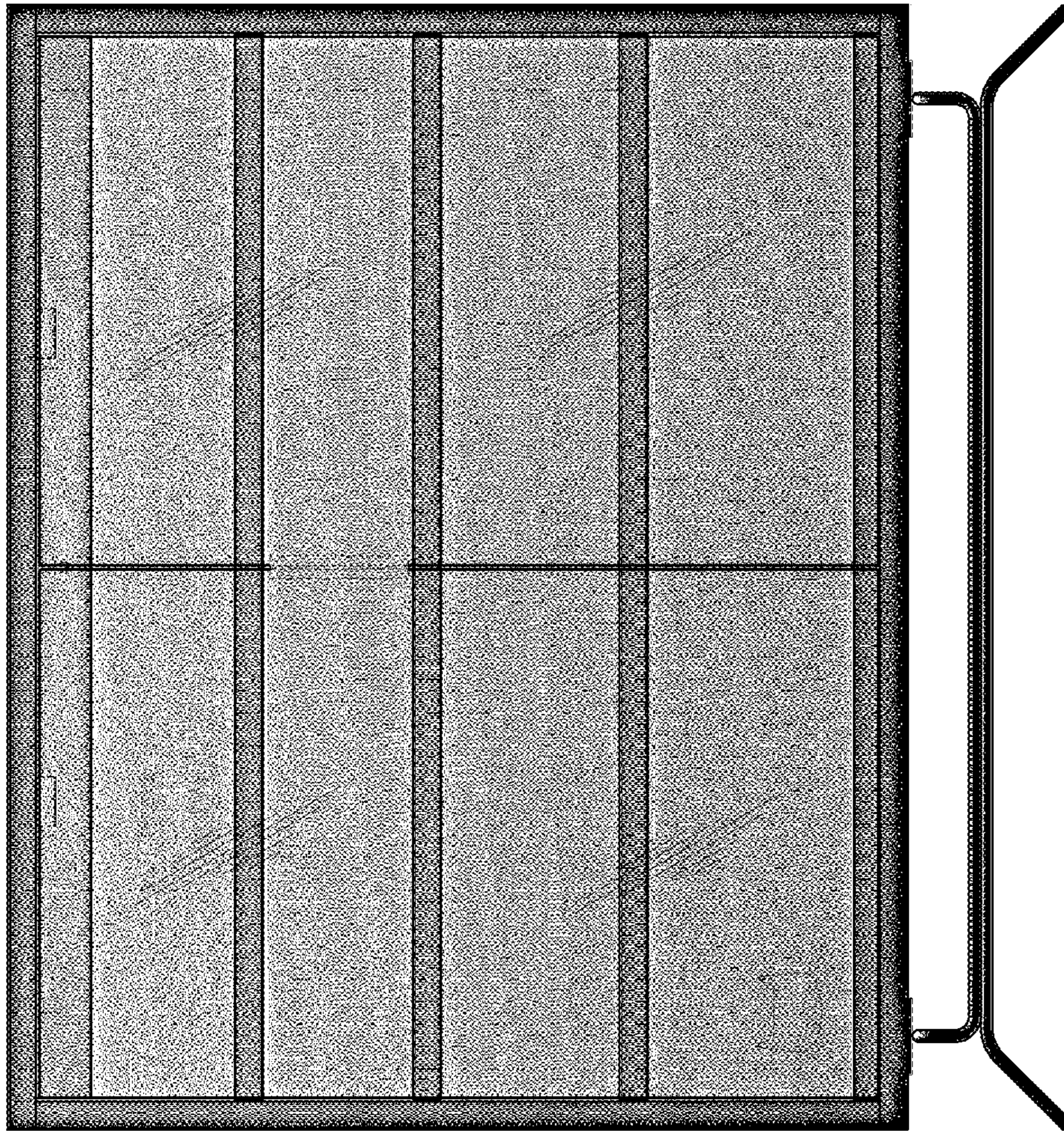

Figure 32

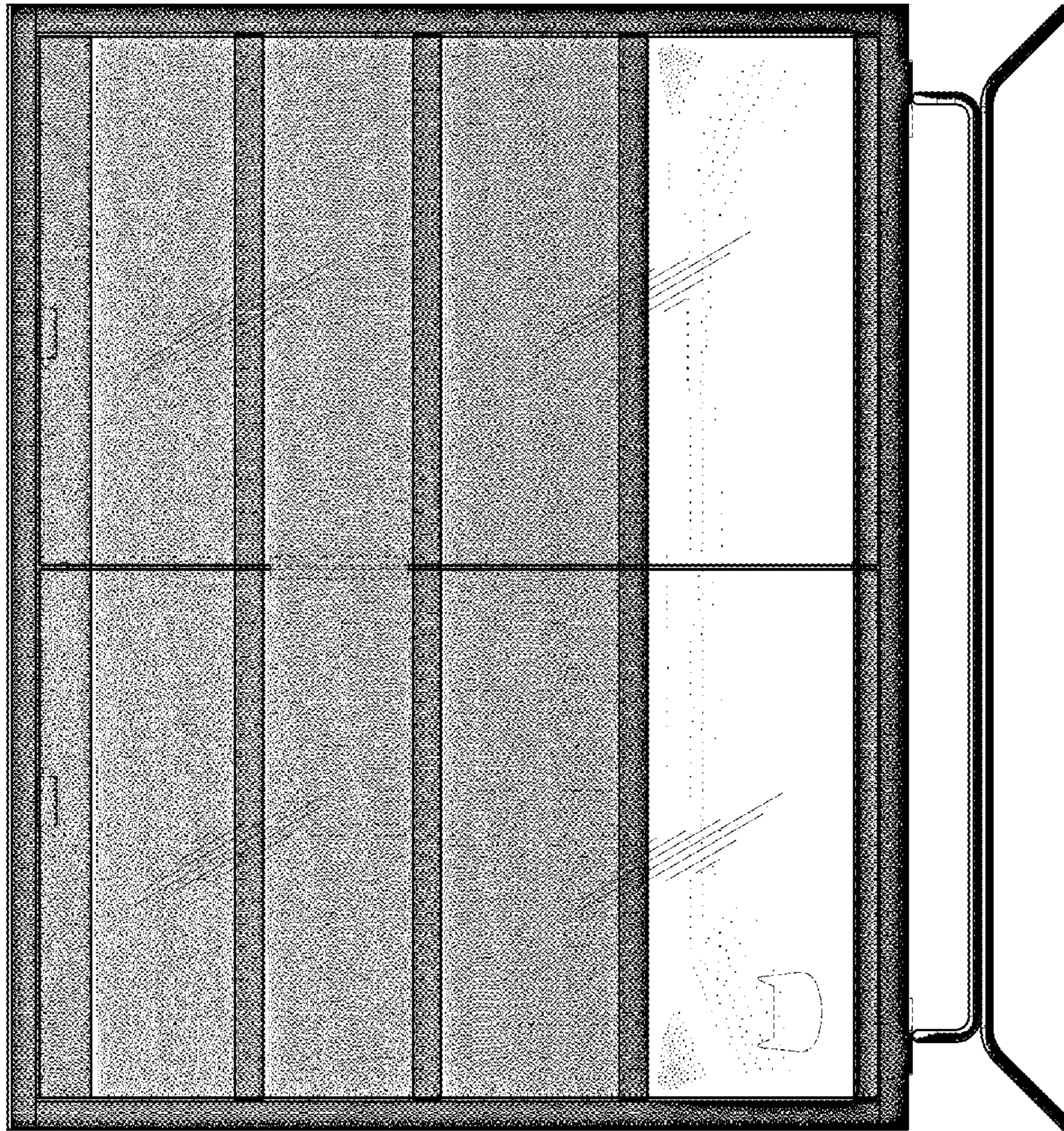

Figure 33



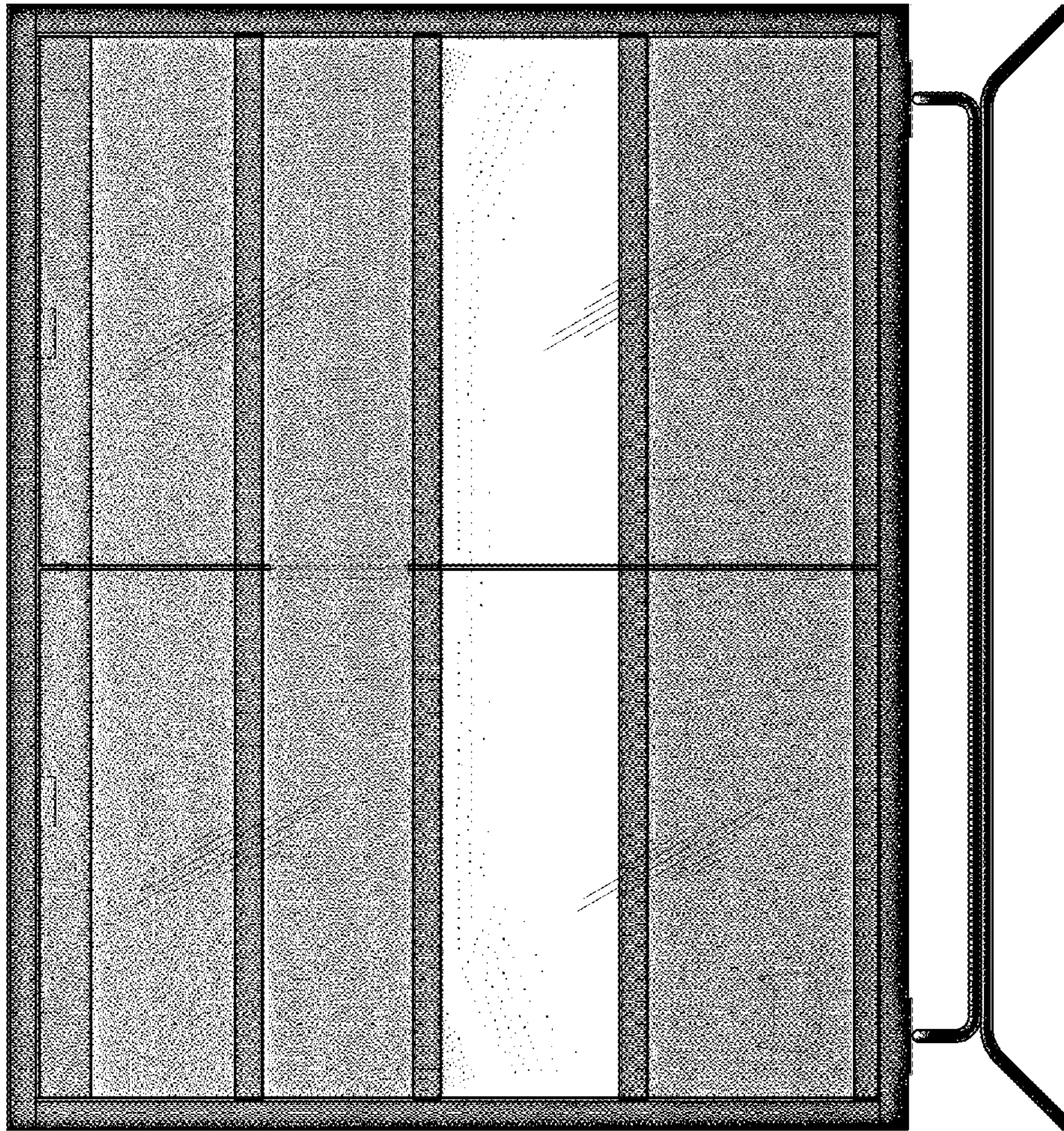

Figure 34

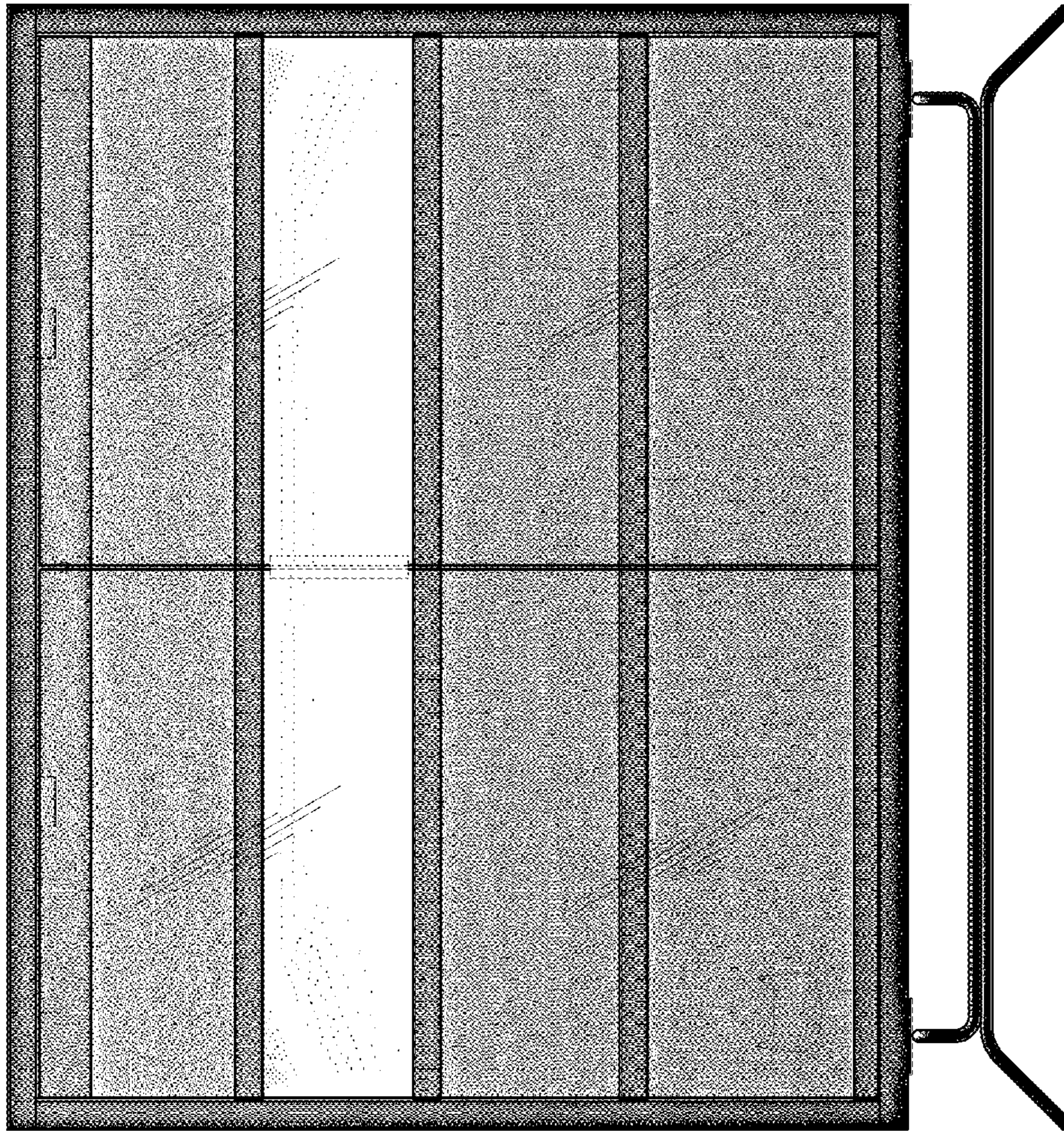

Figure 35

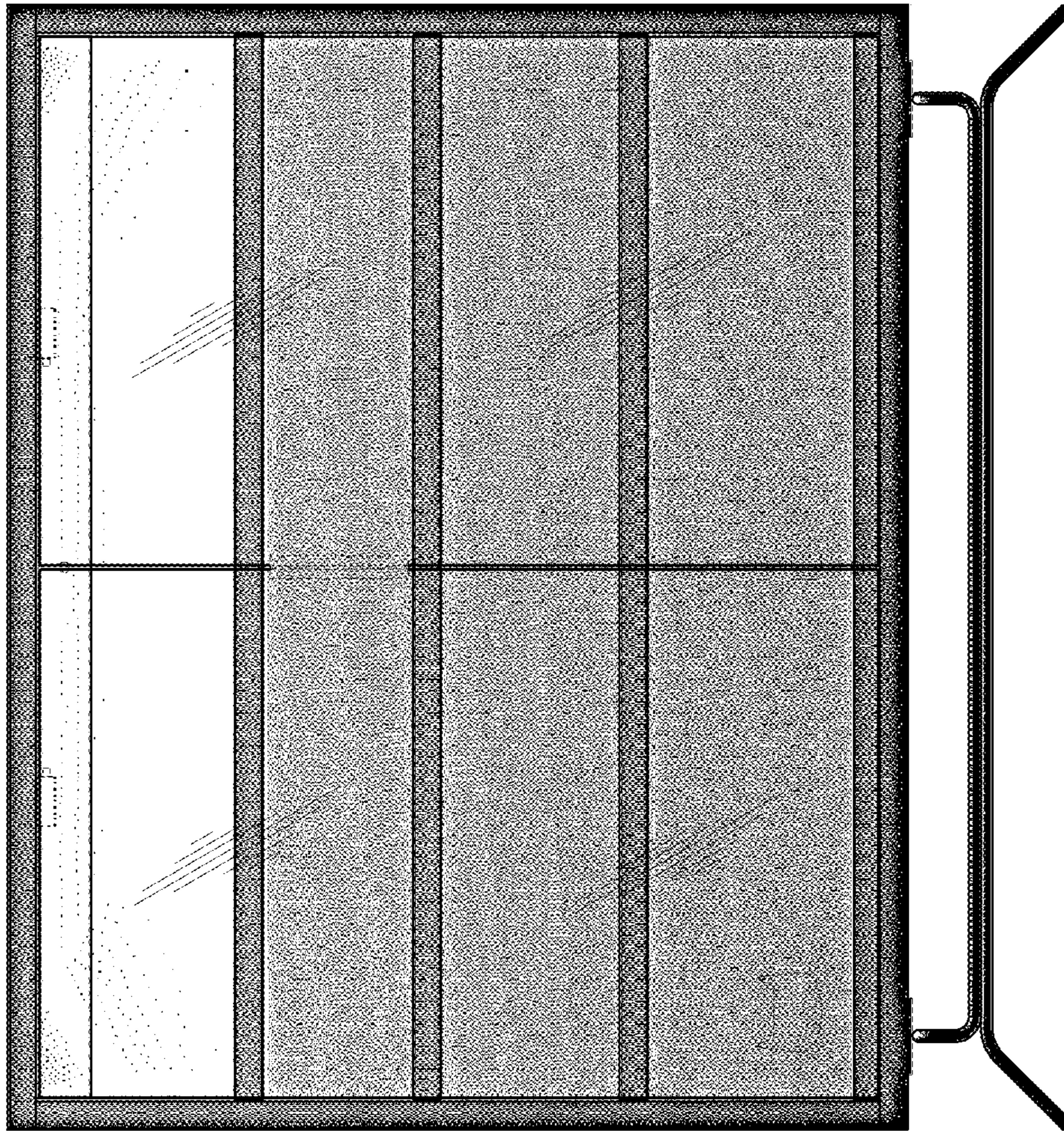

Figure 36

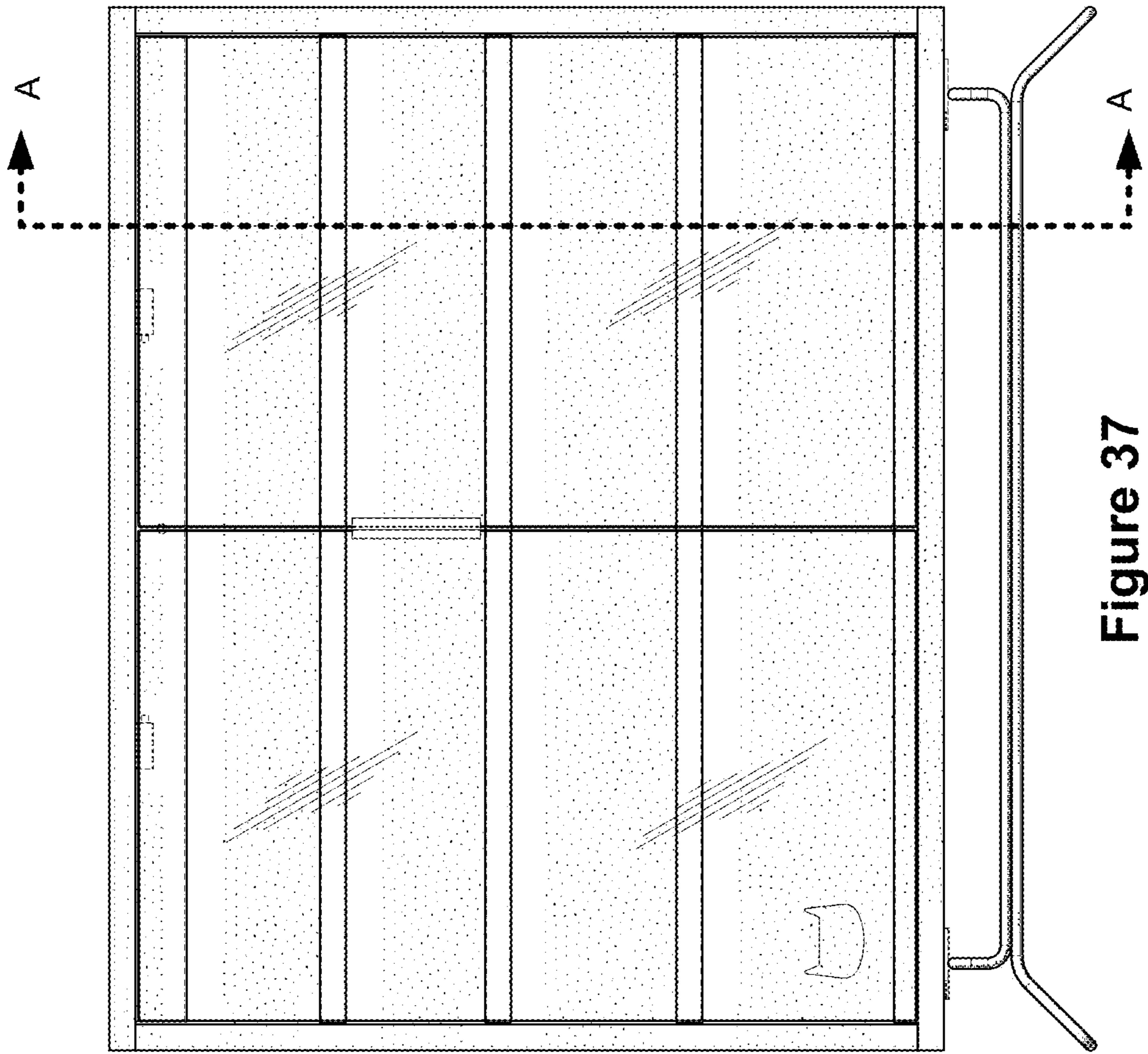

Figure 37

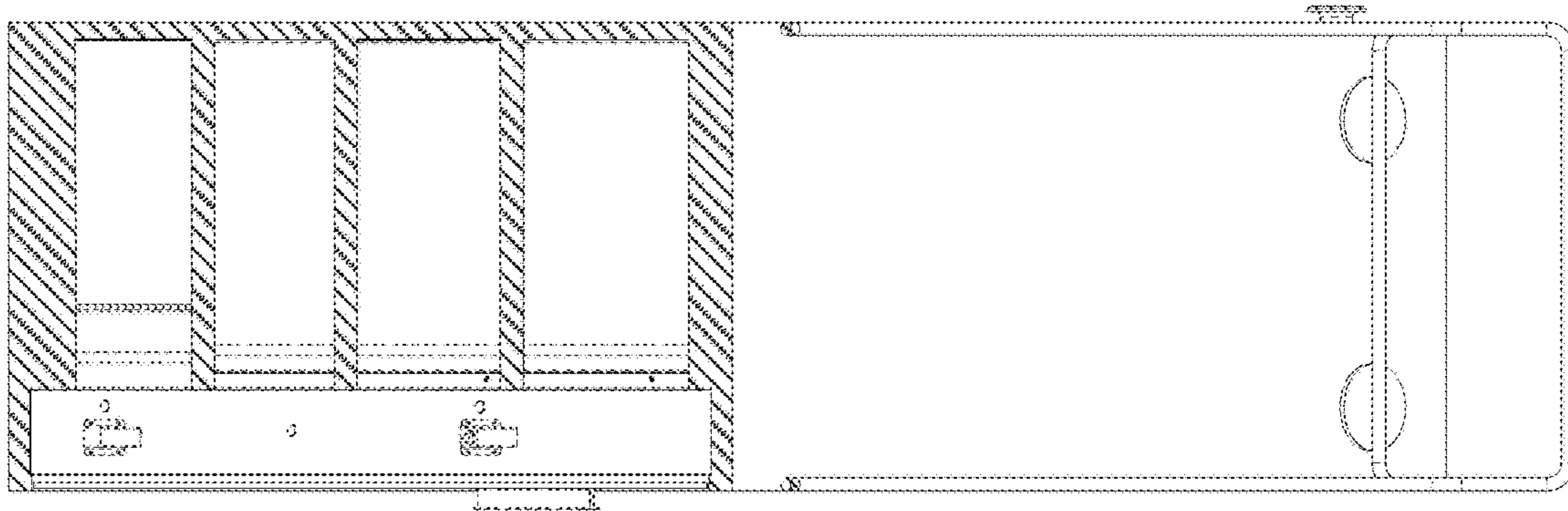

Figure 39

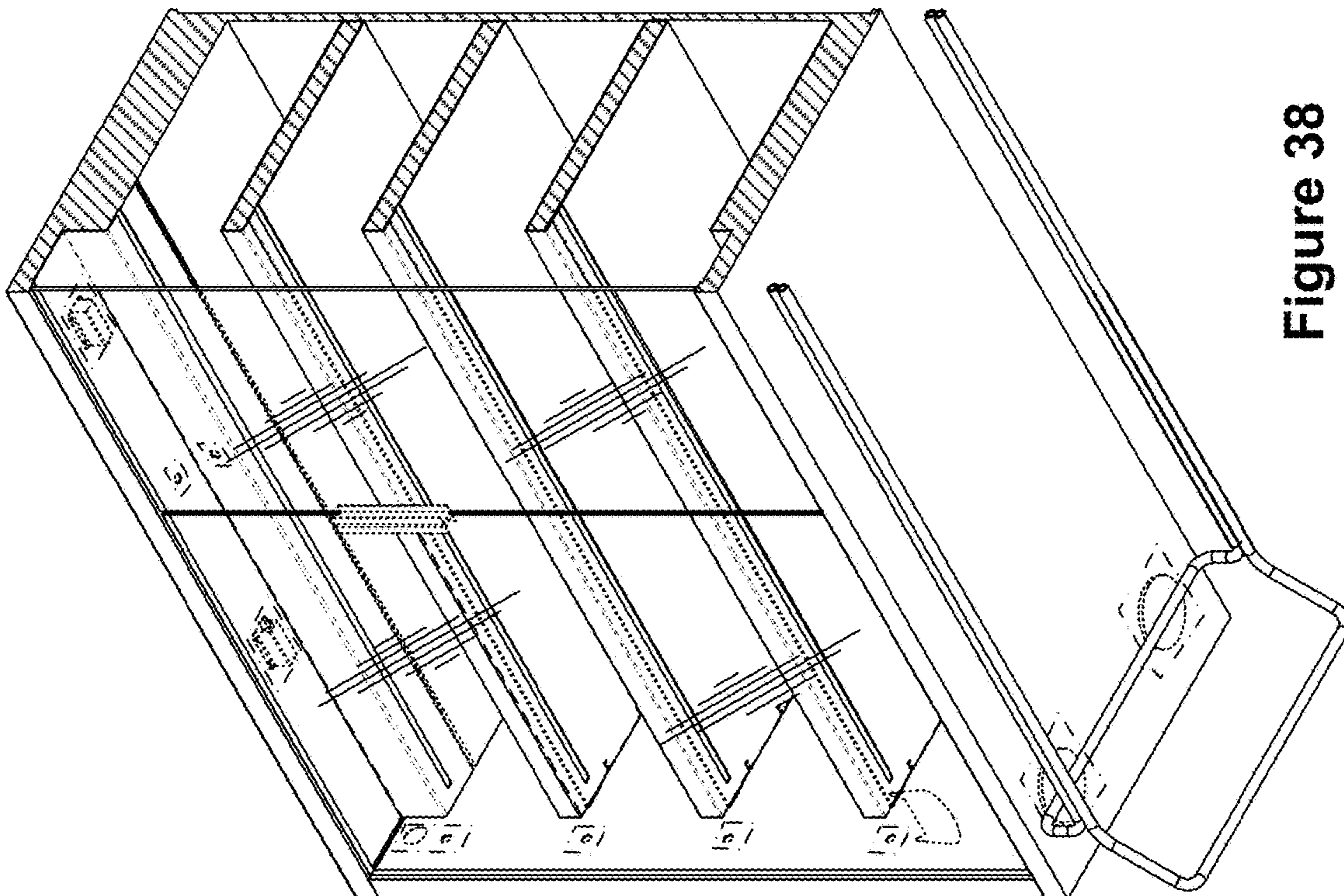

Figure 38