



US00D888105S

(12) **United States Design Patent**  
**Pederson**

(10) **Patent No.:** **US D888,105 S**  
(45) **Date of Patent:** **\*\* Jun. 23, 2020**

- (54) **COMBINATION AGRICULTURAL SUSPENSION AND MOWER UNITS**
- (71) Applicant: **Kverneland Group Kerteminde A/S, Kerteminde (DK)**
- (72) Inventor: **Peder Pederson, Ørbæk (DK)**
- (73) Assignee: **KVERNELAND GROUP KERTEMINDE AS, Kerteminde (DK)**
- (\*\*) Term: **15 Years**
- (21) Appl. No.: **29/674,628**
- (22) Filed: **Dec. 21, 2018**
- (30) **Foreign Application Priority Data**

5,884,460	A *	3/1999	Serravalle	.....	A01D 34/6806
					56/1
6,052,980	A *	4/2000	Friesen	.....	A01D 34/664
					56/16.9
D424,071	S *	5/2000	Bickford	.....	D15/17
D435,564	S *	12/2000	Klasson	.....	D15/17
D445,432	S *	7/2001	Bickford	.....	D15/27
6,681,553	B2 *	1/2004	Ferree	.....	A01D 34/667
					56/13.6
D501,215	S *	1/2005	Steele	.....	D15/17
D547,332	S *	7/2007	Degelman	.....	D15/17
D590,844	S *	4/2009	Eavenson, Sr.	.....	D15/14
7,784,255	B2 *	8/2010	Moore, Jr.	.....	A01D 75/306
					56/320.1
D660,875	S *	5/2012	Mabey	.....	D15/17
D670,315	S *	11/2012	Fraley	.....	D15/14
D719,981	S *	12/2014	Miller	.....	D15/17
D800,179	S *	10/2017	Nielsen	.....	D15/14
D800,180	S *	10/2017	Nielsen	.....	D15/14

(Continued)

- Jun. 22, 2018 (EM) ..... 005321908
- (51) **LOC (12) Cl.** ..... **15-03**
- (52) **U.S. Cl.**  
USPC ..... **D15/14; D15/17**
- (58) **Field of Classification Search**  
USPC ..... D15/17, 10, 14, 16, 11, 13, 19, 21, 27,  
D15/28; 56/14.9, 14.5, 153, 192, 6, 15.5,  
56/189  
CPC .... A01D 34/664; A01D 34/66; A01D 34/667;  
A01D 34/81; A01D 34/661; A01D  
34/668; A01D 61/004  
See application file for complete search history.

*Primary Examiner* — Mark A Goodwin  
(74) *Attorney, Agent, or Firm* — Knobbe, Martens, Olson & Bear, LLP

(57) **CLAIM**

The ornamental design for a combination agricultural suspension and mower units, as shown and described.

**DESCRIPTION**

FIG. 1 is an upper, left, rear perspective view of a combination agricultural suspension and mower units, showing my new design;  
FIG. 2 is an upper, right, front perspective view thereof;  
FIG. 3 is a front elevational view thereof;  
FIG. 4 is a rear elevational view thereof;  
FIG. 5 is a left side elevational view thereof;  
FIG. 6 is a right side elevational view thereof; and,  
FIG. 7 is a top plan view thereof.  
The broken lines in the figures depict environmental features that form no part of the claimed design.

- (56) **References Cited**  
U.S. PATENT DOCUMENTS  
D271,398 S \* 11/1983 McCanse ..... D15/27  
5,491,964 A \* 2/1996 Butler ..... A01D 42/005  
56/320.2  
D394,662 S \* 5/1998 Grow ..... D15/17  
5,822,961 A \* 10/1998 Busboom ..... A01D 34/6806  
56/11.4

**1 Claim, 7 Drawing Sheets**

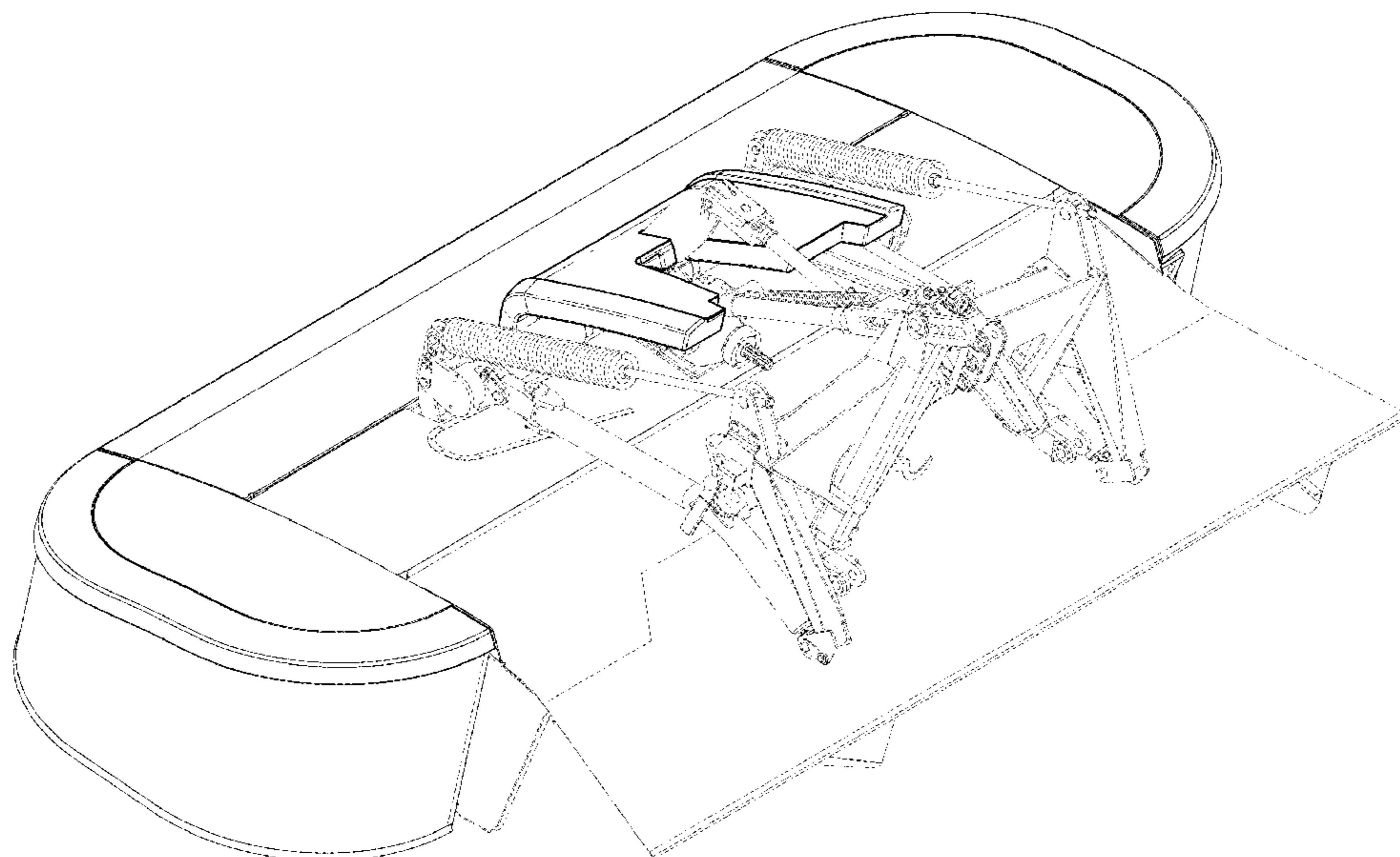

(56)

**References Cited**

U.S. PATENT DOCUMENTS

2009/0071116 A1\* 3/2009 Barnett ..... A01D 34/668  
56/153  
2015/0230405 A1\* 8/2015 Rosenbalm ..... A01D 57/00  
56/153  
2016/0157425 A1\* 6/2016 Jespersen ..... A01D 34/661  
56/6

\* cited by examiner

FIG. 1

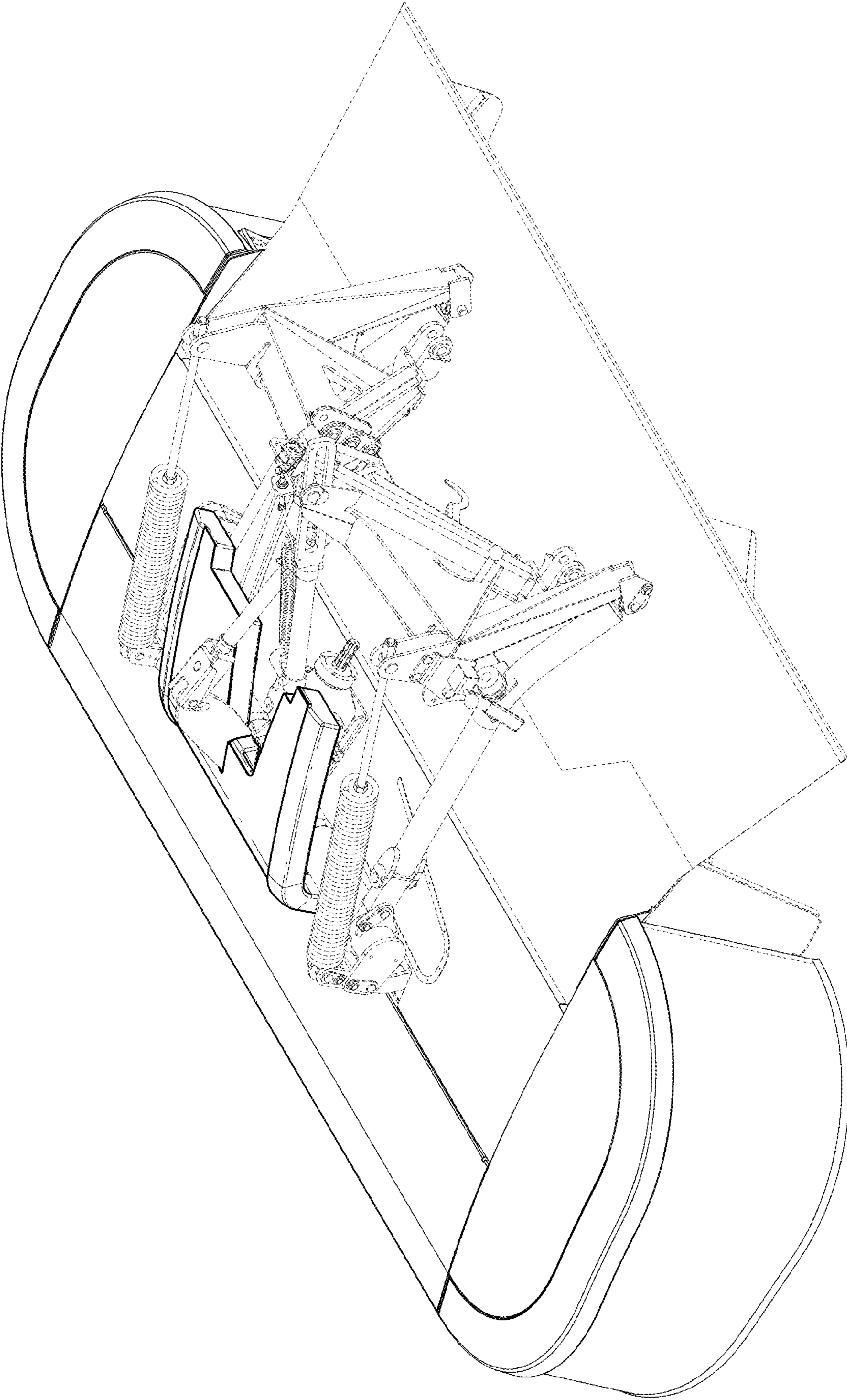
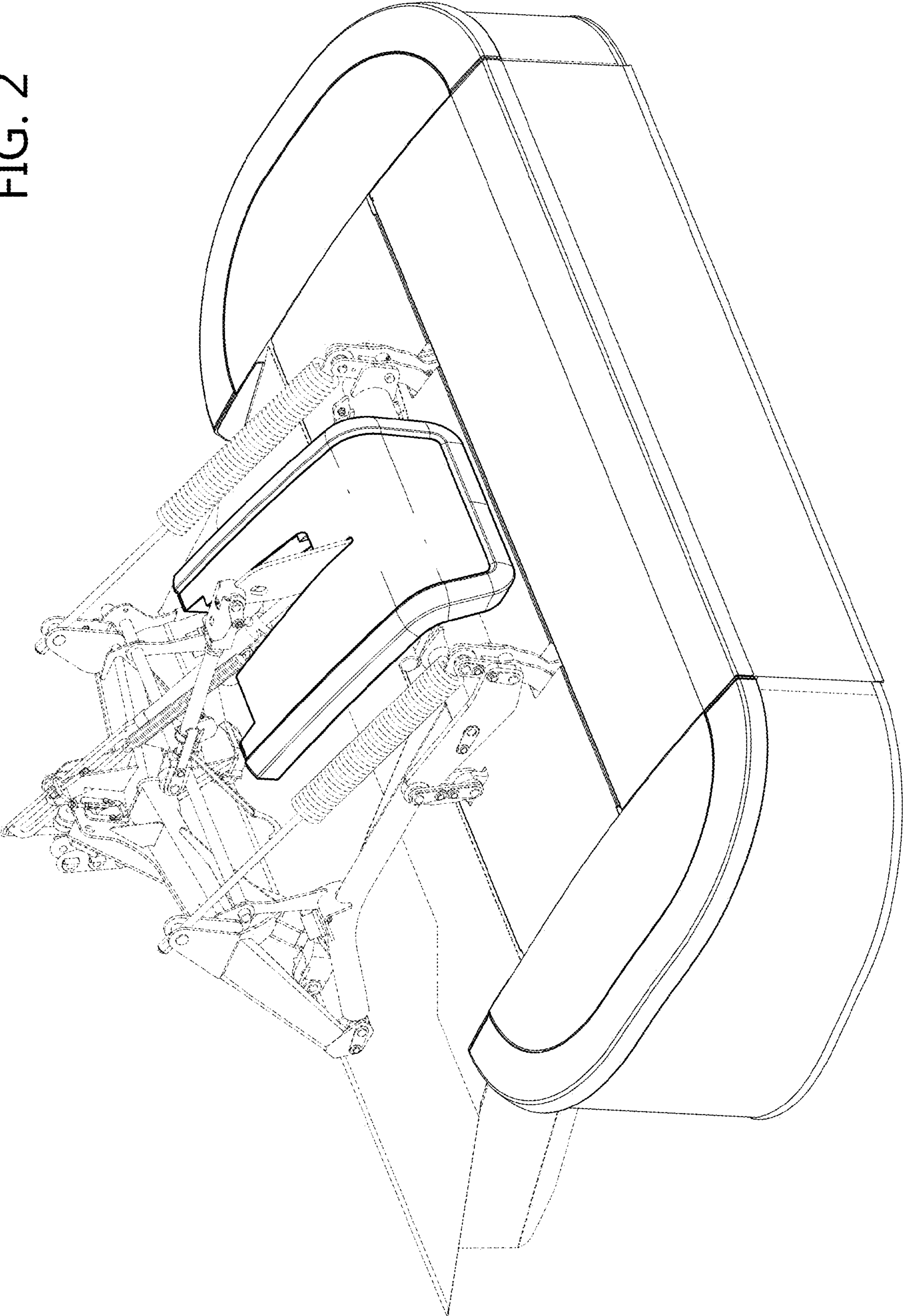

FIG. 2



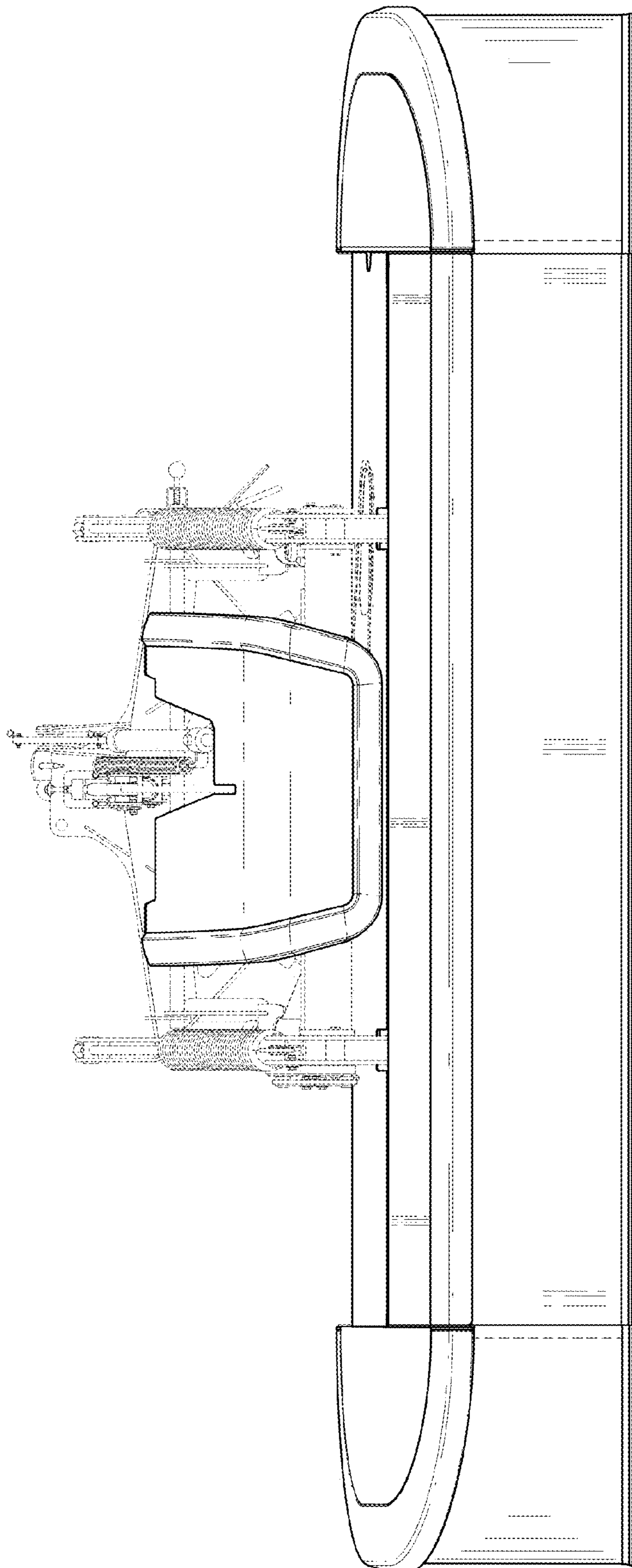

FIG. 3

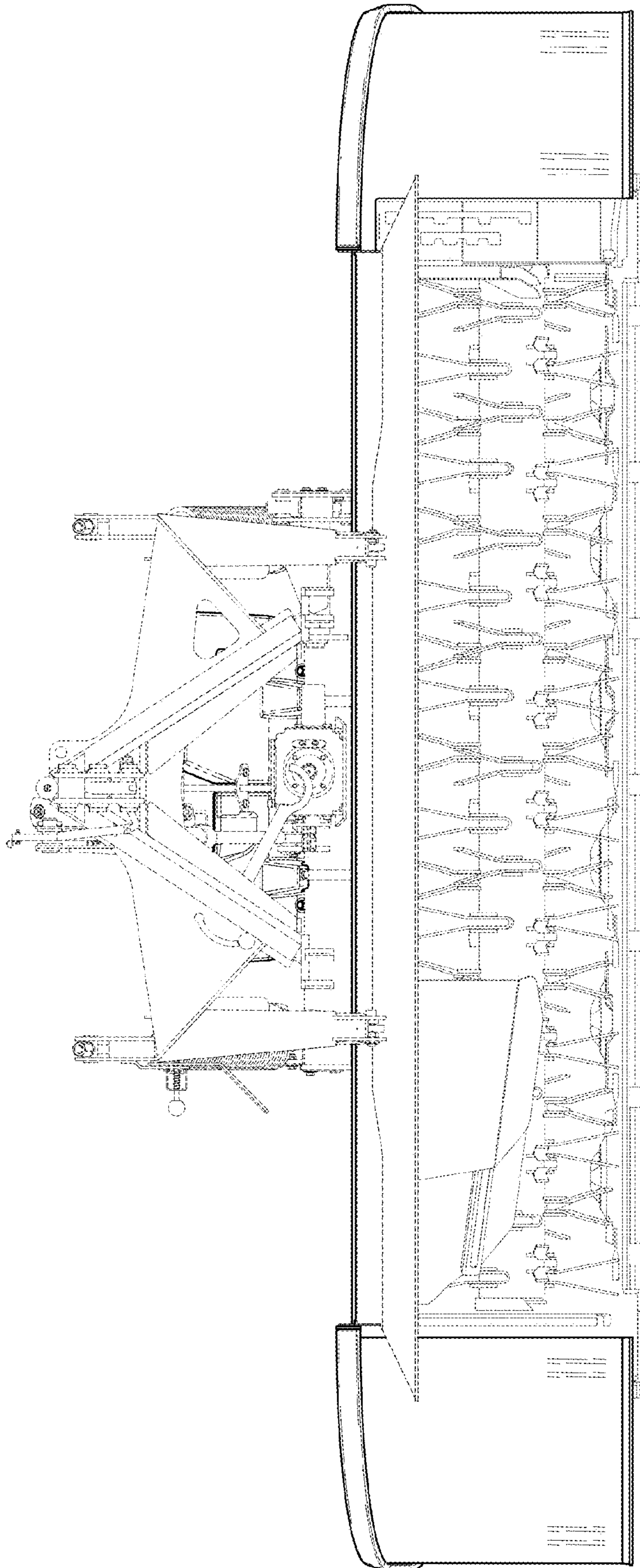

FIG. 4

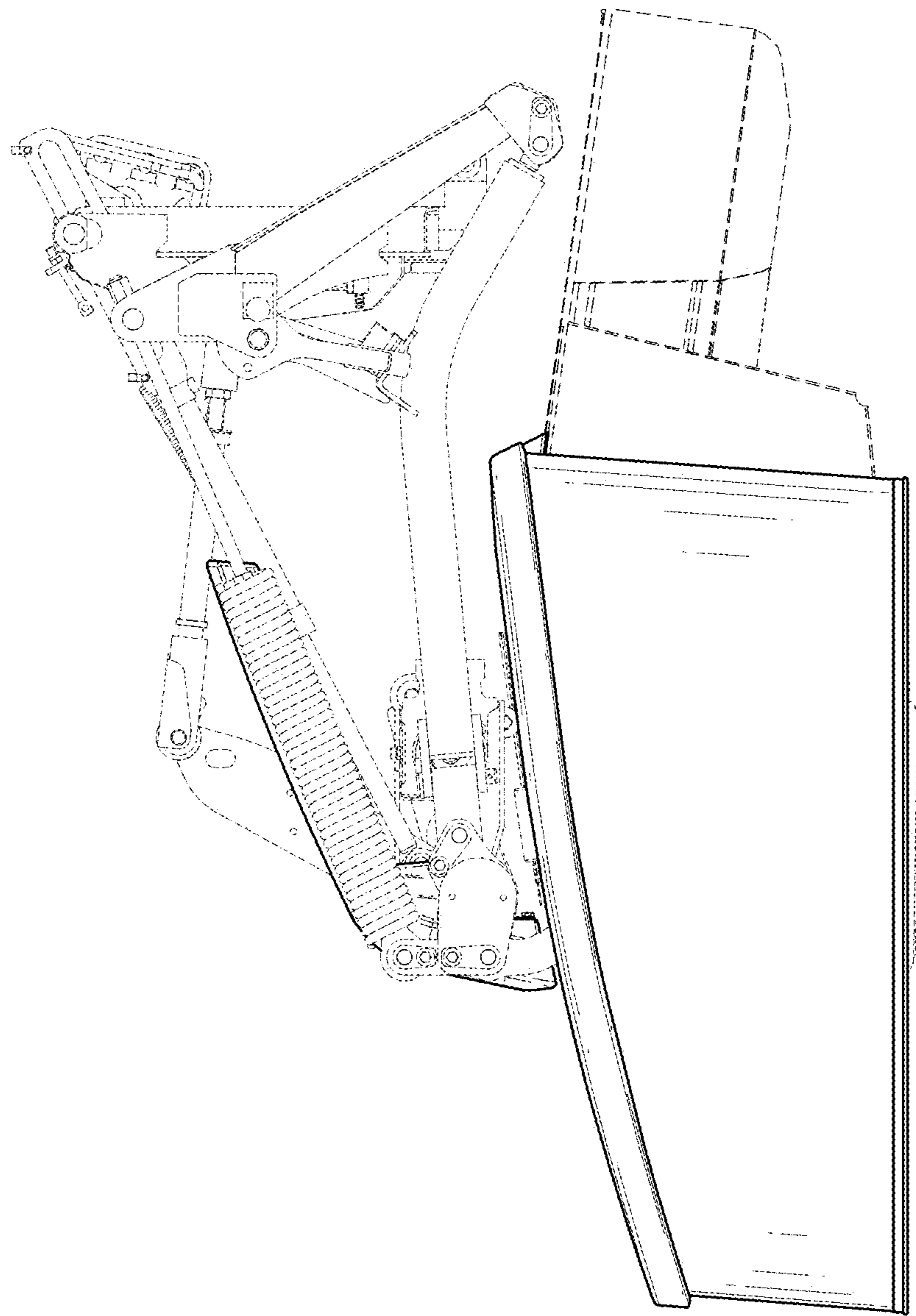

FIG. 5

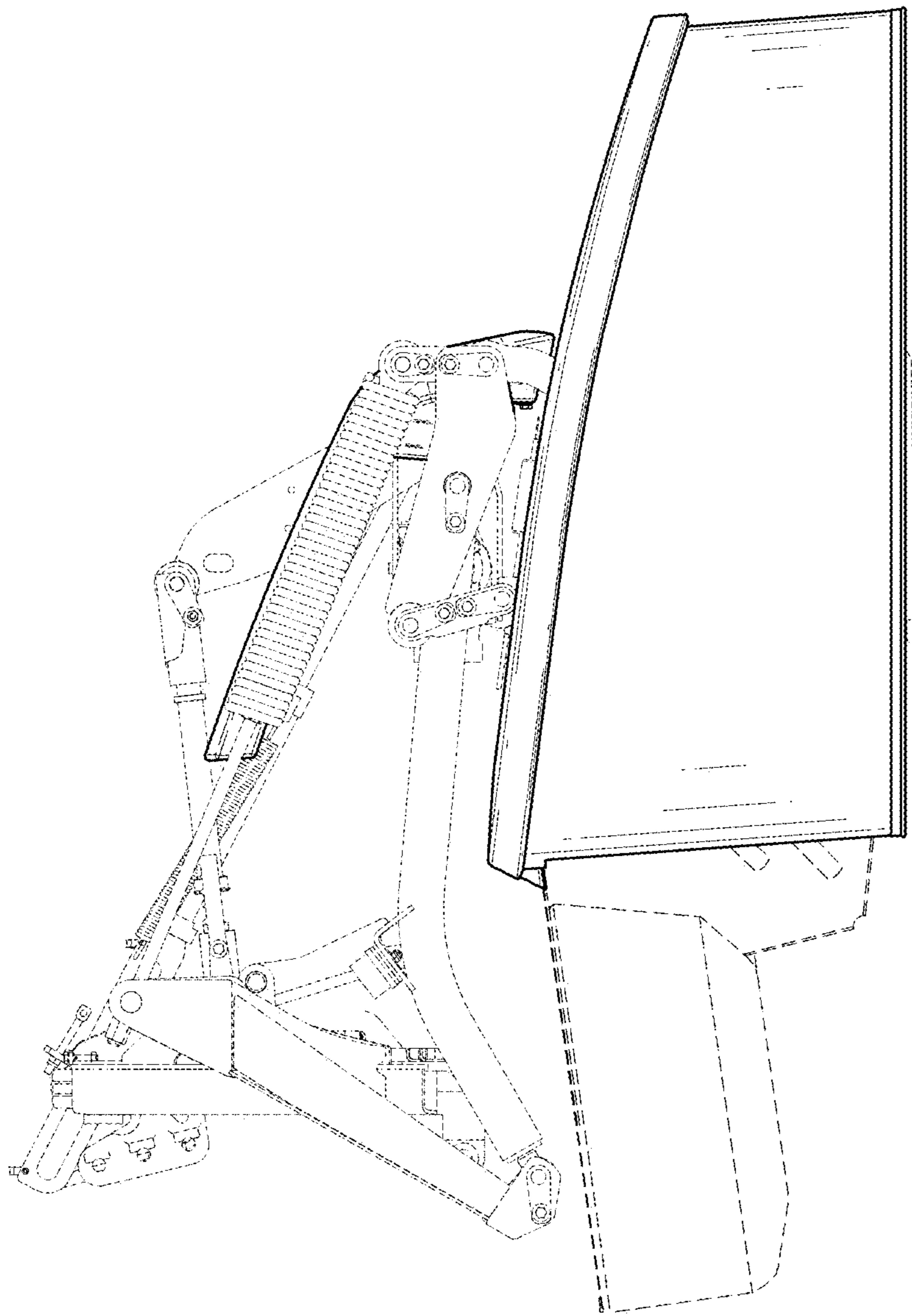

FIG. 6



FIG. 7

