



US00D888070S

(12) **United States Design Patent**  
**Yusupov et al.**

(10) **Patent No.:** **US D888,070 S**  
(45) **Date of Patent:** **\*\* Jun. 23, 2020**

(54) **DISPLAY SCREEN WITH TRANSITIONAL GRAPHICAL USER INTERFACE**

(71) Applicant: **Intermedia Labs, Inc.**, New York, NY (US)

(72) Inventors: **Ruslan Yusupov**, New York, NY (US); **Darren Scott Cummings**, London (GB); **Russell Scott Wyner**, Brooklyn, NY (US); **Marcus Eckert**, Berlin (DE)

(73) Assignee: **Intermedia Labs, Inc.**, New York, NY (US)

(\*\*) Term: **15 Years**

(21) Appl. No.: **29/647,505**

(22) Filed: **May 14, 2018**

**Related U.S. Application Data**

(63) Continuation-in-part of application No. 29/641,216, filed on Mar. 20, 2018.

(51) **LOC (12) Cl.** ..... **14-04**

(52) **U.S. Cl.**  
USPC ..... **D14/485**

(58) **Field of Classification Search**  
USPC ..... D14/485-488; D20/10, 11, 12, 22-32, D20/35

(Continued)

(56) **References Cited**

**U.S. PATENT DOCUMENTS**

1,286,380 A \* 12/1918 Matthews ..... G09F 7/22 40/421

D231,712 S 5/1974 Snitzel  
(Continued)

**FOREIGN PATENT DOCUMENTS**

EM 001694225-0014 4/2010  
EM 001928045-0001 6/2011

(Continued)

**OTHER PUBLICATIONS**

HQ Trivia—Thursday, Oct. 19, 2017, by Mendelson3, YouTube [online], published on Oct. 19, 2017, [retrieved on Jul. 27, 2018], retrieved from the Internet <URL: https://www.youtube.com/watch?v=in-Px\_sOQdE> (Year: 2017).\*

(Continued)

*Primary Examiner* — Cathron C Brooks

*Assistant Examiner* — Ian F Whitmore

(74) *Attorney, Agent, or Firm* — Wolf, Greenfield & Sacks, P.C.

(57) **CLAIM**

The ornamental design for a display screen with transitional graphical user interface, as shown and described.

**DESCRIPTION**

FIG. 1 is a first image in a sequence showing a front view of a display screen with transitional graphical user interface; FIG. 2 is a second image in the sequence thereof; FIG. 3 is a third image in the sequence thereof; FIG. 4 is a fourth image in the sequence thereof; and, FIG. 5 is a fifth image in the sequence thereof.

The long dash-short dash lines surrounding the images are drawn to illustrate the portion of the computer screen on which the design is displayed, and the long dash-short dash lines form no part of the claimed design. The even dash-dash broken lines illustrate portions of the environment of the claimed design and form no part of the claimed design. The white tone shown in the drawings forms no part of the claimed design.

The diagonal line patterns of FIGS. 3-5 illustrate areas of contrasting appearance. The appearance of the display screen with transitional graphical user interface sequentially transitions between the images shown in FIGS. 1-5. The process or period in which one image transitions to another image forms no part of the claimed design.

**1 Claim, 5 Drawing Sheets**

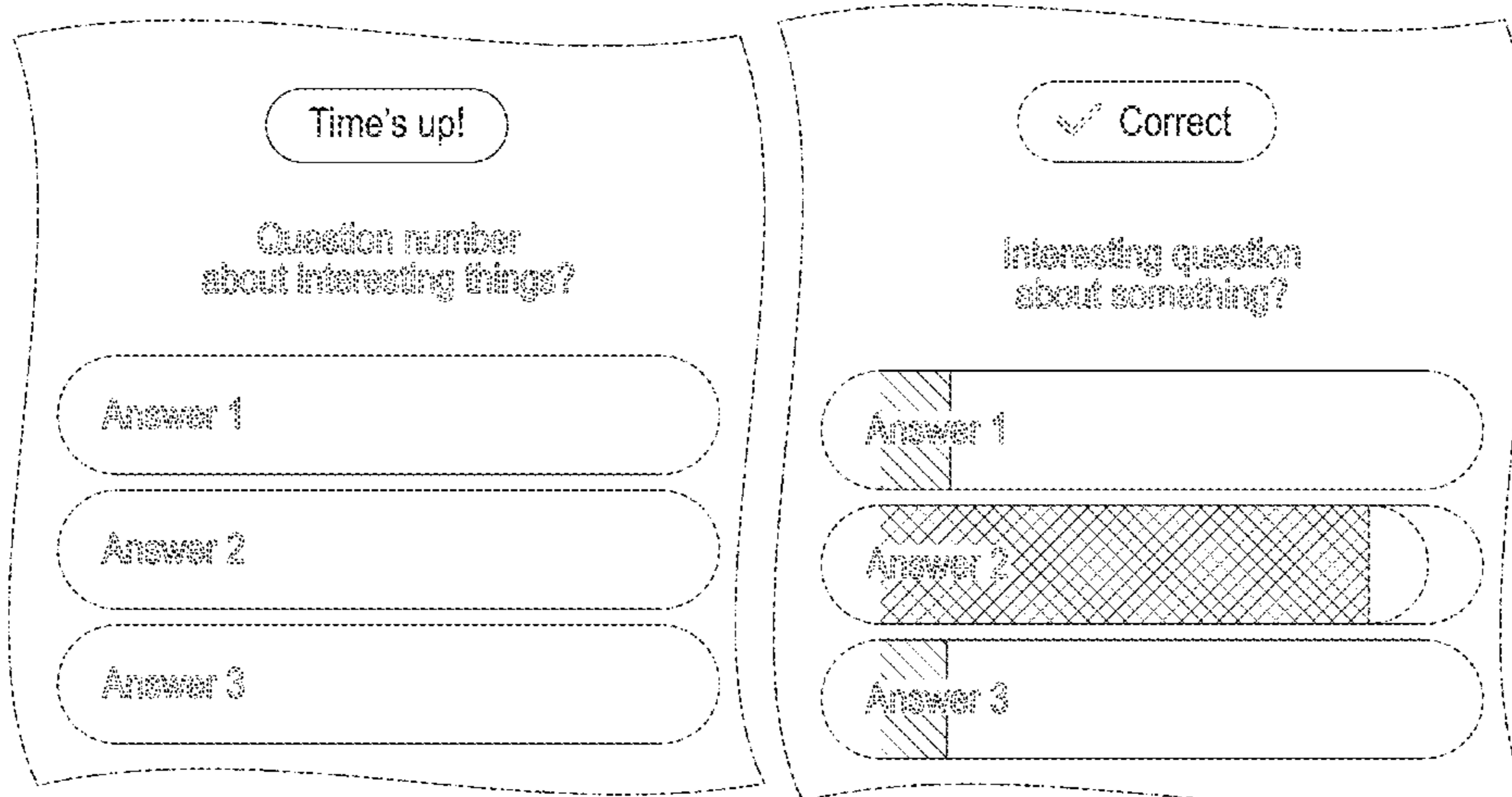

(58) **Field of Classification Search**  
 CPC ..... G06F 3/048-04897; G06F 2203/04802;  
 A63F 2300/308; A63F 13/53; G01C  
 21/36; G06K 9/00671; G11B 27/022;  
 G11B 27/031; H04M 1/72547  
 See application file for complete search history.

(56) **References Cited**

U.S. PATENT DOCUMENTS

D411,321 S 6/1999 Norman  
 D426,206 S 6/2000 Richter  
 6,267,379 B1 7/2001 Forrest et al.  
 D471,239 S 3/2003 Schaller  
 D543,992 S 6/2007 Vigesaa  
 D565,583 S 4/2008 Gunn et al.  
 D570,863 S 6/2008 Chen  
 D578,544 S 10/2008 Nathan et al.  
 D588,606 S 3/2009 Nathan et al.  
 D595,731 S \* 7/2009 Vu ..... D14/488  
 7,565,681 B2 \* 7/2009 Ngo ..... H04N 7/17336  
 725/101  
 D624,929 S 10/2010 Agnetta et al.  
 D644,663 S 9/2011 Gardner et al.  
 8,121,901 B2 \* 2/2012 Blanchard, Jr. .... G06Q 20/20  
 705/26.1  
 D664,596 S 7/2012 Luberto  
 D667,421 S 9/2012 Kriese et al.  
 D674,021 S 1/2013 Luberto  
 D681,046 S \* 4/2013 Davis ..... D14/486  
 D684,180 S 6/2013 Chutani et al.  
 D689,887 S 9/2013 Meng et al.  
 D707,245 S \* 6/2014 Bruck ..... D14/486  
 D719,974 S 12/2014 Knutson et al.  
 D722,077 S 2/2015 Zhang et al.  
 D726,214 S 4/2015 Wantland et al.  
 D727,955 S \* 4/2015 Ray ..... D14/488  
 D727,958 S \* 4/2015 Ray ..... D14/488  
 D731,538 S 6/2015 Lee  
 D734,345 S 7/2015 Kadosh  
 D741,354 S 10/2015 Lee et al.  
 D741,903 S 10/2015 Verma et al.  
 9,161,066 B1 10/2015 Oztaskent et al.  
 D744,527 S 12/2015 Sanderson  
 D745,551 S 12/2015 Kapur et al.  
 D748,143 S 1/2016 Kwon et al.  
 D749,625 S 2/2016 Yang et al.  
 D750,125 S 2/2016 Yang et al.  
 D753,167 S 4/2016 Yu et al.  
 D757,070 S \* 5/2016 Dziuba ..... D14/486  
 D757,072 S 5/2016 Seo et al.  
 D758,420 S \* 6/2016 Zhou ..... D14/488  
 D759,112 S 6/2016 Riske et al.  
 D759,704 S 6/2016 Kettner et al.  
 D760,261 S 6/2016 Yu et al.  
 D763,898 S 8/2016 Raykovich et al.  
 D764,495 S \* 8/2016 Cartlidge ..... D14/485  
 D764,528 S 8/2016 Choi et al.  
 D765,105 S \* 8/2016 Virk ..... D14/485  
 D765,111 S 8/2016 Cole  
 9,424,235 B2 \* 8/2016 Chamberlain ..... G06F 17/212  
 D766,972 S 9/2016 Millares et al.  
 D769,898 S 10/2016 Lee et al.  
 D770,485 S 11/2016 Olsson et al.  
 D774,068 S \* 12/2016 Derby ..... D14/486  
 D777,747 S \* 1/2017 Derby ..... D14/486  
 D781,887 S \* 3/2017 Dziuba ..... D14/486  
 D782,526 S 3/2017 Rind et al.  
 D782,527 S 3/2017 Rind et al.  
 D783,032 S 4/2017 Cashner et al.  
 D783,657 S \* 4/2017 Pitman ..... D14/486  
 D784,397 S 4/2017 Kim et al.  
 9,615,065 B2 \* 4/2017 Frenette ..... G06F 3/04842  
 9,632,013 B2 \* 4/2017 Rivas ..... G01N 1/10  
 D787,550 S 5/2017 Ollila et al.  
 D789,394 S 6/2017 Mandawat et al.  
 D789,977 S \* 6/2017 Mijatovic ..... D14/488

D789,978 S \* 6/2017 Mijatovic ..... D14/488  
 D791,180 S 7/2017 Sun  
 D795,921 S 8/2017 Bhatti et al.  
 D796,522 S \* 9/2017 L'Heureux ..... D14/485  
 D796,542 S 9/2017 Bhatti et al.  
 D797,142 S 9/2017 Prabhu  
 D799,512 S 10/2017 Johnston  
 D802,617 S \* 11/2017 Pitman ..... D14/486  
 D802,667 S 11/2017 Chan  
 D805,097 S 12/2017 Chaudhri et al.  
 D806,107 S \* 12/2017 Kim ..... D14/486  
 D809,548 S 2/2018 Anzures et al.  
 D813,270 S \* 3/2018 Stephens ..... D14/491  
 D814,513 S 4/2018 Bendert et al.  
 D815,663 S \* 4/2018 Dudey ..... D14/488  
 D821,423 S \* 6/2018 Von Reden ..... D14/486  
 D822,055 S \* 7/2018 Canna ..... D14/489  
 D825,608 S \* 8/2018 Andrizzi ..... D14/487  
 D830,401 S \* 10/2018 Mancuso ..... D14/486  
 D848,471 S \* 5/2019 Clymer ..... D14/487  
 D849,777 S \* 5/2019 Von Reden ..... D14/486  
 D850,462 S \* 6/2019 Hazel ..... D14/485  
 D851,669 S \* 6/2019 Baldi ..... D14/486  
 D852,213 S \* 6/2019 Clediere ..... D14/486  
 D854,041 S \* 7/2019 Alexander ..... D14/486  
 D854,047 S \* 7/2019 Stephens ..... D14/491  
 D860,226 S \* 9/2019 Fung ..... D14/485  
 D872,124 S \* 1/2020 Chu ..... D14/488  
 2002/0012322 A1 1/2002 Rooney  
 2003/0228909 A1 12/2003 Tanaka et al.  
 2005/0197189 A1 9/2005 Schultz  
 2006/0088683 A1 4/2006 Wilson  
 2008/0054571 A1 3/2008 Davidzon et al.  
 2008/0282286 A1 11/2008 Or  
 2008/0317979 A1 12/2008 Itakura et al.  
 2009/0013086 A1 1/2009 Greenbaum  
 2009/0228807 A1 \* 9/2009 Lemay ..... G06F 3/04817  
 715/752  
 2009/0325706 A1 12/2009 Geist, Jr. et al.  
 2010/0125791 A1 \* 5/2010 Katis ..... H04M 3/42221  
 715/716  
 2011/0314710 A1 12/2011 Luberto  
 2012/0315993 A1 12/2012 Dumont et al.  
 2013/0116044 A1 5/2013 Schwartz  
 2015/0066980 A1 \* 3/2015 Kim ..... G06F 17/30277  
 707/769  
 2015/0086174 A1 3/2015 Abecassis  
 2015/0089372 A1 \* 3/2015 Mandalia ..... G11B 27/10  
 715/720  
 2015/0149902 A1 5/2015 Zavesky et al.  
 2015/0193407 A1 \* 7/2015 Baluja ..... G06F 17/212  
 715/202  
 2016/0210270 A1 \* 7/2016 Kelly ..... G06Q 10/10  
 2016/0255140 A1 9/2016 Shattil  
 2016/0299670 A1 \* 10/2016 Breedvelt-Schouten .....  
 G06F 3/04847  
 2017/0182423 A1 6/2017 Leppinen et al.  
 2017/0237785 A1 8/2017 Peng et al.

FOREIGN PATENT DOCUMENTS

KR 300837237.0000 1/2016  
 WO WO D078497-039 6/2012  
 WO WO D083159-020 8/2014  
 WO WO D098444-004 12/2017

OTHER PUBLICATIONS

Full Game The Q (Sunday Nov. 26, 2017), by The Q—Live Trivia, YouTube [online], published on Nov. 26, 2017, [retrieved on Jul. 27, 2018], retrieved from the Internet <URL: <https://www.youtube.com/watch?v=lfJsTnBn2NY>> (Year: 2017).\*

JusPlay Live Trivia Show | Feb. 28, by Jus Play, YouTube [online], published on Mar. 1, 2018, [retrieved on Jul. 27, 2018], retrieved from the Internet <URL: <https://www.youtube.com/watch?v=JBW6FT-IXF0>> (Year: 2018).\*

(56)

**References Cited**

## OTHER PUBLICATIONS

Genius—Live Quiz Game Show, by Genius Quiz, YouTube [online], published on Feb. 12, 2018, [retrieved on Jul. 27, 2018], retrieved from the Internet <URL: <https://www.youtube.com/watch?v=Ot5iaxSxejg>> (Year: 2018).\*

Game Mobile UI Design in Android Studio Tutorial, by Angga Risky, YouTube [online], published on Oct. 15, 2017, [retrieved on Jul. 27, 2018], retrieved from the Internet <URL: <https://www.youtube.com/watch?v=D5M29vOJU2M>> (Year: 2017).\*

E-Learning App III, by Margo, dribbble.com [online], published on Nov. 5, 2015, [retrieved on Jul. 30, 2018], retrieved from the Internet <URL: <https://dribbble.com/shots/2336558-E-learning-app-III>> (Year: 2015).\*

Quiz, by Goetz, dribbble.com [online], published on Apr. 22, 2016, [retrieved on Jul. 30, 2018], retrieved from the Internet <URL: <https://dribbble.com/shots/2668235-Quiz>> (Year: 2016).\*

Quiz Wars, by Nazuir, dribbble.com [online], published on Feb. 2, 2017, [retrieved on Jul. 30, 2018], retrieved from the Internet <URL: <https://dribbble.com/shots/3260132-Quiz-Wars>> (Year: 2017).\*

Trivia App—QuizMix, by Bany, published on Jan. 31, 2018, [retrieved on May 13, 2019], retrieved from the Internet [URL: <https://dribbble.com/shots/4167449-Trivia-app-QuizMix>] (Year: 2018).\*

Live Trivia & Quiz Game Show, by Aashna, published on Feb. 19, 2018, [retrieved on May 13, 2019], retrieved from the Internet [URL: <https://dribbble.com/shots/4241969-Live-Trivia-Quiz-game-Show>] (Year: 2018).\*

Braid Weave, Diagonal Lines Seamless Textures, by blankstock, canstockphoto.com [online], published on May 2, 2016, [retrieved on May 13, 2019], retrieved from the Internet [URL: <https://www.canstockphoto.com/braid-weave-diagonal-lines-seamless-36608877.html>] (Year: 2016).\*

[No Author Listed], LabVIEW Graphical User Interface for LIRC. Diligent Blog. Feb. 2, 2017. Retrieved on Apr. 24, 2018: <https://blog.diligentinc.com/labview-graphical-user-interface-for-lirc/>.

[No Author Listed], LED GUI. [www.gamedevmarket.net](http://www.gamedevmarket.net). Retrieved on Apr. 24, 2018: <https://www.gamedevmarket.net/asset-led-gui-10301/>.

[No Author Listed], Vector-Vector graphical user interface UI GUI for 2d video games. Wooden menu, panels and buttons for menu. 123RF. Retrieved on Apr. 24, 2018: [http://www.123rf.com/photo\\_59034814\\_stock-vector-vector-graphical-user-interface-ui-gui-for-2d-video-games-wooden-menu-panels-and-buttons-for-menu-.html](http://www.123rf.com/photo_59034814_stock-vector-vector-graphical-user-interface-ui-gui-for-2d-video-games-wooden-menu-panels-and-buttons-for-menu-.html).

[No Author Listed], Screen Captures Taken from “HQ Trivia—Thursday, Oct. 19, 2017 12pm PDT—Full Game.” Intermedia Labs, Inc. Full video available at [https://www.youtube.com/watch?v=inPX\\_sOQdE](https://www.youtube.com/watch?v=inPX_sOQdE).

[No Author Listed], Screen Captures Taken From Full Game the Q (Saturday Nov. 30, 2017 5pm EST). The Q. Full video available at <https://www.youtube.com/watch?v=zbRPntvQW40>.

Aung et al., Augmented reality-based RehaBio system for shoulder rehabilitation. *International Journal of Mechatronics and Automation*. Jan. 2014; 4(1):52-62. Retrieved on Apr. 24, 2018: [https://www.researchgate.net/publication/264812966\\_Augmented\\_reality-based\\_RehaBio\\_system\\_for\\_shoulders\\_rehabilitation](https://www.researchgate.net/publication/264812966_Augmented_reality-based_RehaBio_system_for_shoulders_rehabilitation).

[No Author Listed], DressagePro /HQ-Logo, posted on Mar. 31, 2017, © 2019 Freebie Supply [online], [site visited Mar. 11, 2019]. Available from Internet, <URL: <https://dressagepro.com/hq-logo/>>.

[No Author Listed], Freebie Supply /Logos /HQ Logo, posted on Apr. 23, 2018, © 2019 Freebie Supply [online], [site visited Mar. 11, 2019]. Available from Internet, <URL: <https://freebiesupply.com/logos/hq-logo/>>.

[No Author Listed], Google Play/ Store/ Apps / Intermedia Labs, posted on Dec. 24, 2017, © 2019 Google [online], [site visited Mar. 11, 2019]. Available from Internet, <URL: <https://play.google.com/store/apps/dev?id=8025251125525325507/>>.

\* cited by examiner

Question number  
about interesting thing?

Answer 1

Answer 2

Answer 3

A dashed-line form with a question and three answer fields. The question is "Question number about interesting thing?". The three answer fields are labeled "Answer 1", "Answer 2", and "Answer 3".

FIG. 1

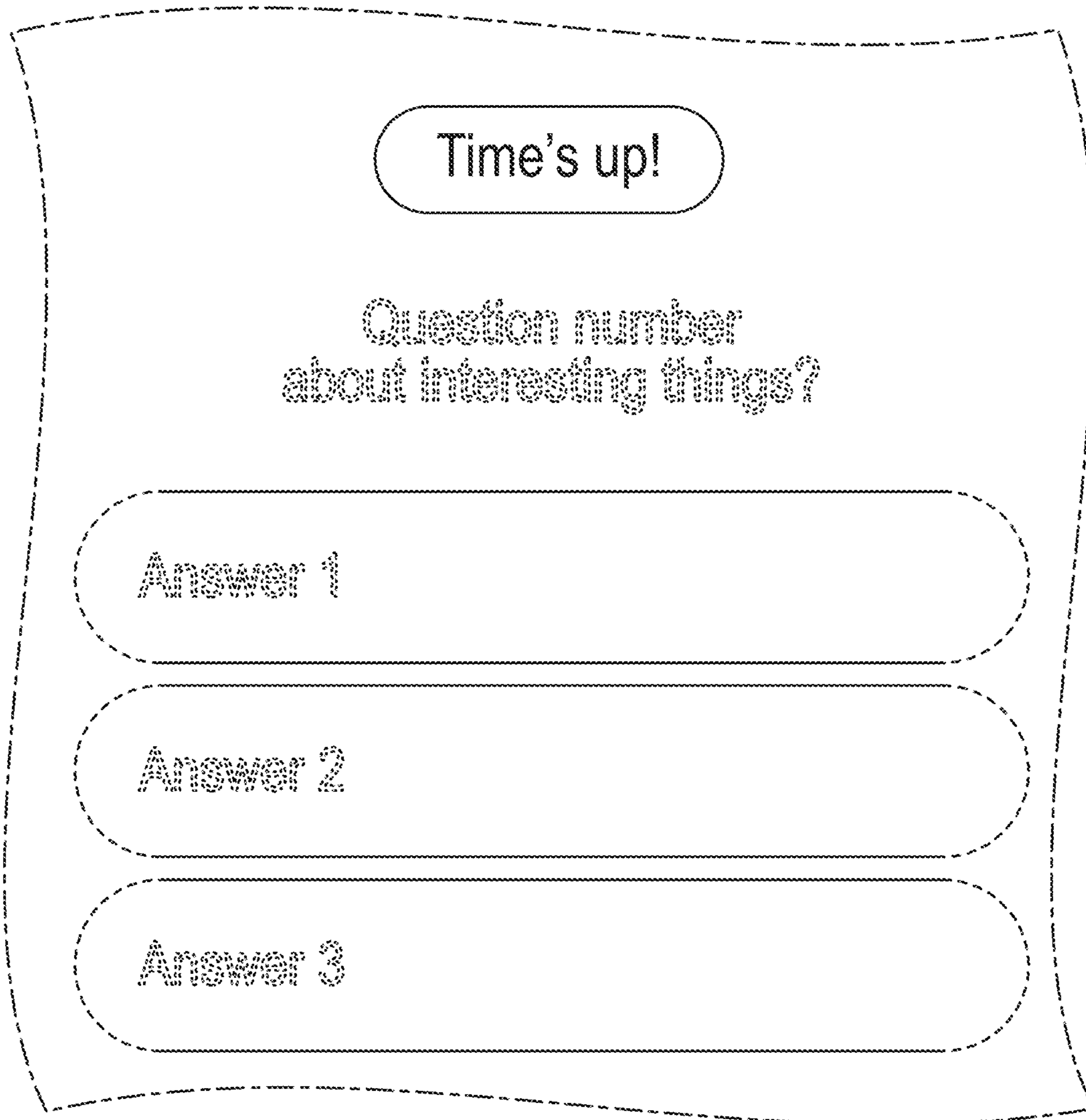

FIG. 2

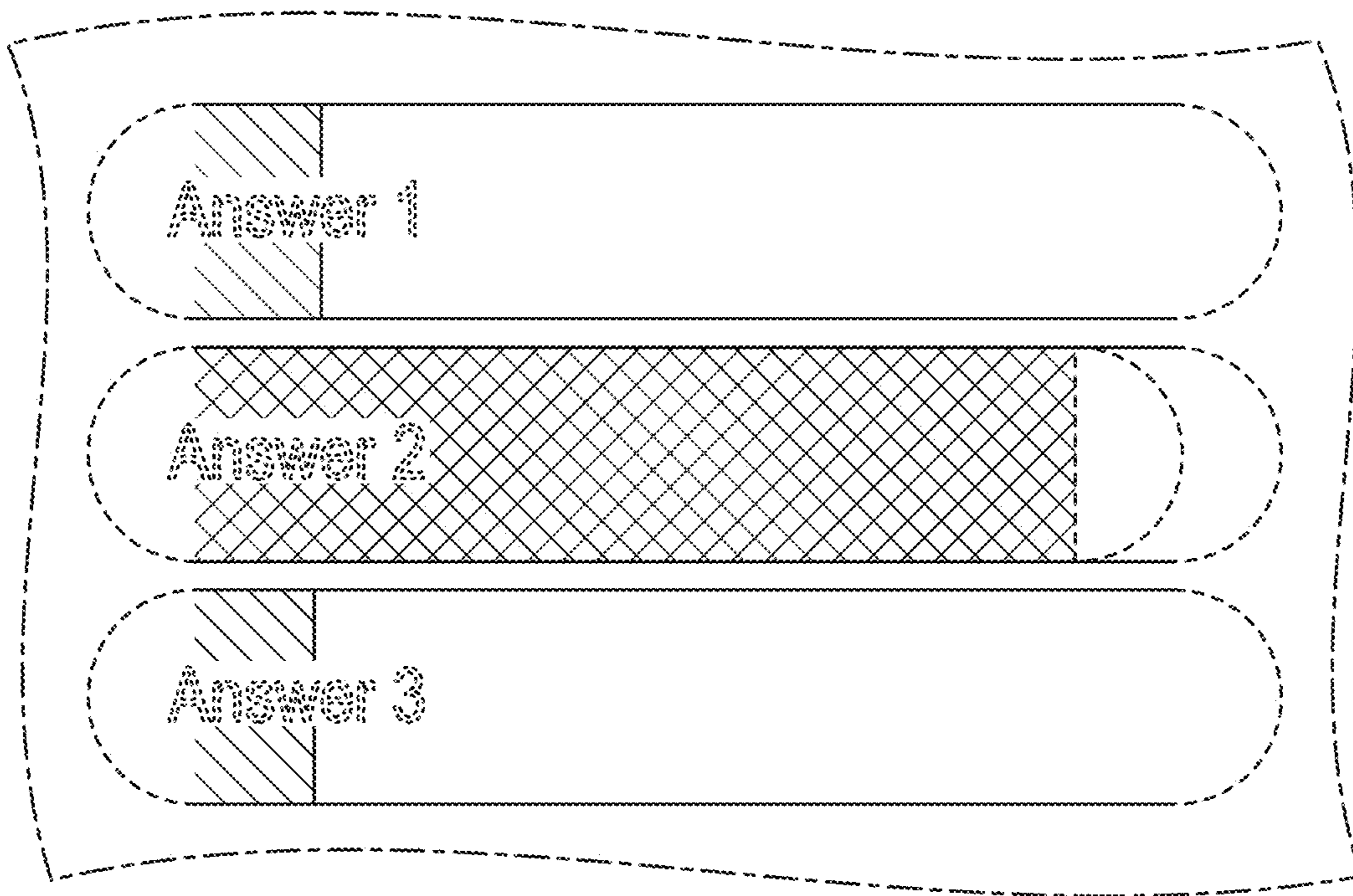

FIG. 3

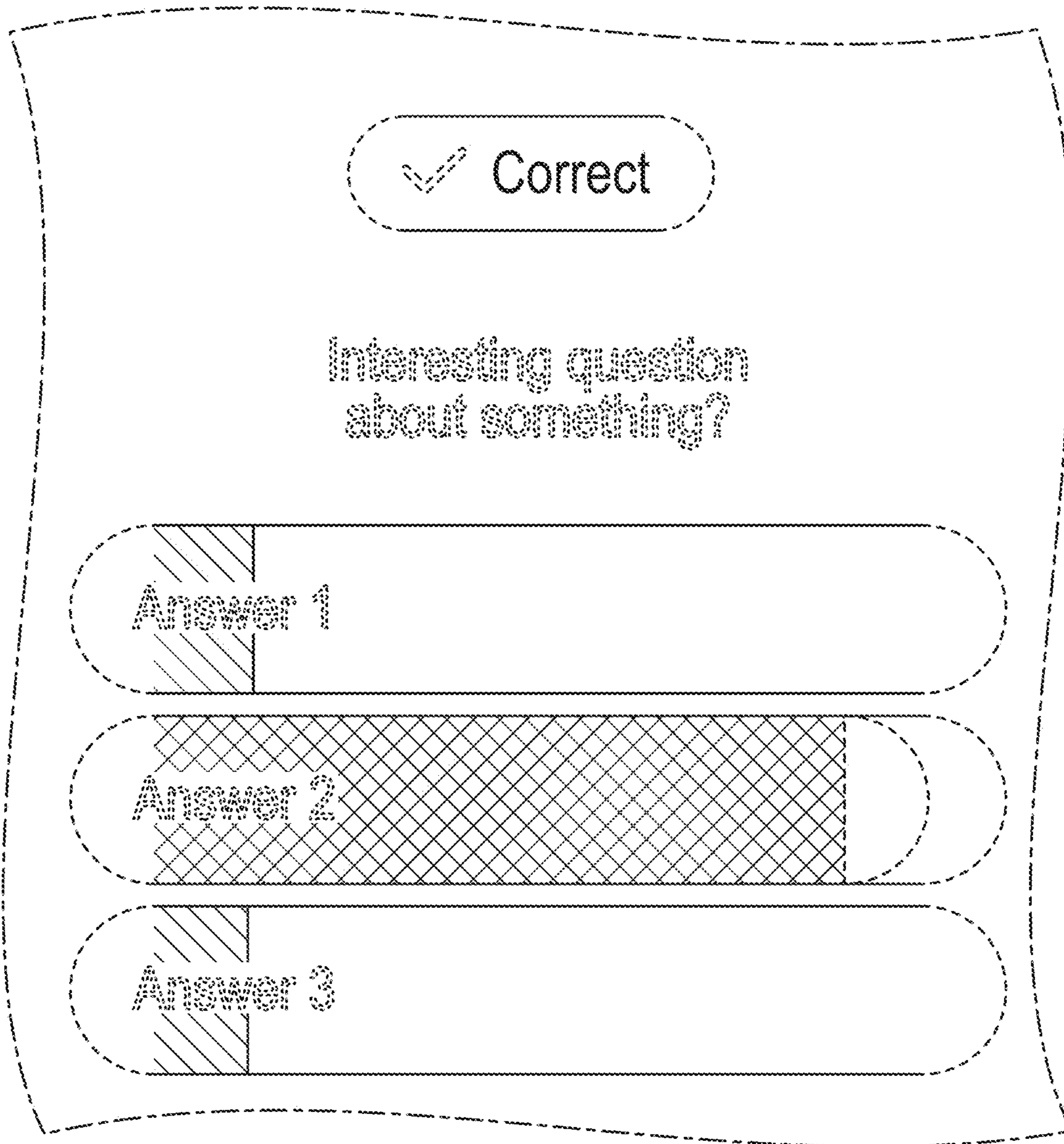

FIG. 4

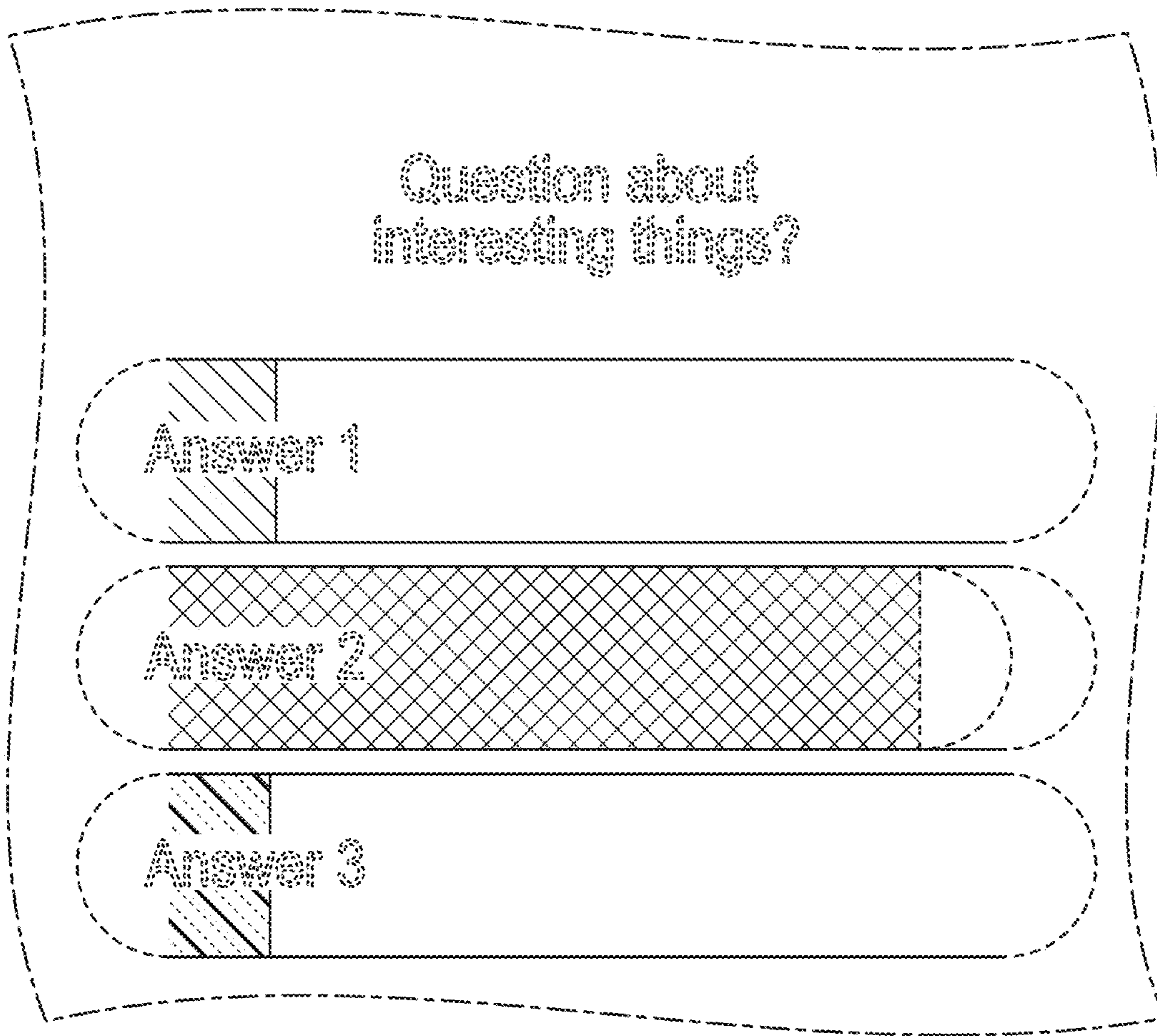

FIG. 5