



US00D887950S

(12) **United States Design Patent**  
**Evulet et al.**

(10) **Patent No.:** **US D887,950 S**  
(45) **Date of Patent:** **\*\* \*Jun. 23, 2020**

(54) **FLYING CAR**

(71) Applicant: **JETOPTERA, INC.**, Edmonds, WA (US)

(72) Inventors: **Andrei Evulet**, Edmonds, WA (US);  
**John Hawkins**, Austin, TX (US)

(73) Assignee: **JETOPTERA, INC.**, Edmonds, WA (US)

(\*) Notice: This patent is subject to a terminal disclaimer.

(\*\*) Term: **15 Years**

(21) Appl. No.: **29/625,627**

(22) Filed: **Nov. 10, 2017**

(51) **LOC (12) Cl.** ..... **12-01**

(52) **U.S. Cl.**  
USPC ..... **D12/335**; D12/4

(58) **Field of Classification Search**  
USPC ..... D12/319–345, 1–4, 16.1, 214;  
D21/436–454; D30/160  
CPC ..... B64C 29/0025; B64C 2201/108; B64C  
2201/048; B64C 2201/088; B64C 29/00;  
B64C 29/0058; B64C 39/001; B64C  
39/024; B64C 39/062; B64C 2201/141;  
B64C 27/12

See application file for complete search history.

(56) **References Cited**

**U.S. PATENT DOCUMENTS**

D82,314 S *	10/1930	Christmas	.....	D12/335
D91,444 S *	1/1934	Shelton	.....	D12/335
D97,361 S *	10/1935	Swanson	.....	D12/335
D97,652 S *	11/1935	Swanson	.....	D12/335
D98,660 S *	2/1936	Burnelli	.....	D12/335
D100,608 S *	7/1936	Taylor et al.	.....	D12/335
D100,609 S *	7/1936	Wilson et al.	.....	D12/335

D101,928 S *	11/1936	Wilson et al.	.....	D12/331
D103,290 S *	2/1937	Wendt	.....	D12/324
D106,275 S *	10/1937	Bellanca	.....	D12/335
D112,834 S *	1/1939	Seversky	.....	244/45 R
2,147,968 A *	2/1939	Delanne	.....	B64C 39/00 244/119
D113,649 S *	3/1939	Abrams	.....	244/91
D114,122 S *	4/1939	Martin	.....	244/105
D114,626 S *	5/1939	Taylor et al.	.....	244/119
D115,854 S *	7/1939	Loudy	.....	244/13
D119,714 S *	3/1940	Hibbard	.....	244/13
D123,427 S *	11/1940	Brandrup	.....	D12/335
D126,067 S *	3/1941	Boushey	.....	D12/335
D129,412 S *	9/1941	Nebesar	.....	D12/324
D130,651 S *	12/1941	Silverstein	.....	244/13
RE22,029 E *	2/1942	Nebesar	.....	B64C 39/04 244/13
D133,126 S *	7/1942	Woods	.....	D12/335
D133,777 S *	9/1942	Gardenhire	.....	244/49
D135,994 S *	7/1943	Floren	.....	244/215
D135,995 S *	7/1943	Floren	.....	244/215

(Continued)

**OTHER PUBLICATIONS**

Jetoptera by Electric VTOL News. dated May 2018. found online [Mar. 15, 2019] <http://evtol.news/aircraft/jetoptera-j2000/>\*

*Primary Examiner* — Marissa J Cash

(74) *Attorney, Agent, or Firm* — Foster Garvey PC

(57) **CLAIM**

We claim the ornamental design for a flying car, as shown.

**DESCRIPTION**

FIG. 1 is a top plan view of a flying car, showing my new design;

FIG. 2 is a bottom plan view thereof;

FIG. 3 is a left side elevation view thereof;

FIG. 4 is a right side elevation view thereof;

FIG. 5 is a front elevation view thereof; and,

FIG. 6 is a rear elevation view thereof.

**1 Claim, 5 Drawing Sheets**

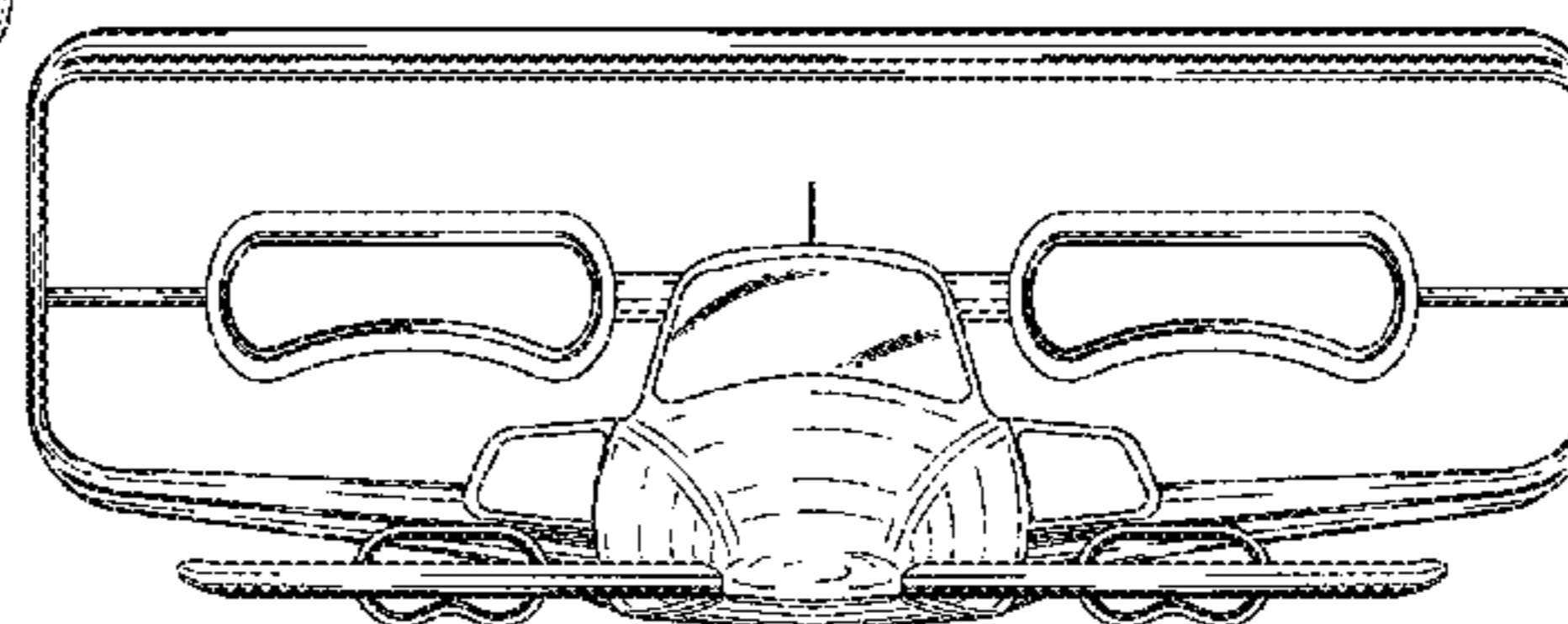
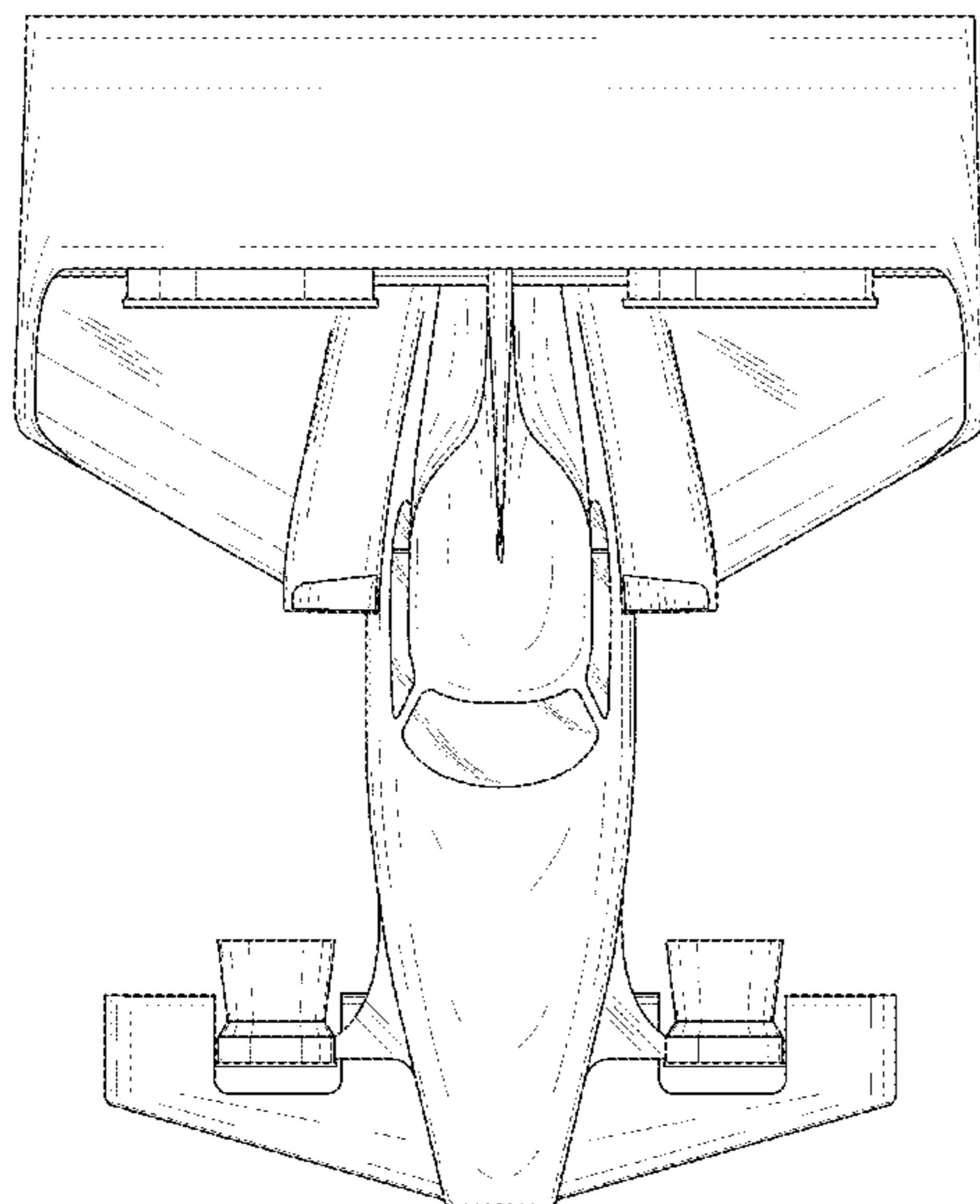

(56)

References Cited

U.S. PATENT DOCUMENTS

D136,078 S *	8/1943	Novikoff	244/106	D245,157 S *	7/1977	Seidel	D12/333
D136,249 S *	8/1943	Burnelli	D12/333	D250,727 S *	1/1979	Venditti	D21/450
D136,296 S *	8/1943	Szyncer	244/16	D250,786 S *	1/1979	Venditti	D21/450
D138,102 S *	6/1944	Kelly	244/106	D250,852 S *	1/1979	Maloney, II	D21/450
D138,217 S *	7/1944	Van Zelm	244/13	D268,107 S *	3/1983	Enav	244/15
D138,218 S *	7/1944	Van Zelm	244/13	D273,005 S *	3/1984	McComas	D12/335
D138,795 S *	9/1944	Stoughton	244/45 R	D274,510 S *	7/1984	McComas	D12/338
D139,028 S *	10/1944	Stout	244/45 R	D292,203 S *	10/1987	Ligeti	D12/319
D139,438 S *	11/1944	Hughes et al.	244/13	D292,910 S *	11/1987	McGiboney	D12/331
D140,113 S *	1/1945	Biasell	244/13	4,746,082 A *	5/1988	Syms	B64D 47/08 244/118.2
D140,220 S *	1/1945	Thieblot	244/45 R	D301,867 S *	6/1989	Street	D12/339
D143,729 S *	2/1946	Hall et al.	244/74	D308,043 S *	5/1990	Butler	D12/331
D143,730 S *	2/1946	Hall et al.	244/74	D311,720 S *	10/1990	Butler	D12/331
D143,731 S *	2/1946	Hall et al.	244/74	D312,068 S *	11/1990	Moller	D12/319
D143,732 S *	2/1946	Hall et al.	244/74	D319,805 S *	9/1991	Wiegert	D12/319
D143,820 S *	2/1946	Hibbard et al.	244/13	D323,315 S *	1/1992	Haga	D12/328
D144,211 S *	3/1946	Northrop et al.	244/37	5,078,339 A *	1/1992	Lapidot	B64C 3/56 244/49
D144,938 S *	6/1946	Schmued	244/36	5,115,996 A *	5/1992	Moller	B64C 29/0025 239/265.19
D148,595 S *	2/1948	Thieblot	244/45 R	5,415,365 A *	5/1995	Ratliff	B64C 35/00 114/271
D157,645 S *	3/1950	Thieblot	D12/335	5,503,352 A *	4/1996	Eger	B64C 39/068 244/13
D159,110 S *	6/1950	Thieblot	244/13	D371,105 S *	6/1996	Graham	D12/319
D159,198 S *	7/1950	Greenwood et al.	D12/335	D381,952 S *	8/1997	Carter, Jr.	D12/327
D160,841 S *	11/1950	Burnelli	244/13	D392,937 S *	3/1998	Brichard	D12/319
D160,842 S *	11/1950	Burnelli	244/13	D414,740 S *	10/1999	Margaritoff	D12/319
D162,517 S *	3/1951	Burnelli	244/13	D418,805 S *	1/2000	Cycon	244/12.3
D163,722 S *	6/1951	Vinje	244/2	D431,522 S *	10/2000	Fujino	D12/337
D164,371 S *	8/1951	Voque	D12/335	D442,540 S *	5/2001	Cellini	D12/308
D164,843 S *	10/1951	Burnelli	D12/333	D446,182 S *	8/2001	Adam, Jr.	D12/319
2,752,114 A *	6/1956	Calvy	B60J 5/125 244/118.3	D466,858 S *	12/2002	Carroll	D12/337
D179,811 S *	3/1957	Messerschmid	D12/327	D467,533 S *	12/2002	Han	D12/319
D185,535 S *	6/1959	Coleman	D12/333	D486,776 S *	2/2004	Carr	D12/319
D185,546 S *	6/1959	Geraci	244/45 R	D500,729 S *	1/2005	Wilding	D12/319
D190,534 S *	6/1961	Smolinski	D12/330	D500,981 S *	1/2005	Wilding	D12/319
3,017,139 A *	1/1962	Binder	B64C 39/062 244/12.6	D543,248 S *	5/2007	Winston	D21/450
D192,195 S *	2/1962	Stepniewski	D12/330	D738,438 S *	9/2015	Cummings	D21/447
D192,337 S *	3/1962	Skaggs	D12/335	9,120,560 B1 *	9/2015	Armer	B64C 29/0008
D192,665 S *	4/1962	Stepniewski	D12/335	D743,868 S *	11/2015	Cummings	D12/328
3,049,320 A *	8/1962	Fletcher	B64C 29/0033 244/12.4	D763,733 S *	8/2016	Gattelli	D12/16.1
D197,933 S *	4/1964	Sumner	D12/324	9,783,288 B1 *	10/2017	Moore	B64C 27/322
D202,260 S *	9/1965	McConologue	D12/335	D810,621 S *	2/2018	Sadek	D12/16.1
D203,283 S *	12/1965	Woods	244/13	9,932,118 B2 *	4/2018	Bak	B64D 27/24
D203,720 S *	2/1966	Jarchow	D12/335	10,124,890 B2 *	11/2018	Sada-Salinas	B64C 29/0025
D231,603 S *	5/1974	Krivka	D12/327	10,183,744 B2 *	1/2019	Gamble	B64C 29/0025
3,834,654 A *	9/1974	Miranda	B64C 39/068 244/13	2012/0043413 A1 *	2/2012	Smith	B64C 29/0033 244/12.4
D238,888 S *	2/1976	Bradley	D21/833	2017/0072755 A1 *	3/2017	Zhou	B64C 29/0075
D239,274 S *	3/1976	Snyder	D12/335	2017/0300067 A1 *	10/2017	Douglas	B64C 29/0025
D239,522 S *	4/1976	Wheatley	D12/335	2018/0305007 A1 *	10/2018	Evulet	B64C 29/005
D240,909 S *	8/1976	Whitener	D12/335				

\* cited by examiner

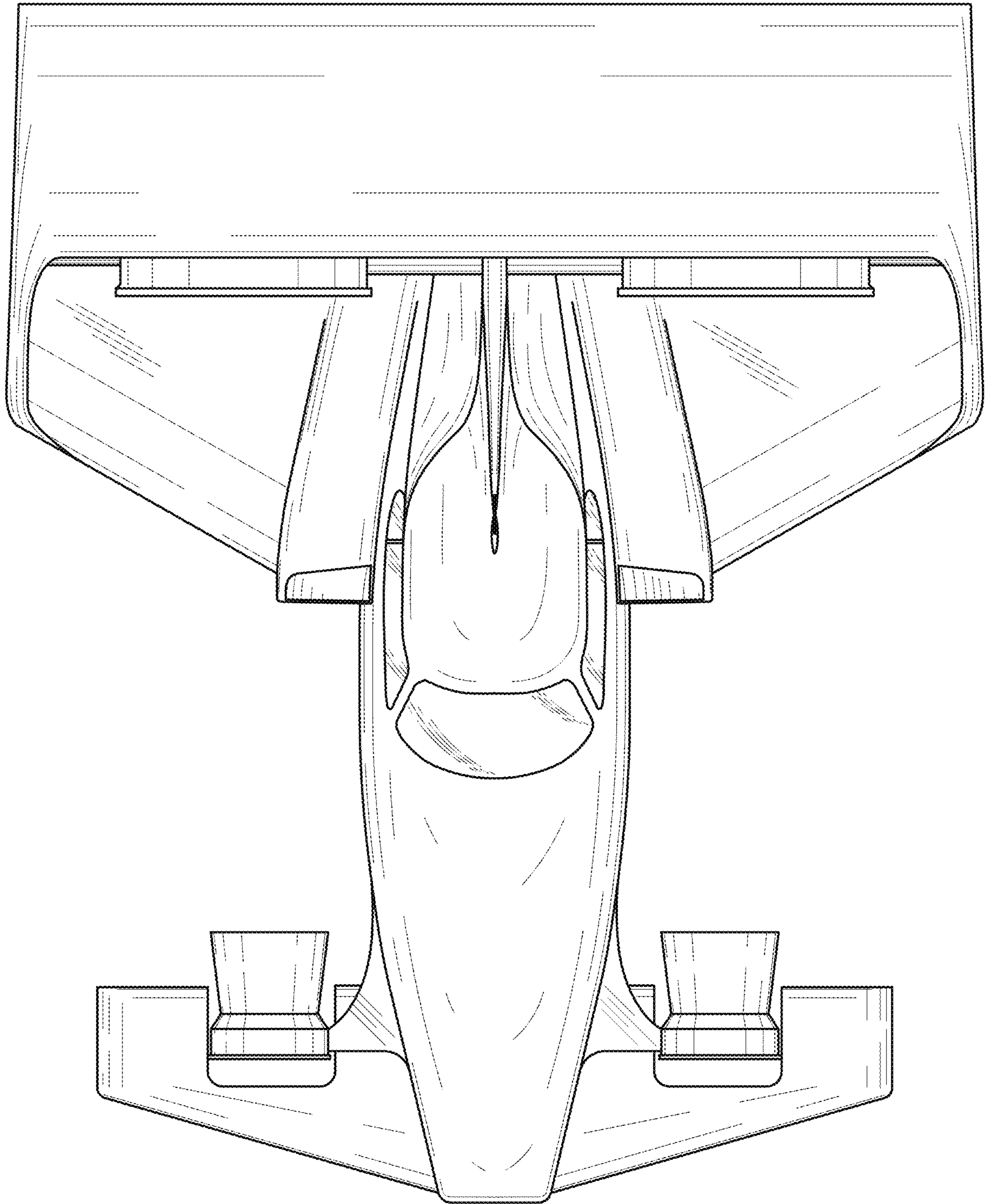

*Fig. 1*

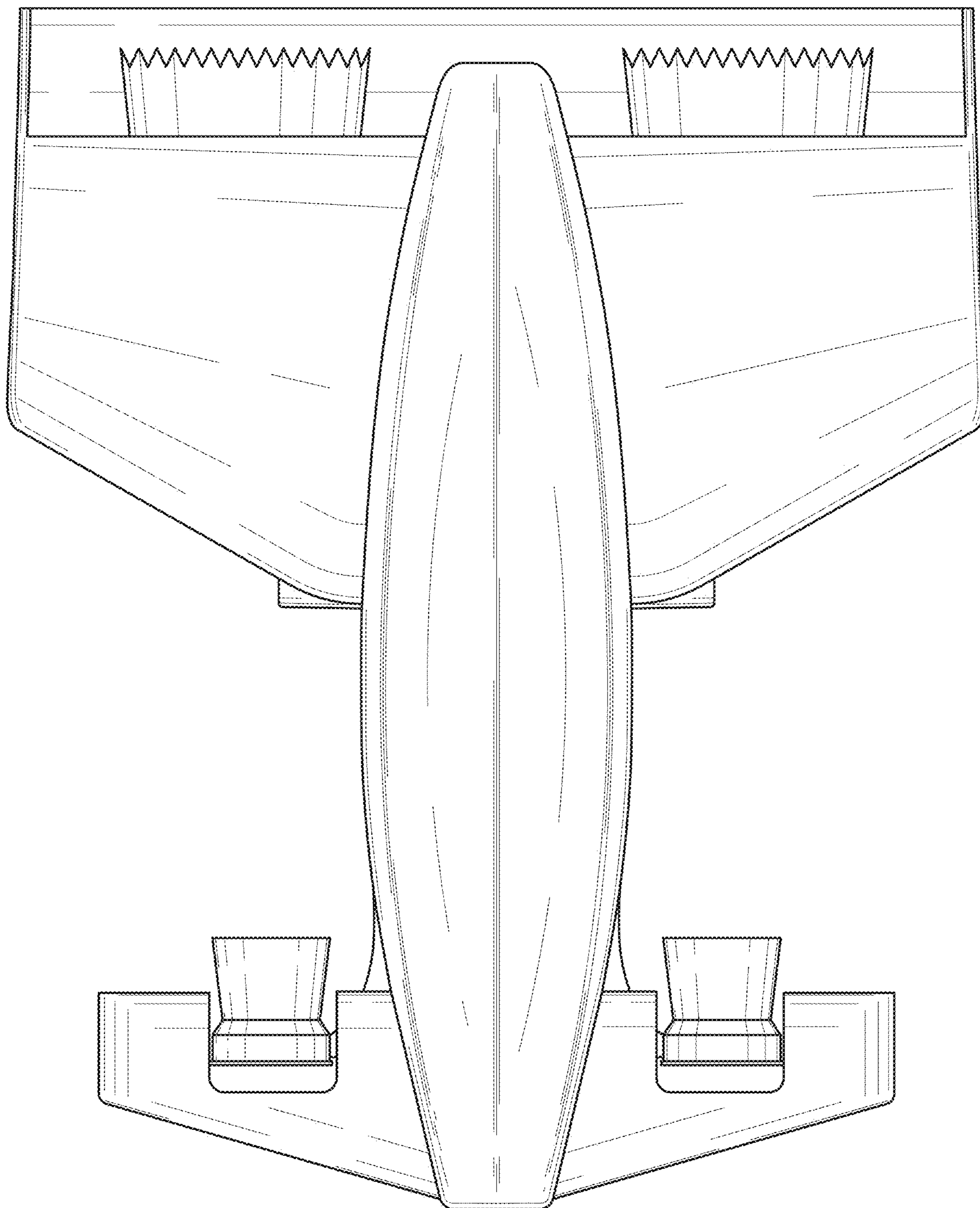

*Fig. 2*

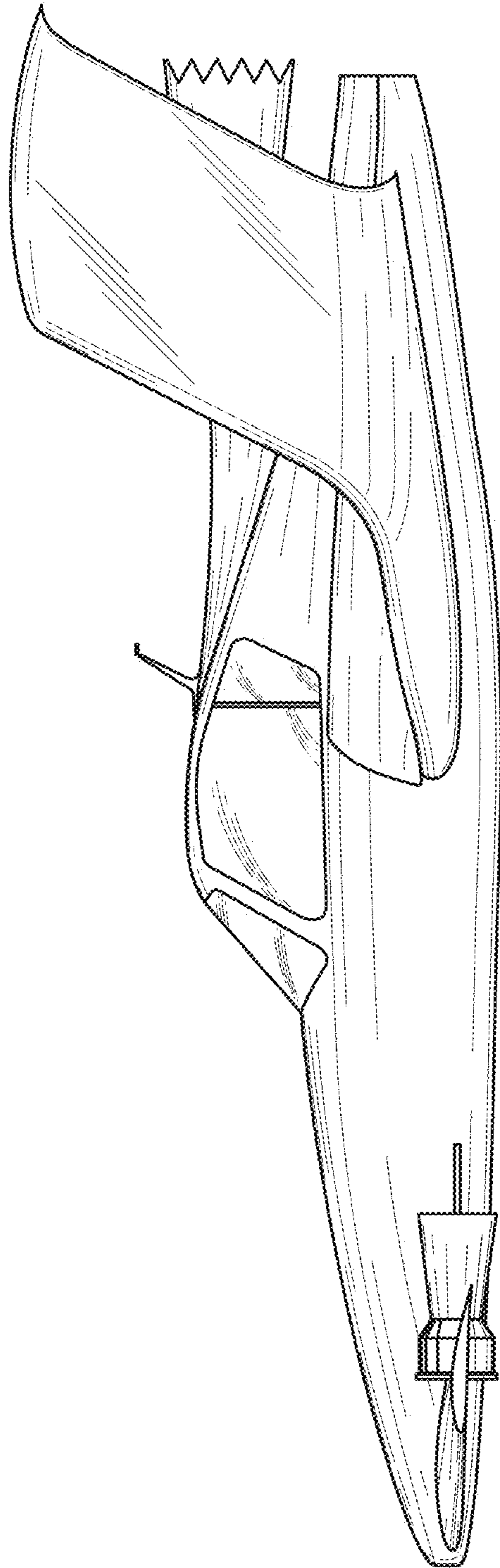

*Fig. 3*

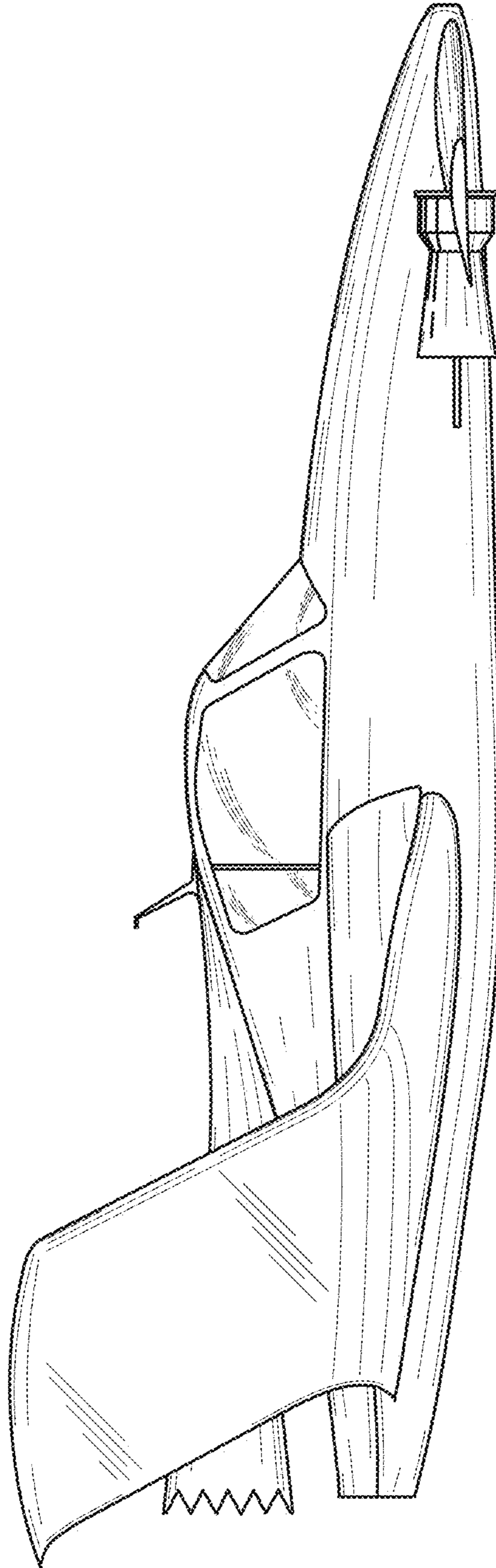

*Fig. 4*

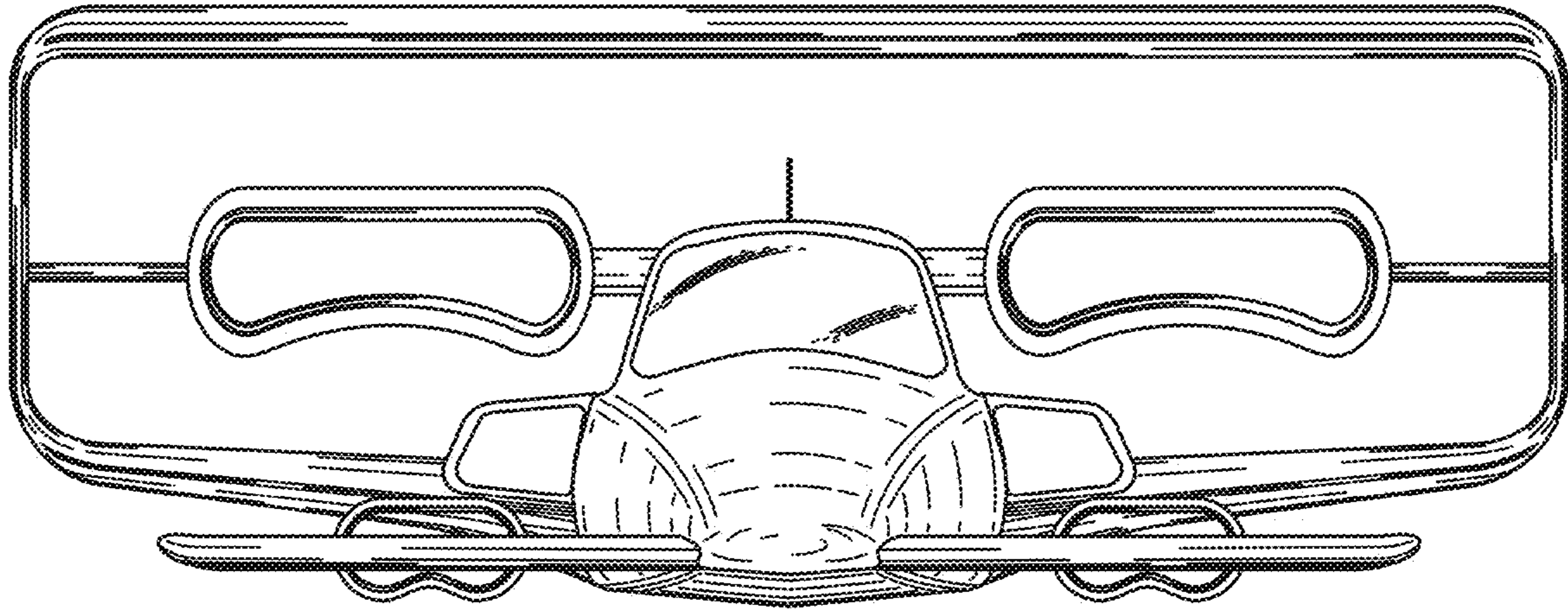

*Fig. 5*

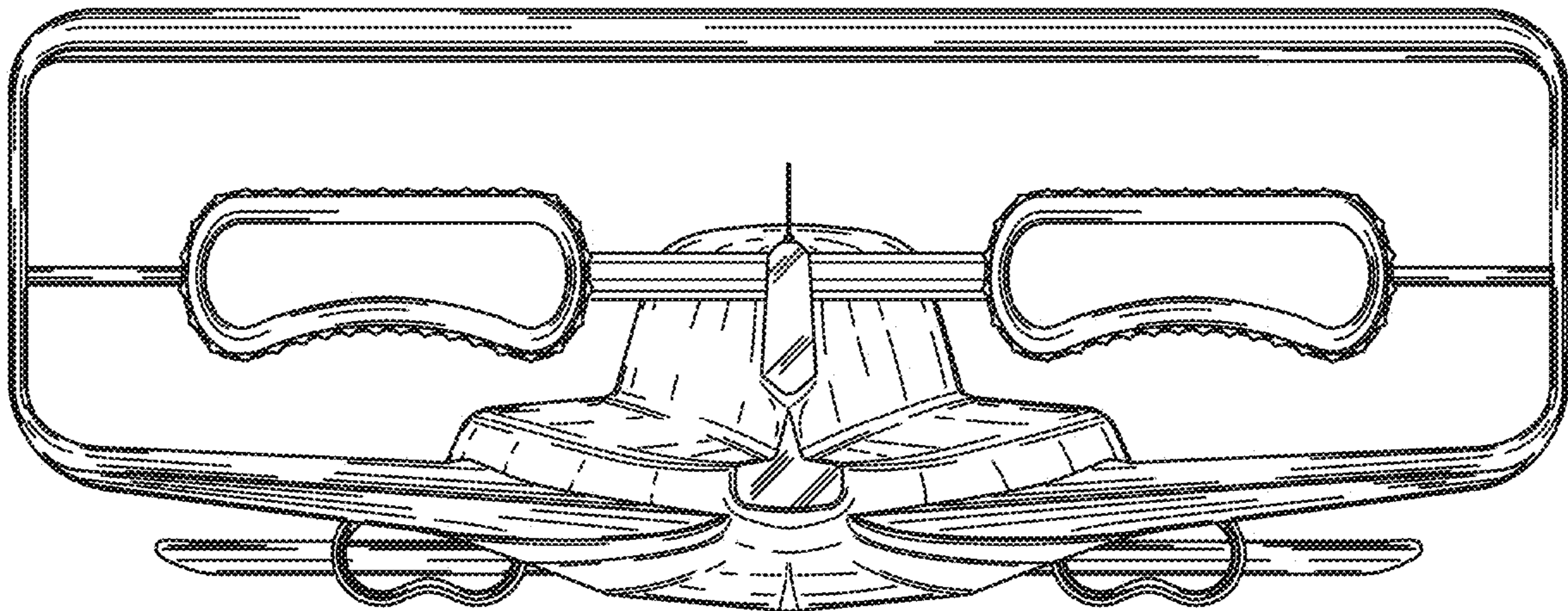

*Fig. 6*