



US00D887921S

(12) **United States Design Patent**
Harriton et al.

(10) **Patent No.:** **US D887,921 S**
(45) **Date of Patent:** **** Jun. 23, 2020**

(54) **VEHICLE REAR BUMPER**

(71) Applicant: **StreetCar ORV, LLC**, Wixom, MI (US)
(72) Inventors: **David Harriton**, Missoula, MT (US);
Mark Stouffer, Oakland Township, MI (US)
(73) Assignee: **StreetCar ORV LLC**, Wixom, MI (US)

(**) Term: **15 Years**

(21) Appl. No.: **29/668,325**

(22) Filed: **Oct. 30, 2018**

(51) **LOC (12) Cl.** **12-16**

(52) **U.S. Cl.**
USPC **D12/171; D12/169**

(58) **Field of Classification Search**
USPC D12/86, 90, 91, 92, 163, 164, 169, 171,
D12/196, 216
CPC B60R 19/02; B60R 19/18; B60R 19/24;
B60R 19/56; B60R 2019/007; B62D
25/0845
See application file for complete search history.

(56) **References Cited**

U.S. PATENT DOCUMENTS

7,703,834 B1 * 4/2010 Hardy B60R 9/06
296/102
D751,012 S * 3/2016 Hare D12/169

D777,619 S * 1/2017 Barajas D12/167
D792,817 S * 7/2017 McMath D12/169
D811,956 S * 3/2018 Zeng D12/169
D821,275 S * 6/2018 Eck D12/171
D830,919 S * 10/2018 Zeng D12/167
D832,161 S * 10/2018 Kobayashi D12/171
D845,847 S * 4/2019 Piscitelli D12/169
D846,460 S * 4/2019 Goodrich D12/169
D846,462 S * 4/2019 DiCanzio D12/171
D864,806 S * 10/2019 Wood D12/171
2017/0088076 A1 * 3/2017 Fujimoto B60R 19/04

* cited by examiner

Primary Examiner — Darlington Ly

(74) *Attorney, Agent, or Firm* — Quinn IP Law

(57) **CLAIM**

The ornamental design for a vehicle rear bumper, as shown and described.

DESCRIPTION

FIG. 1 is a top and front perspective view of a vehicle rear bumper showing my new design;
FIG. 2 is a front elevation view thereof;
FIG. 3 is a rear elevation view thereof;
FIG. 4 is a right side elevation view thereof;
FIG. 5 is a left side elevation view thereof;
FIG. 6 is a top plan view thereof;
FIG. 7 is a bottom plan view thereof; and,
FIG. 8 is a bottom and rear perspective view thereof.
The broken lines in the drawings illustrate portions of the vehicle rear bumper that form no part of the claimed design.

1 Claim, 5 Drawing Sheets

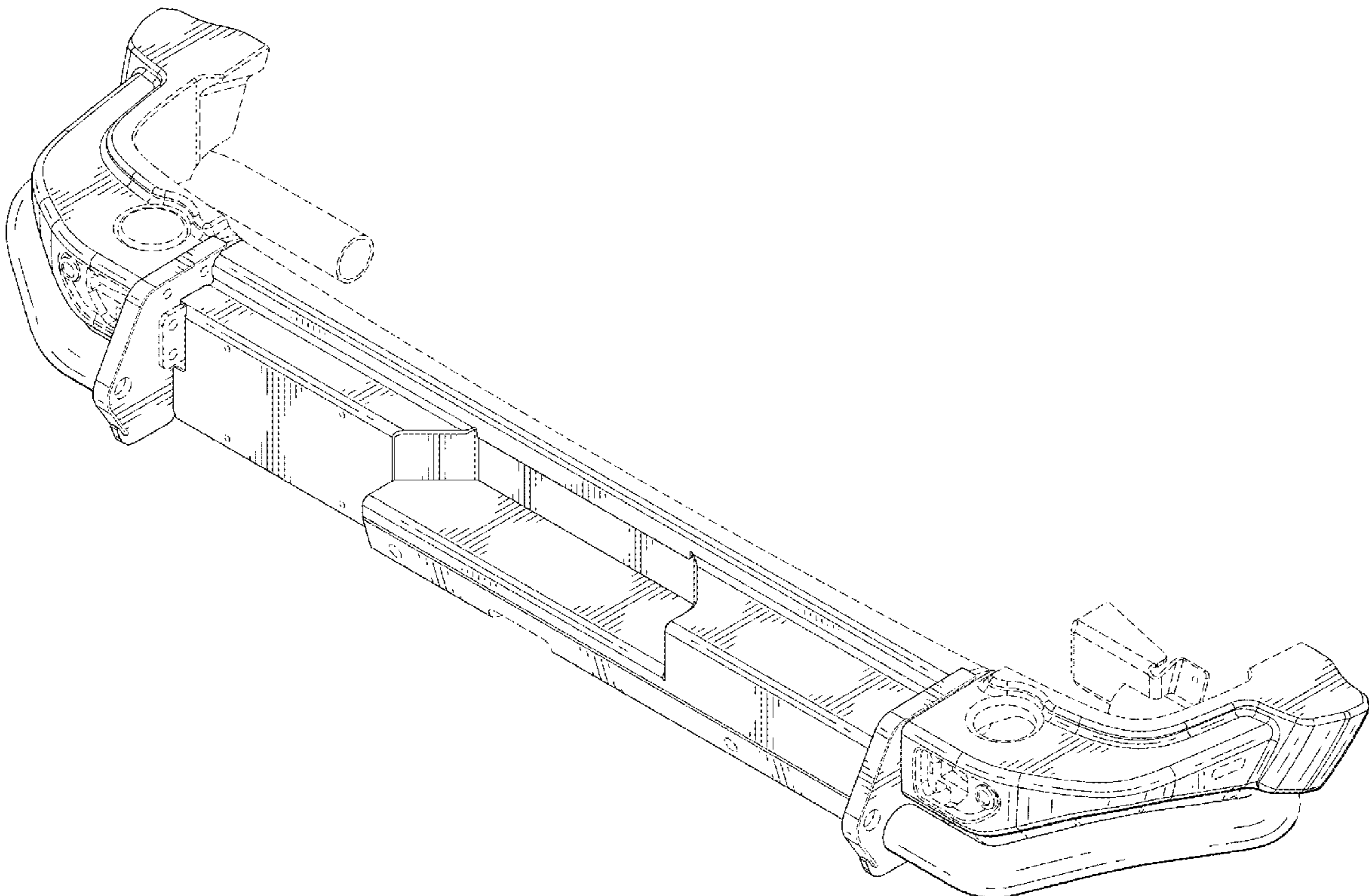

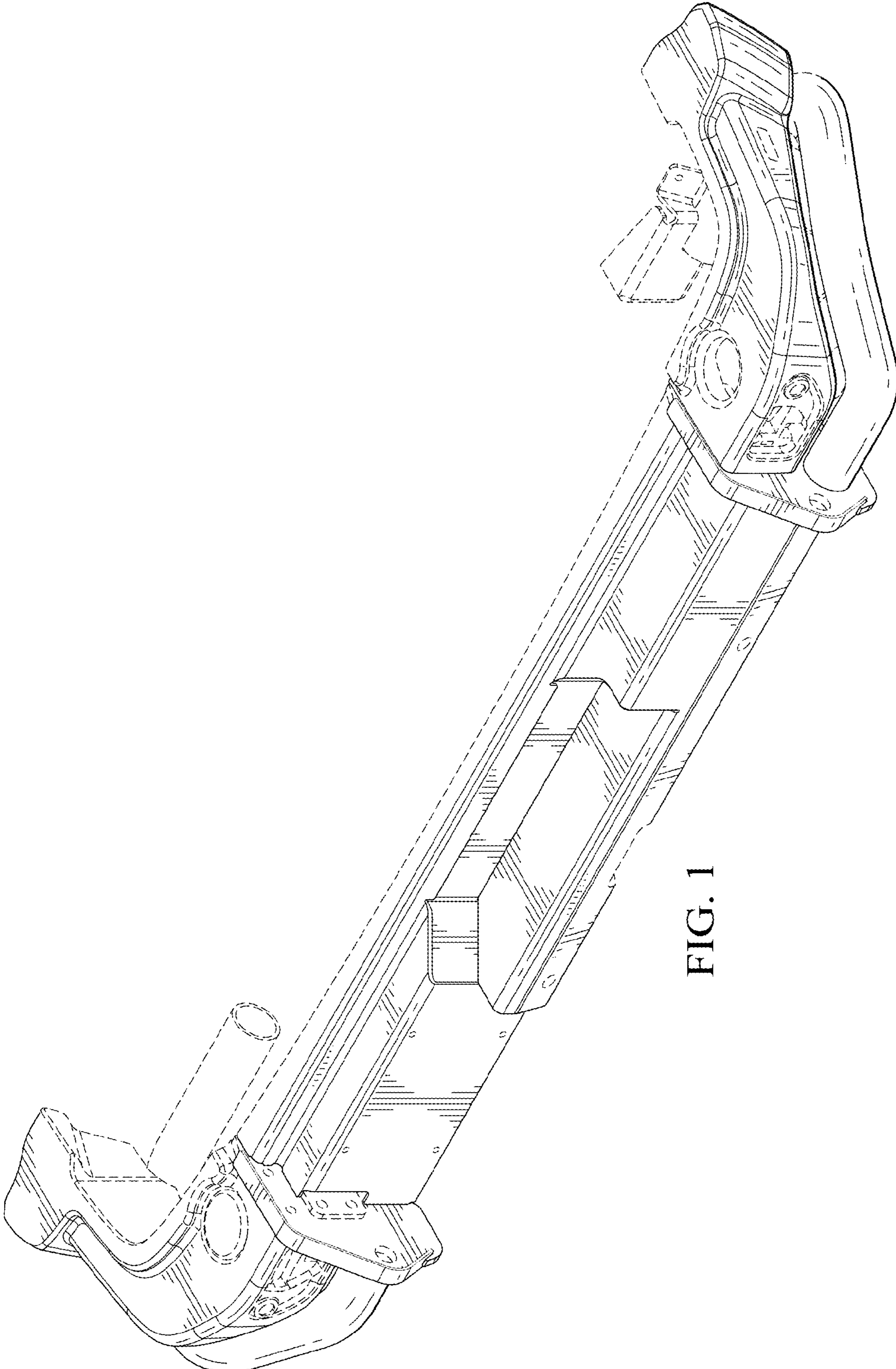

FIG. 1

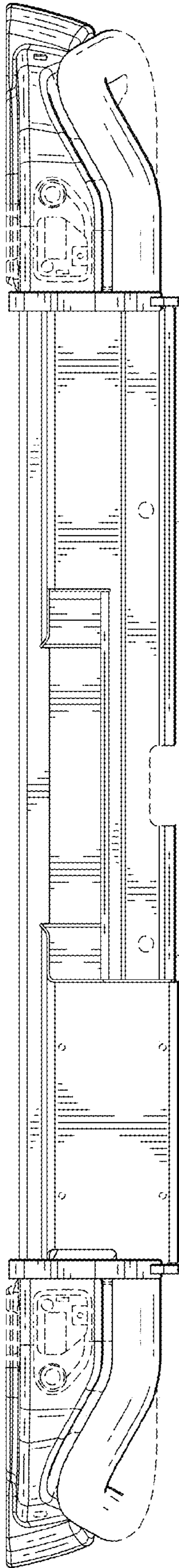

FIG. 2

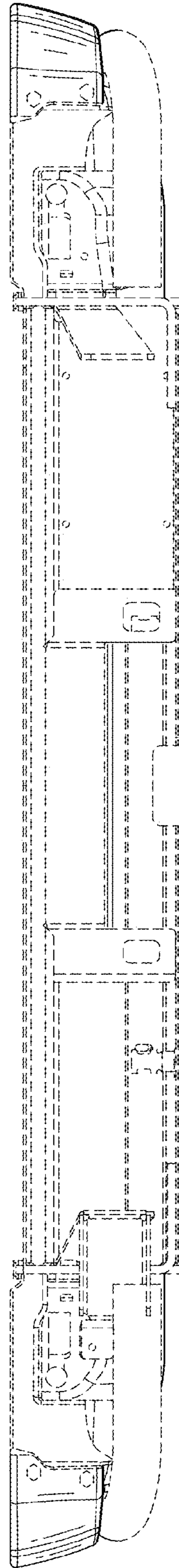

FIG. 3

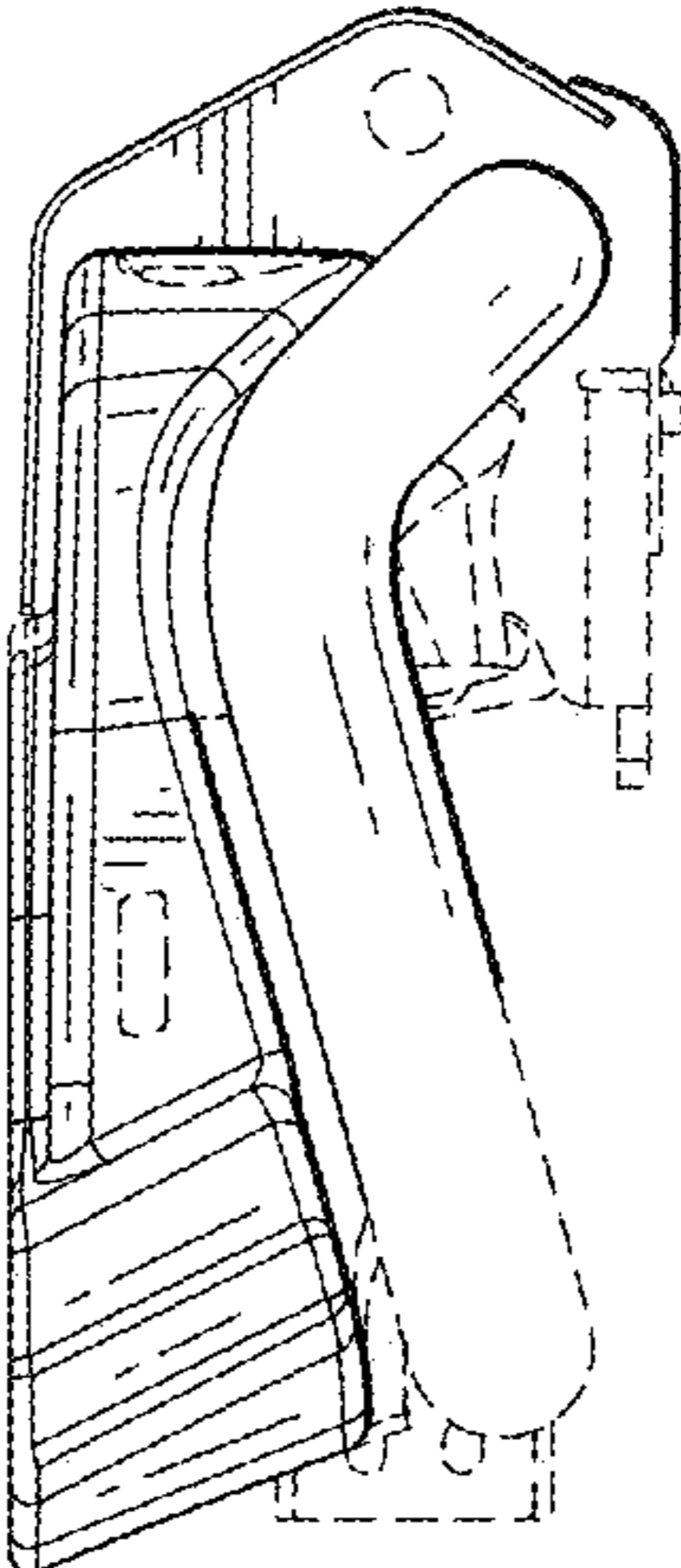

FIG. 5

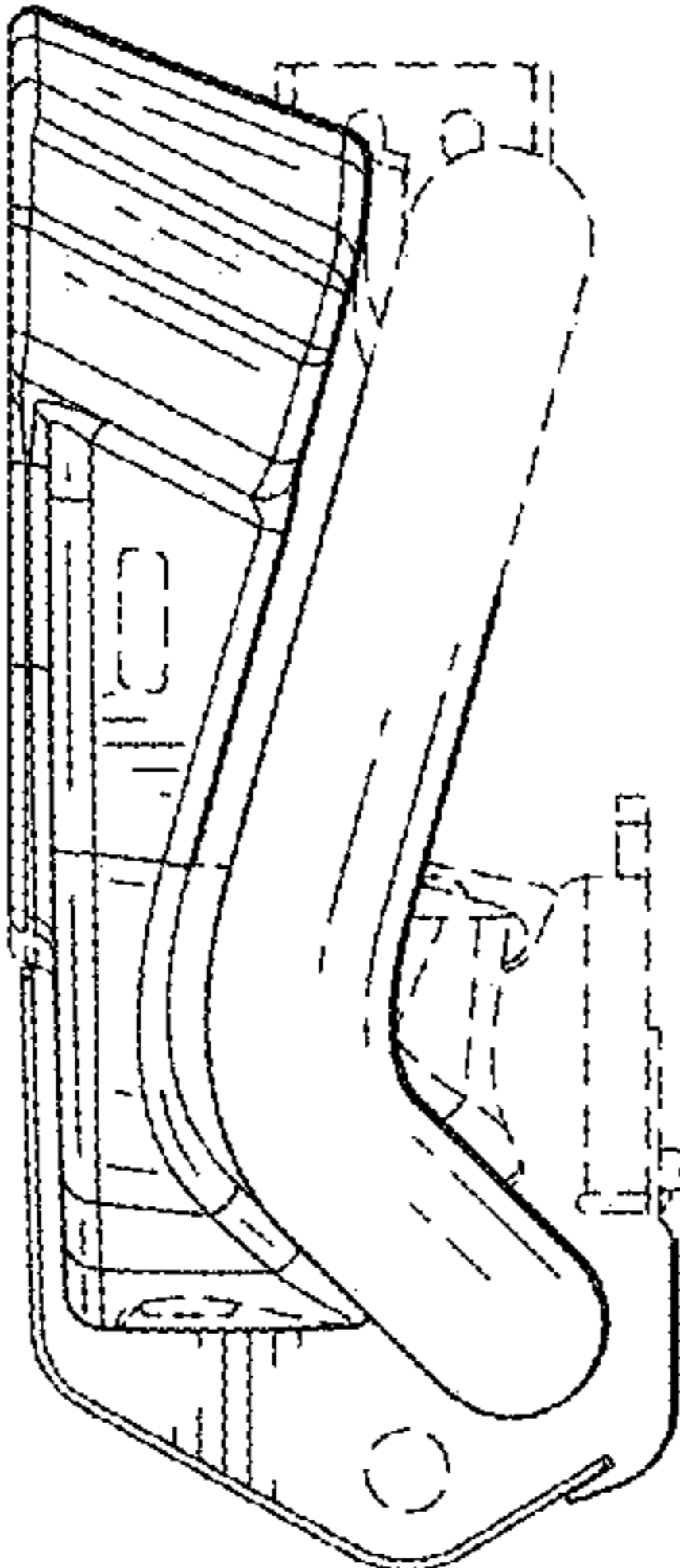

FIG. 4

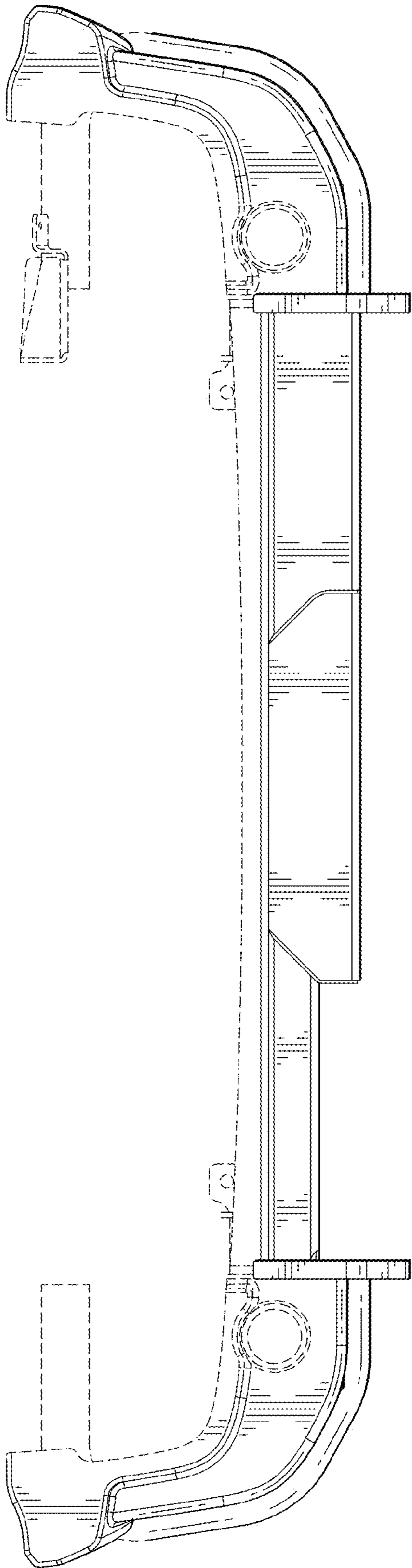

FIG. 6

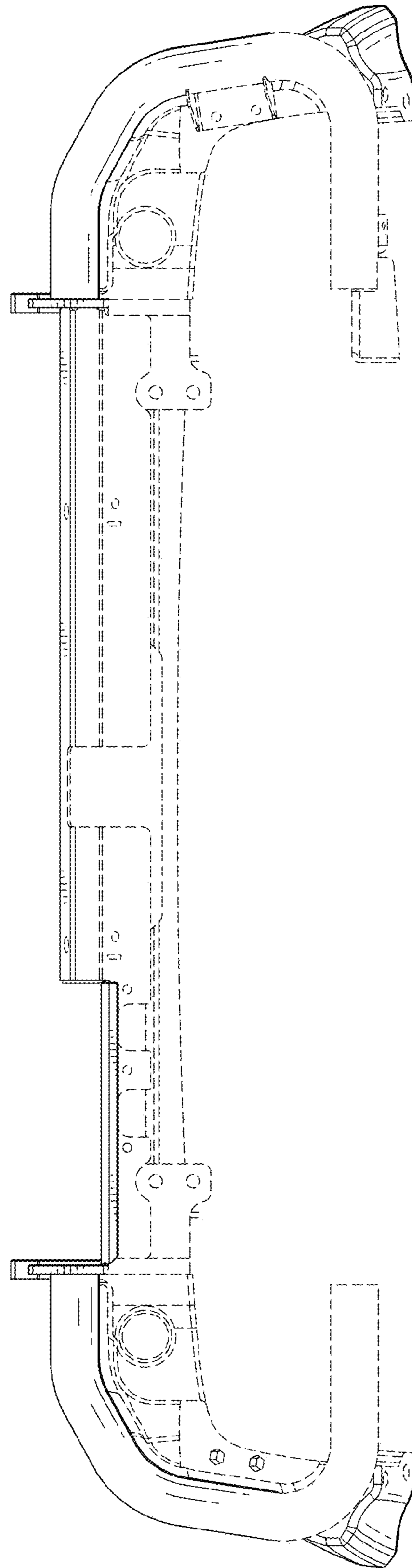

FIG. 7

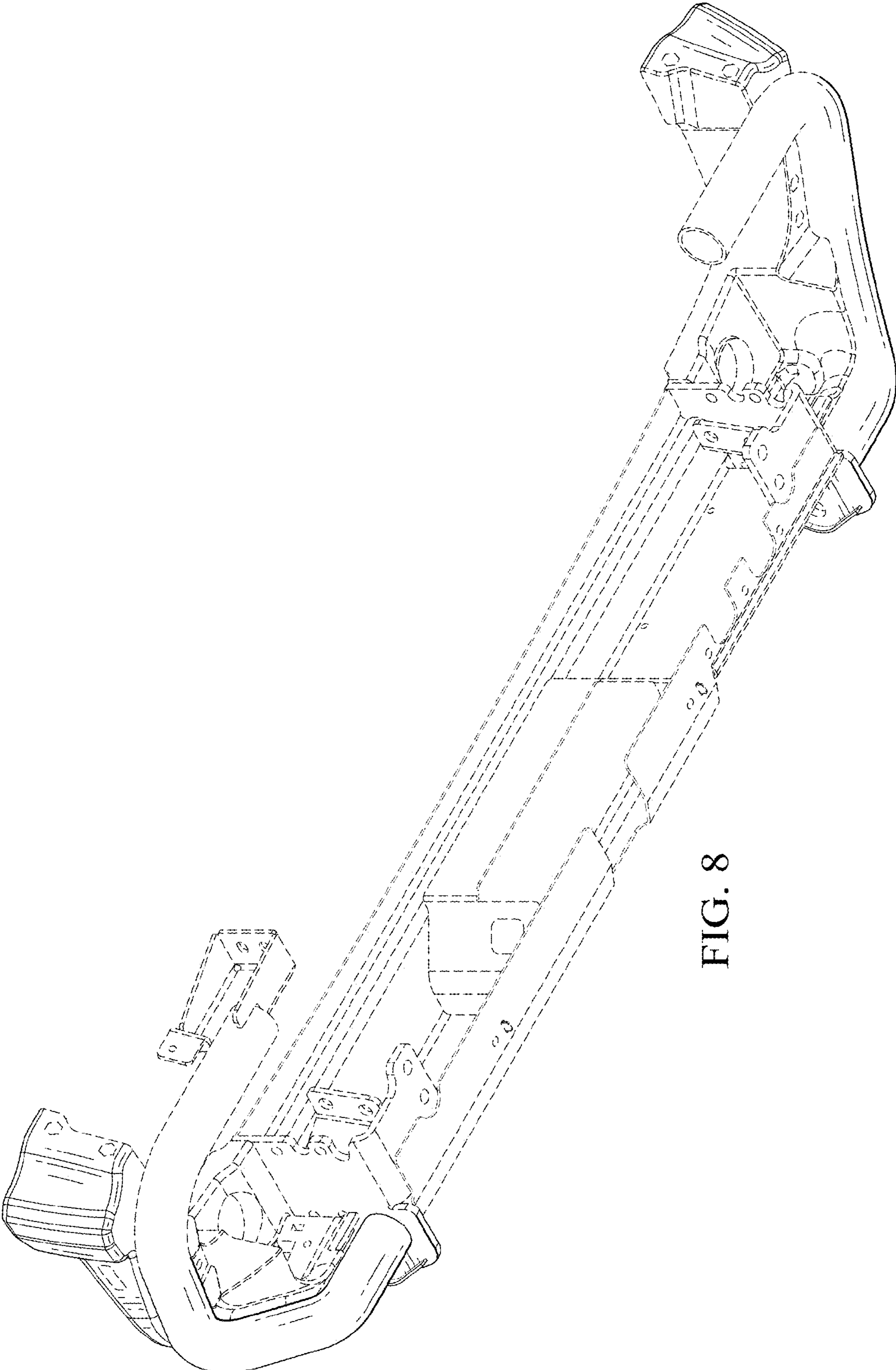

FIG. 8