



US00D886653S

(12) **United States Design Patent**  
**Sugie**

(10) **Patent No.:** **US D886,653 S**  
(45) **Date of Patent:** **\*\* Jun. 9, 2020**

(54) **SAMPLE CHARACTERISTIC MEASURING MACHINE**

(71) Applicant: **SHIMADZU CORPORATION**, Kyoto (JP)

(72) Inventor: **Tomoya Sugie**, Kyoto (JP)

(73) Assignee: **SHIMADZU CORPORATION**, Kyoto (JP)

(\*\*) Term: **15 Years**

(21) Appl. No.: **29/680,891**

(22) Filed: **Feb. 21, 2019**

(30) **Foreign Application Priority Data**

Aug. 31, 2018 (JP) ..... 2018-019093

(51) **LOC (12) Cl.** ..... **10-04**

(52) **U.S. Cl.**  
USPC ..... **D10/81; D24/216**

(58) **Field of Classification Search**

USPC ..... D10/75, 81; D24/216

CPC .. G05F 7/00; G05F 1/52; G01N 27/62; G01N

27/624; H01J 49/04; H01J 49/26; H01J

49/425; H01J 49/061; H01J 49/0031;

H01J 49/49; H01J 49/062; H01J 49/40;

H01J 49/408; H01J 49/107; H01J

49/0036; H01J 49/4245; H01J 49/004;

H01J 49/0004; H01J 49/405; H01J 49/30;

H01J 49/20; H01J 49/02; H01J 49/0027;

H01J 49/0045; H01J 49/027; H01J

49/421; H01J 49/009; H01J 49/427; H01J

49/424; H01J 49/06; H01J 49/00; H01J

49/34; H01J 49/42; H01J 49/4205; H01J

49/18; H01J 49/022; H01J 49/0022; H01J

49/24; H01J 49/4215; H01J 49/164; H01J

49/4255; H01J 49/0009; G01J 3/00; G01J

3/0202; G01J 3/0205; G01J 3/0208; G01J

3/021; G01J 3/0213; G01J 3/0216; G01J

3/0218; G01J 3/0221; G01J 3/0224; G01J

3/0227; G01J 3/0229; G01J 3/0232; G01J

3/0235; G01J 3/0237; G01J 3/024; G01J

3/0243; G01J 3/0245; G01J 3/0248; G01J

3/0251; G01J 3/0254; G01J 3/0256; G01J

3/0259; G01J 3/0262; G01J 3/0264; G01J  
3/0267; G01J 3/027; G01J 3/0272; G01J  
3/0275; G01J 3/0278; G01J 3/0283; G01J  
3/0286; G01J 3/0289; G01J 3/0291; G01J  
3/0294; G01J 3/0297; G01J 3/04; G01J  
3/06; G01J 3/08; G01J 3/12; G01J  
3/1256; G01J 3/14; G01J 3/16; G01J  
3/18; G01J 3/1804; G01J 3/1809; G01J  
3/1833; G01J 3/1838; G01J 3/189; G01J  
3/1895; G01J 3/20; G01J 3/22; G01J  
3/24; G01J 3/26; G01J 3/28; G01J  
3/2803; G01J 3/2823; G01J 3/2846; G01J  
3/2889; G01J 3/30; G01J 3/32; G01J  
3/36; G01J 3/40;

(Continued)

(56) **References Cited**

U.S. PATENT DOCUMENTS

D356,967 S \* 4/1995 Takekoshi ..... D10/81  
D599,688 S \* 9/2009 Ito ..... D10/81

\* cited by examiner

*Primary Examiner* — Antoine Duval Davis  
(74) *Attorney, Agent, or Firm* — JCIPRNET

(57) **CLAIM**

The ornamental design for a sample characteristic measuring machine, as shown and described.

**DESCRIPTION**

FIG. 1 is a perspective view of a sample characteristic measuring machine showing my new design;

FIG. 2 is a front view thereof;

FIG. 3 is a rear view thereof;

FIG. 4 is a left side view thereof;

FIG. 5 is a right side view thereof;

FIG. 6 is a top view thereof; and,

FIG. 7 is a bottom view thereof.

**1 Claim, 5 Drawing Sheets**

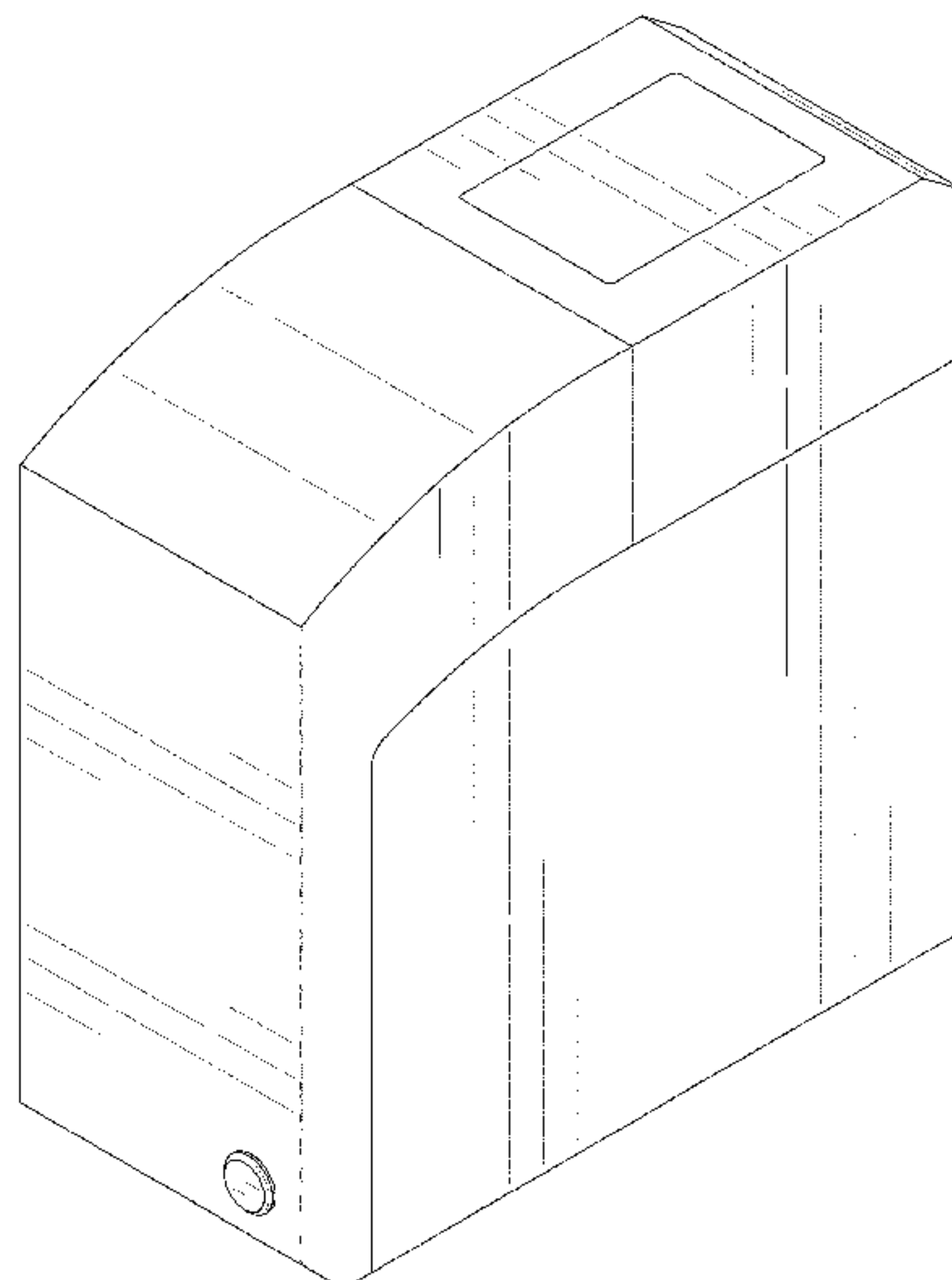

(58) **Field of Classification Search**

CPC .... G01J 3/42; G01J 3/427; G01J 3/433; G01J  
3/4388; G01J 3/44; G01J 3/4406; G01J  
3/4412; G01J 3/443; G01J 3/447; G01J  
3/45; G01J 3/453; G01J 3/4531; G01J  
3/4532; G01J 3/4535; G01J 3/4537; G01J  
3/457; G01J 3/46; G01J 3/461; G01J  
3/462; G01J 3/463; G01J 3/465; G01J  
3/50; G01J 3/501; G01J 3/502; G01J  
3/504; G01J 3/505; G01J 3/506; G01J  
3/508; G01J 3/51; G01J 3/513; G01J  
3/52; G01J 3/522; G01J 3/524; G01J  
3/526; G01J 3/528; G01J 2003/0281;  
G01J 2003/042; G01J 2003/045; G01J  
2003/047; G01J 2003/061; G01J  
2003/062; G01J 2003/064; G01J  
2003/065; G01J 2003/066; G01J  
2003/067; G01J 2003/068; G01J  
2003/069; G01J 2003/1204; G01J  
2003/1208; G01J 2003/1213; G01J  
2003/1217; G01J 2003/1221; G01J  
2003/1226; G01J 2003/123; G01J  
2003/1234; G01J 2003/1239; G01J  
2003/1243; G01J 2003/1247; G01J  
2003/1252; G01J 2003/126; G01J  
2003/1265; G01J 2003/1269; G01J  
2003/1273; G01J 2003/1278; G01J  
2003/1282; G01J 2003/1286; G01J  
2003/1291; G01J 2003/1295; G01J  
2003/145; G01J 2003/1814; G01J

2003/1819; G01J 2003/1823; G01J  
2003/1828; G01J 2003/1842; G01J  
2003/1847; G01J 2003/1852; G01J  
2003/1857; G01J 2003/1861; G01J  
2003/1866; G01J 2003/1871; G01J  
2003/1876; G01J 2003/188; G01J  
2003/1885; G01J 2003/262; G01J  
2003/26; G01J 2003/267; G01J  
2003/2806; G01J 2003/2809; G01J  
2003/2813; G01J 2003/2816; G01J  
2003/282; G01J 2003/2826; G01J  
2003/283; G01J 2003/2833; G01J  
2003/2836; G01J 2003/284; G01J  
2003/2843; G01J 2003/285; G01J  
2003/2853; G01J 2003/2856; G01J  
2003/2859; G01J 2003/2863; G01J  
2003/2866; G01J 2003/2869; G01J  
2003/2873; G01J 2003/2876; G01J  
2003/2879; G01J 2003/2883; G01J  
2003/2886; G01J 2003/2893; G01J  
2003/2896; G01J 2003/323; G01J  
2003/326; G01J 2003/421; G01J  
2003/423; G01J 2003/425; G01J  
2003/4275; G01J 2003/4332; G01J  
2003/4334; G01J 2003/4336; G01J  
2003/4418; G01J 2003/4424; G01J  
2003/4435; G01J 2003/451; G01J  
2003/452; G01J 2003/4534; G01J  
2003/4538; G01J 2003/466; G01J  
2003/467; G01J 2003/468; G01J  
2003/503; G01J 2003/507; G01J  
2003/516

See application file for complete search history.

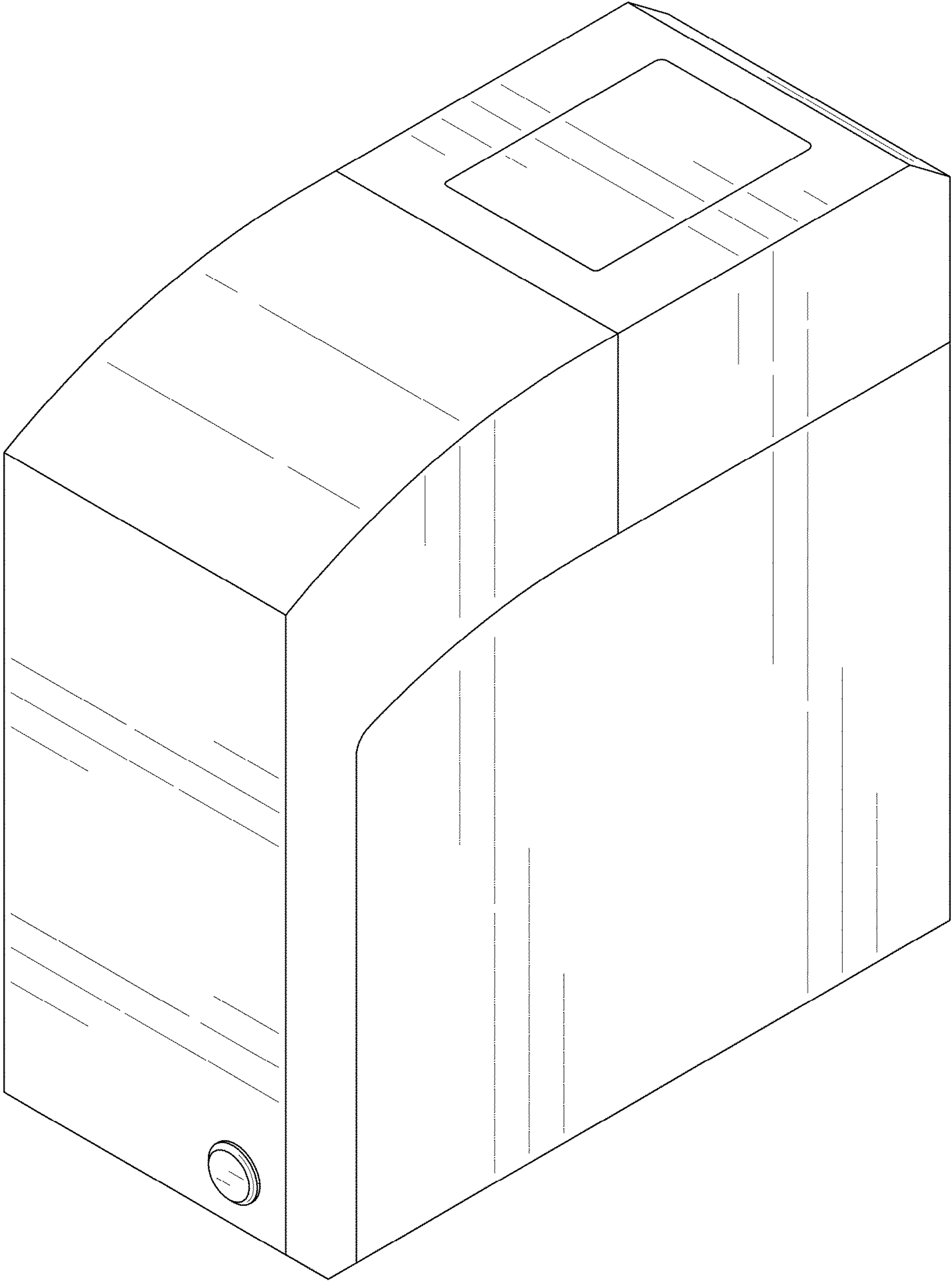

FIG. 1

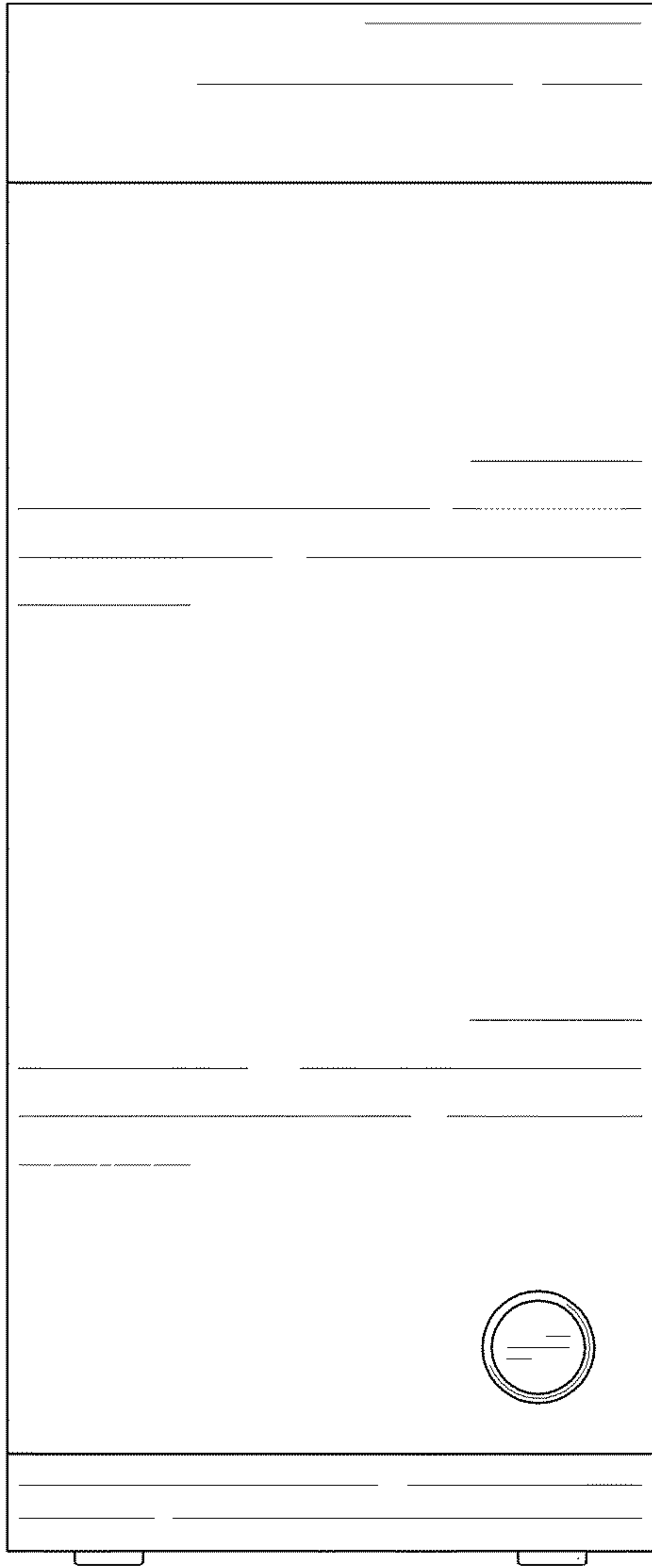

FIG. 2

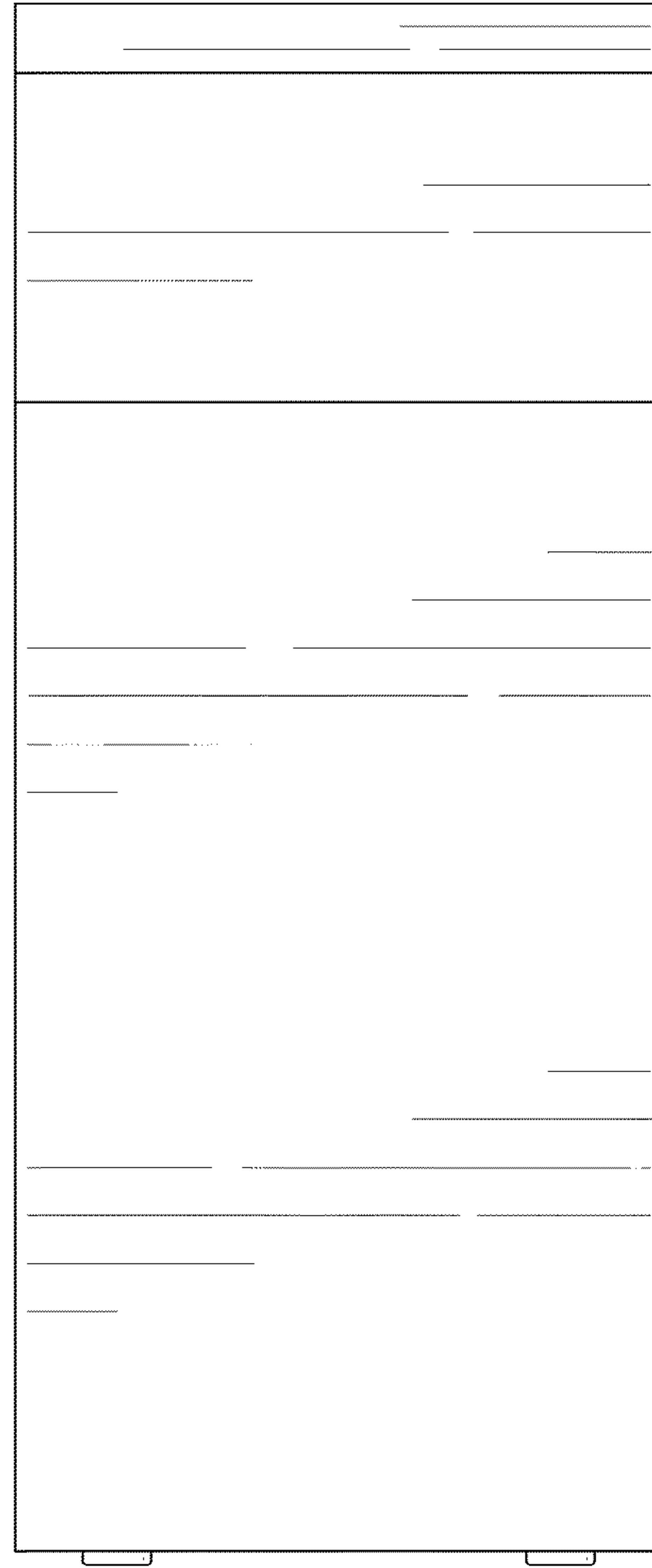

FIG. 3



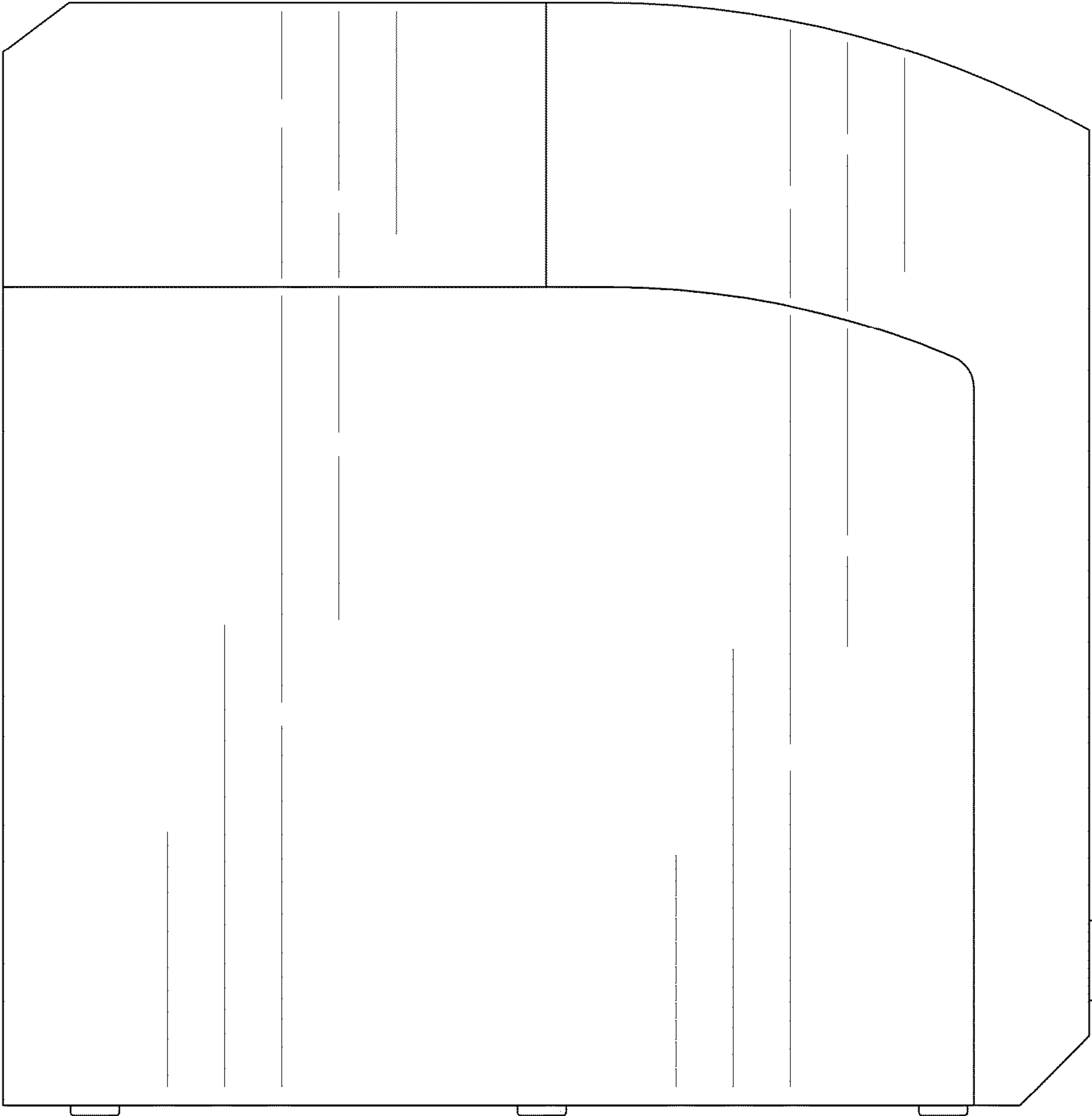

FIG. 4

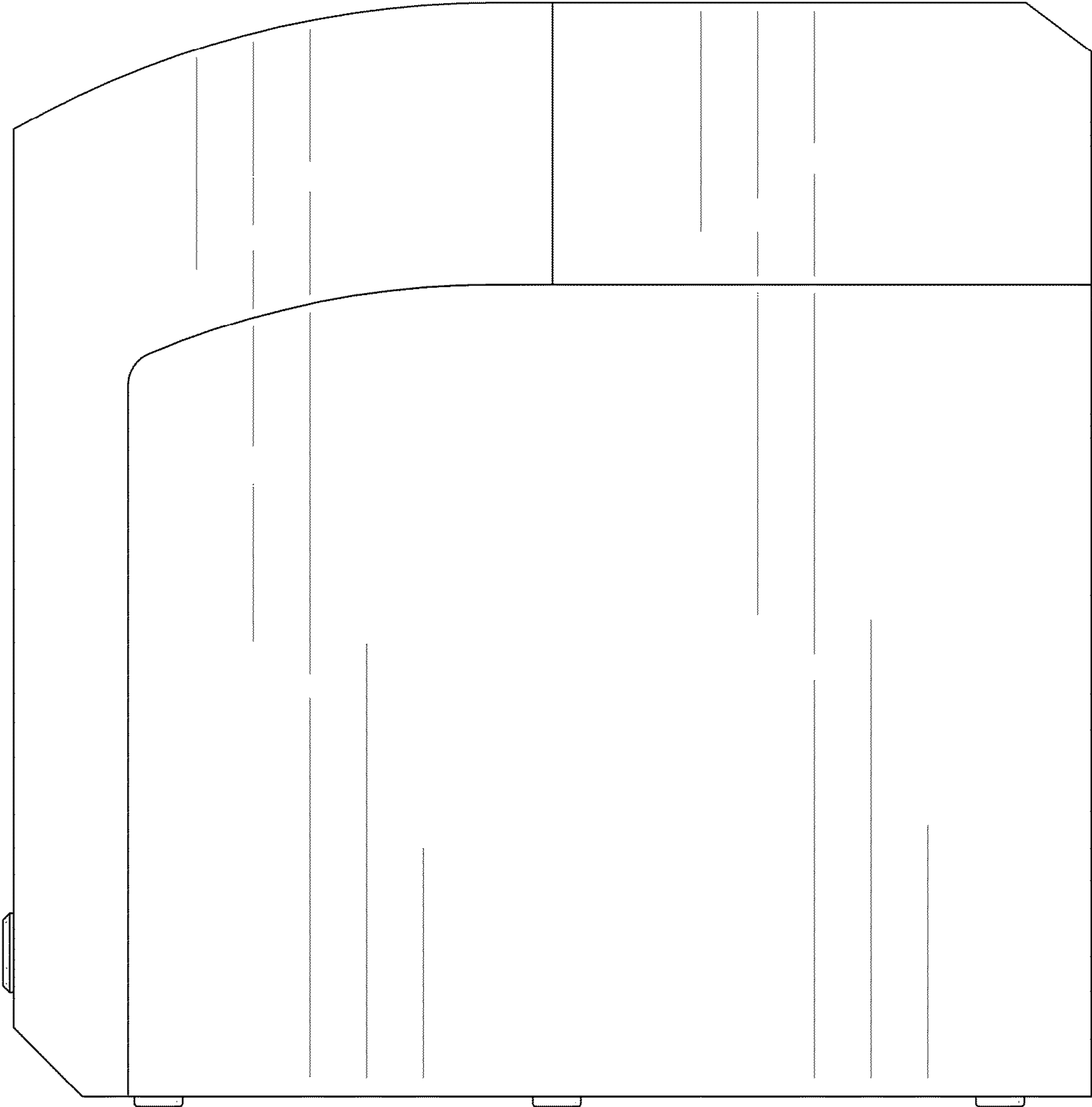

FIG. 5

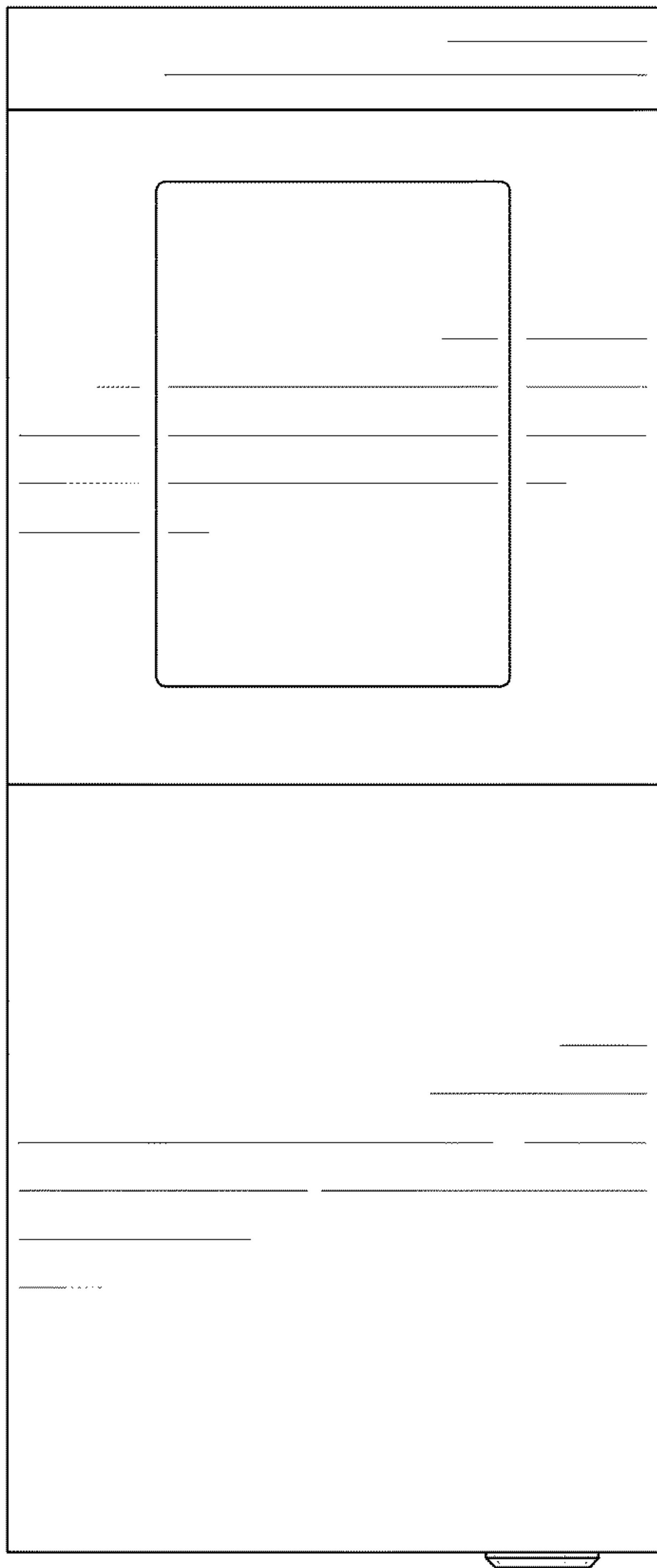

FIG. 6

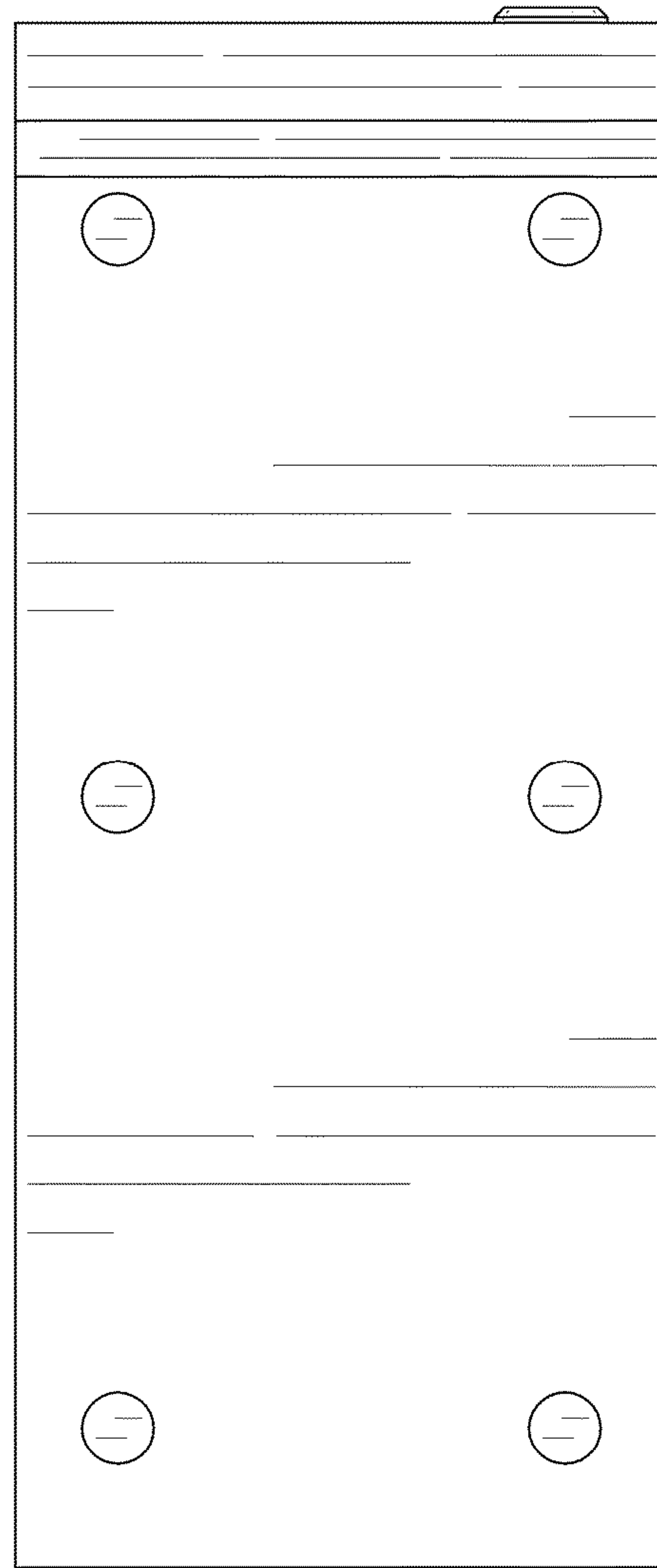

FIG. 7