



US00D886374S

(12) **United States Design Patent**
Hein et al.

(10) **Patent No.:** **US D886,374 S**
(45) **Date of Patent:** **** Jun. 2, 2020**

(54) **ADJUSTABLE ANGLE CURLING IRON**

D536,827 S 2/2007 Chan
7,178,532 B2 2/2007 Kayser
7,730,895 B2 6/2010 Maddocks et al.

(71) Applicant: **CONAIR CORPORATION**, Stamford, CT (US)

(Continued)

(72) Inventors: **Duane Charles Hein**, Monroe, CT (US); **Sergio Lopes Fernandes da Costa**, Danbury, CT (US)

OTHER PUBLICATIONS

INFINITIPRO by Conair Perfect Angle Curling Wand, Conair, reviewed on Aug. 29, 2018 on amazon.com, retrieved on Mar. 25, 2019, retrieved from the Internet URL: <https://www.amazon.com/INFINITIPRO-Perfect-Curling-Adjustable-Positions/dp/B07DKS3TGJ>.*

(73) Assignee: **Conair Corporation**, Stamford, CT (US)

(**) Term: **15 Years**

Primary Examiner — Jennifer Rivard

Assistant Examiner — Alison M Ofstun

(21) Appl. No.: **29/643,454**

(74) *Attorney, Agent, or Firm* — Lawrence Cruz, Esq.;

Ryan, Mason & Lewis, LLP

(22) Filed: **Apr. 9, 2018**

(51) **LOC (12) Cl.** **28-03**

(52) **U.S. Cl.**
USPC **D28/35**

(57) **CLAIM**

The ornamental design for an adjustable angle curling iron, as shown and described.

(58) **Field of Classification Search**
USPC D28/10, 35, 37, 38
CPC ... A45D 1/04; A45D 2/00; A45D 2/02; A45D 4/00; A45D 8/00; A45D 7/02; A45D 8/40; A45D 2001/045; A45D 2001/008; A45D 19/16; A45D 1/00-1; A45D 1/28; A45D 2/001; A45D 2/002; A45D 2/04; A45D 2/06; A45D 2/08; A45D 2/10; A45D 2/12-22; A45D 2/24-34; A45D 2/36-367

DESCRIPTION

FIG. 1 is a perspective view of the adjustable angle curling iron showing our new design;
FIG. 2 is a right side elevation view of the adjustable angle curling iron of FIG. 1;
FIG. 3 is a left side elevation view of the adjustable angle curling iron of FIG. 1;
FIG. 4 is a front elevational view of the adjustable angle curling iron of FIG. 1;
FIG. 5 is a rear elevational view of the adjustable angle curling iron of FIG. 1;
FIG. 6 is a top plan view of the adjustable angle curling iron of FIG. 1;
FIG. 7 is a bottom plan view of the adjustable angle curling iron of FIG. 1; and,
FIG. 8 is a perspective view of the adjustable angle curling iron shown in a position of use.

See application file for complete search history.

(Continued)

(56) **References Cited**

U.S. PATENT DOCUMENTS

2,066,328 A * 1/1937 Cameron A61B 1/227
200/293.1
4,075,458 A 2/1978 Moyer
4,101,757 A 7/1978 Van Dyck et al.
4,210,797 A 7/1980 Tomaro
4,228,343 A 10/1980 Kanner et al.
D511,862 S 11/2005 Chan
D516,747 S 3/2006 Chan

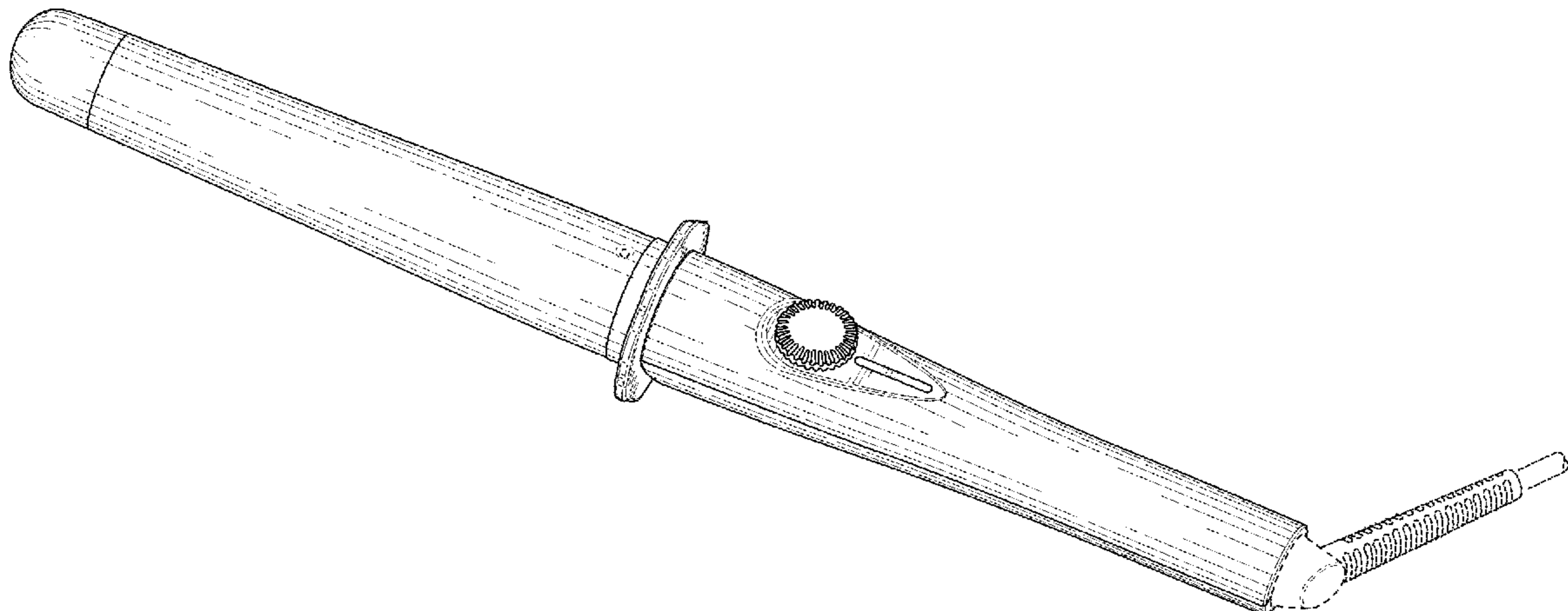

In the drawings the broken lines represent portions of the adjustable angle curling iron which form no part of the claimed design.

1 Claim, 5 Drawing Sheets

(56)

References Cited

U.S. PATENT DOCUMENTS

D646,023 S * 9/2011 Kim D28/35
 D672,501 S * 12/2012 Kim D28/35
 8,353,303 B2 1/2013 Kim
 D698,489 S * 1/2014 Byun D28/35
 D711,042 S 8/2014 Kaizuka
 D713,096 S * 9/2014 Kim D28/35
 D726,963 S * 4/2015 Sayers D28/35
 9,149,101 B2 * 10/2015 Richmond A45D 7/02

D765,910 S * 9/2016 Bermudez D28/35
 D767,205 S * 9/2016 Climer D28/35
 9,433,272 B2 9/2016 Moll
 D840,596 S * 2/2019 Kwok D28/35
 D840,597 S * 2/2019 Kwok D28/35
 D840,598 S * 2/2019 Kwok D28/35
 2004/0237990 A1 12/2004 Choi
 2007/0272266 A1 11/2007 Rijskamp
 2008/0135537 A1 6/2008 Suber et al.
 2010/0089413 A1 4/2010 Wright et al.
 2010/0263223 A1 * 10/2010 Wynne A45D 20/12
 34/97
 2011/0061673 A1 3/2011 Yahnker et al.
 2011/0180096 A1 7/2011 Palermo et al.
 2011/0203606 A1 8/2011 Recchion et al.
 2013/0220360 A1 8/2013 Sharon
 2014/0216493 A1 * 8/2014 Hadden A45D 2/001
 132/223
 2016/0302547 A1 10/2016 Jones

* cited by examiner

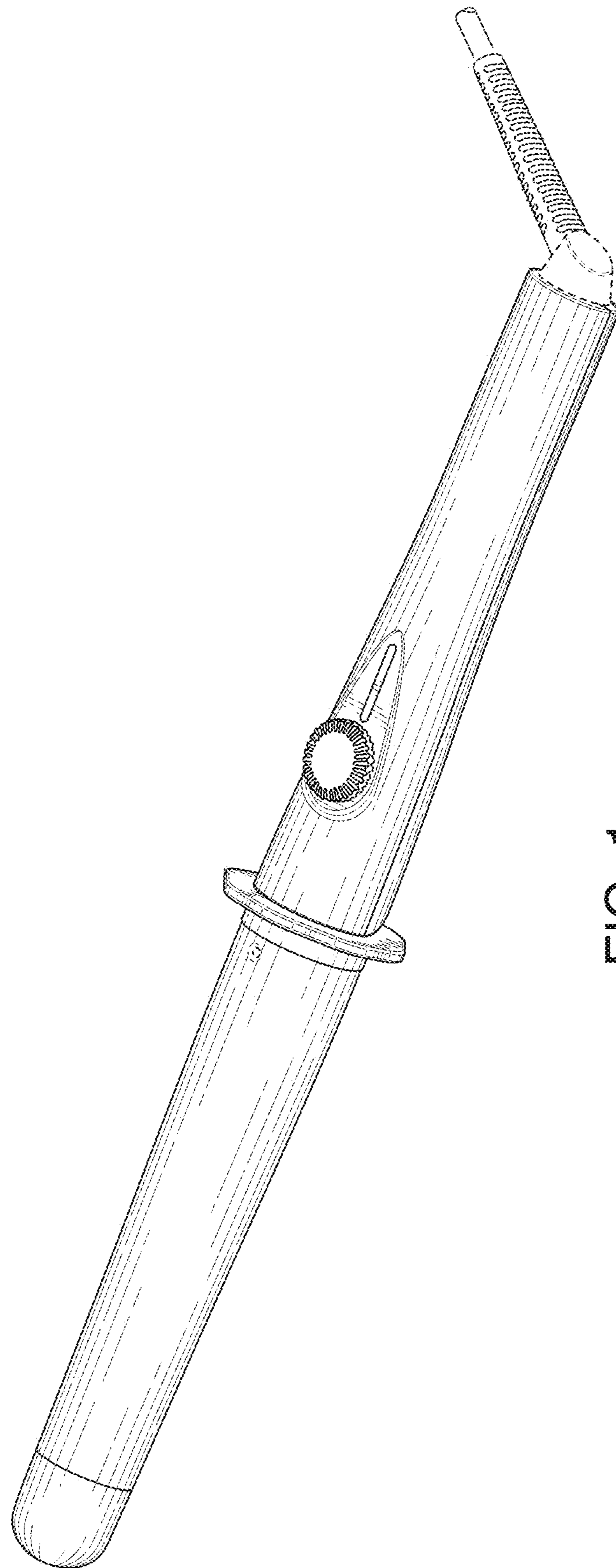

FIG. 1

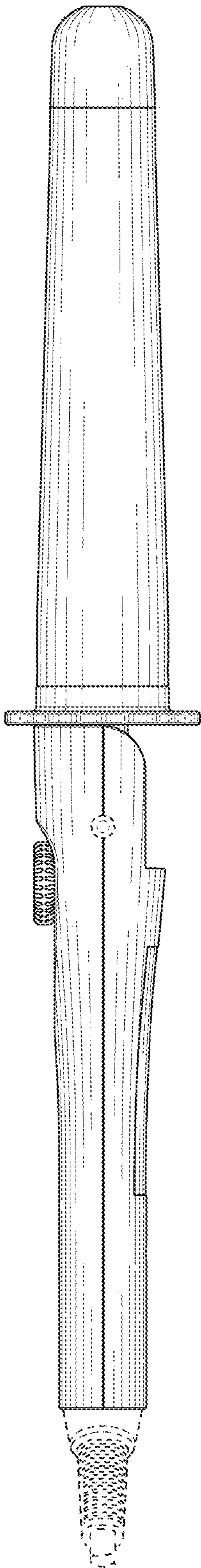

FIG. 2

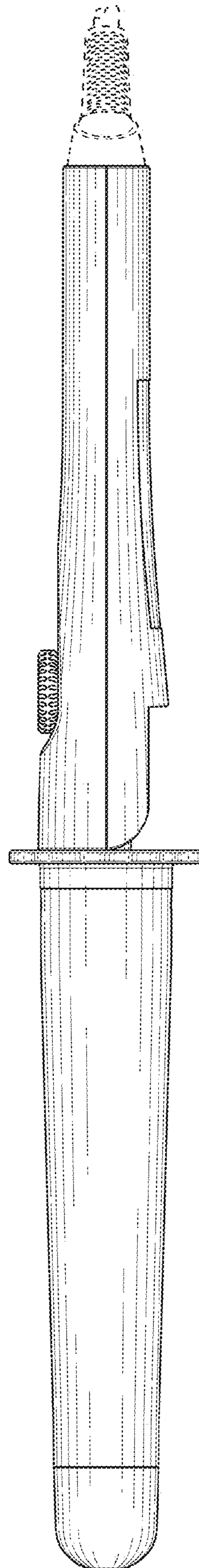

FIG. 3

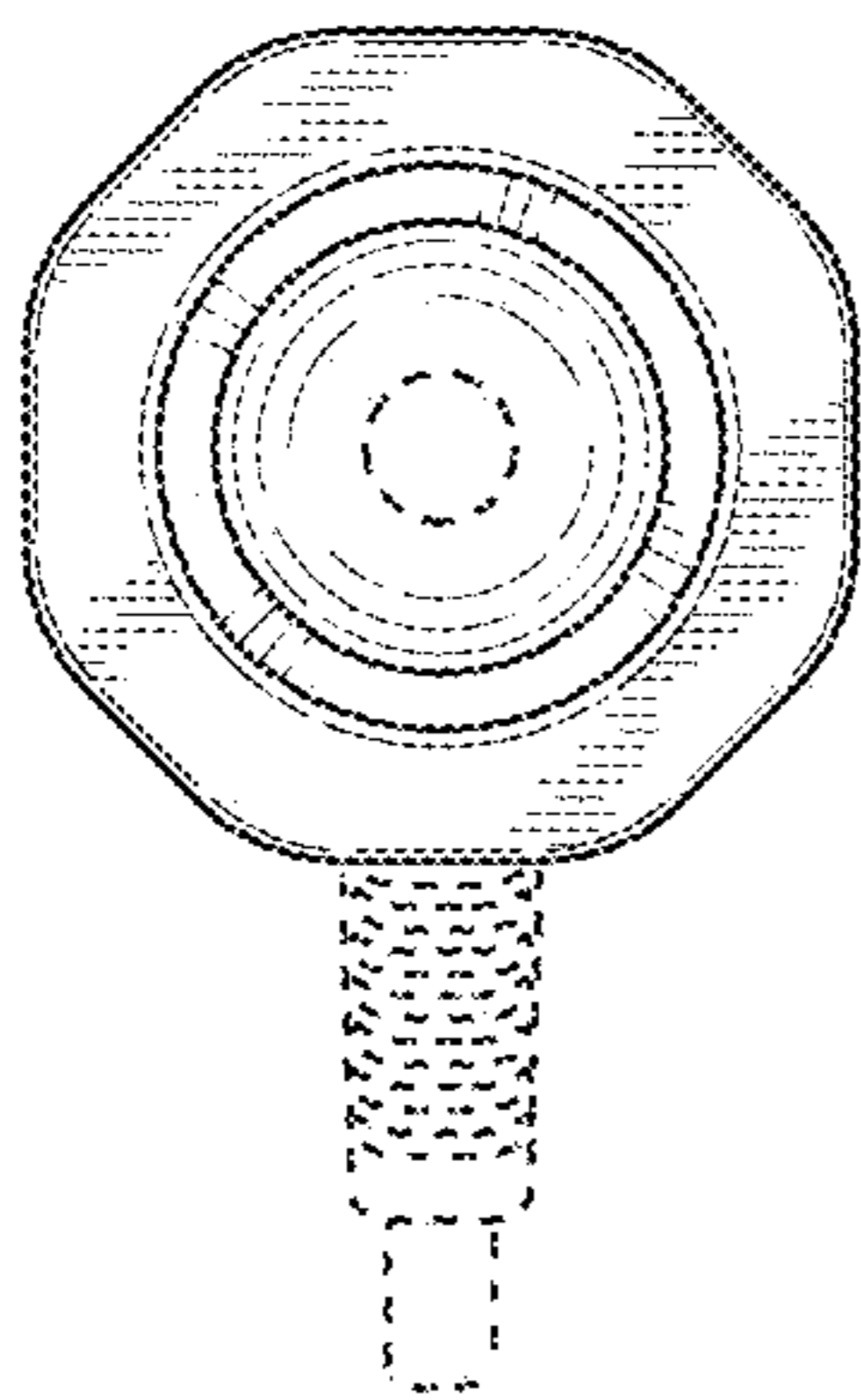

FIG. 4

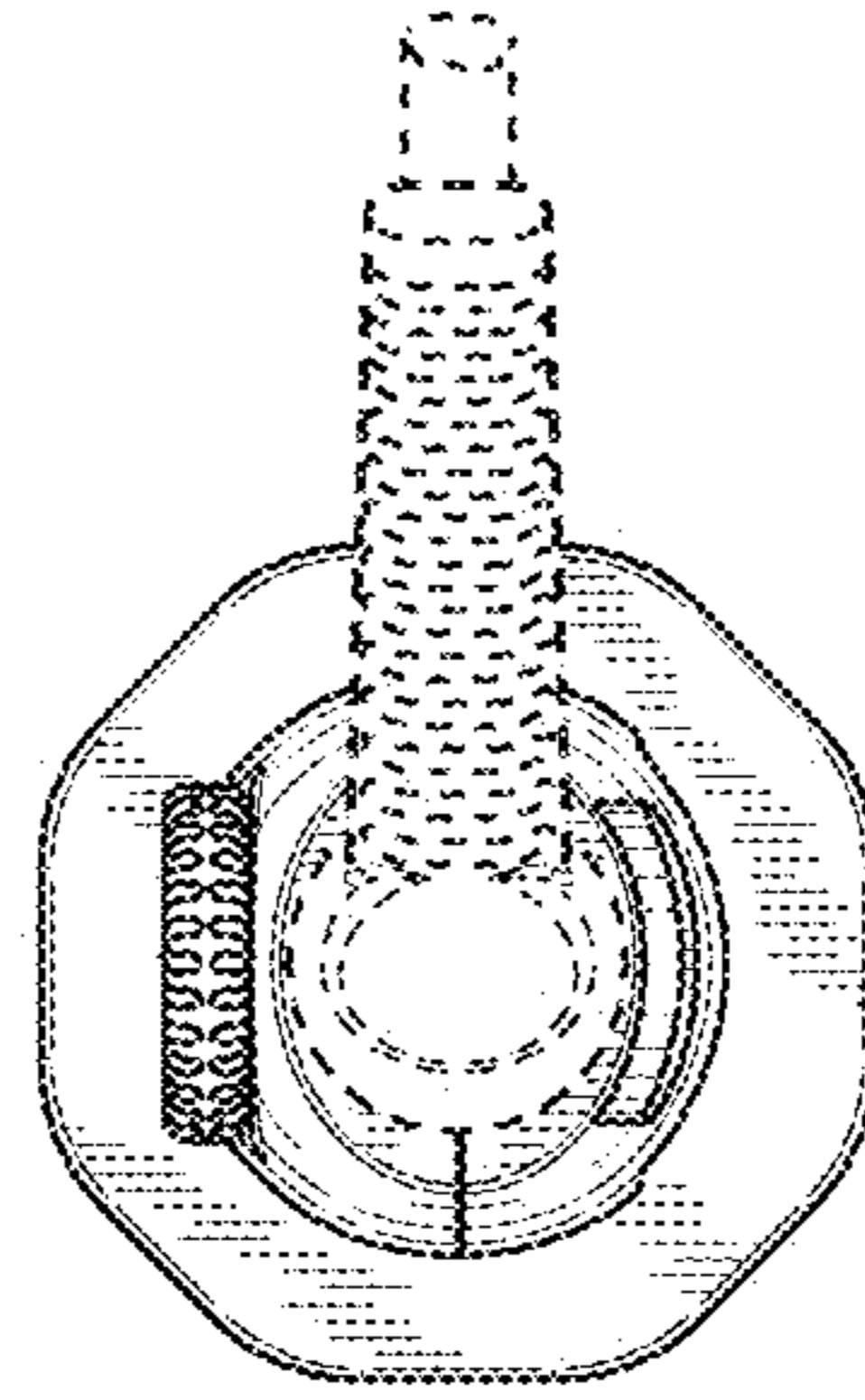

FIG. 5

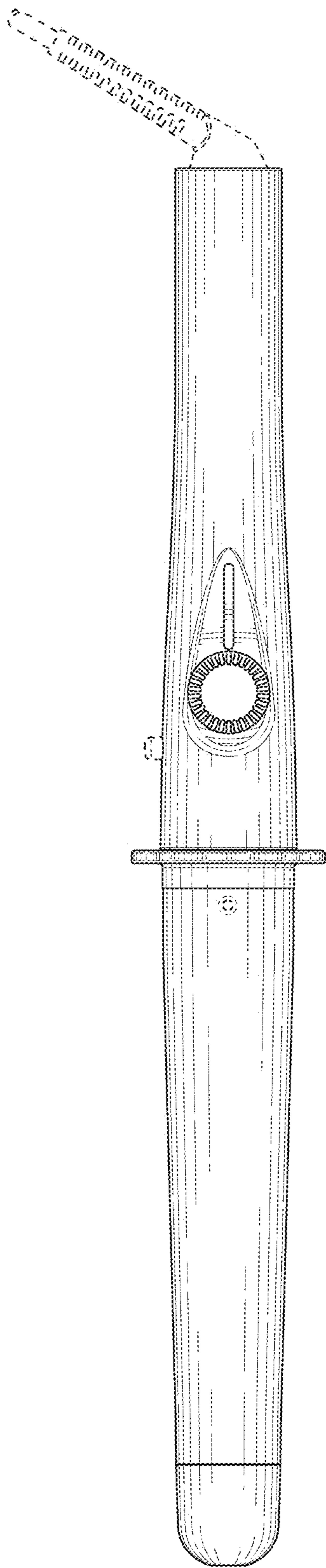

FIG. 6

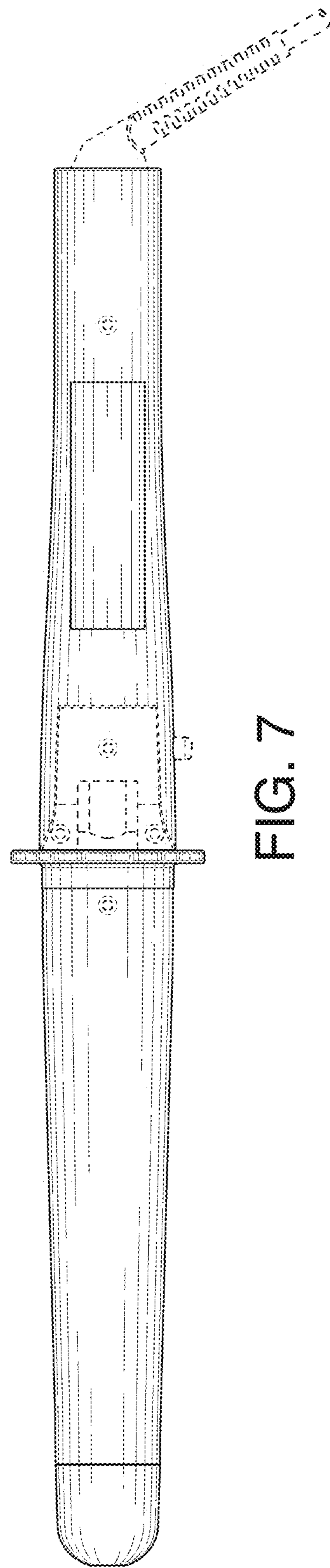

FIG. 7

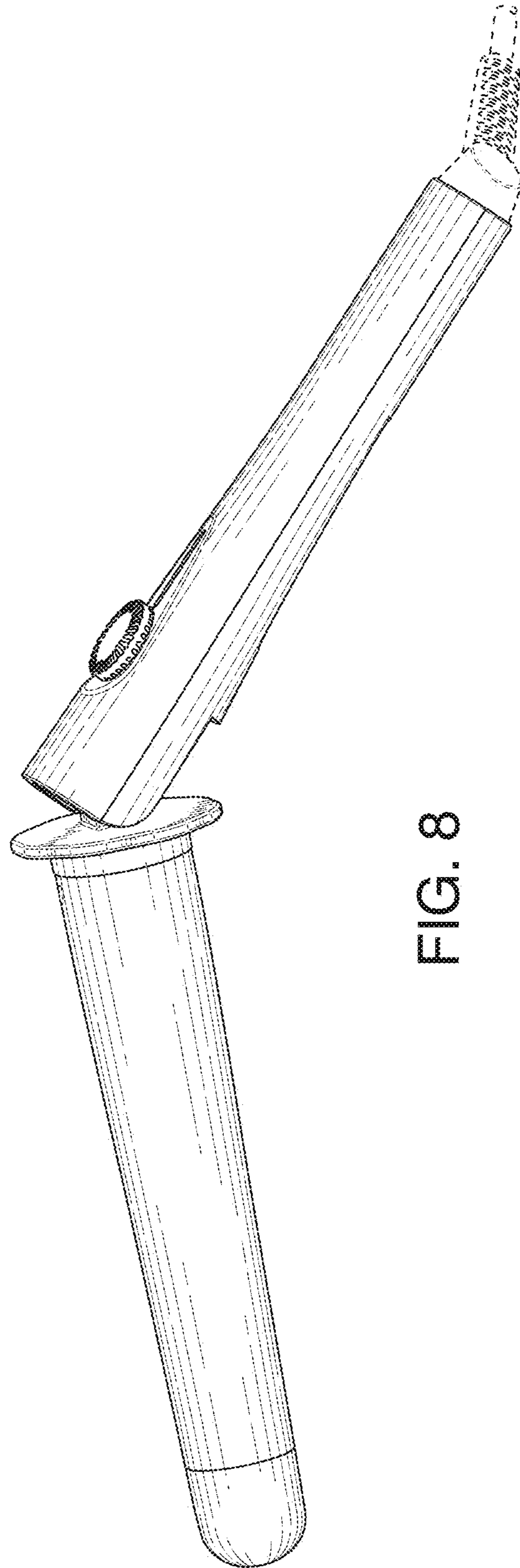

FIG. 8