



US00D886320S

(12) **United States Design Patent**
Bruemmer et al.

(10) **Patent No.:** **US D886,320 S**
(45) **Date of Patent:** **** Jun. 2, 2020**

(54) **FLUID SEQUESTRATION APPARATUS**

- (71) Applicant: **Wavesense, Inc.**, Irvine, CA (US)
- (72) Inventors: **Timothy M. Bruemmer**, Carmel, IN (US); **Bruce D. Irvine**, Concord, CA (US); **Christopher Feistel**, Laguna Beach, CA (US)
- (73) Assignee: **WAVESENSE, INC.**, Irvine, CA (US)
- (**) Term: **15 Years**
- (21) Appl. No.: **29/689,376**
- (22) Filed: **Apr. 29, 2019**
- (51) **LOC (12) Cl.** **24-01**
- (52) **U.S. Cl.**
USPC **D24/216**
- (58) **Field of Classification Search**
USPC D24/107, 121, 122, 129, 186, 216, 223,
D24/224, 231; D10/96, 102, 81
CPC B01L 3/508; B01L 3/5082; B01L 3/5021;
B01L 2300/0832; B03C 2201/18
See application file for complete search history.

(56) **References Cited**

U.S. PATENT DOCUMENTS

D401,697	S *	11/1998	Cloonan	D24/224
D425,618	S *	5/2000	Niermann	D24/122
6,479,302	B1	11/2002	Dremel		
D651,322	S *	12/2011	Svard	D24/224
D839,448	S *	1/2019	Langhoff	D24/224
D870,312	S *	12/2019	Aoki	D24/216
2009/0087903	A1 *	4/2009	Belgrader	B01L 7/525 435/303.1
2011/0287472	A1 *	11/2011	Heinrich	B01L 3/502 435/29
2018/0127741	A1 *	5/2018	Feistel	B01L 3/508

OTHER PUBLICATIONS

Chen, Peng, et al., Inkjet-Print Micromagnet Array on Glass Slides for Immunomagnetic Enrichment of Circulating Tumor Cells, *Annals of Biomedical Engineering*, Aug. 20, 2015, 44 (5): 1710-1720.

Chen, Peng, et al., Microscale Magnetic Field Modulation for Enhanced Capture and Distribution of Rare Circulating Tumor Cells, *Scientific Reports*, Mar. 4, 2015, 5: 8745.

Desitter, I.; et al., A New Device for Rapid Isolation by Size and Characterization of Rare Circulating Tumor Cells, *Anticancer Research*, 2011, 31 (2): 427-442.

Esmaeilsabzail, H, et al., Detection and isolation of circulating tumor cells: principles and methods, *Biotechnol. Adv.*, 2013, 31 (7): 1063-84.

Hoshino, Kazunori, et al., Microchip-based immunomagnetic detection of circulating tumor cells, *Lab on a Chip*, Oct. 2011, 11 (20): 3449-3457.

(Continued)

Primary Examiner — Anhdao Doan
(74) *Attorney, Agent, or Firm* — Stetina Brunda Garred and Brucker

(57) **CLAIM**

The ornamental design for a fluid sequestration apparatus, as shown and described.

DESCRIPTION

FIG. 1 is an elevated perspective view showing our new design with an interconnected fluid reservoir and positioned to co-axially engage with a magnetic housing wherein the fluid reservoir and magnetic housing are disclosed in broken lines to illustrate an environment;

FIG. 2 is an elevated perspective view thereof;

FIG. 3 is a front view thereof

FIG. 4 is a left side view thereof;

FIG. 5 is a top view thereof; and,

FIG. 6 is a bottom view thereof.

1 Claim, 3 Drawing Sheets

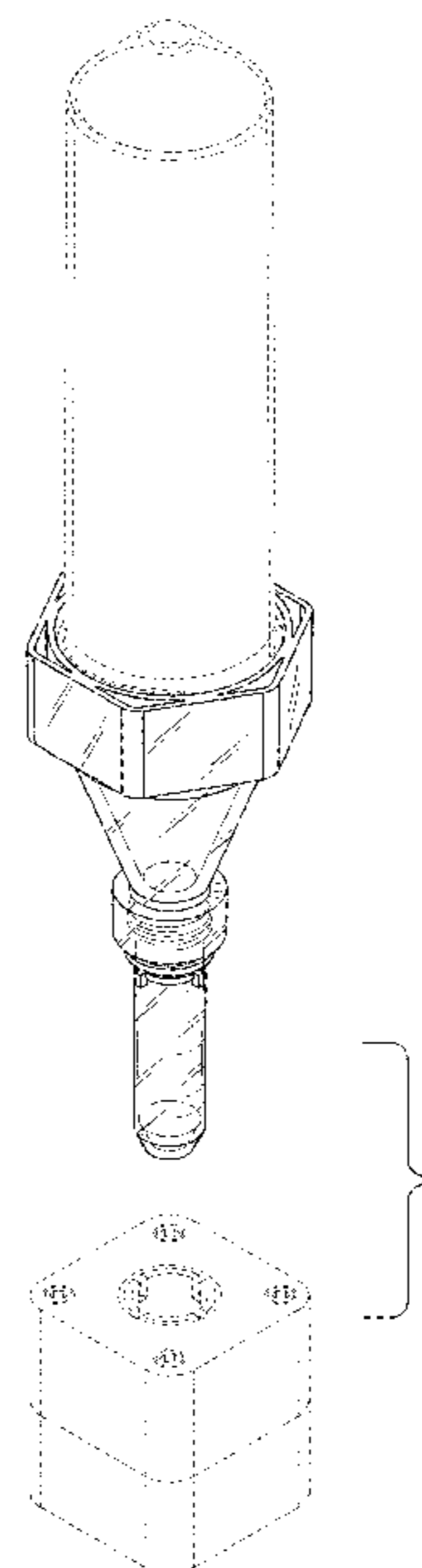

(56)

References Cited

OTHER PUBLICATIONS

Hoshino, Kazunori, et al., Computational Analysis of Microfluidic Immunomagnetic Rare Cell Separation from a Particulate Blood Flow, *Analytical Chemistry*, May 15, 2012, 84 (10): 4292-4299.

Huang, Yu-Yen, et al., Screening and Molecular Analysis of Single Circulating Tumor Cells Using Micromagnet Array, *Scientific Reports*, Nov. 5, 2015, 5: 16047.

Huang, Yu-yen, et al., Immunomagnetic nanoscreening of circulating tumor cells with a motion controlled microfluidic system, *Biomedical Microdevices*, Oct. 30, 2012, 15 (4): 673-681.

Paterlini-Brechot, P, et al., Circulating tumor cells (CTC) detection: Clinical impact and future directions, *Cancer Lett.*, 2007, 253 (2): 180-204.

Peng, Chen, et al., Multiscale immunomagnetic enrichment of circulating tumor cells: from tubes to microchips, *Lab on a Chip*, 2014, 14: 446-458.

Saucedo-Zeni, Nadia; et al., A novel method for the in vivo isolation of circulating tumor cells from peripheral blood of cancer patients using a functionalized and structured medical wire, *International Journal of Oncology*, 2012, 41 (4): 1241-1250.

Nagrath, Sunitha, et al., Isolation of rare circulating tumour cells in cancer patients by microchip technology, *Nature*, Dec. 2007, 450 (7173): 1235-1239.

* cited by examiner

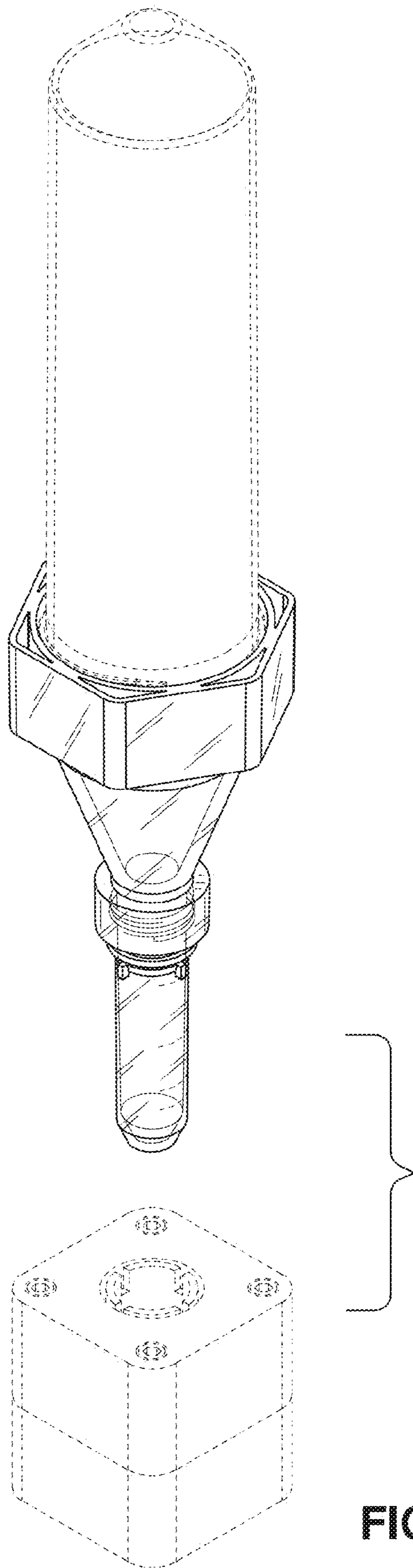

FIG. 1

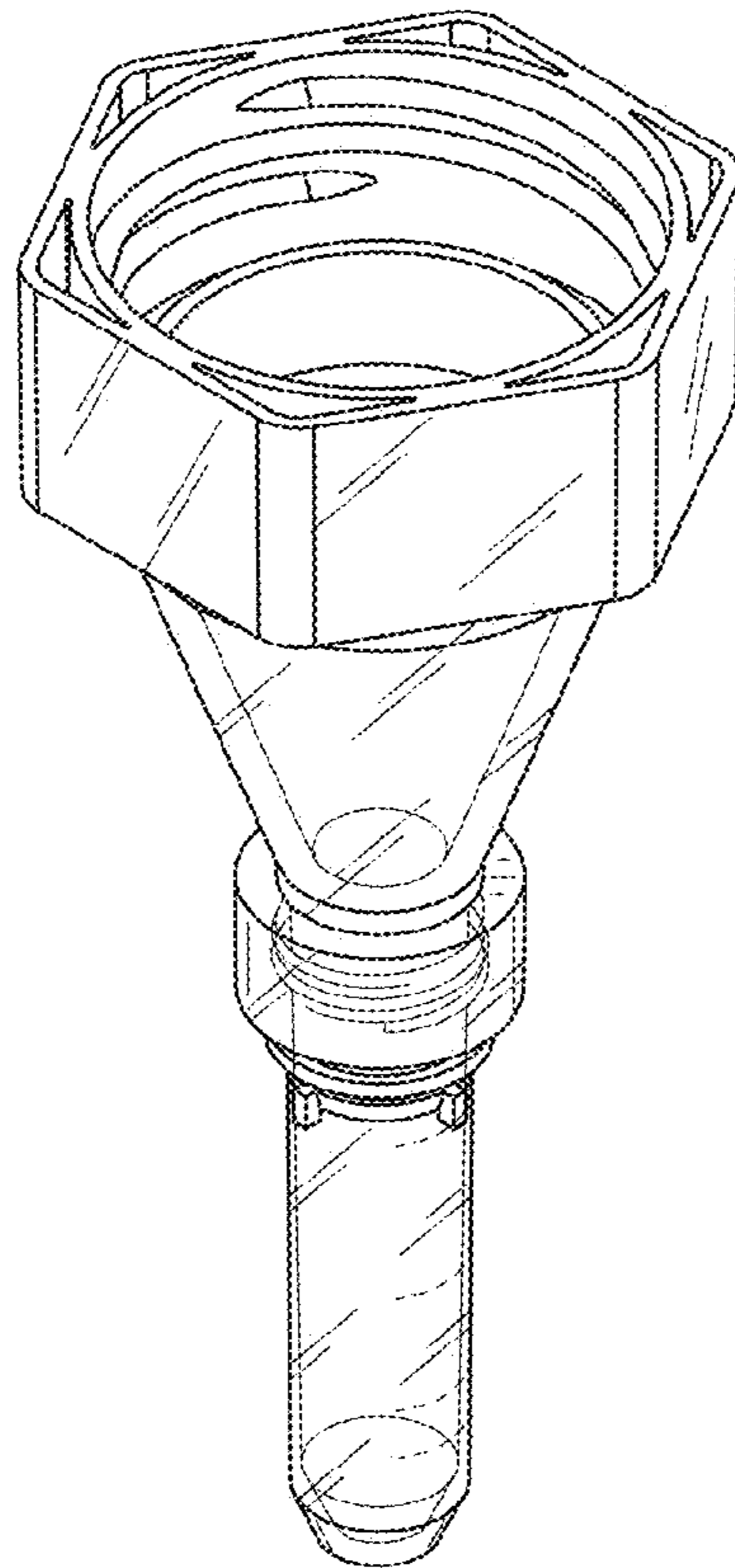

FIG. 2

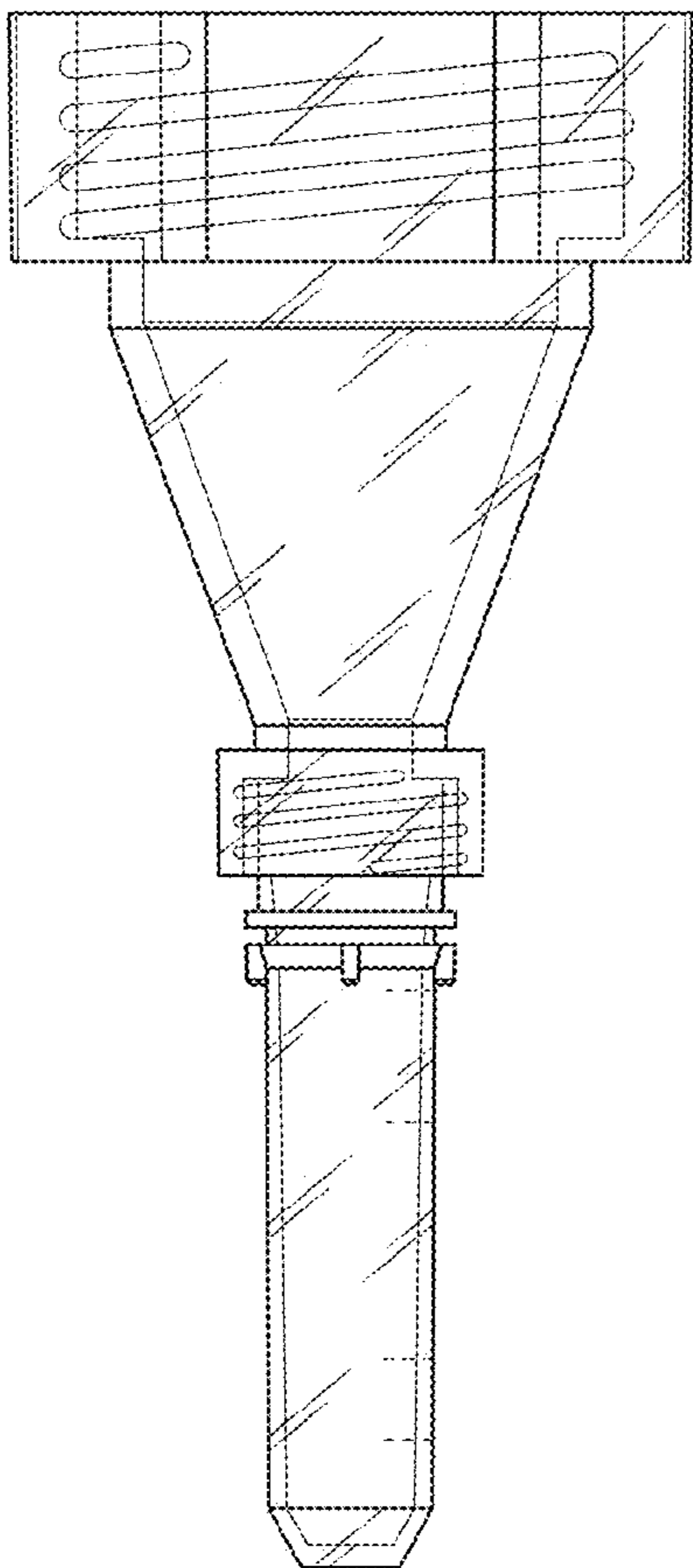

FIG. 3

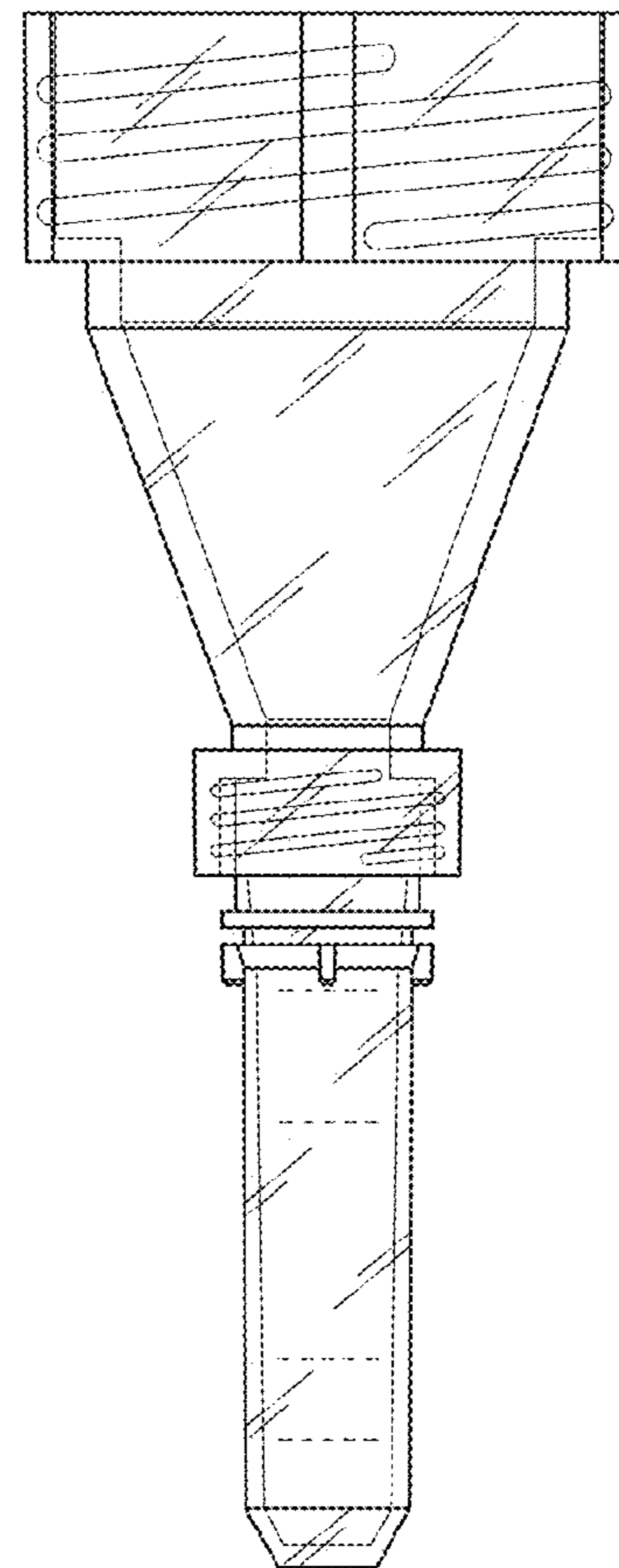

FIG. 4

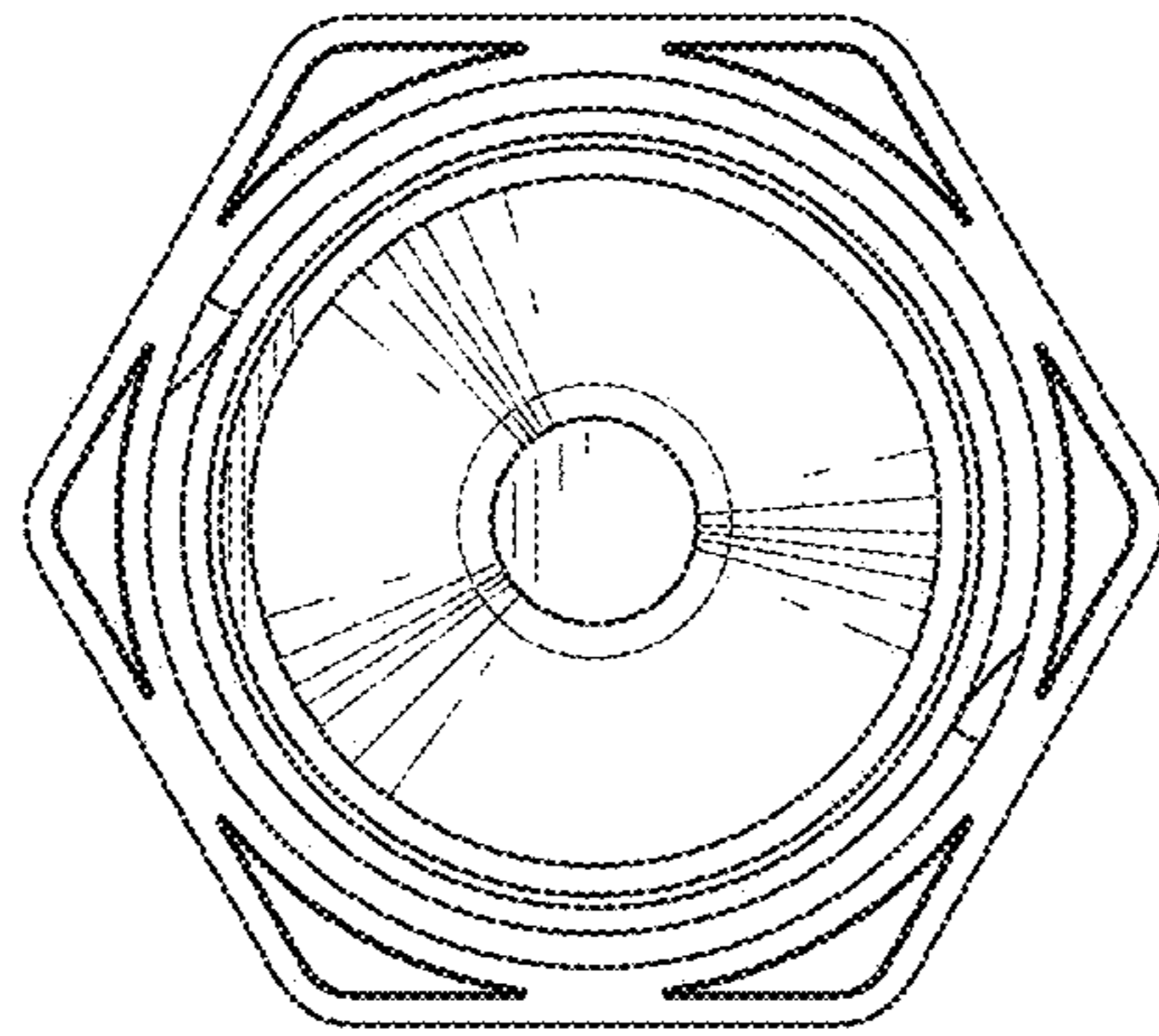

FIG. 5

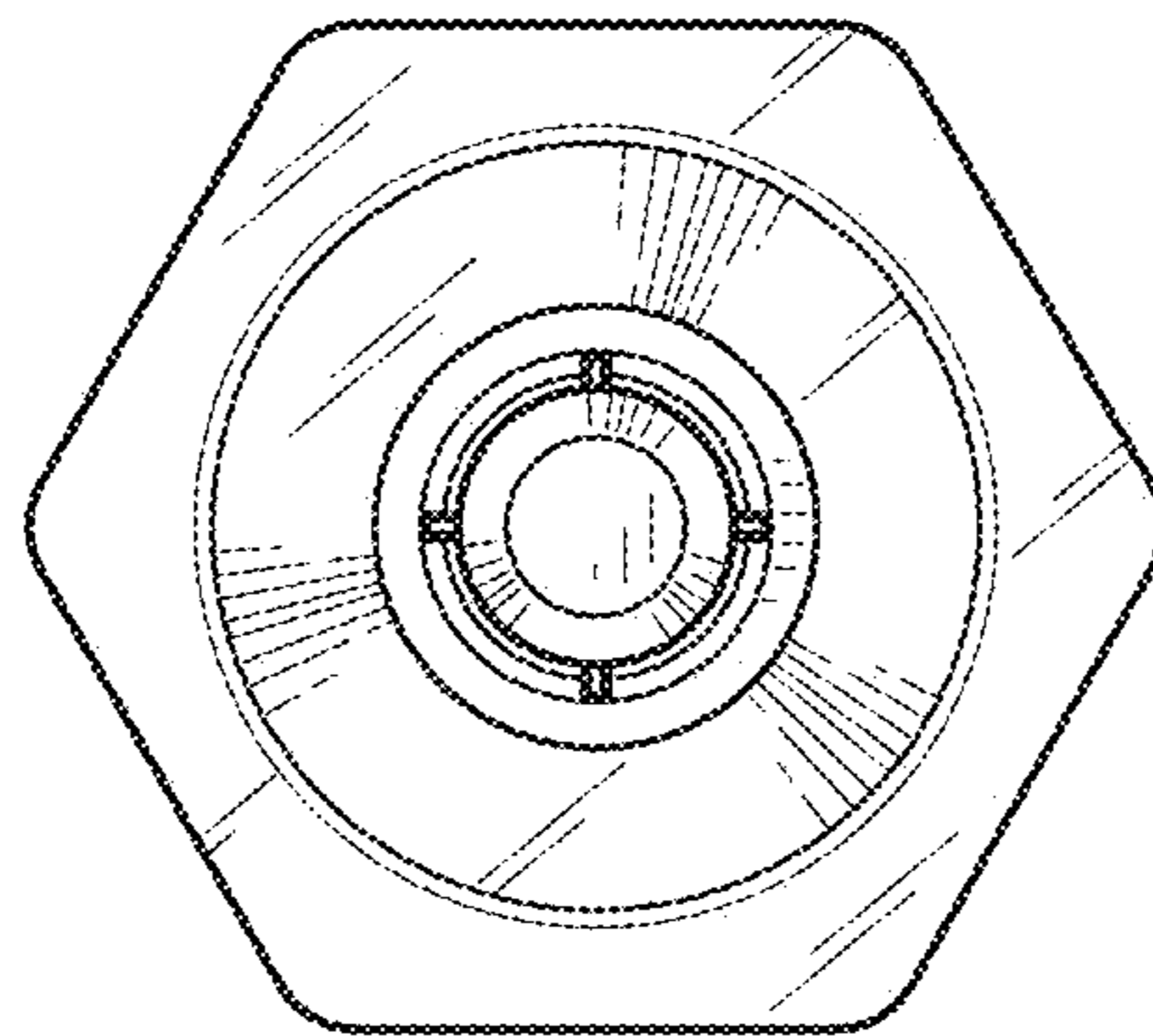

FIG. 6