



US00D885979S

(12) **United States Design Patent**
Steininger

(10) **Patent No.:** **US D885,979 S**
(45) **Date of Patent:** **** Jun. 2, 2020**

(54) **THIRD RAIL SUPPORT**

FOREIGN PATENT DOCUMENTS

(71) Applicant: **Richard Steininger**, North Jackson, OH
(US)

DE 20 2012 101 576 U1 9/2013

(72) Inventor: **Richard Steininger**, North Jackson, OH
(US)

OTHER PUBLICATIONS

(**) Term: **15 Years**

www.conductix.com, "Transit Power Rail for Third Rail and APM Systems", Conductix-Wampfler, 2017, 16 pages.
http://www.lbfoster.com, "Transit Products", 2017, 7 pages.

(21) Appl. No.: **29/643,638**

* cited by examiner

(22) Filed: **Apr. 10, 2018**

Primary Examiner — Ania Aman

(51) **LOC (12) Cl.** **12-03**

(74) *Attorney, Agent, or Firm* — Fay Sharpe LLP

(52) **U.S. Cl.**
USPC **D12/51**

(58) **Field of Classification Search**
USPC D12/36-51
CPC B61F 5/38; B61F 5/52; B61G 9/06; B61G 9/10; B61G 9/22; B61G 9/20; B60M 1/307

See application file for complete search history.

(57) **CLAIM**

The ornamental design for a third rail support, as shown and described.

(56) **References Cited**

U.S. PATENT DOCUMENTS

917,501	A *	4/1909	Steinberger	B60M 1/307
					191/32
928,709	A *	7/1909	Steinberger	B60M 1/307
					191/32
1,532,836	A	4/1925	Schmid et al.		
1,592,077	A *	7/1926	Butler	B60M 1/307
					191/32
1,837,096	A	12/1931	Banks		
2,048,367	A	7/1936	Banks		
2,502,756	A	4/1950	Schmid		
3,071,656	A *	1/1963	Donaldson	B60M 1/307
					191/32
3,475,568	A	10/1969	Dehn		
3,806,672	A	4/1974	Landis		
4,318,462	A	3/1982	Weinhaus		
D616,791	S *	6/2010	Ciloglu	D12/51
7,926,634	B1	4/2011	Morales		
D702,596	S	4/2014	Ciloglu		
D724,490	S	3/2015	Ciloglu et al.		
2017/0320404	A1	11/2017	Steininger		

DESCRIPTION

FIG. 1 is a perspective view of a third rail support showing a first embodiment of my new design;
FIG. 2 is a left side elevational view thereof;
FIG. 3 is a right side elevational view thereof;
FIG. 4 is a front elevational view thereof;
FIG. 5 is a rear elevational view thereof;
FIG. 6 is a top plan view thereof;
FIG. 7 is a bottom plan view thereof;
FIG. 8 is a perspective view of a third rail support showing a second embodiment of my new design;
FIG. 9 is a left side elevational view thereof;
FIG. 10 is a right side elevational view thereof;
FIG. 11 is a front elevational view thereof;
FIG. 12 is a rear elevational view thereof;
FIG. 13 is a top plan view thereof; and,
FIG. 14 is a bottom plan view thereof.
The parts illustrated in dashed lines in FIGS. 1, 5-8 and 12-14 form no part of the claimed design.

1 Claim, 6 Drawing Sheets

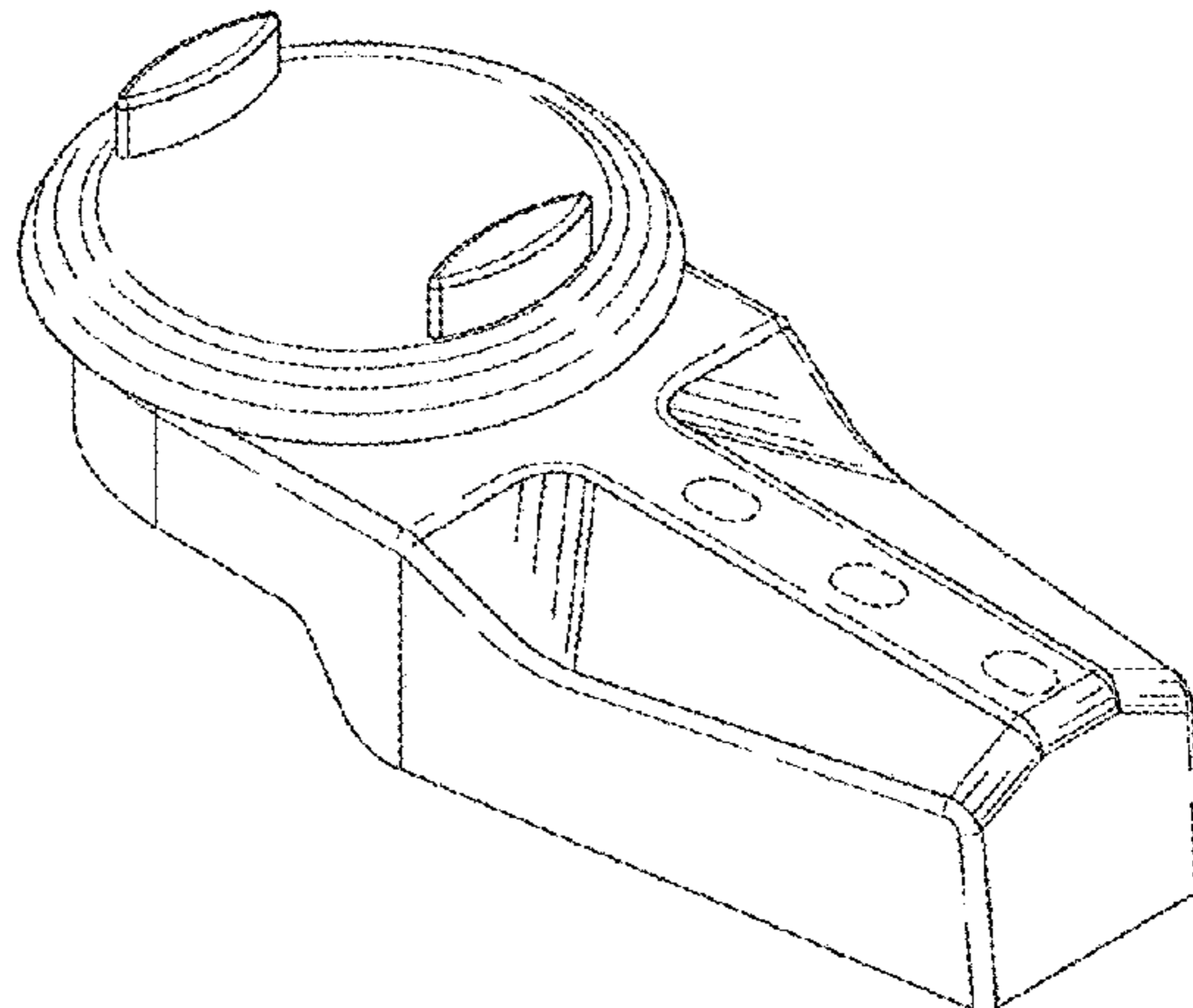
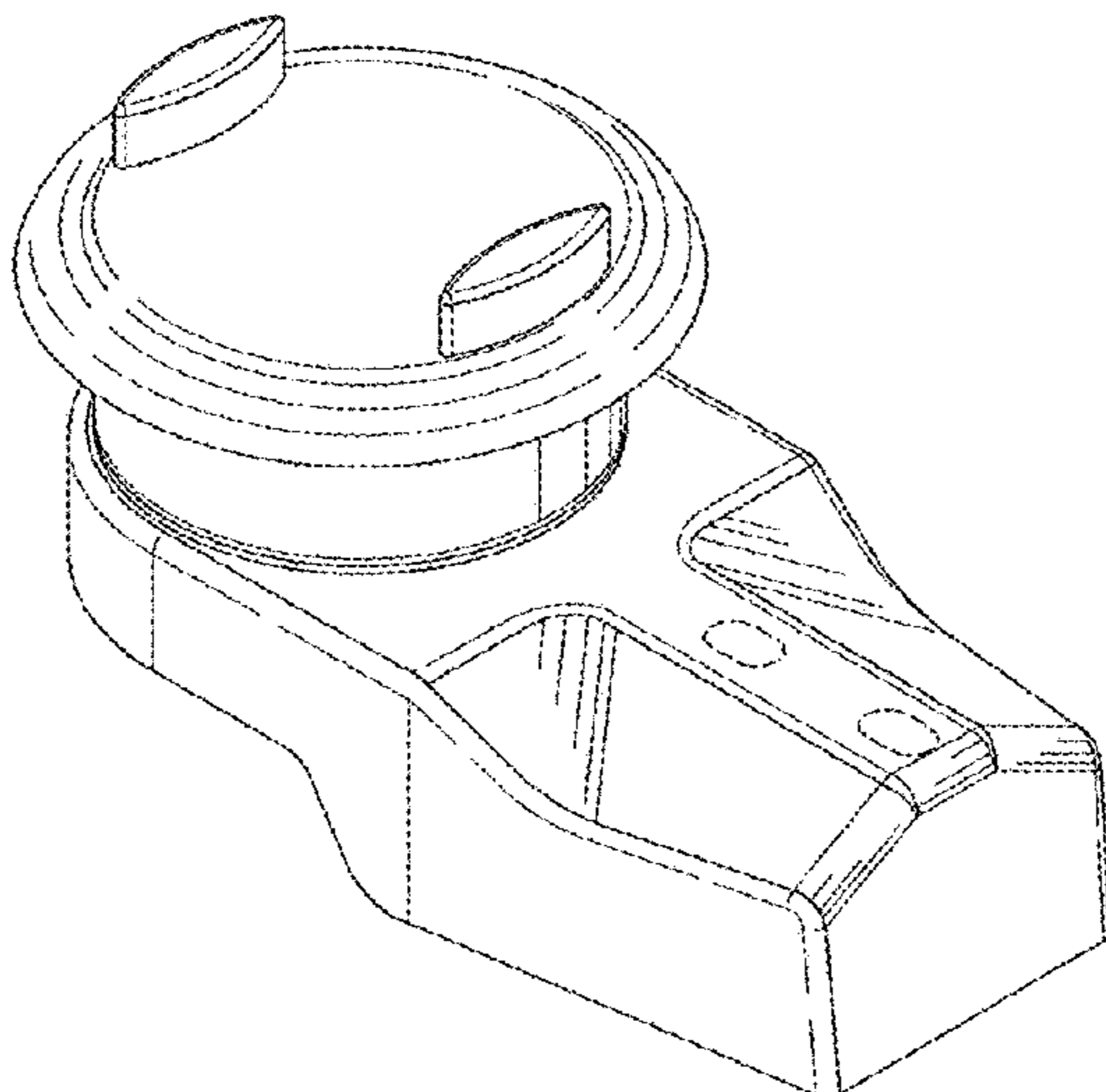

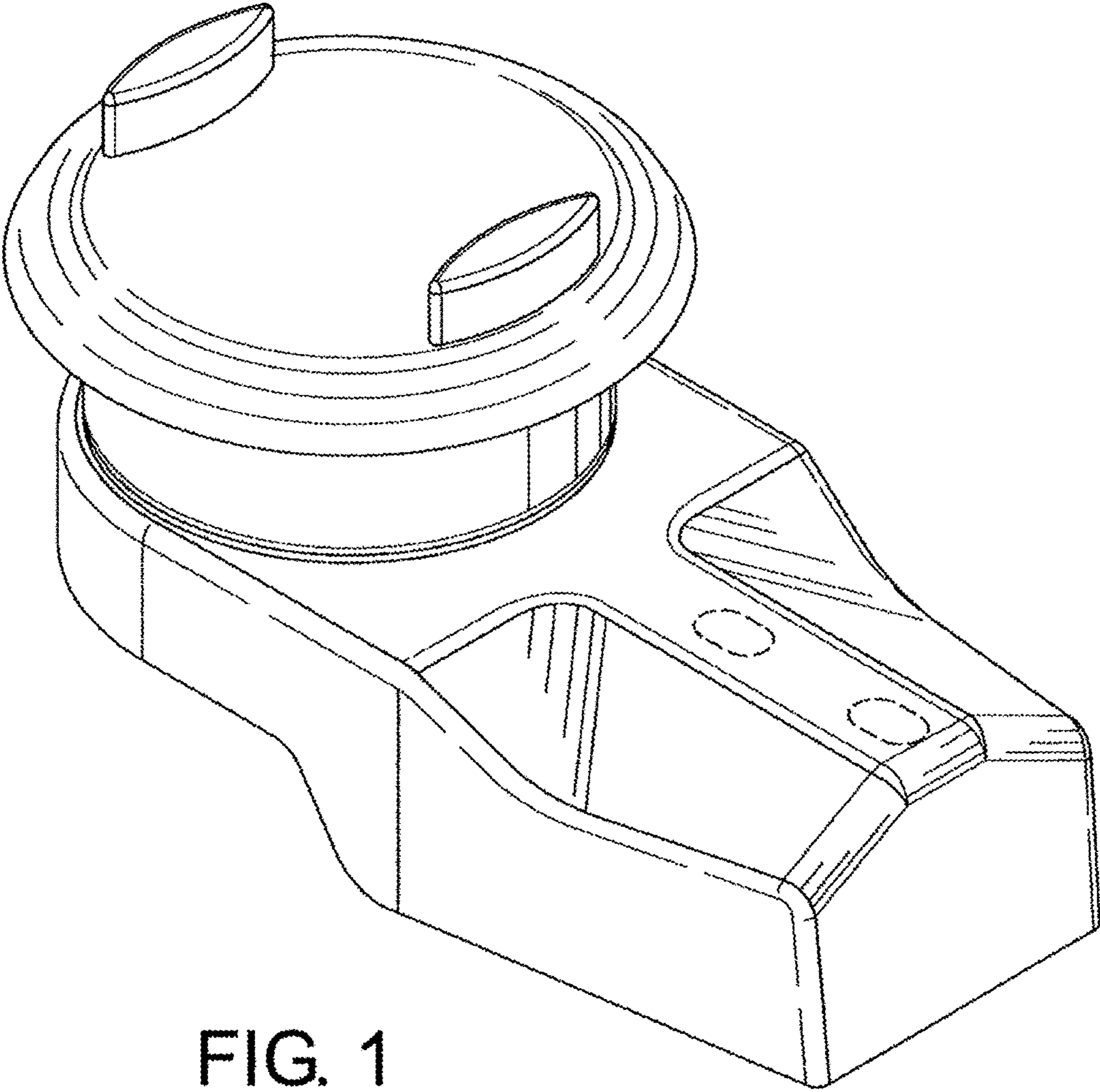

FIG. 1

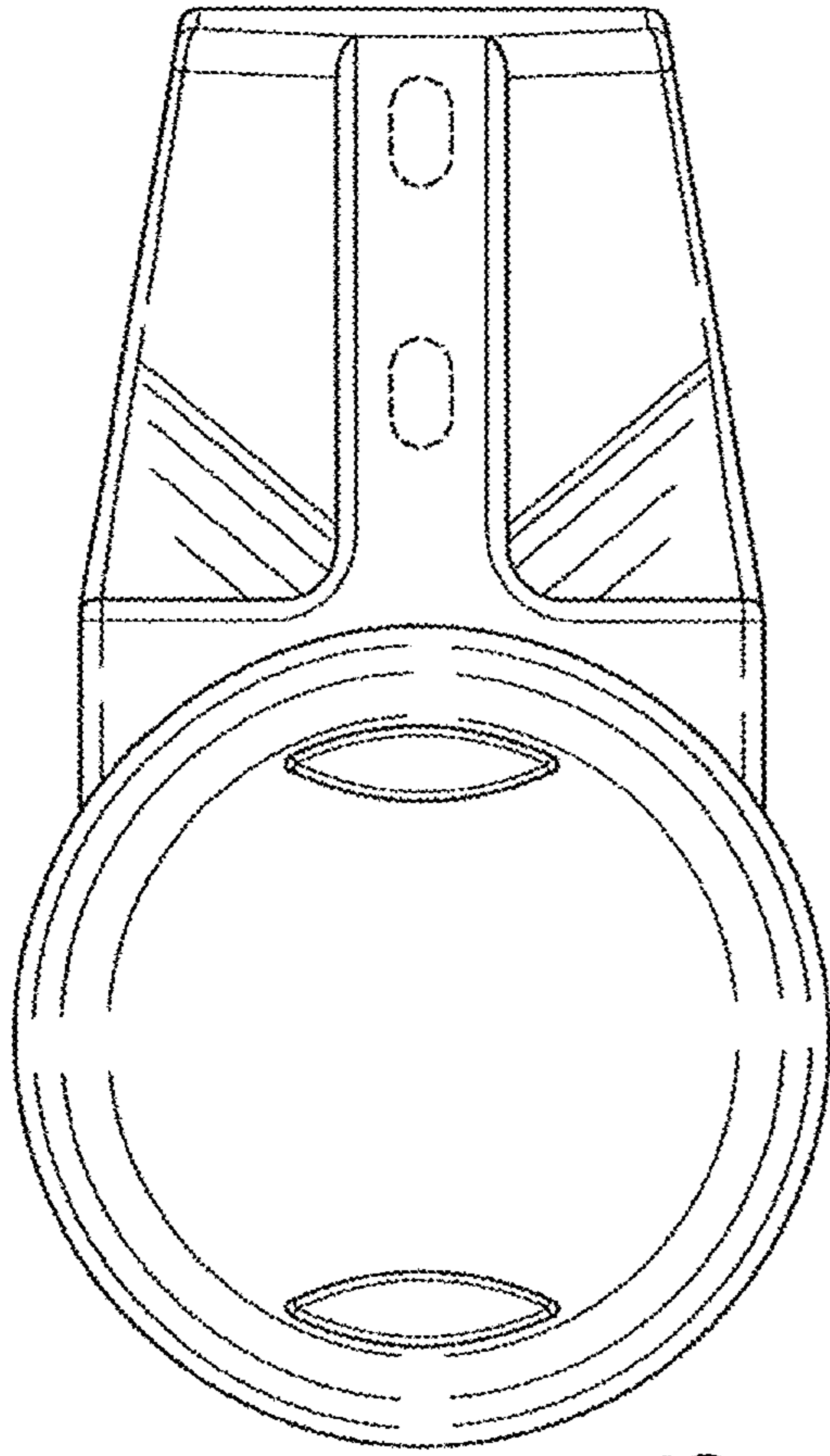

FIG. 6

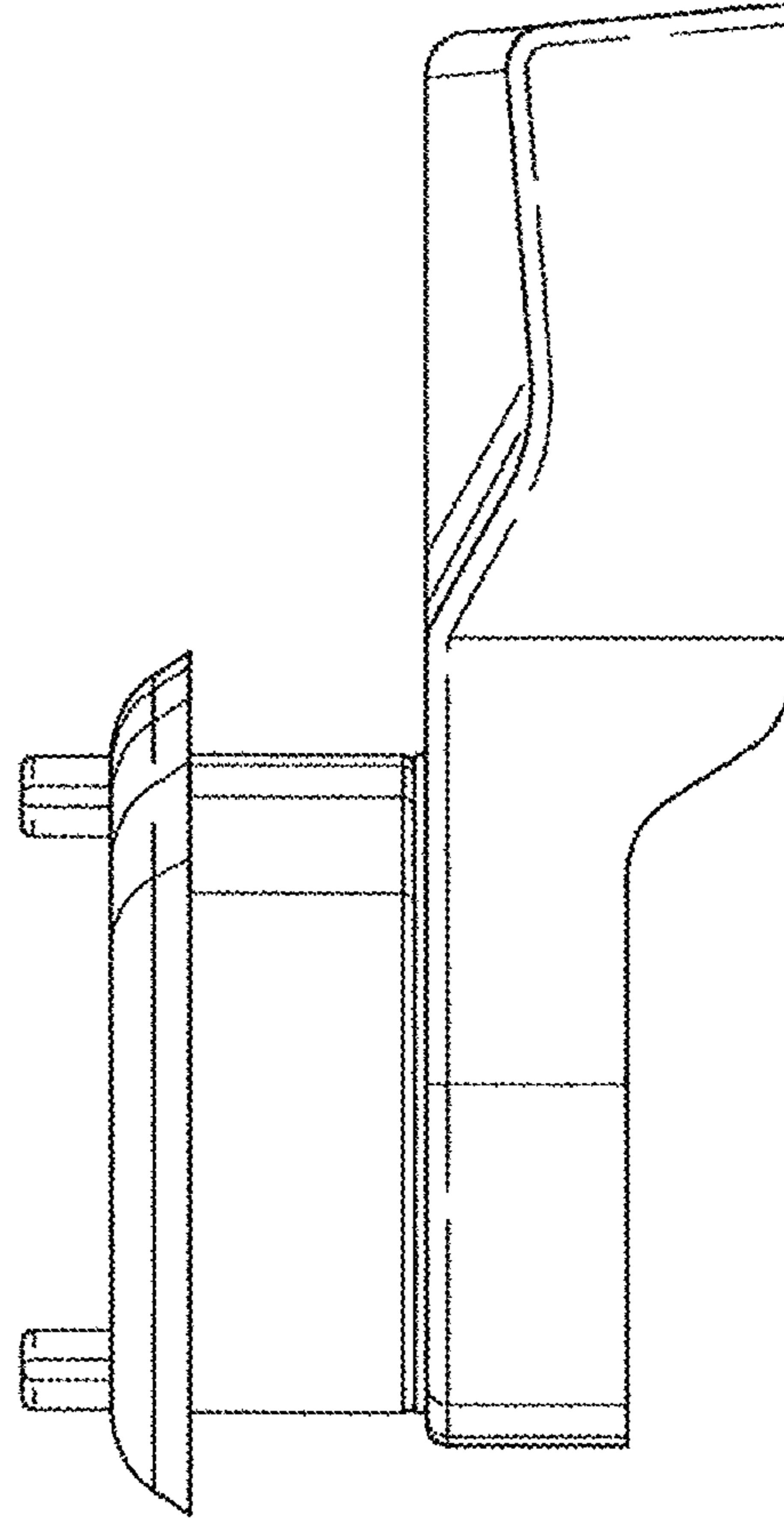

FIG. 2

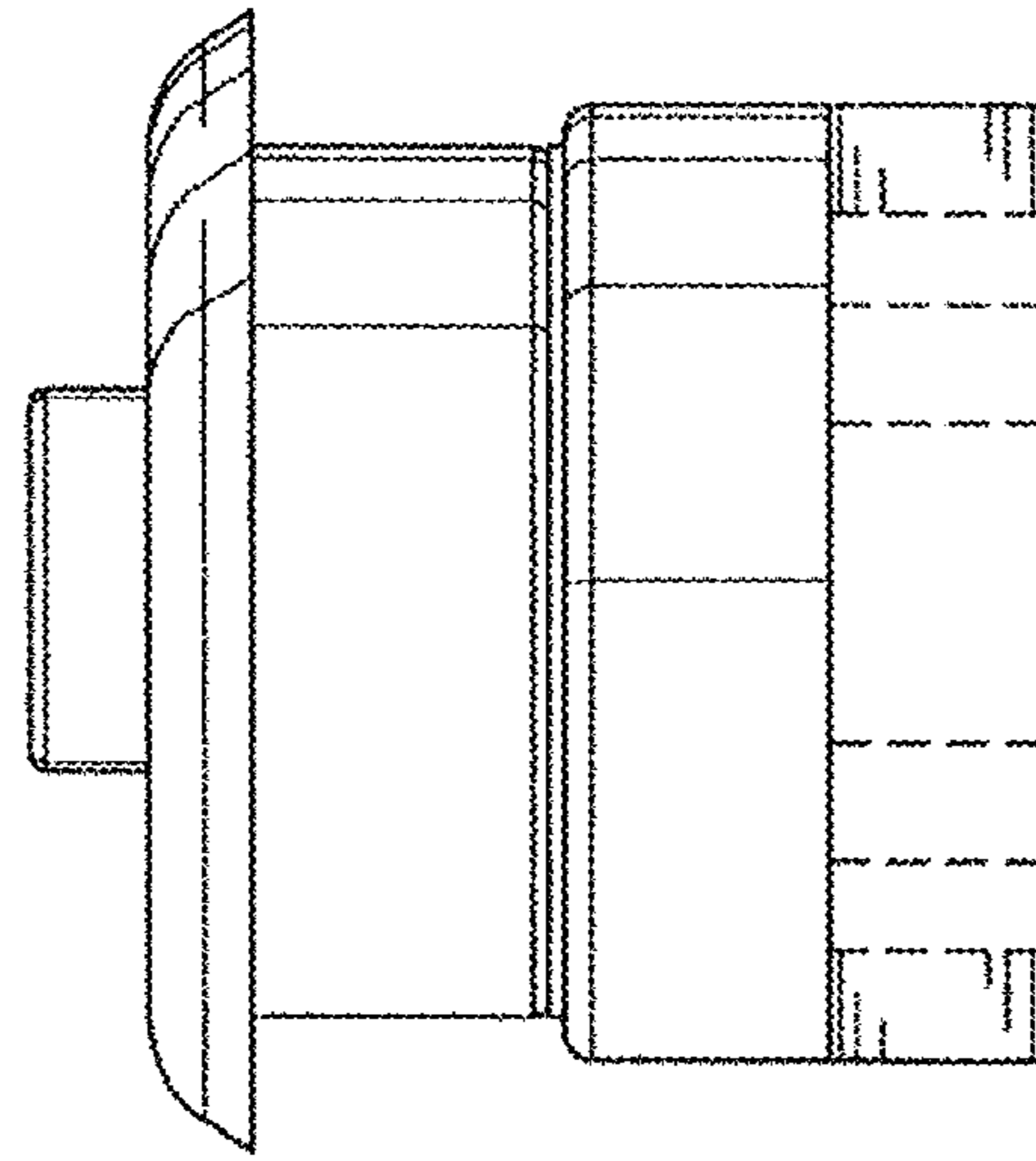

FIG. 5

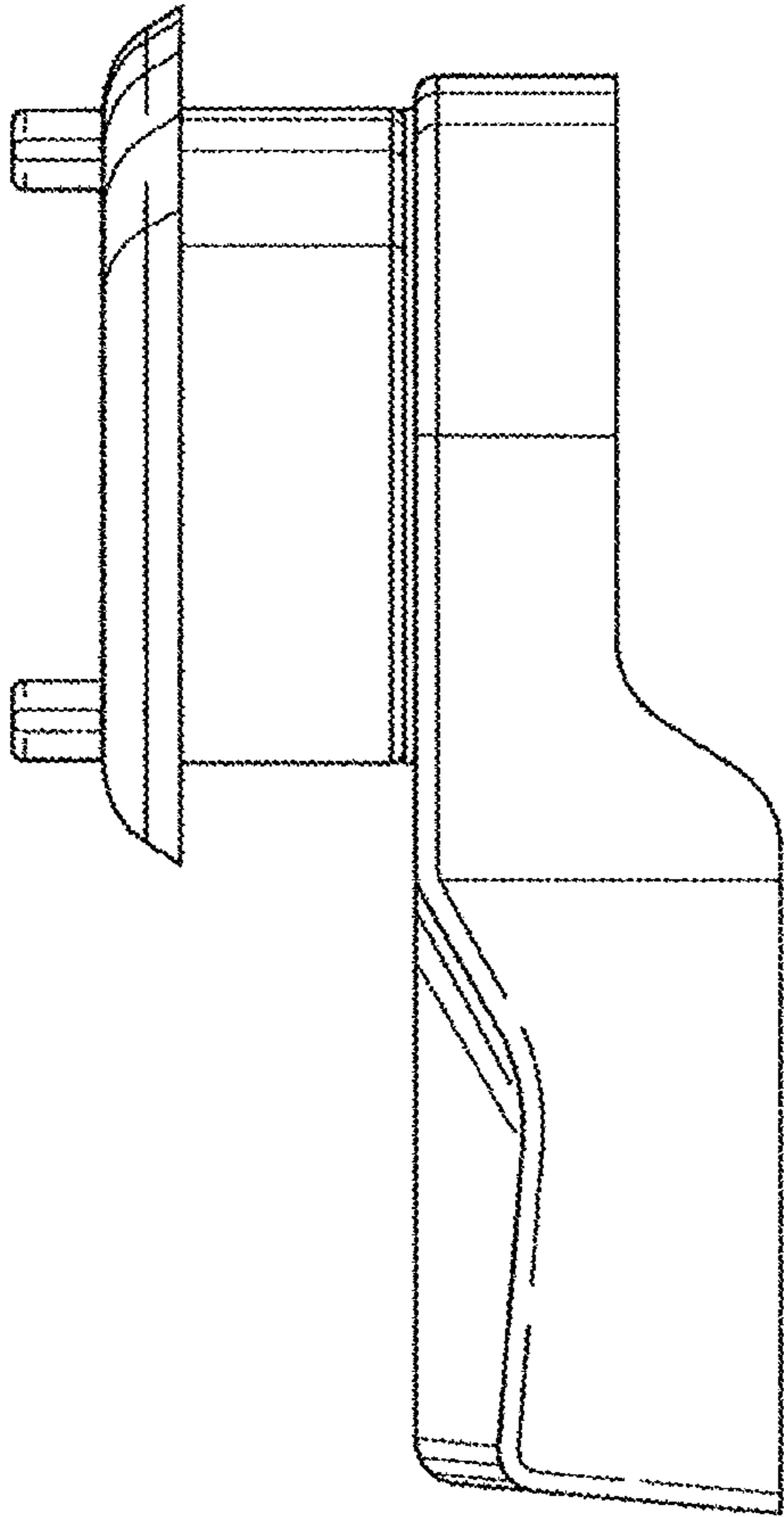

FIG. 3

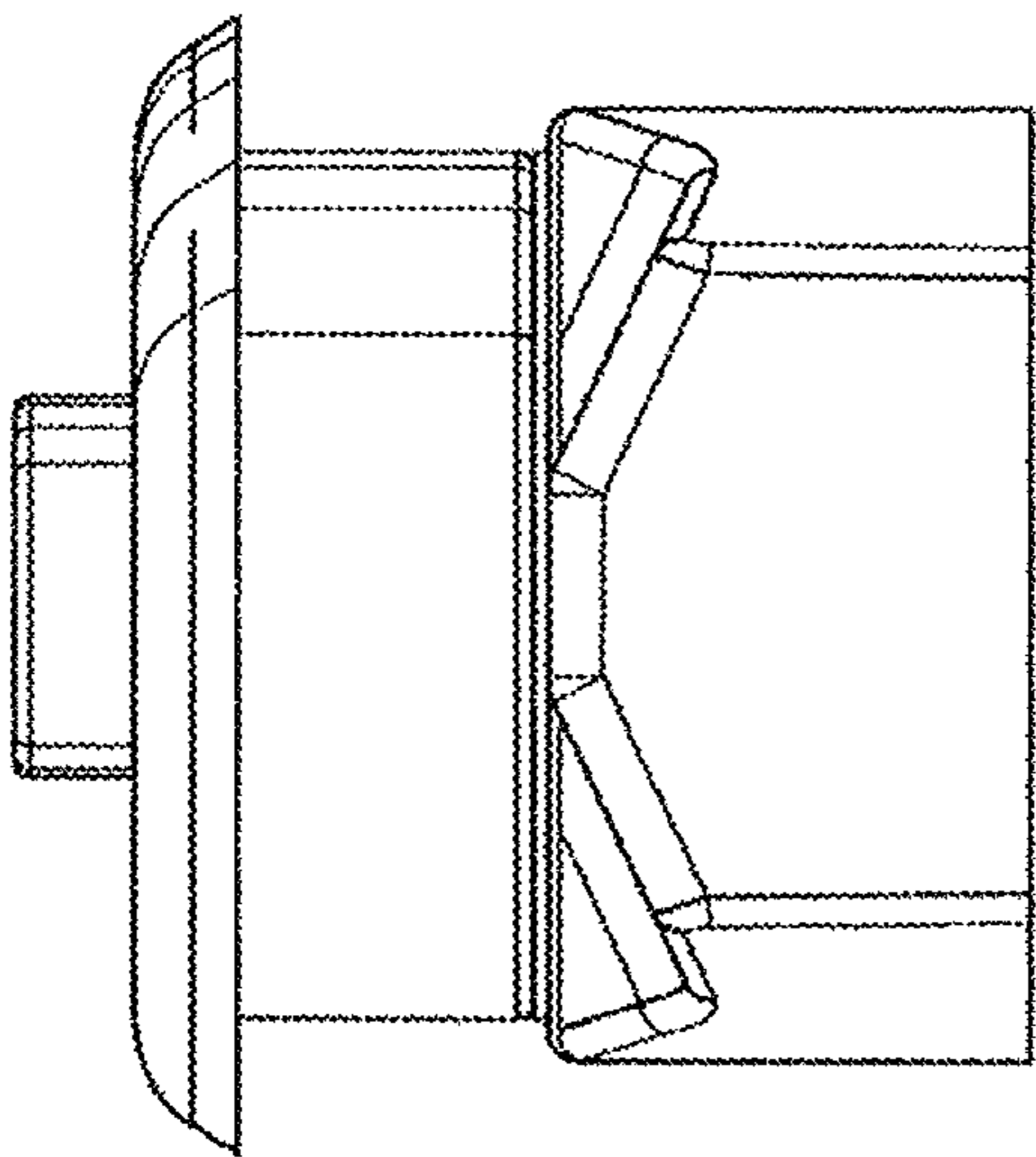

FIG. 4

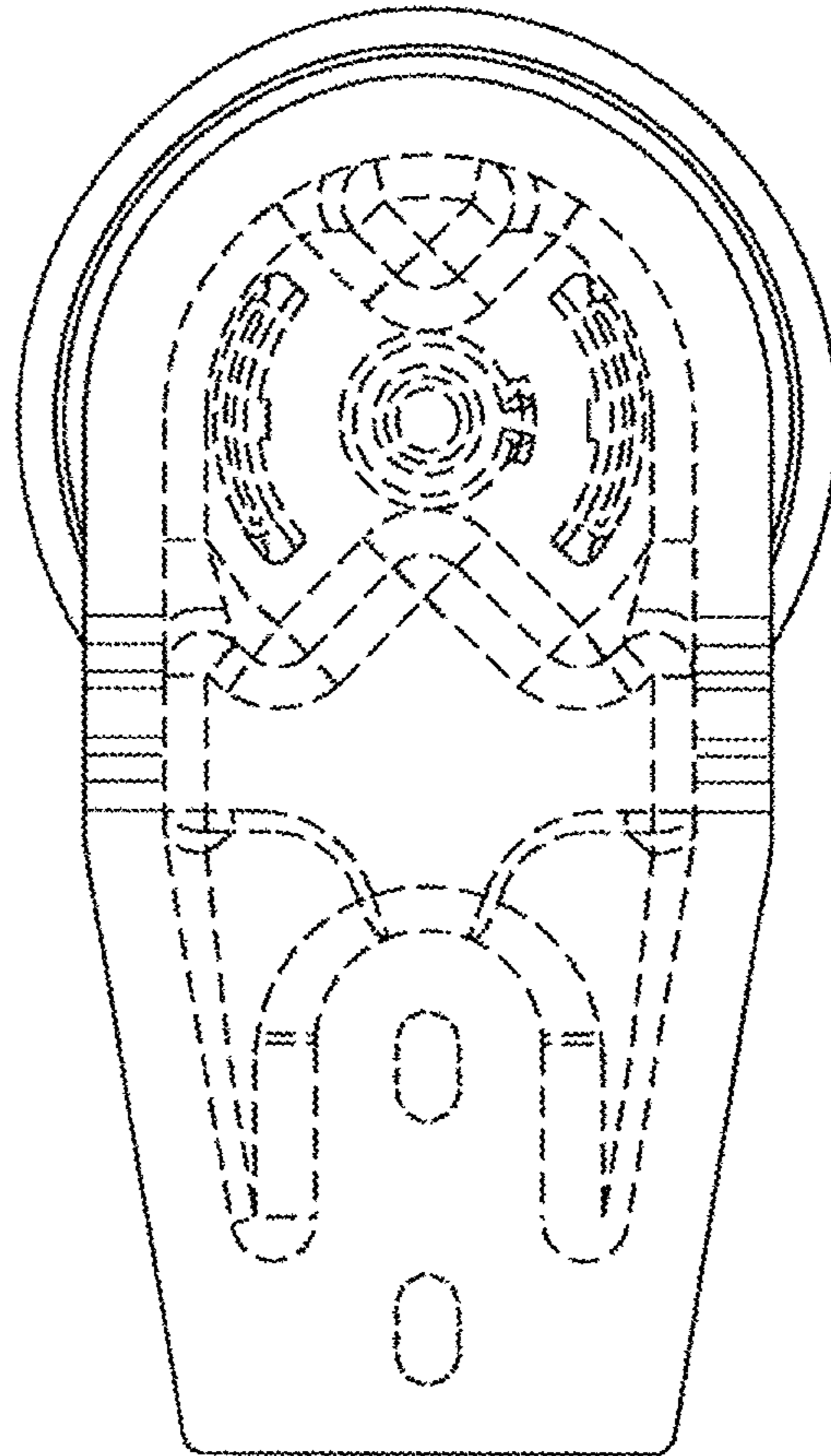

FIG. 7

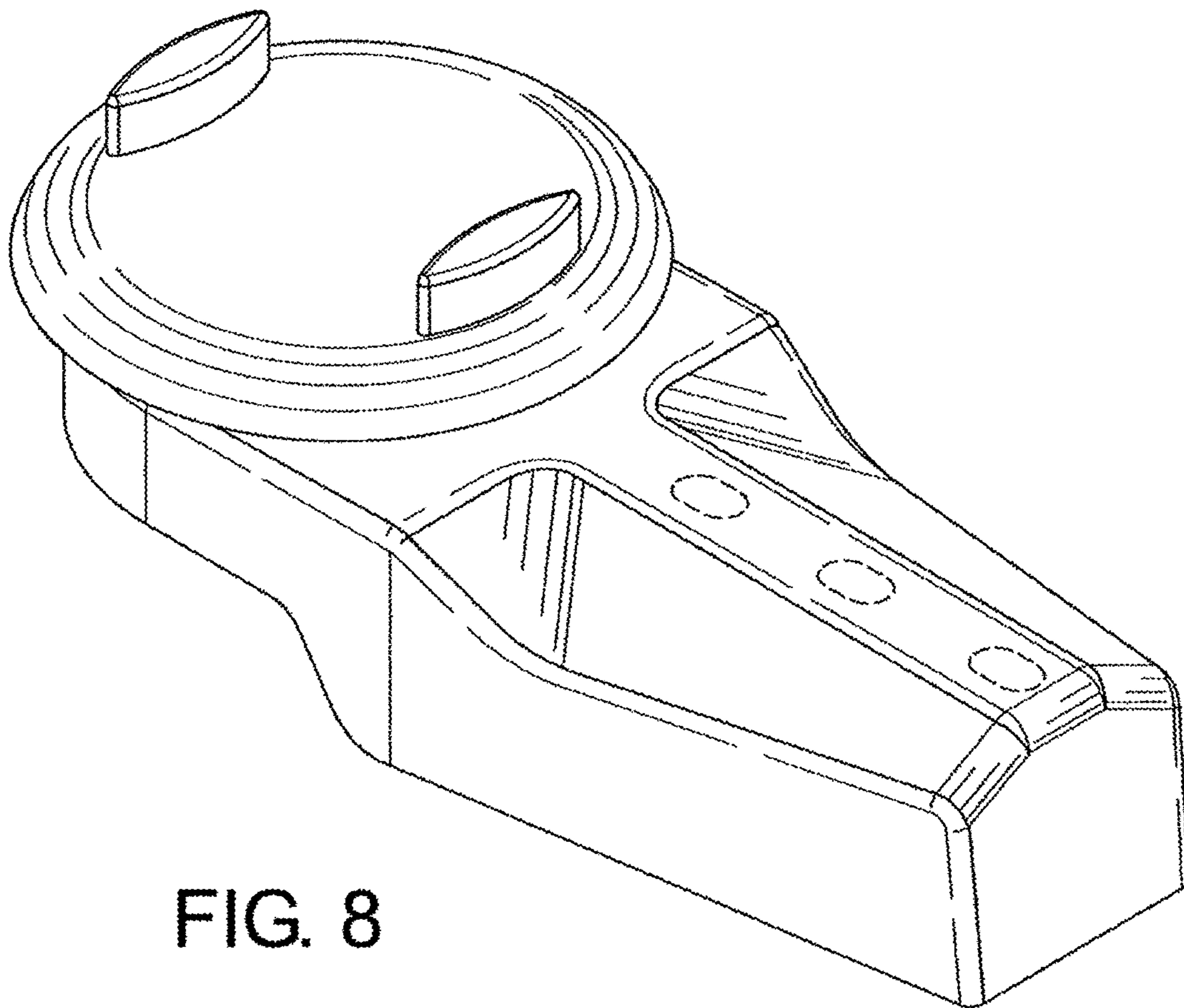

FIG. 8

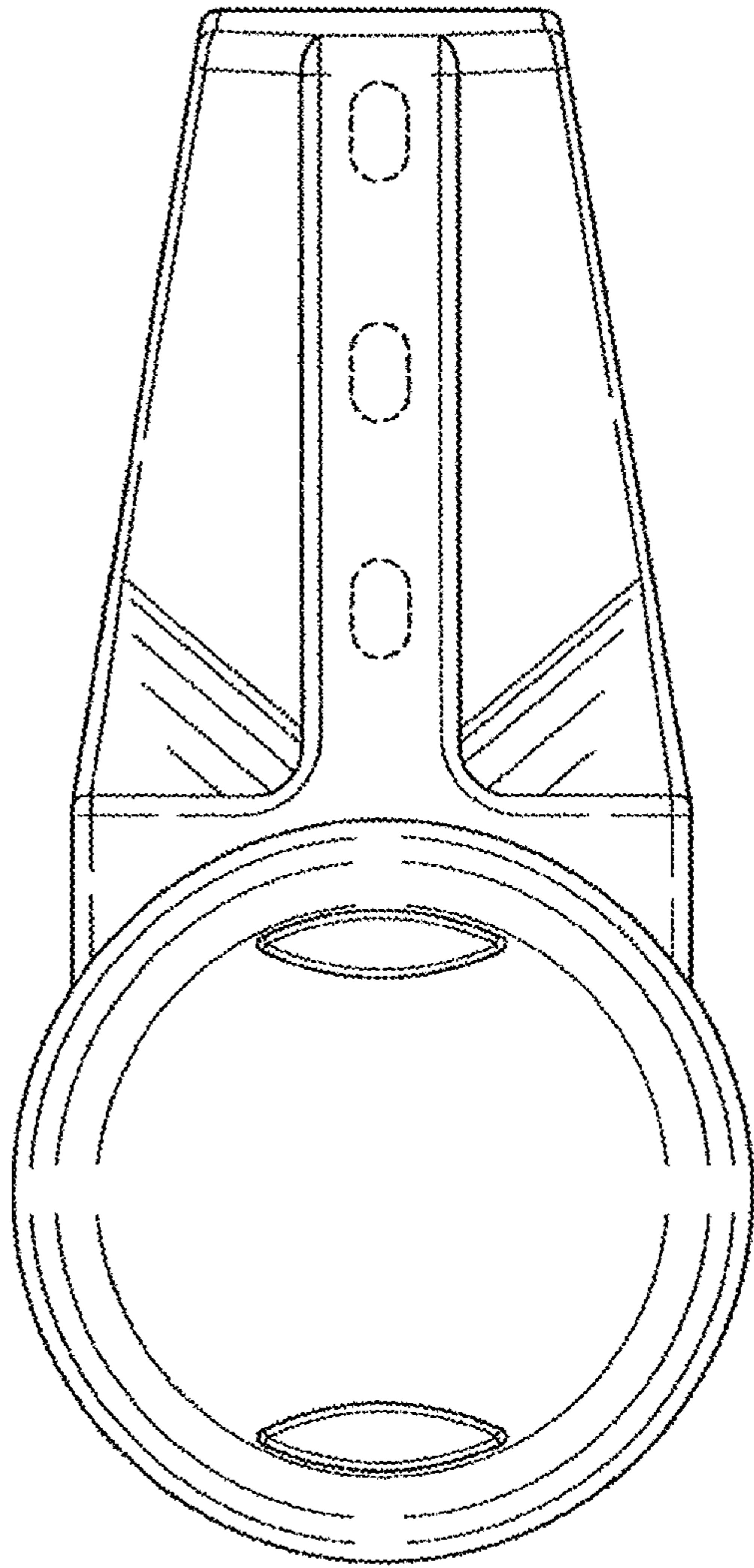

FIG. 13

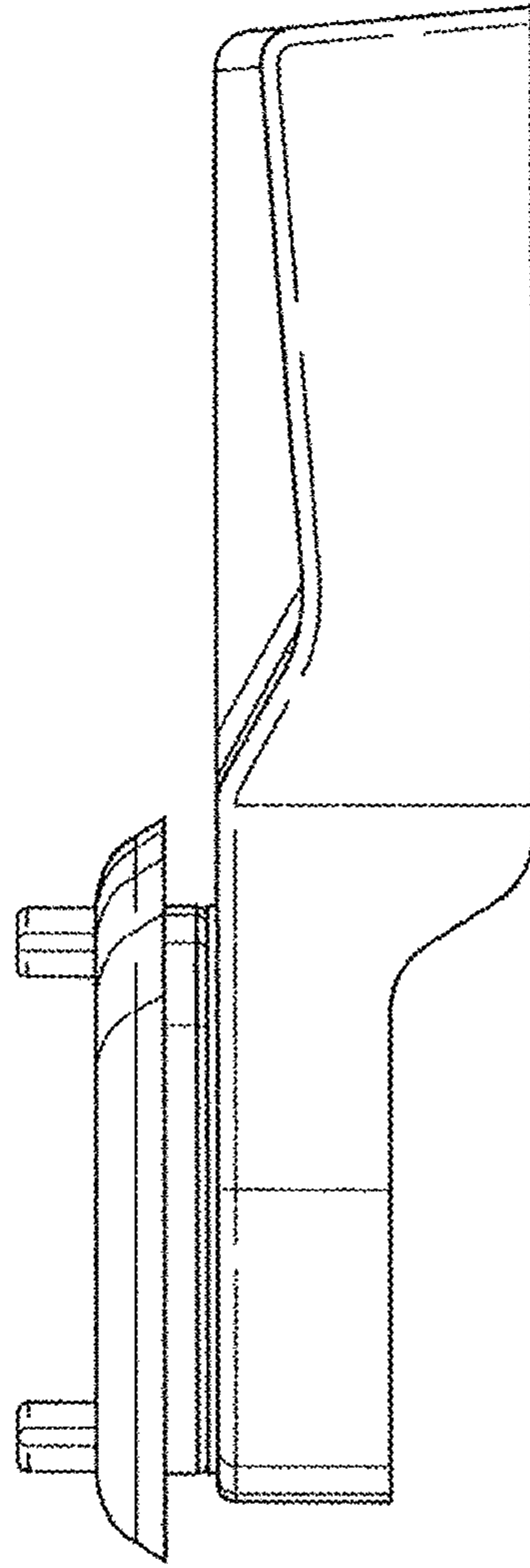

FIG. 9

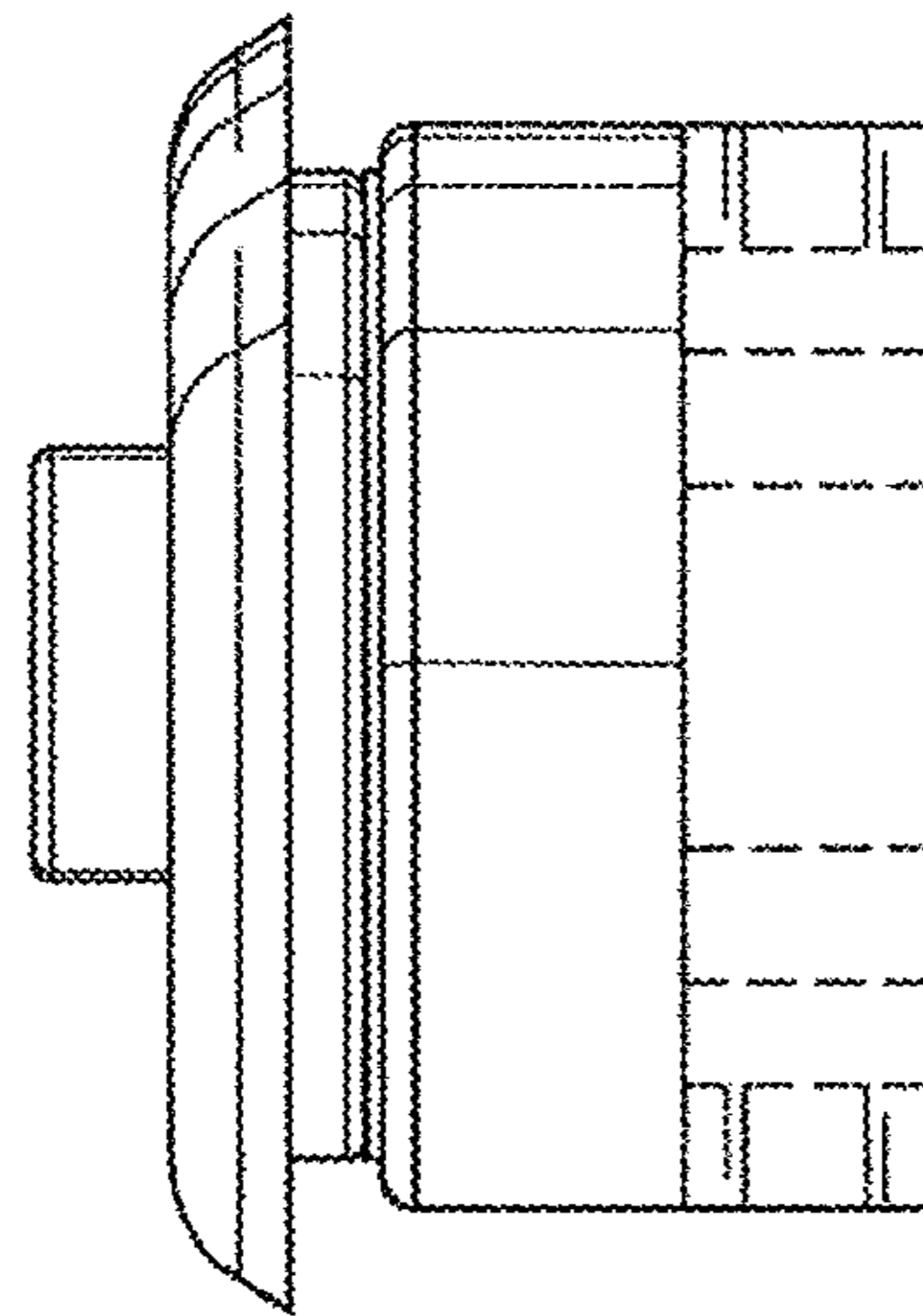

FIG. 12

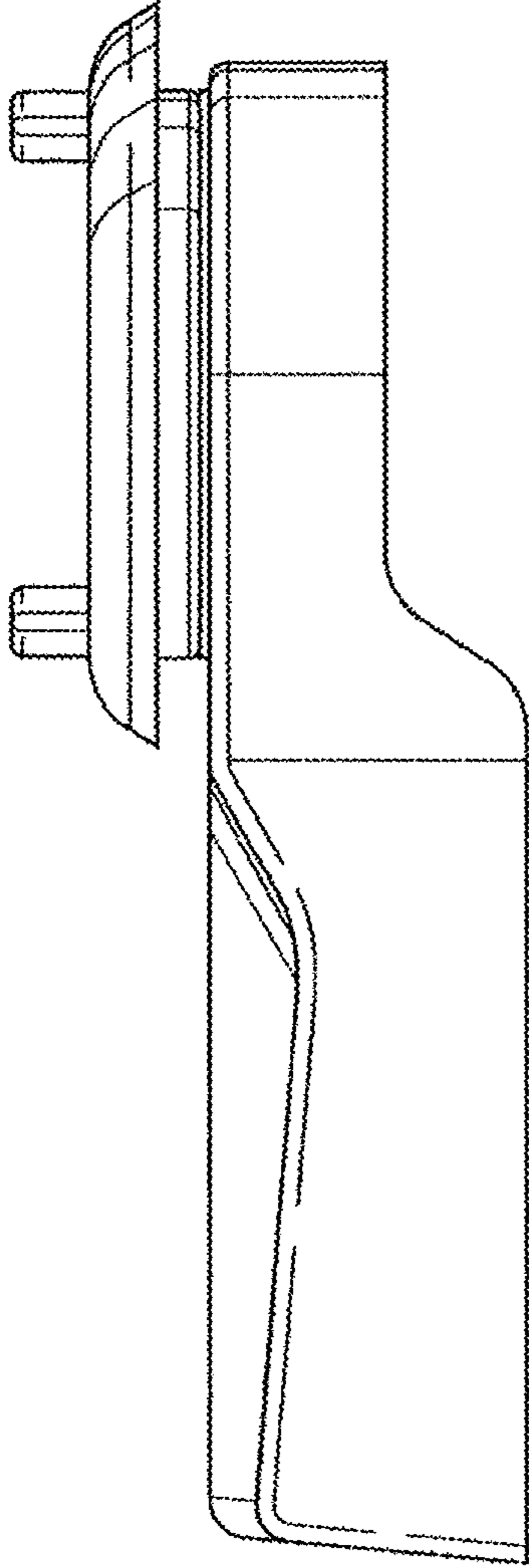

FIG. 10

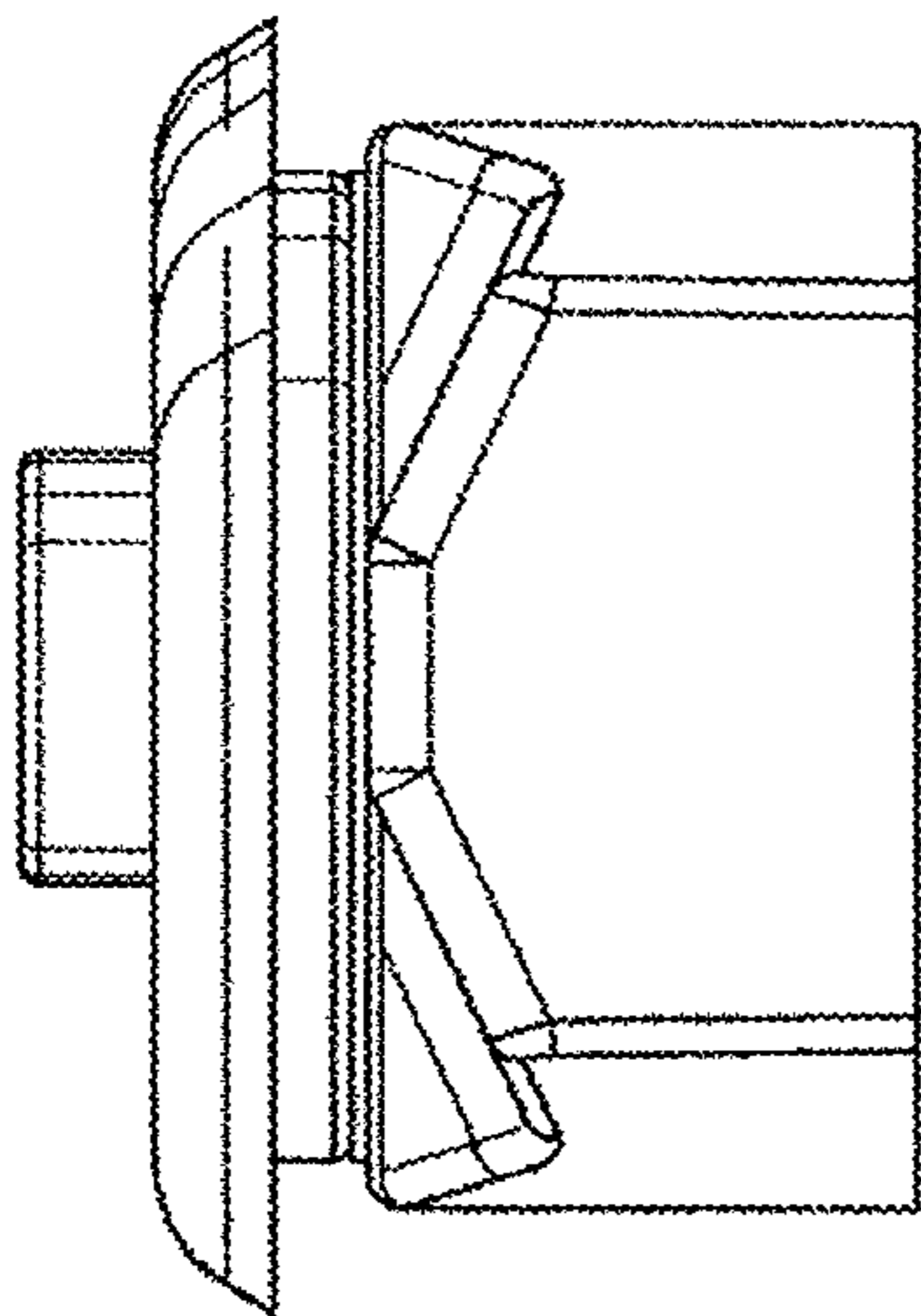

FIG. 11

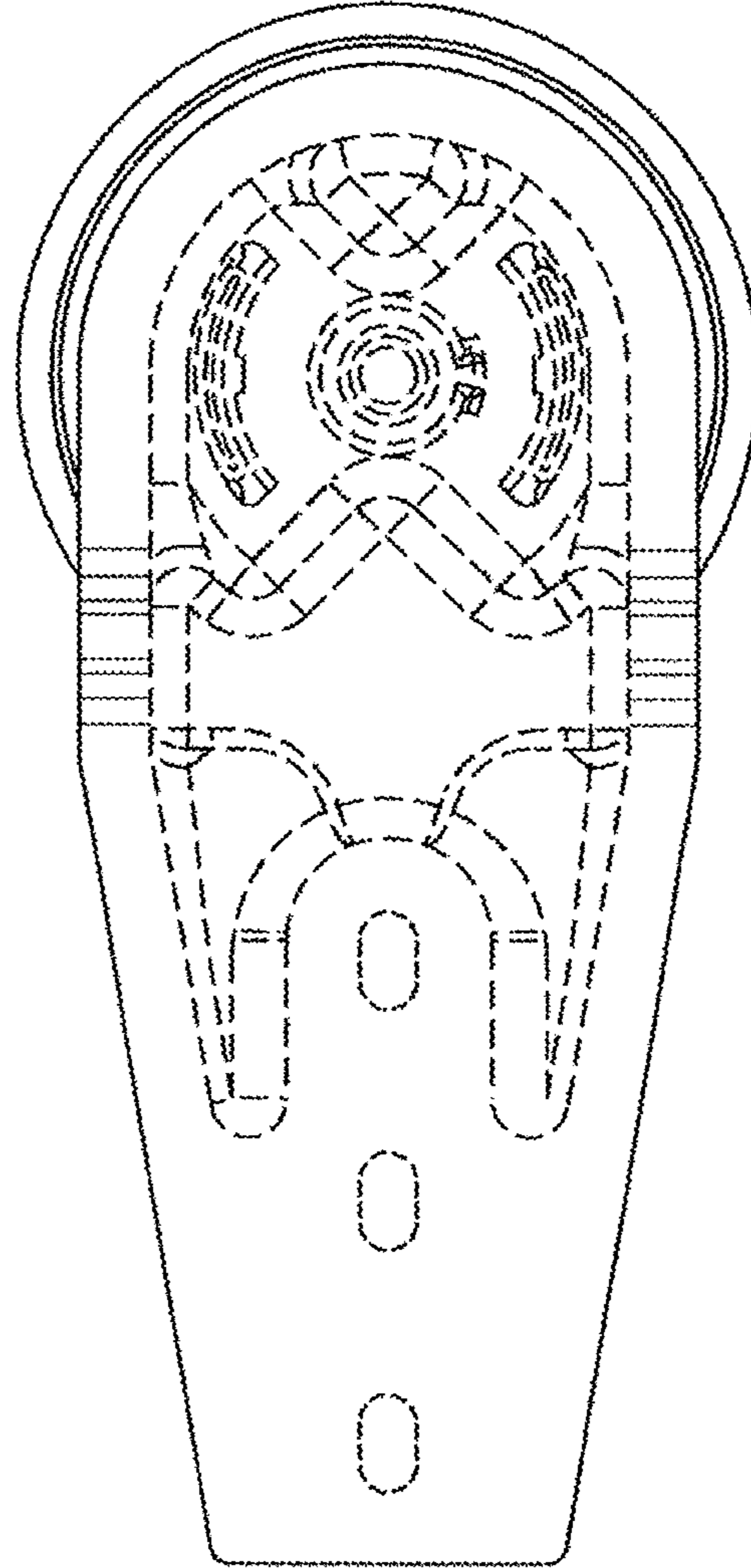

FIG. 14