



US00D885977S

(12) **United States Design Patent**  
**Singleton et al.**

(10) **Patent No.:** **US D885,977 S**  
(45) **Date of Patent:** **\*\* Jun. 2, 2020**

- (54) **ANTI-RAIL ROLLOVER DEVICE**
- (71) Applicant: **Koppers Delaware, Inc.**, Wilmington, DE (US)
- (72) Inventors: **Steven D. Singleton**, Sarver, PA (US);  
**Donald A. Bielski**, Youngstown, OH (US); **Ronald K. Junk**, Cabot, PA (US); **John W. Mospan**, Pittsburgh, PA (US)
- (73) Assignee: **Koppers Delaware, Inc.**, Wilmington, DE (US)
- (\*\*) Term: **15 Years**
- (21) Appl. No.: **29/604,230**
- (22) Filed: **May 16, 2017**
- (51) **LOC (12) Cl.** ..... **12-03**
- (52) **U.S. Cl.**  
USPC ..... **D12/49**
- (58) **Field of Classification Search**  
USPC ..... D12/36-51; D8/382, 383, 384  
CPC ..... E01B 9/00; E01B 9/02; E01B 9/44; E01B 9/46; E01B 9/685; B60M 1/307; B61F 5/38; B61F 5/52; B61G 9/06; B61G 9/10; B61G 9/22; B61G 9/20  
See application file for complete search history.

(56) **References Cited**

**U.S. PATENT DOCUMENTS**

1,783,841	A *	12/1930	Habicht	.....	E01B 9/46 238/304
4,060,197	A	11/1977	Qureshi		
5,096,118	A *	3/1992	Matlock	.....	E01B 9/16 238/298
6,269,752	B1 *	8/2001	Taillon	.....	B61F 5/122 105/198.2
D722,531	S *	2/2015	Pier	.....	D12/49
9,103,074	B1 *	8/2015	Urmson, Jr.	.....	E01B 9/42

D756,844	S	5/2016	Almes et al.		
2004/0155117	A1 *	8/2004	Urmson, Jr.	.....	E01B 9/36 238/287
2006/0118649	A1 *	6/2006	Urmson, Jr.	.....	E01B 9/36 238/287

(Continued)

**OTHER PUBLICATIONS**

Author unknown, Portec Safety Products company brochure, exact date unknown, prior to at least May 16, 2016, US.

(Continued)

*Primary Examiner* — Ania Aman

(74) *Attorney, Agent, or Firm* — The Webb Law Firm

(57) **CLAIM**

The ornamental design for an anti-rail rollover device, as shown and described.

**DESCRIPTION**

FIG. 1 is a perspective view of an anti-rail rollover device showing our new design according to a first embodiment; FIG. 2 is a right view thereof; FIG. 3 is a left view thereof; FIG. 4 is a rear view thereof; FIG. 5 is a front view thereof; FIG. 6 is a top view thereof; FIG. 7 is a bottom view thereof; FIG. 8 is a perspective view of an anti-rail rollover device showing our new design according to a second embodiment; FIG. 9 is a right view thereof; FIG. 10 is a left view thereof; FIG. 11 is a rear view thereof; FIG. 12 is a front view thereof; FIG. 13 is a top view thereof; and, FIG. 14 is a bottom view thereof. The broken line showings of FIGS. 1, 5, 6, and 7 are environmental only and not part of the claimed design.

**1 Claim, 14 Drawing Sheets**

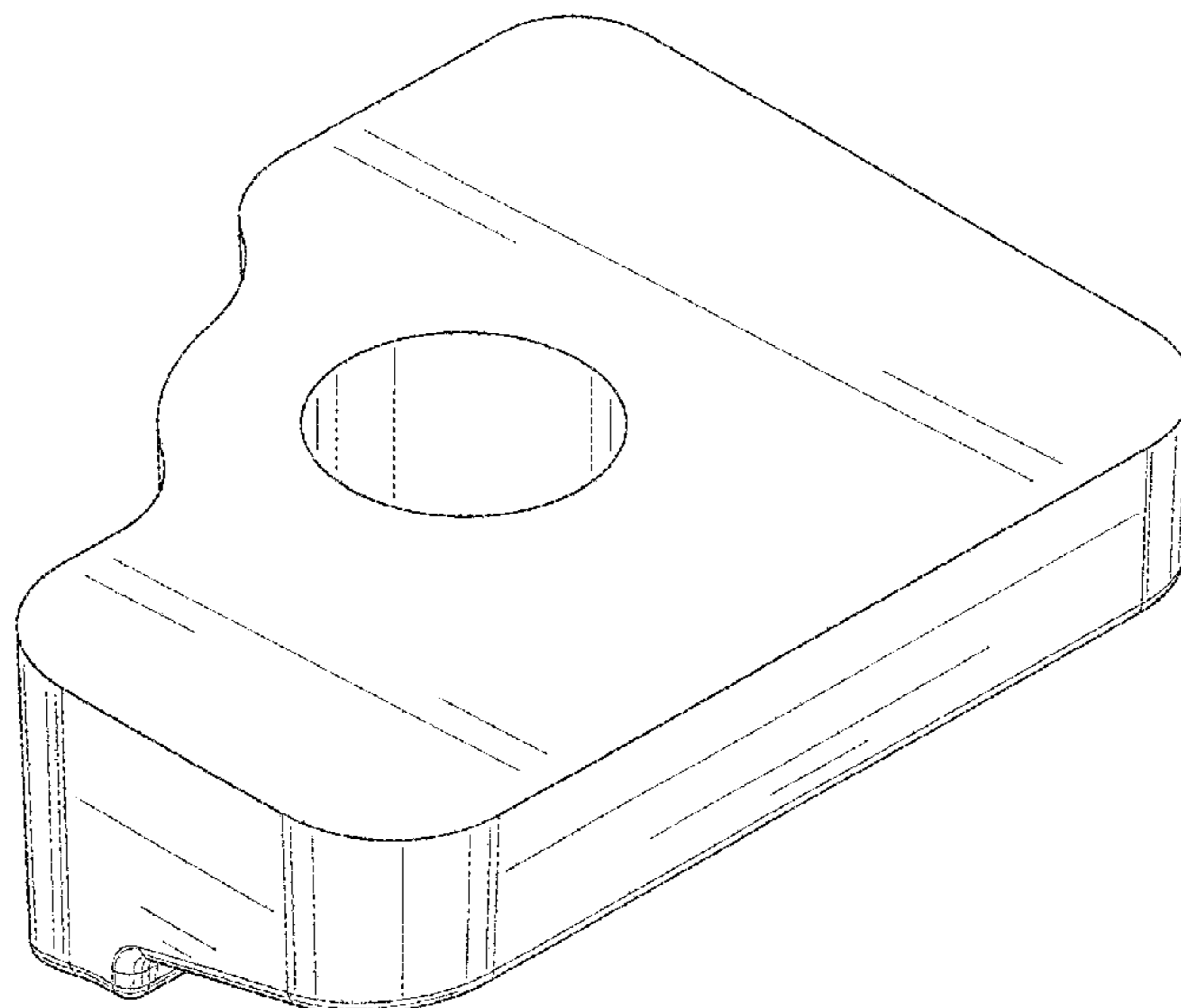

(56)

**References Cited**

U.S. PATENT DOCUMENTS

2017/0320404 A1\* 11/2017 Steininger ..... B60M 1/307  
2018/0257677 A1\* 9/2018 Coseglia ..... B61F 5/122

OTHER PUBLICATIONS

Author unknown, Portec Railway Products company brochure, exact date unknown, prior to at least May 16, 2016, Railway Products Division, Oak Brook, IL, US.

Author unknown, "Fasteners help buffer bridge against track loads", Railway Track & Structures, Apr. 1983, CN Bridge.

\* cited by examiner

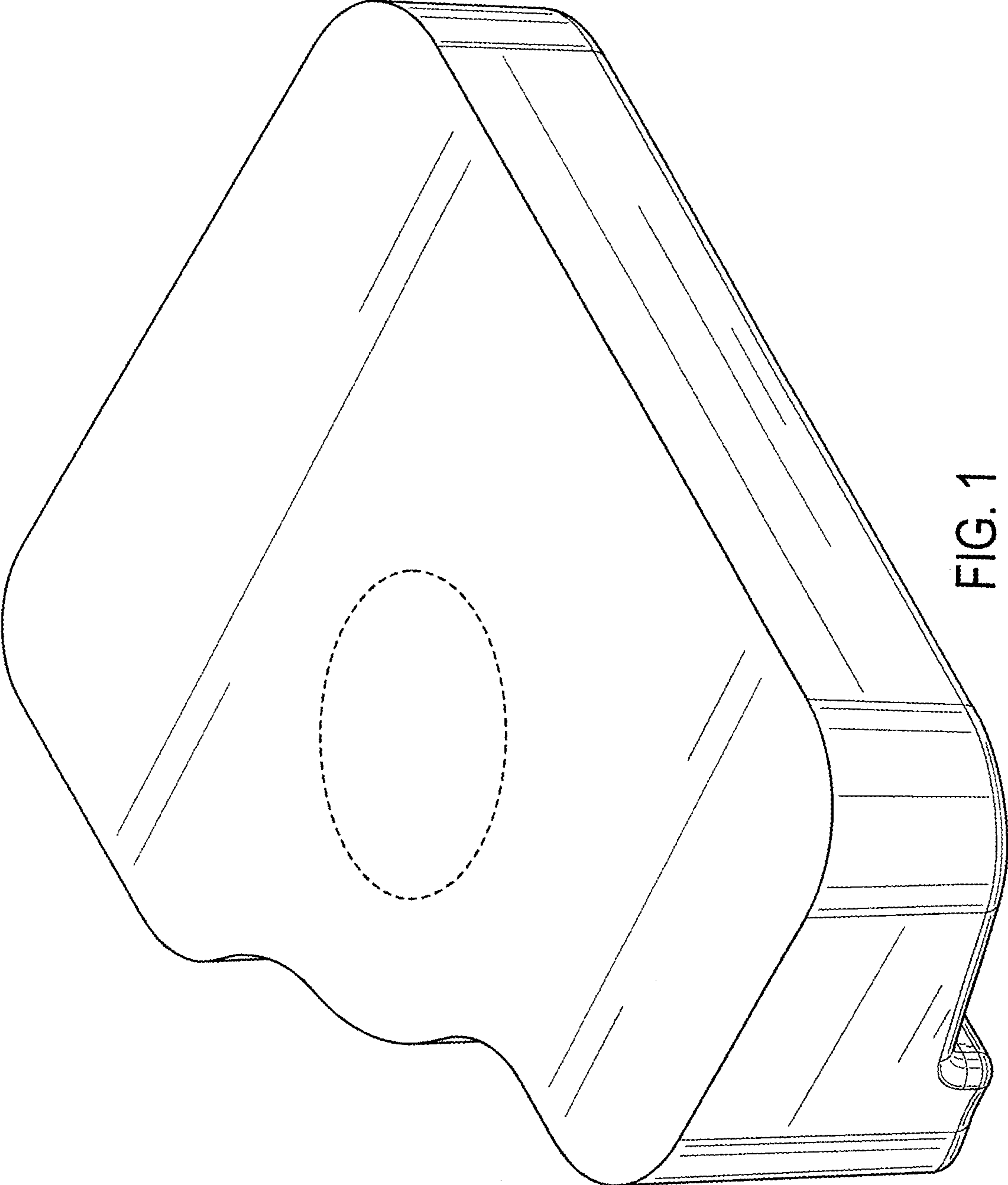

FIG. 1

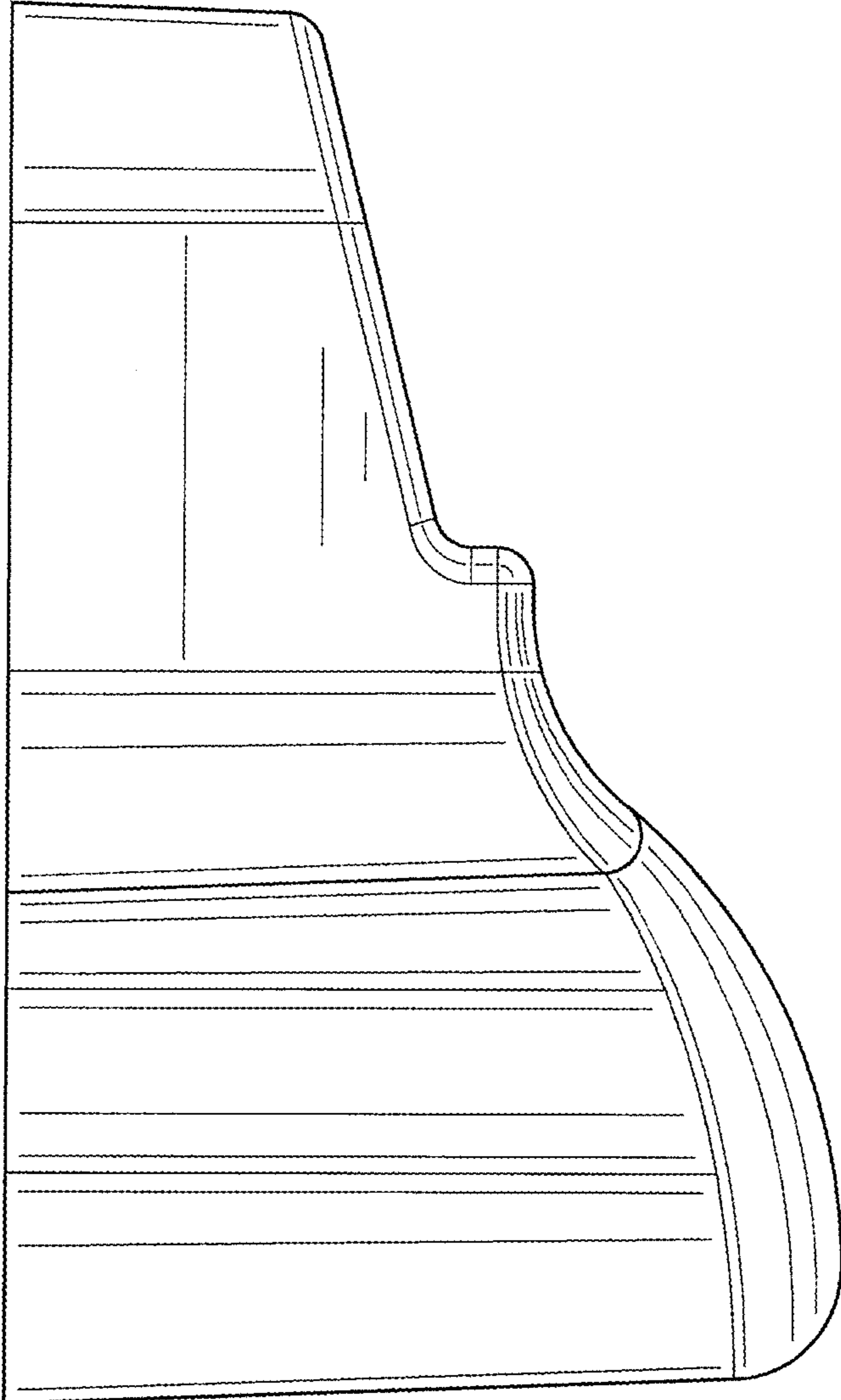

FIG. 2

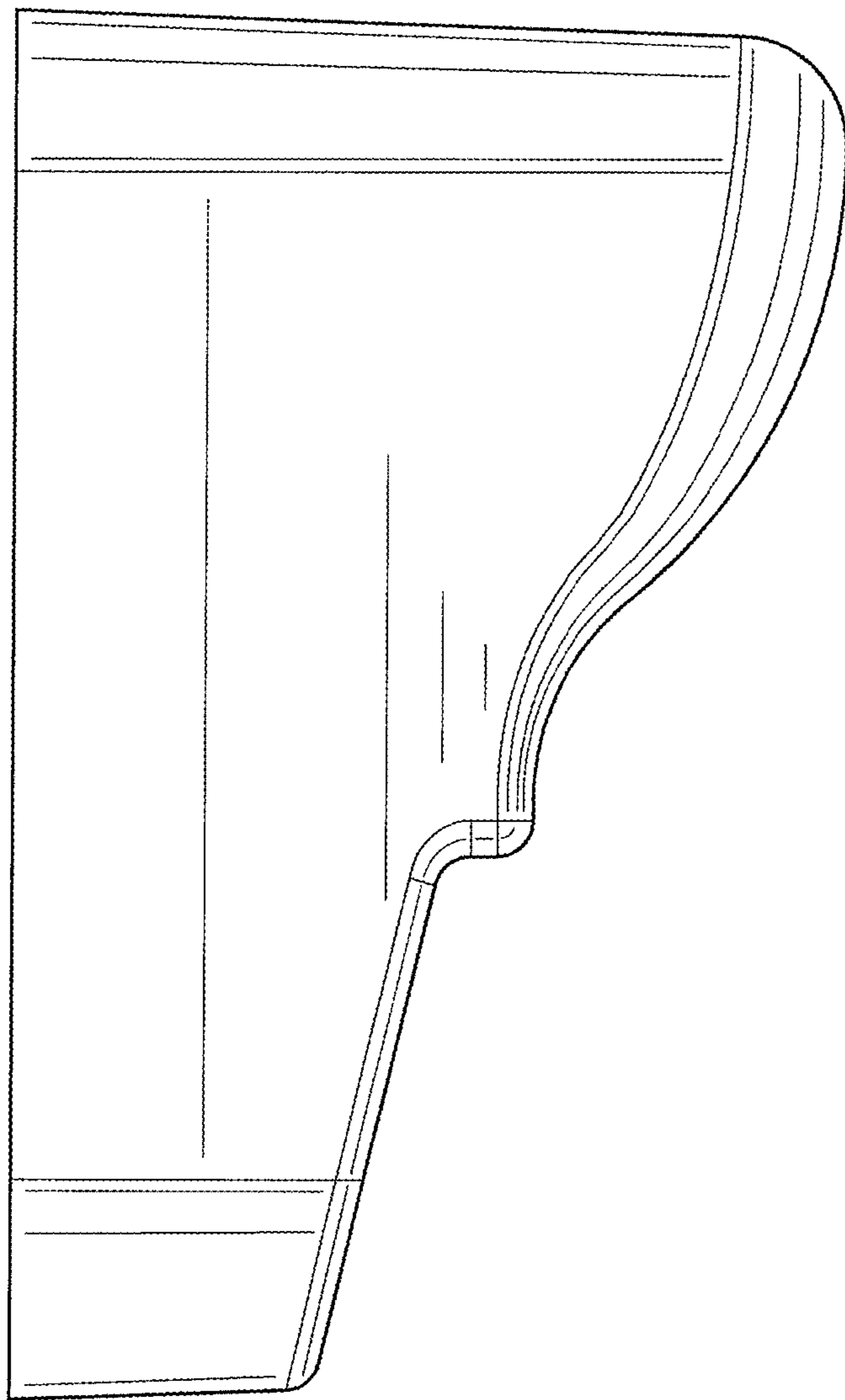

FIG. 3

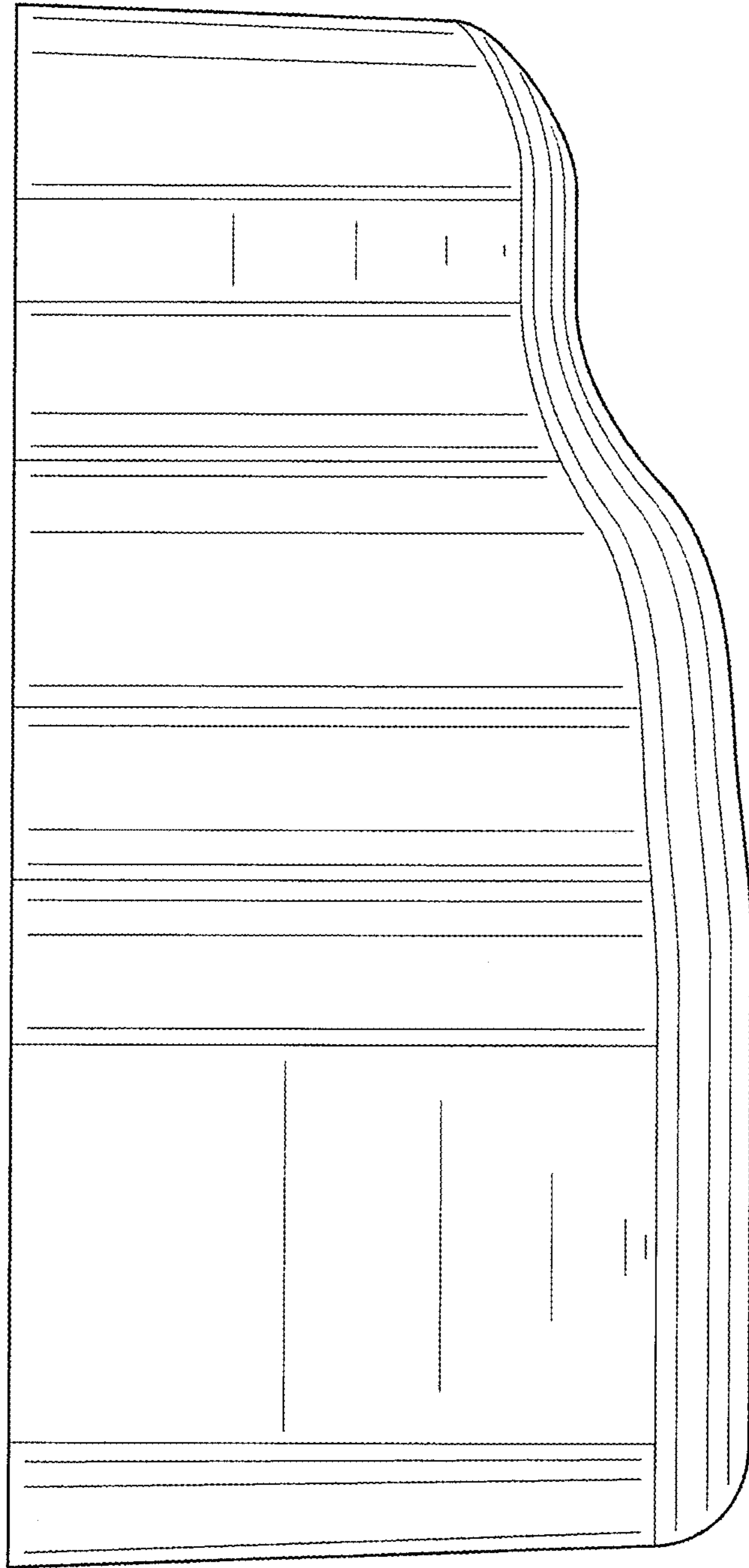

FIG. 4

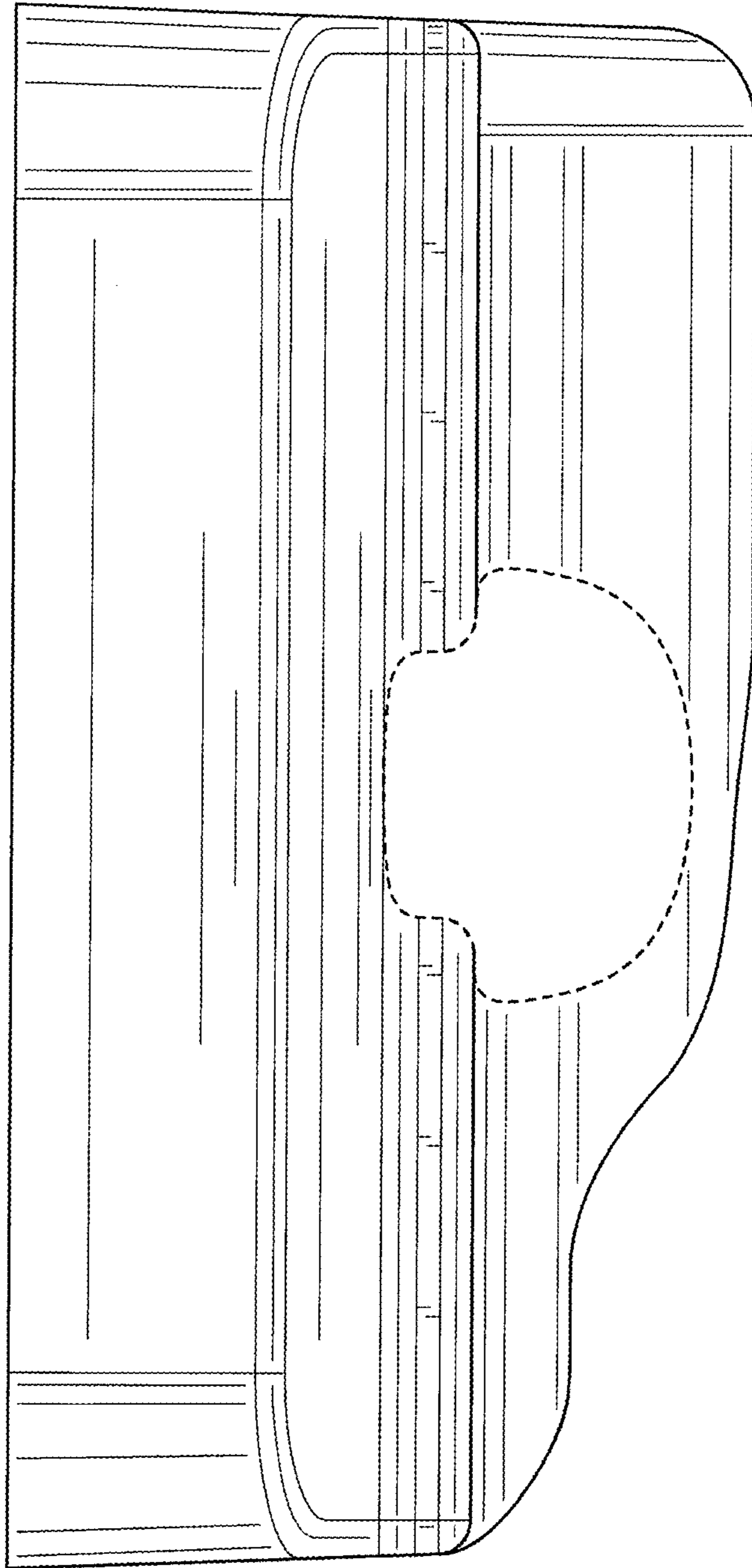

FIG. 5

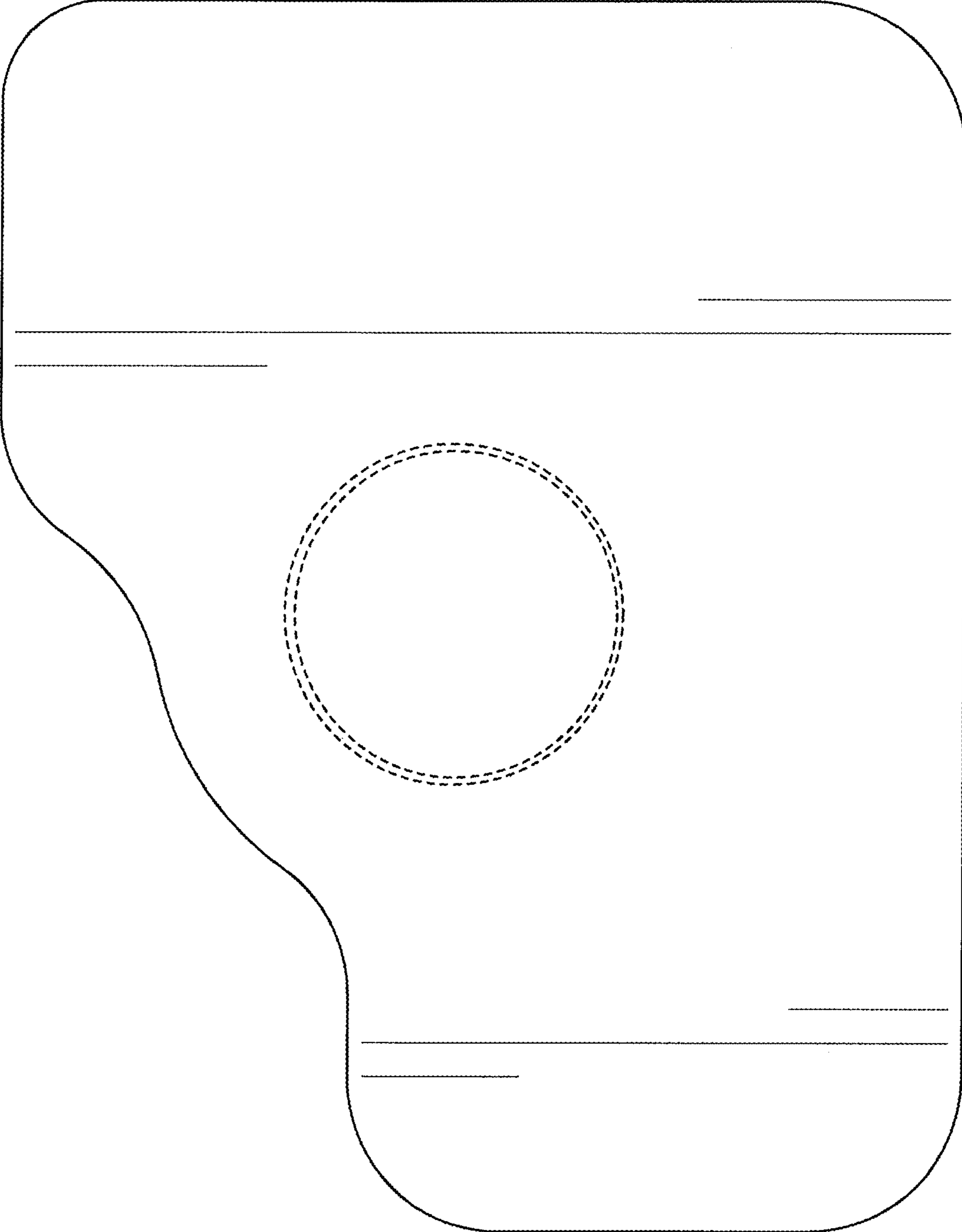

FIG. 6



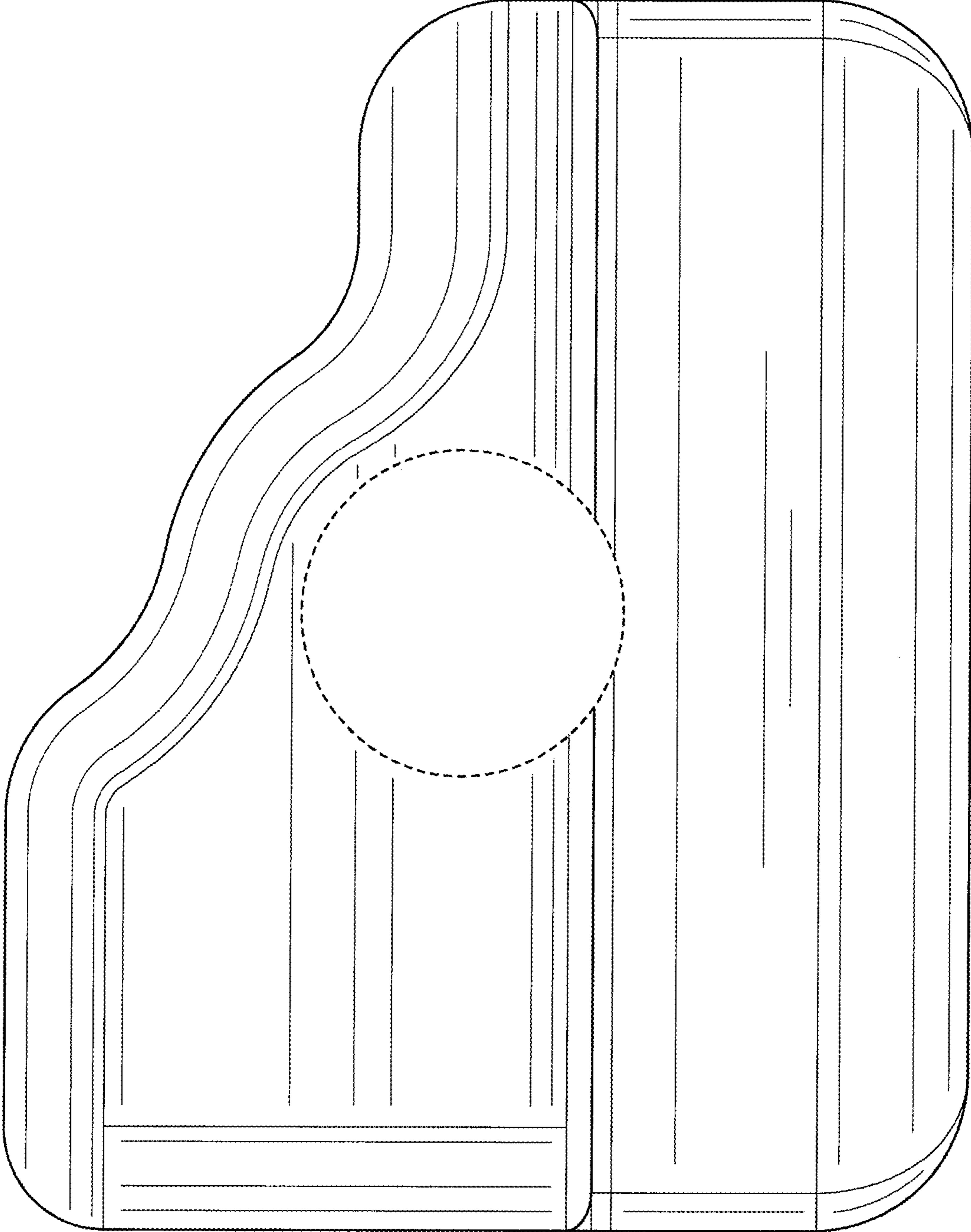

FIG. 7

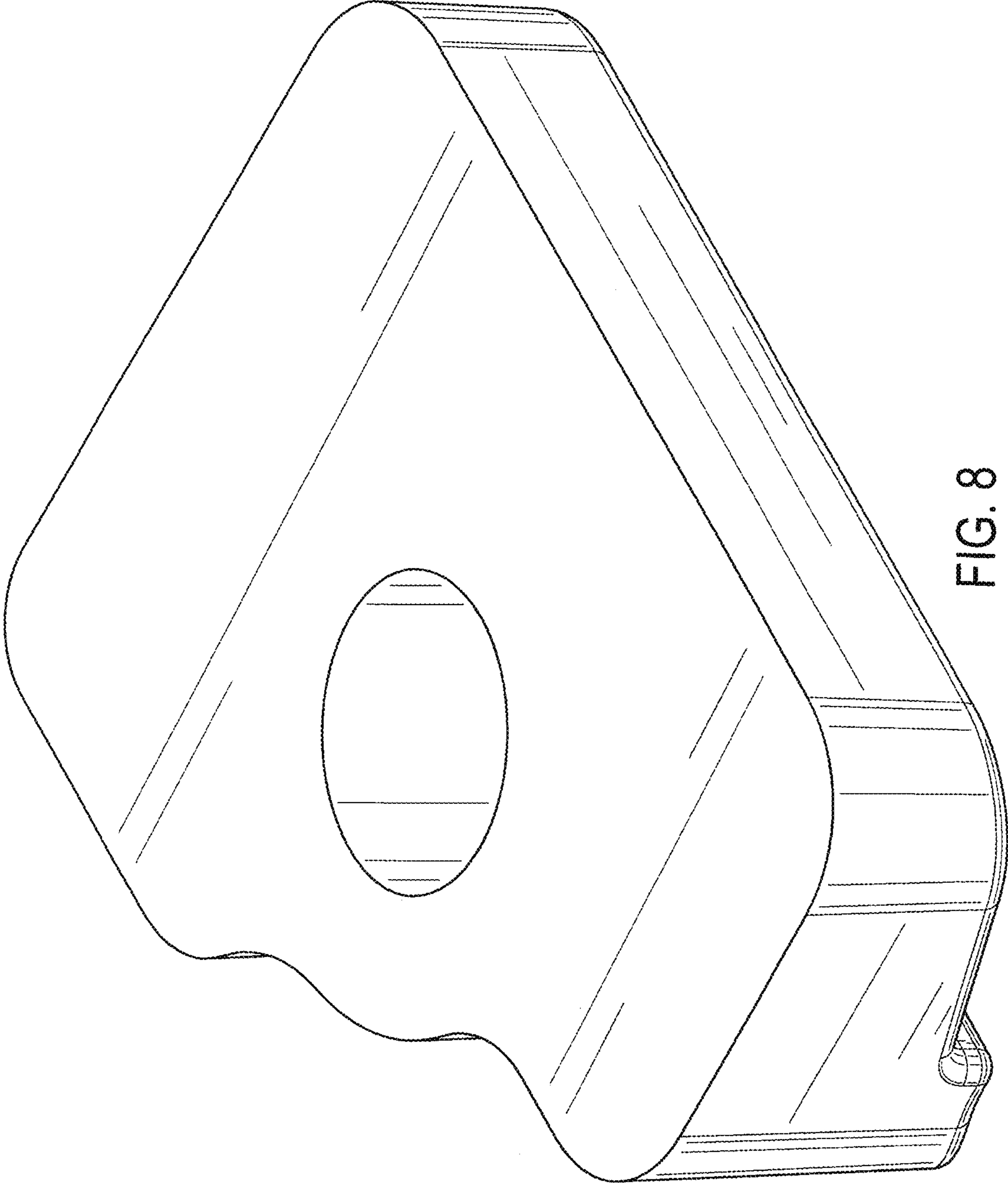

FIG. 8

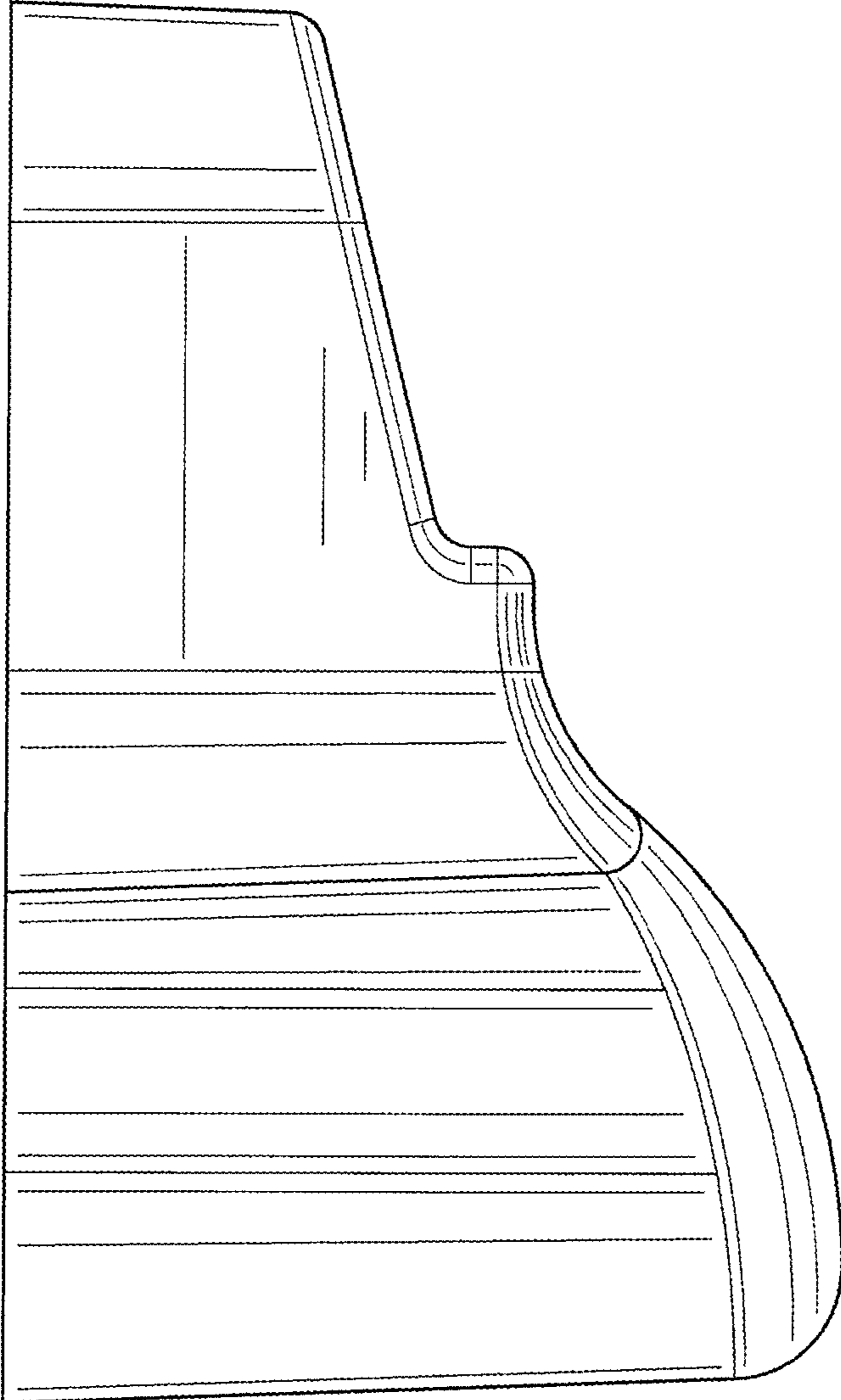

FIG. 9

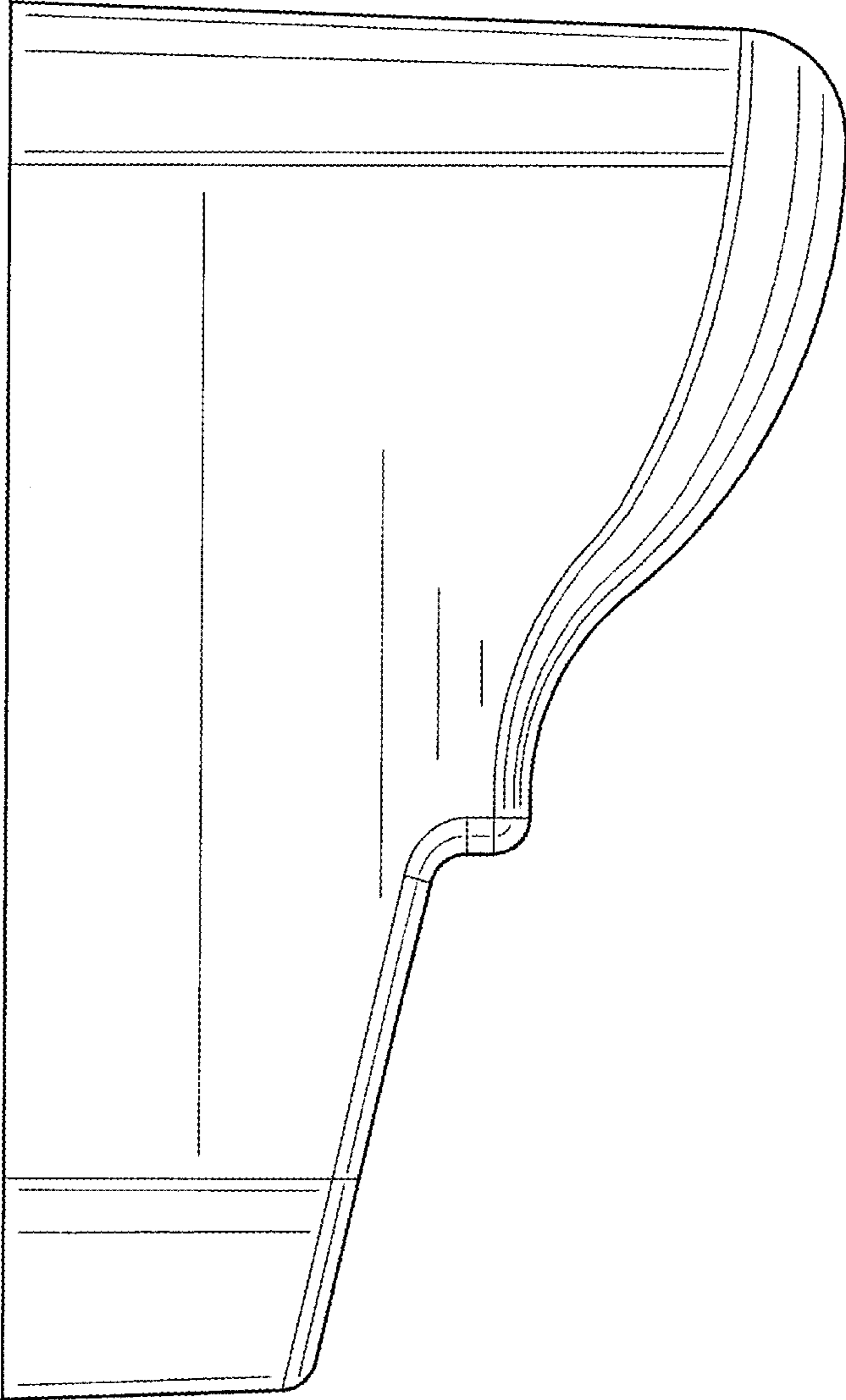

FIG. 10

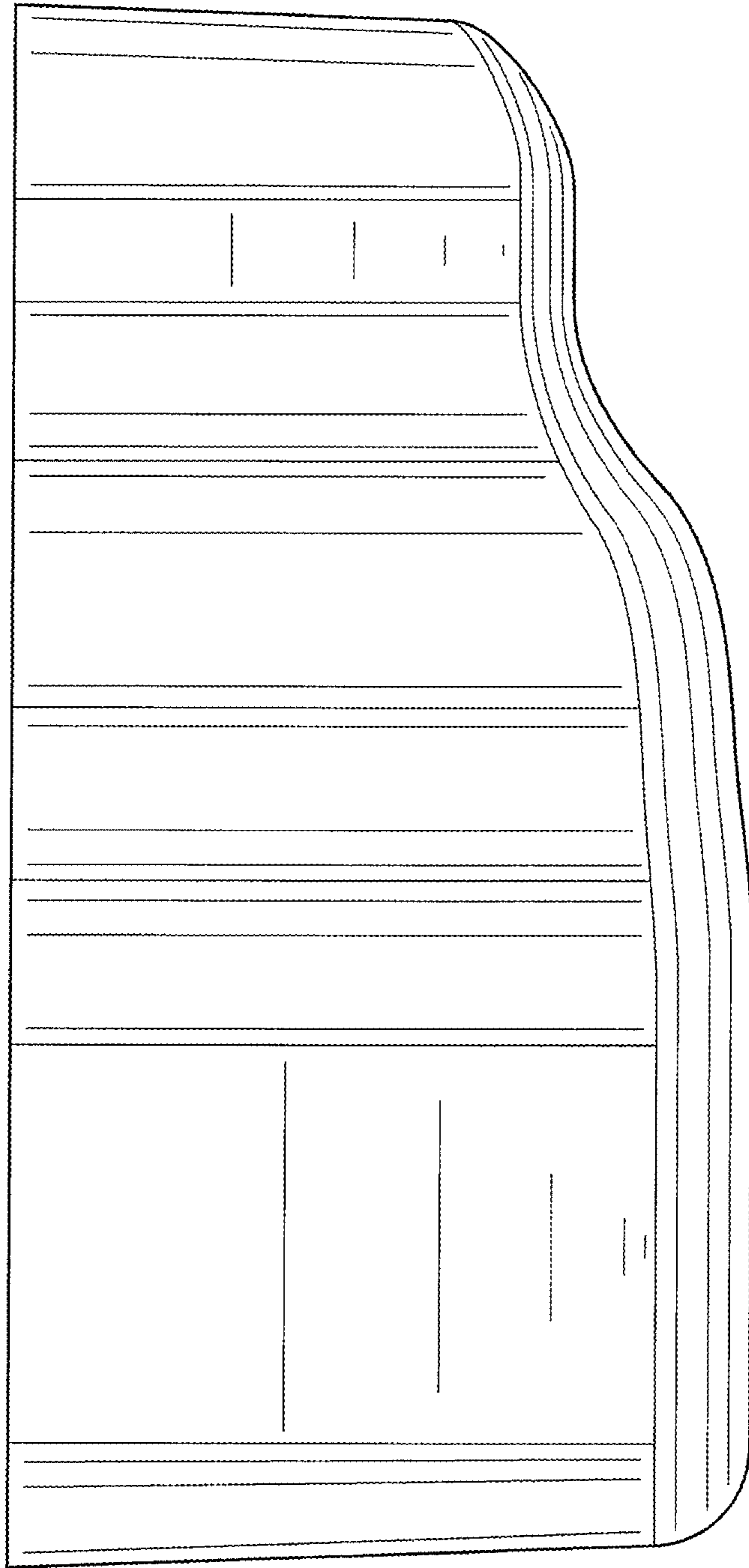

FIG. 11

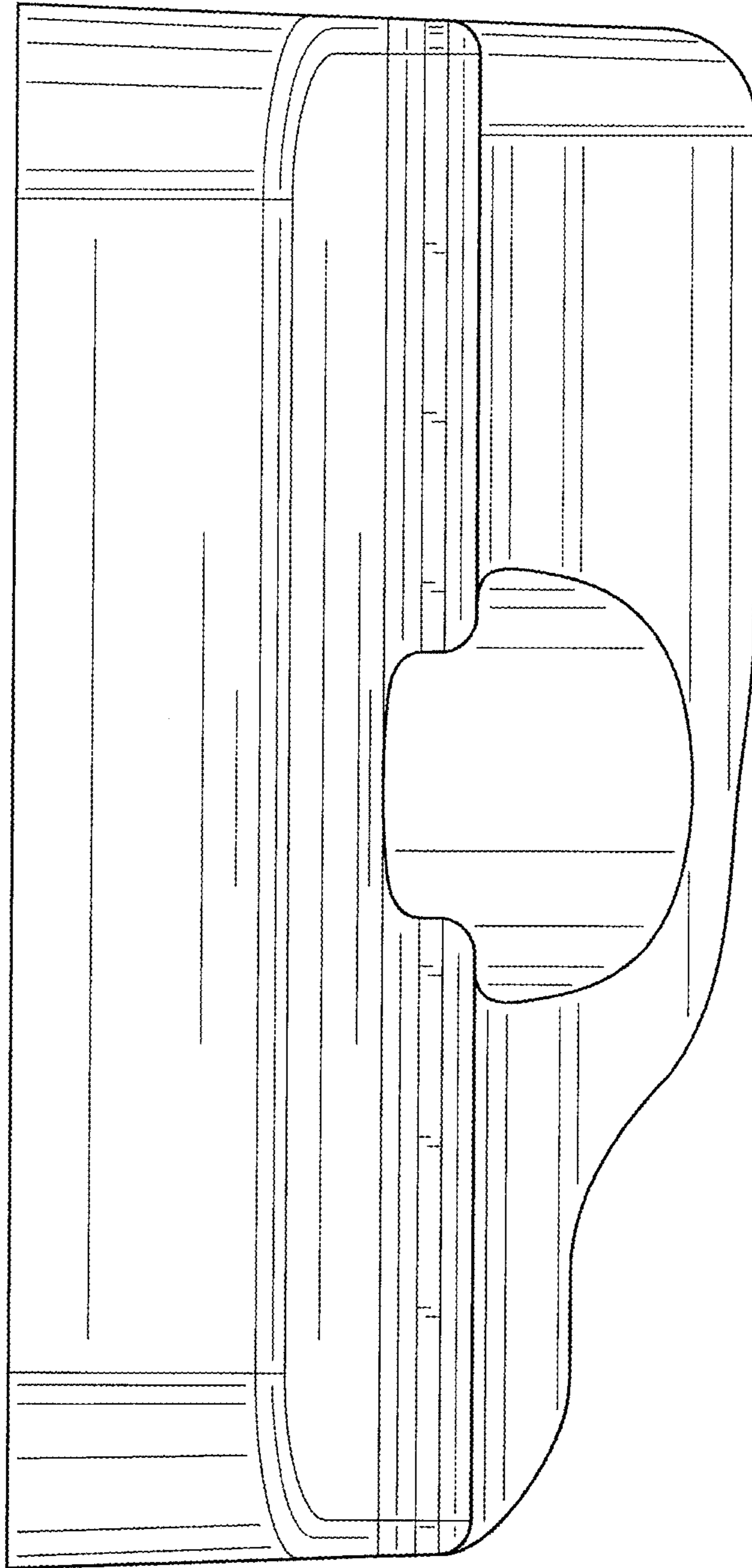

FIG. 12

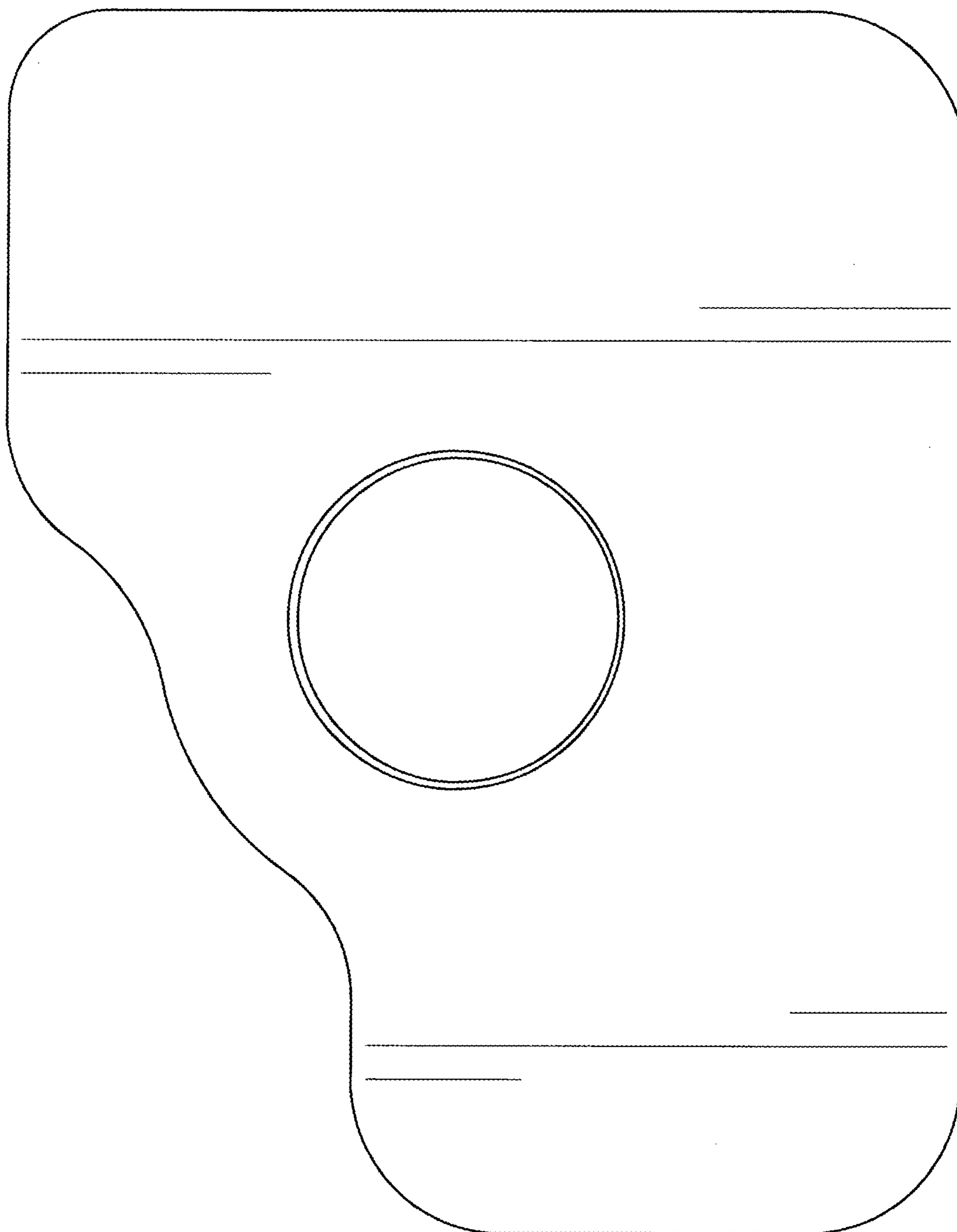

FIG. 13

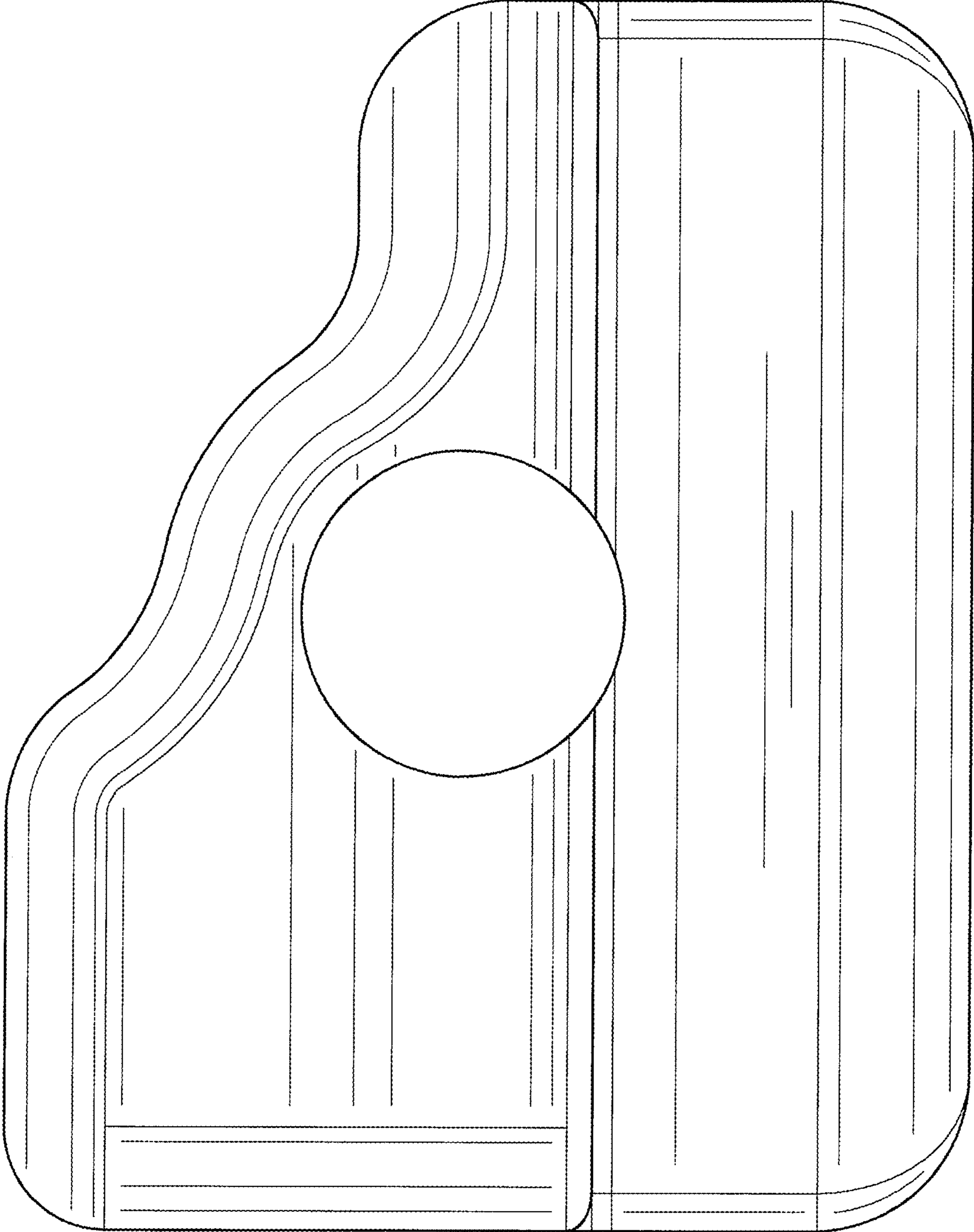

FIG. 14