



US00D885904S

(12) **United States Design Patent**
Kim

(10) **Patent No.:** **US D885,904 S**

(45) **Date of Patent:** **** Jun. 2, 2020**

(54) **VENTING CLOSURE**

(71) Applicant: **Silgan White Cap LLC**, Downers Grove, IL (US)

(72) Inventor: **Sungsuk Steve Kim**, Batavia, IL (US)

(73) Assignee: **Silgan White Cap LLC**, Downers Grove, IL (US)

(**) Term: **15 Years**

(21) Appl. No.: **29/650,931**

(22) Filed: **Jun. 11, 2018**

Related U.S. Application Data

(63) Continuation-in-part of application No. 29/646,077, filed on May 1, 2018, and a continuation-in-part of (Continued)

(51) **LOC (12) Cl.** **09-07**

(52) **U.S. Cl.**
USPC **D9/453**

(58) **Field of Classification Search**
USPC D3/202, 203.1, 203.2, 318; D7/300, D7/300.1, 316, 317, 323, 354, 387, 391, D7/392, 392.1, 396.1, 396.2, 397, 398, D7/503, 509, 510, 511, 523, 526-531, D7/538, 566, 568, 600.1, 602, 603, 614, D7/619.1, 629, 704, 900; D8/14, 14.1, D8/45; D9/434, 435, 440, 447, 452, 453, D9/499, 516, 529, 686, 723; D23/259, D23/260, 261; D24/121, 127, 199, 224
CPC B65D 2517/5091; B65D 41/04; B65D 23/12; B65D 1/0246; B65D 47/265; B65D 47/065; B65D 51/24; B65D 51/224; B65D 51/245; B65D 2101/0015; B65D 2251/0093; B65D 85/72; B65D 51/18; B65D 51/28; B65D 51/242; B65D 51/2814;

(Continued)

(56) **References Cited**

U.S. PATENT DOCUMENTS

D57,050 S 2/1921 Ingram

D57,054 S 2/1921 Ingram

(Continued)

OTHER PUBLICATIONS

38 MM Lead Bore Seal Cap: Announced Jul. 22, 2017 [online]. Site Visited [Aug. 2, 2019]. Available from Internet URL: http://plastics.silgan-closures.com/eu_en/product/311.*

(Continued)

Primary Examiner — Jennifer Rivard

Assistant Examiner — Catherine S Posthauer

(74) *Attorney, Agent, or Firm* — Reinhart Boerner Van Deuren s.c.

(57) **CLAIM**

I claim the ornamental design for a venting closure, as shown and described.

DESCRIPTION

FIG. 1 is a top perspective view of an embodiment of the claimed design;

FIG. 2 is a top view of FIG. 1;

FIG. 3 is a bottom view of FIG. 1;

FIG. 4 is a side view of FIG. 1;

FIG. 5 is a cross sectional view thereof, taken in the direction of line 5-5 on FIG. 2;

FIG. 6 is a top perspective view of another embodiment of the claimed design;

FIG. 7 is a top view of FIG. 6;

FIG. 8 is a bottom view of FIG. 6;

FIG. 9 is a side view of FIG. 6; and,

FIG. 10 is a cross sectional view thereof, taken in the direction of line 10-10 on FIG. 7.

The ornamental design which is claimed is shown in solid lines in the drawings.

1 Claim, 8 Drawing Sheets

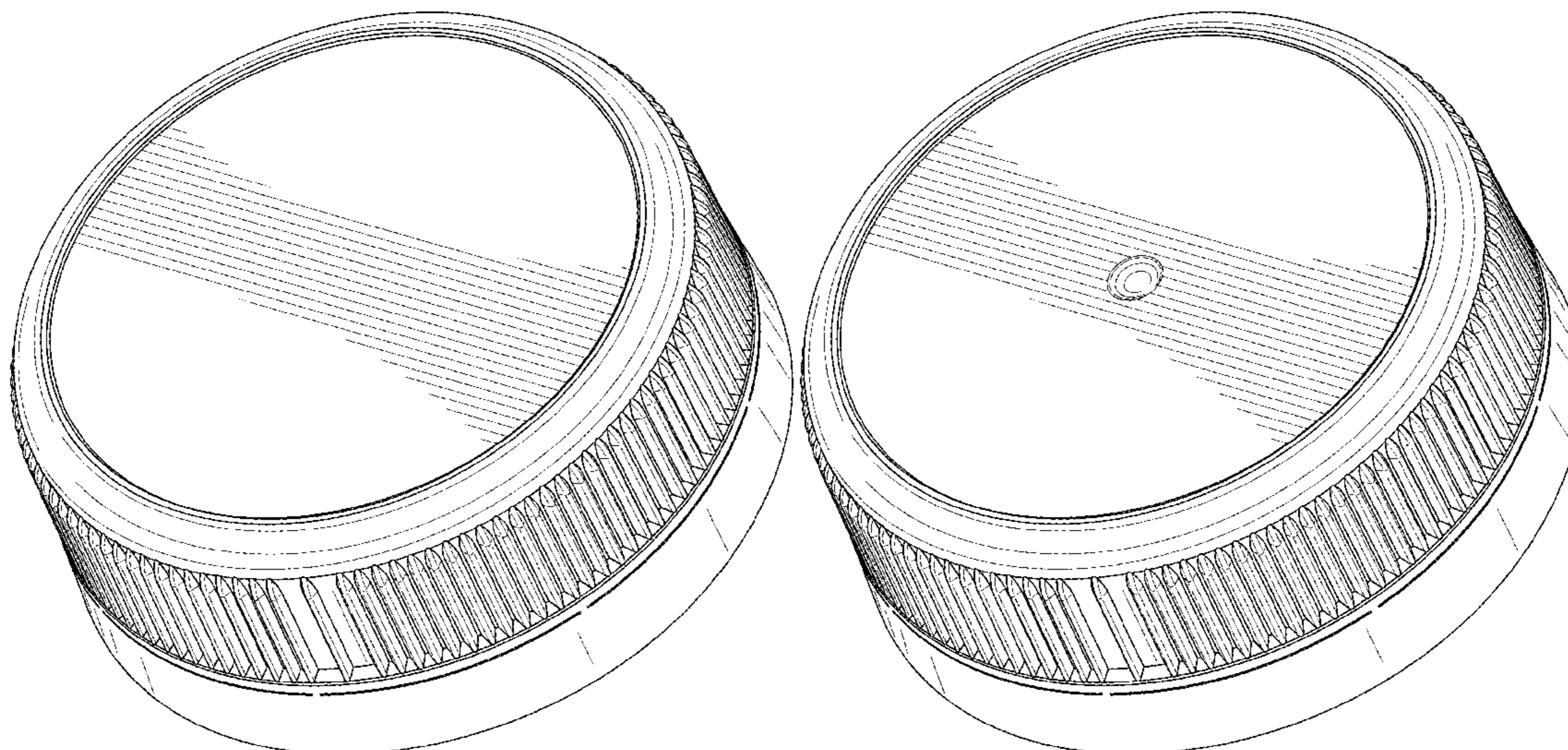

Related U.S. Application Data

application No. 15/968,313, filed on May 1, 2018, now abandoned.

(58) **Field of Classification Search**

CPC B65D 51/2821; B65D 21/0228; B65D 41/3447; B65D 1/02; A61L 9/12; A47G 19/2205; A47G 19/2222; A47G 19/2266; A47G 19/2272; A47G 19/2294; A47J 43/27; B05B 7/2437; B05C 17/00576

See application file for complete search history.

(56) **References Cited**

U.S. PATENT DOCUMENTS

1,495,324 A 5/1924 Hammer
D73,696 S 10/1927 Green
1,667,003 A 4/1928 Hardiman
D196,082 S 8/1963 Stull
3,812,994 A 5/1974 Feldman
4,981,230 A * 1/1991 Marshall B65D 41/3428
215/252
5,385,252 A * 1/1995 Hidding B65D 41/0421
215/230
D359,682 S 6/1995 Miller
5,487,481 A * 1/1996 Sander B65D 41/3447
215/252
5,673,809 A * 10/1997 Ohmi B65D 41/045
215/252
5,743,420 A 4/1998 Loffler et al.
5,913,437 A 6/1999 Ma
D443,513 S 6/2001 Goettner
D451,393 S * 12/2001 Gerhart D9/453
6,405,886 B1 * 6/2002 Gearhart B65D 41/3428
215/252
D460,357 S * 7/2002 Kras D9/435
D465,731 S * 11/2002 Brant D9/453
6,581,793 B1 6/2003 Racine et al.
D481,314 S * 10/2003 Noonan D9/438
6,677,397 B1 * 1/2004 Baranowski B65D 41/34
524/488
6,766,916 B2 * 7/2004 Ma B65D 41/3428
215/252
6,783,015 B1 8/2004 Bosl et al.
6,964,346 B1 * 11/2005 Taber B29C 45/0025
215/252
6,981,602 B2 * 1/2006 Ma B29C 43/42
215/254
D515,429 S 2/2006 Pace
D518,717 S 4/2006 German
D529,804 S * 10/2006 Lohrman D9/453
D534,802 S 1/2007 German
7,306,108 B2 12/2007 Cleevely
7,314,146 B2 1/2008 Mavin
D574,240 S * 8/2008 Szczesniak D9/453
7,413,097 B1 * 8/2008 Adams B65D 5/746
215/251
D578,889 S 10/2008 Sadiq
D583,237 S 12/2008 Fuchs
D606,401 S 12/2009 Kamath et al.
D606,864 S * 12/2009 Robinson D9/453
D632,958 S * 2/2011 Fuchs D9/453
D634,200 S * 3/2011 Taber D9/453

8,066,133 B2 11/2011 Takamatsu et al.
D687,299 S * 8/2013 Peykoff D9/453
D688,128 S * 8/2013 Krause B65D 41/0414
D9/453
D693,685 S * 11/2013 Ramsey D9/453
D723,370 S * 3/2015 Medlin D9/453
D723,919 S * 3/2015 Taber D9/438
D731,238 S * 6/2015 Kalaouze, Jr. D7/392.1
D762,115 S * 7/2016 Corvaglia D9/443
D789,201 S * 6/2017 Yu D9/453
D792,219 S * 7/2017 Bueno Nunez D9/453
D824,257 S * 7/2018 Wood D9/453
D836,442 S 12/2018 Wood et al.
D838,171 S * 1/2019 Wood D9/453
D863,963 S 10/2019 Berroa Garcia
2001/0027957 A1 10/2001 Kano
2002/0158037 A1 10/2002 Kano et al.
2003/0132244 A1 * 7/2003 Birkmayer B65D 41/3442
222/83
2007/0051690 A1 3/2007 Hidding
2008/0067142 A1 * 3/2008 Druitt B65D 41/04
215/324
2008/0087625 A1 * 4/2008 Kumata B65D 41/0485
215/252
2008/0173611 A1 * 7/2008 Neputy B65D 41/3423
215/256
2012/0031871 A1 * 2/2012 Molinaro B65D 1/023
215/44
2013/0205718 A1 8/2013 Kapolas
2013/0313218 A1 * 11/2013 Cox B65D 41/0485
215/246
2014/0158660 A1 * 6/2014 Wood B65D 41/0421
215/252
2014/0263335 A1 * 9/2014 Taber B65D 41/0421
220/276
2016/0332783 A1 * 11/2016 Kim B65D 41/34
2017/0021978 A1 1/2017 Keener
2017/0050350 A1 2/2017 Falzoni et al.
2018/0044079 A1 2/2018 Van de Grift et al.
2018/0057227 A1 * 3/2018 Bartow B65D 17/4012
2018/0079552 A1 3/2018 Ayeni
2018/0162605 A1 6/2018 Zeng et al.
2018/0370701 A1 12/2018 Maguire
2019/0009953 A1 * 1/2019 Edie B65D 41/3447
2019/0016510 A1 * 1/2019 Woodley B65D 50/043
2019/0062007 A1 * 2/2019 Kim B65D 41/0464
2019/0118989 A1 * 4/2019 Kim B65D 1/0246
2019/0337691 A1 11/2019 Kim
2019/0337692 A1 11/2019 Kim
2019/0344933 A1 11/2019 Kim

OTHER PUBLICATIONS

38 MM Lead Overcap: Announced Jul. 22, 2017 [online]. Site Visited [Aug. 2, 2019]. Available from Internet URL: http://plastics.silgan-closures.com/eu_en/product/313.
Turbosquid, "Plastics Bottle Screw Cap," Apr. 28, 2014, accessed on Internet Dec. 5, 2019, [<https://www.turbosquid.com/FullPreview/Index.cfm/ID/817447>], 1 page.
Silgan Closures, "38MM 3 Lead Wadded," Aug. 6, 2017, accessed on Internet Dec. 5, 2019, [http://plastics.silgan-closures.com/eu_en/product/310], 1 page.

* cited by examiner

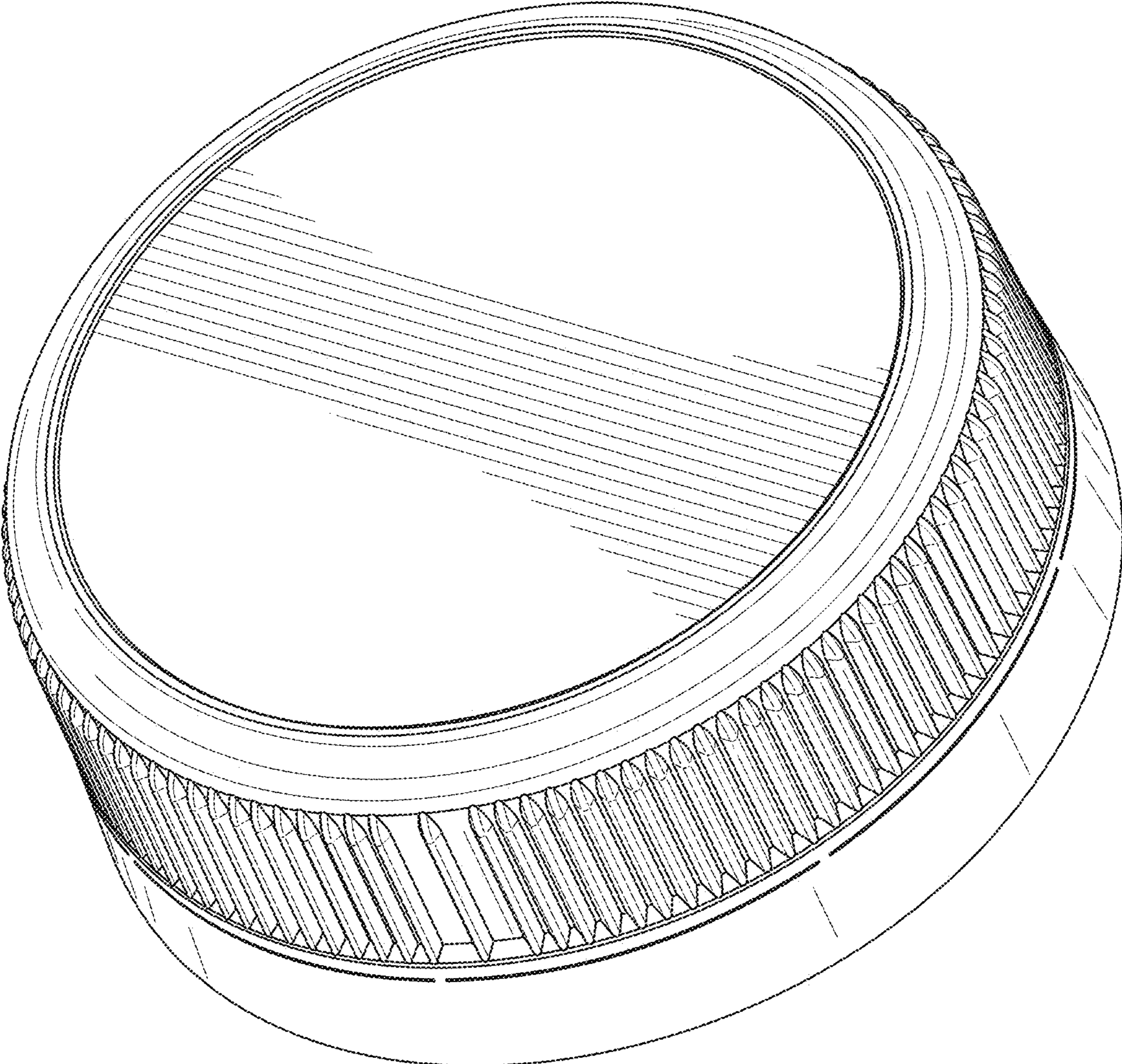

FIG. 1

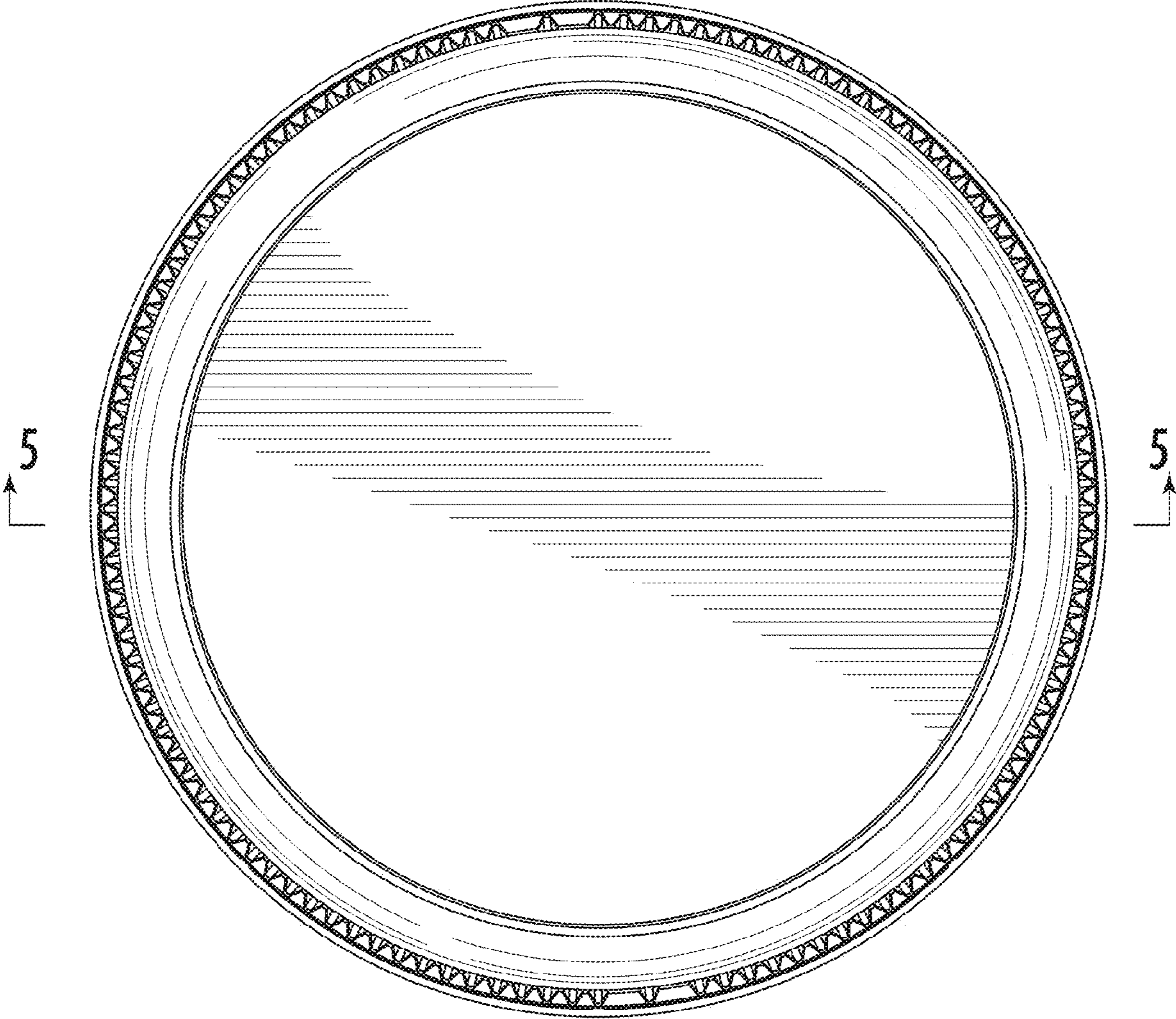

FIG. 2



FIG. 3

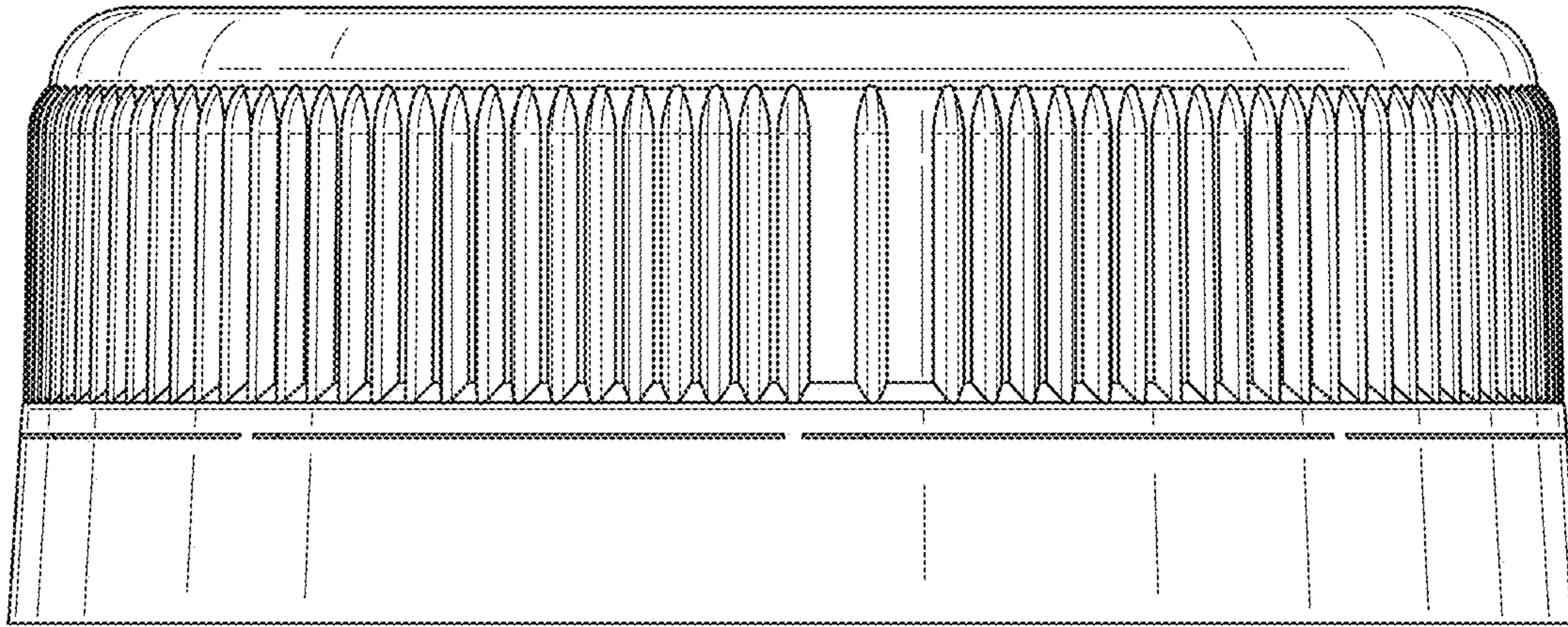

FIG. 4

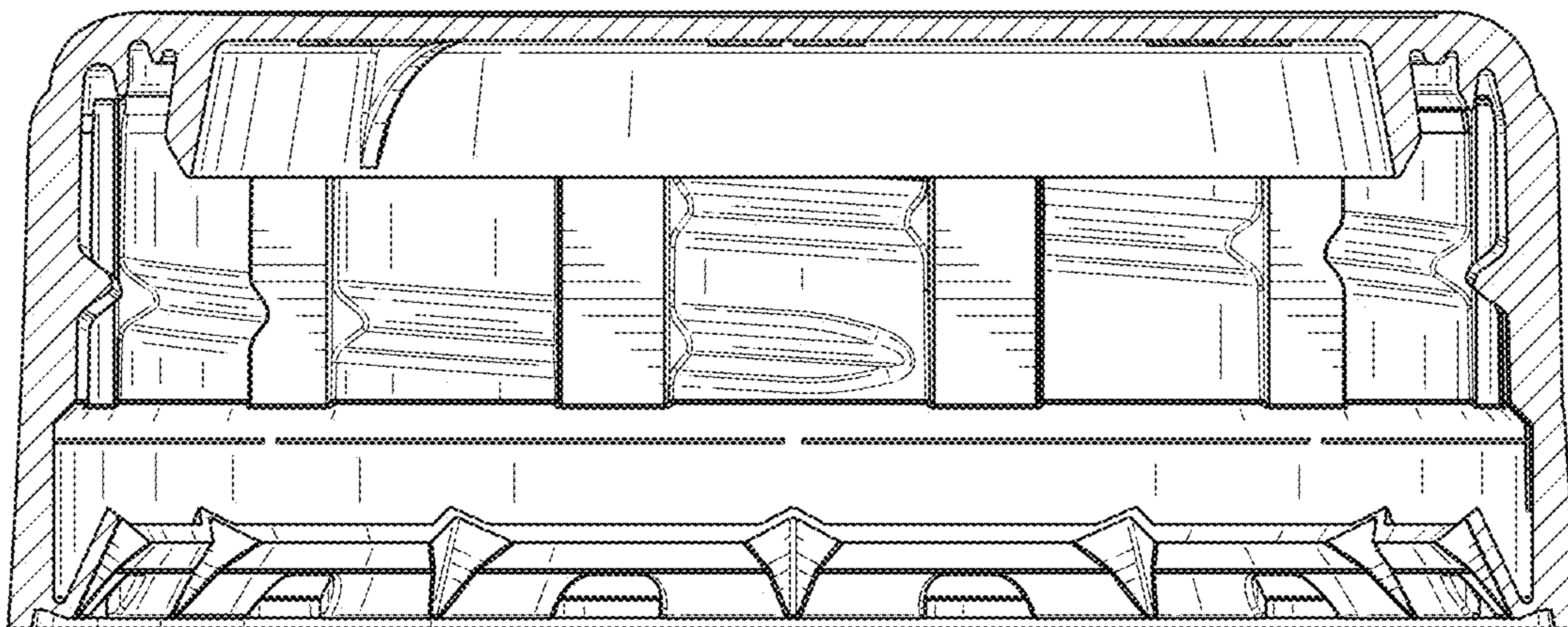

FIG. 5

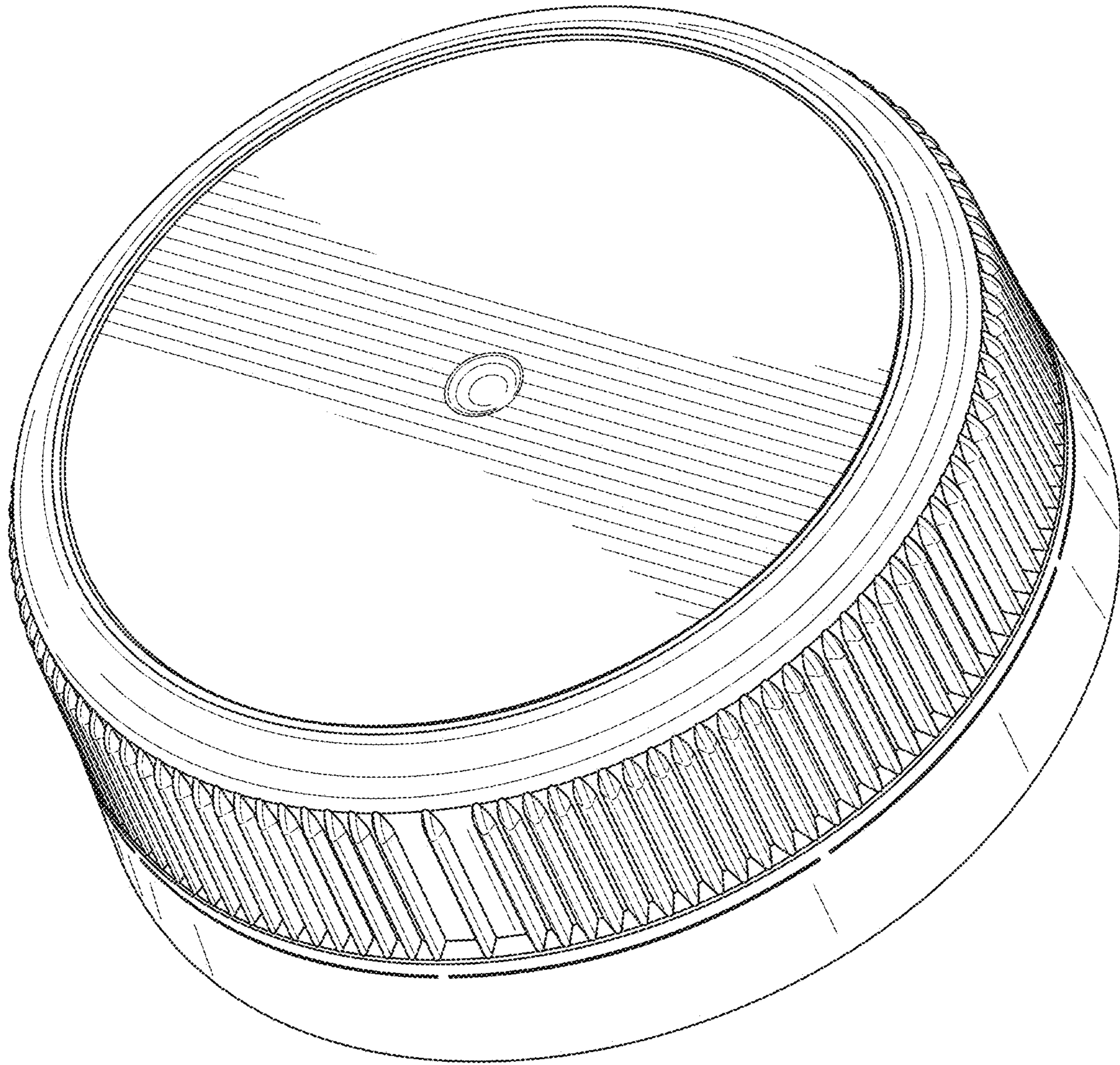

FIG. 6

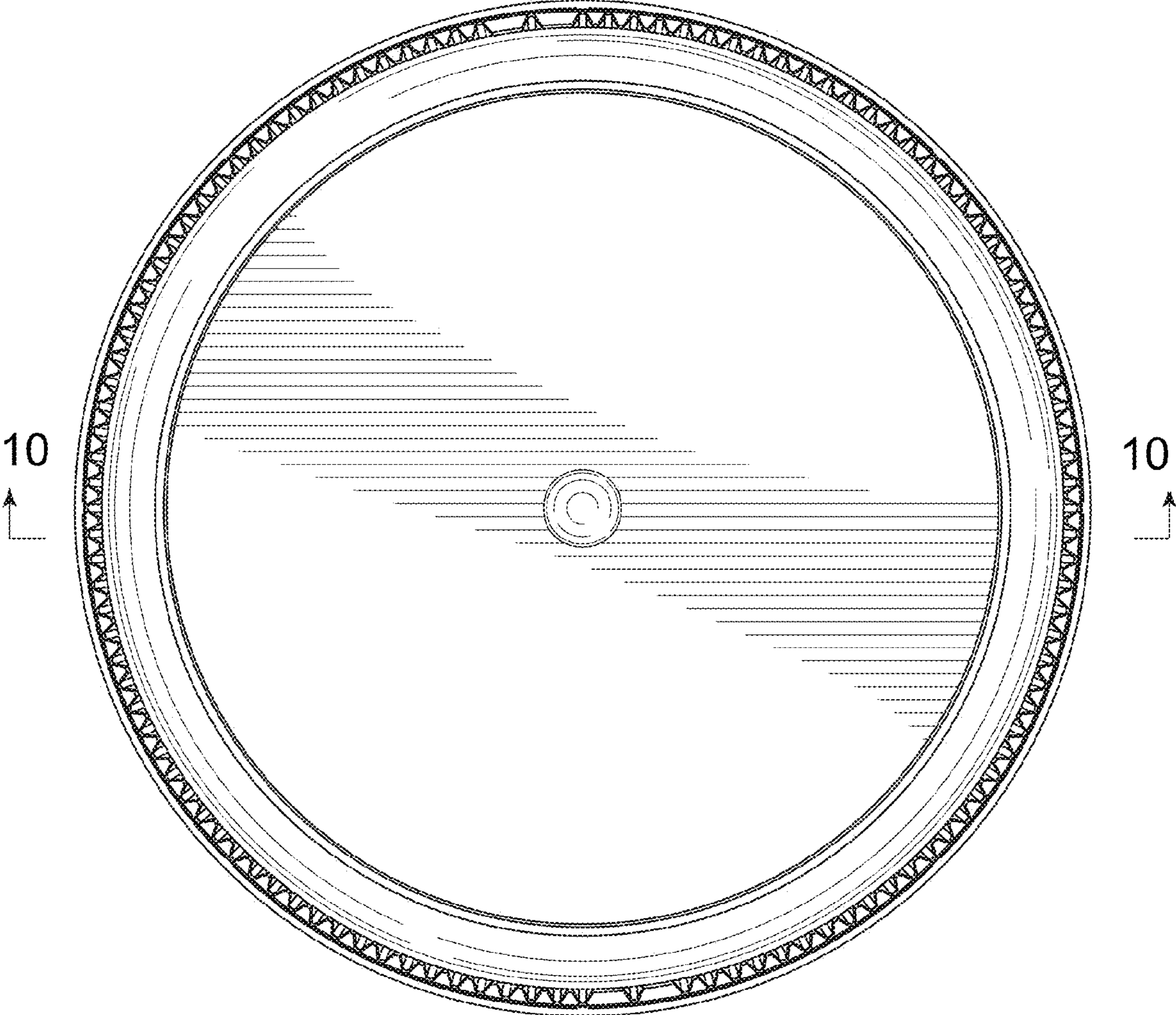

FIG. 7

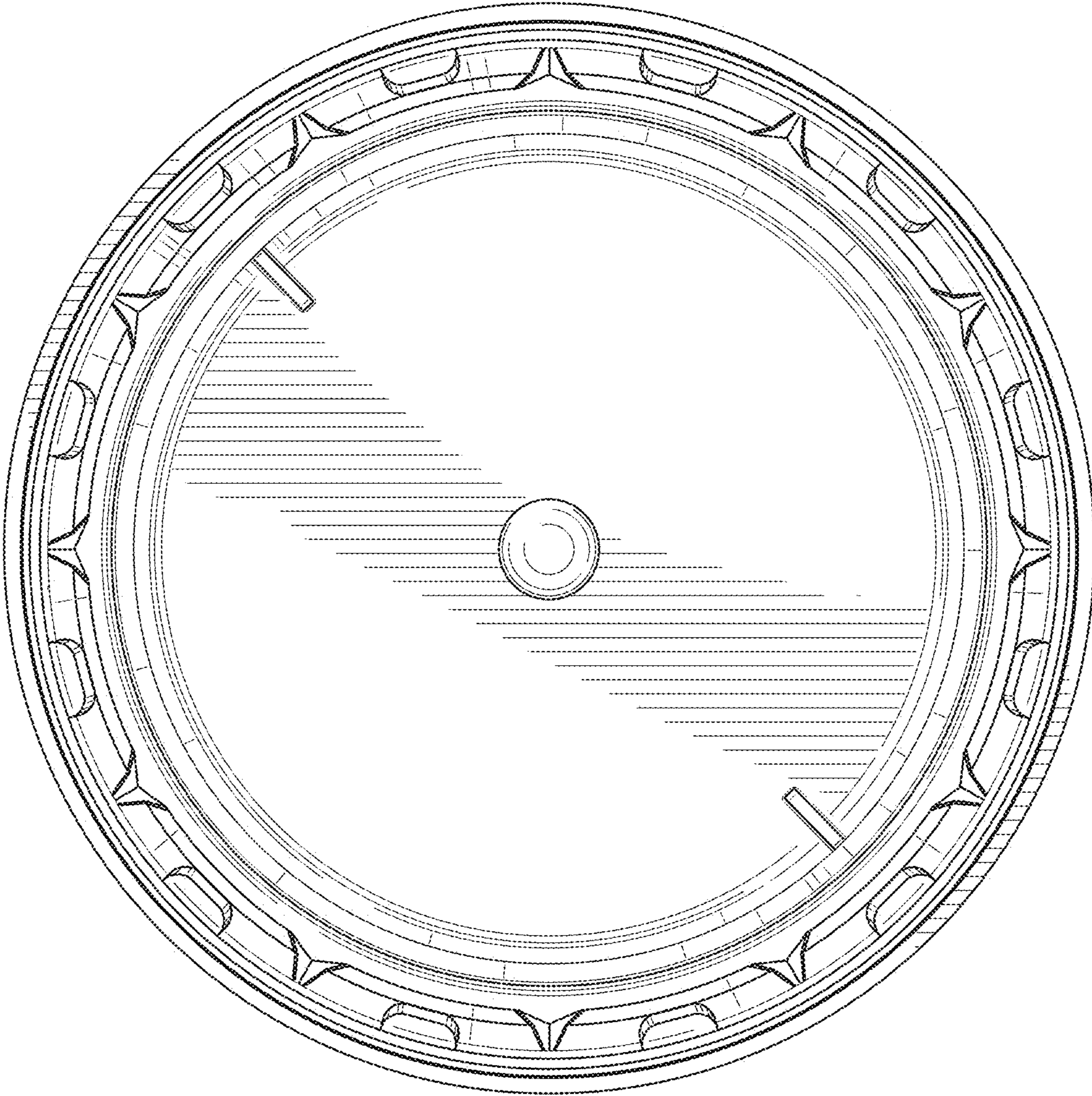

FIG. 8

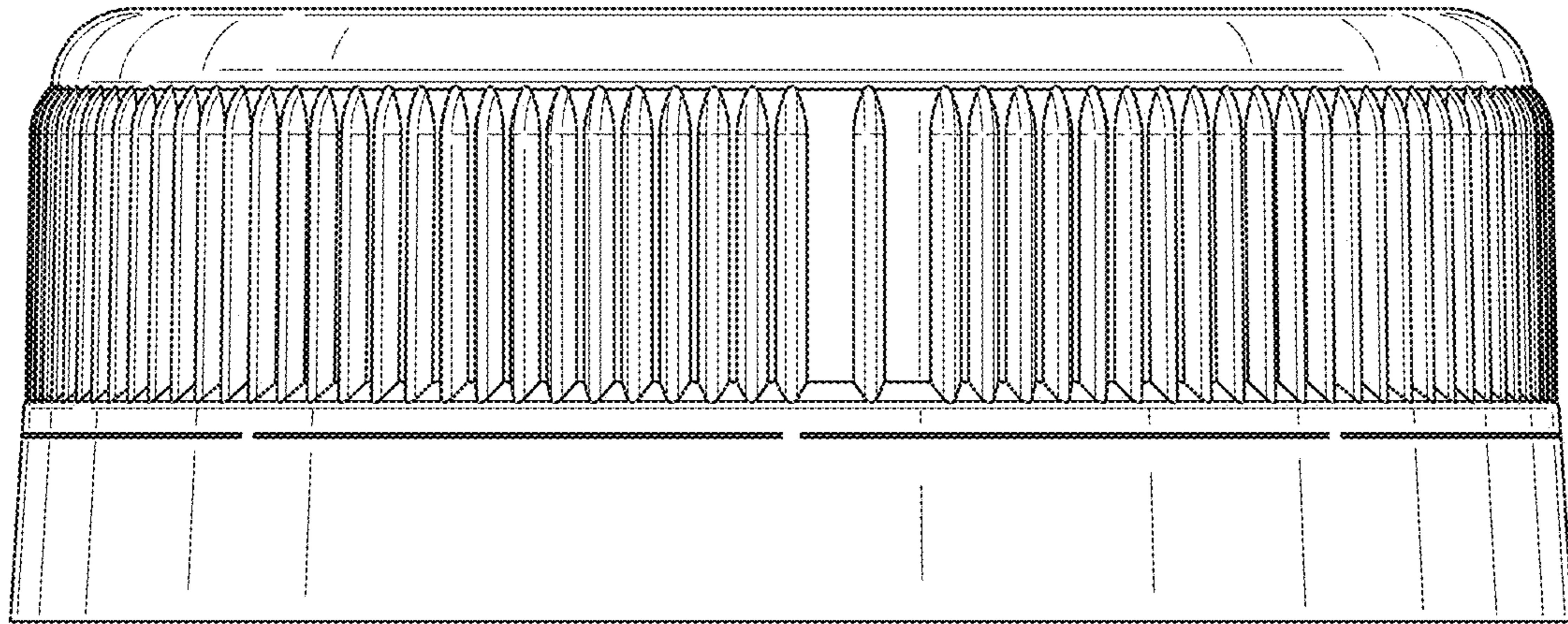

FIG. 9

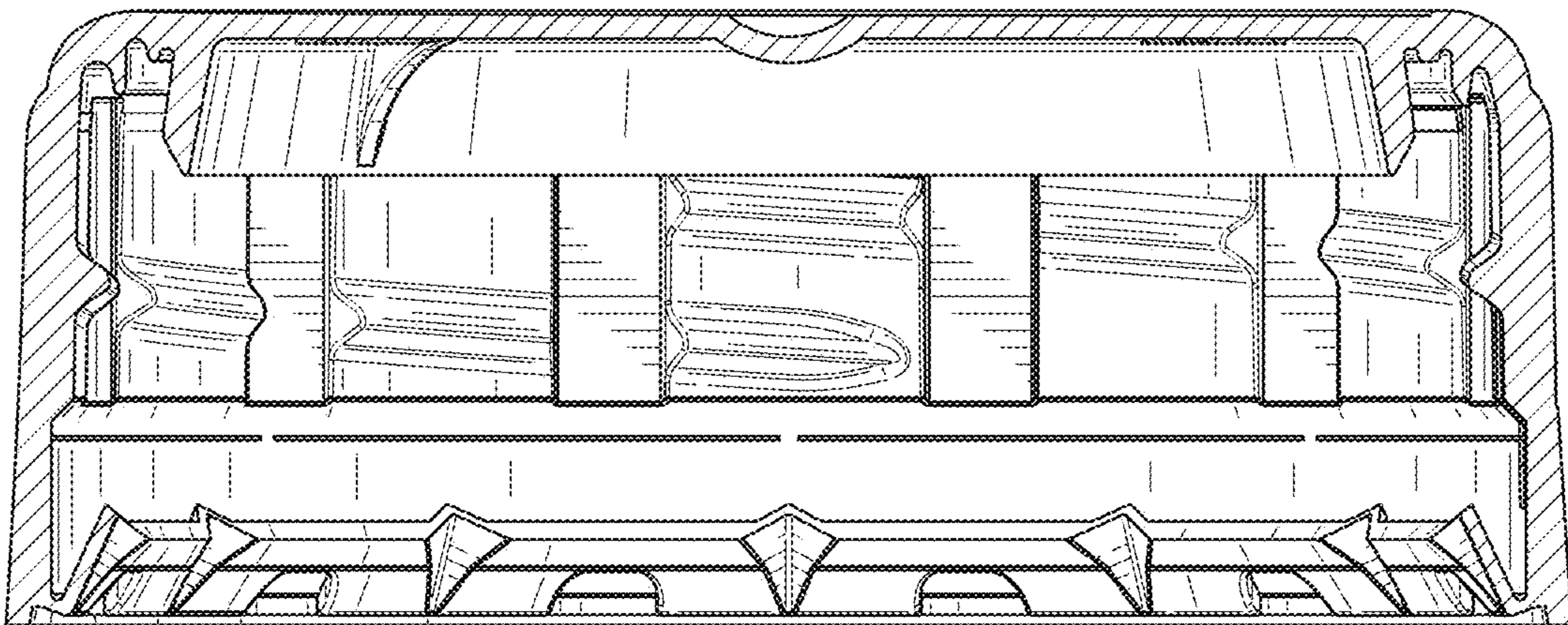

FIG. 10