



US00D885867S

(12) **United States Design Patent**
Chapman

(10) **Patent No.:** **US D885,867 S**
(45) **Date of Patent:** **** Jun. 2, 2020**

(54) **ADAPTOR**

(71) Applicant: **Topcon Positioning Systems, Inc.**,
Livermore, CA (US)

(72) Inventor: **Angus Chapman**, Brisbane (AU)

(73) Assignee: **Topcon Positioning Systems, Inc.**,
Livermore, CA (US)

(**) Term: **15 Years**

(21) Appl. No.: **29/675,183**

(22) Filed: **Dec. 28, 2018**

(51) **LOC (12) Cl.** **08-08**

(52) **U.S. Cl.**
USPC **D8/349**

(58) **Field of Classification Search**
USPC D8/349, 354, 355, 363, 373-377, 356,
D8/382; D12/317, 400, 415, 416
CPC .. A47F 5/00; A47H 1/10; A47G 29/00; A47G
29/08; A47B 97/00; A47K 3/14; H02J
7/0026; H02J 7/0021; H02J 7/0027;
Y02E 60/12; H01R 13/72; A61M 5/1418
See application file for complete search history.

(56) **References Cited**

U.S. PATENT DOCUMENTS

4,315,594 A	2/1982	Niederost	
D316,713 S *	5/1991	Sun Kag	D14/484
D363,930 S *	11/1995	Bailey	D14/484
6,598,835 B2 *	7/2003	Minnick	F16L 5/00 248/56
7,114,388 B1	10/2006	French et al.	
D594,399 S *	6/2009	Johnson	D12/400
D598,480 S *	8/2009	Kanemitsu	D15/148
D623,500 S	9/2010	Langner et al.	
D661,980 S *	6/2012	Rocquet	D8/374
D673,029 S	12/2012	Apesteguia et al.	
D695,591 S	12/2013	Ackerman et al.	
D716,640 S *	11/2014	Martinson	D8/356
D732,926 S	6/2015	Booth et al.	

D744,316 S	12/2015	Nook et al.	
D745,369 S	12/2015	Tungesvick	
D755,705 S *	5/2016	Shin	D12/400
D757,520 S	5/2016	Pratt	
9,354,158 B1	5/2016	Van Dijk et al.	
D766,069 S	9/2016	Miller	

(Continued)

FOREIGN PATENT DOCUMENTS

EP	0014251 A1	8/1980
EP	2840559 A1	2/2015
EP	3270117 A1	1/2018

OTHER PUBLICATIONS

Notice of Allowance dated Feb. 6, 2020, in connection with U.S.
Appl. No. 29/675,179, filed Dec. 28, 2018, 9 pgs.

(Continued)

Primary Examiner — Mark A Goodwin
Assistant Examiner — Benjamin M Weeks
(74) *Attorney, Agent, or Firm* — Chiesa Shahinian &
Giantomasi PC

(57) **CLAIM**

The ornamental design for an adaptor, as shown and
described.

DESCRIPTION

FIG. 1 is a front perspective view of an adaptor according to
our design;
FIG. 2 is a front view thereof;
FIG. 3 is a rear view thereof;
FIG. 4 is a left side view thereof;
FIG. 5 is a right side view thereof;
FIG. 6 is a top view thereof; and,
FIG. 7 is a bottom view thereof.
The broken lines shown in the drawing depict portions of the
adaptor that form no part of the claimed design.

1 Claim, 5 Drawing Sheets

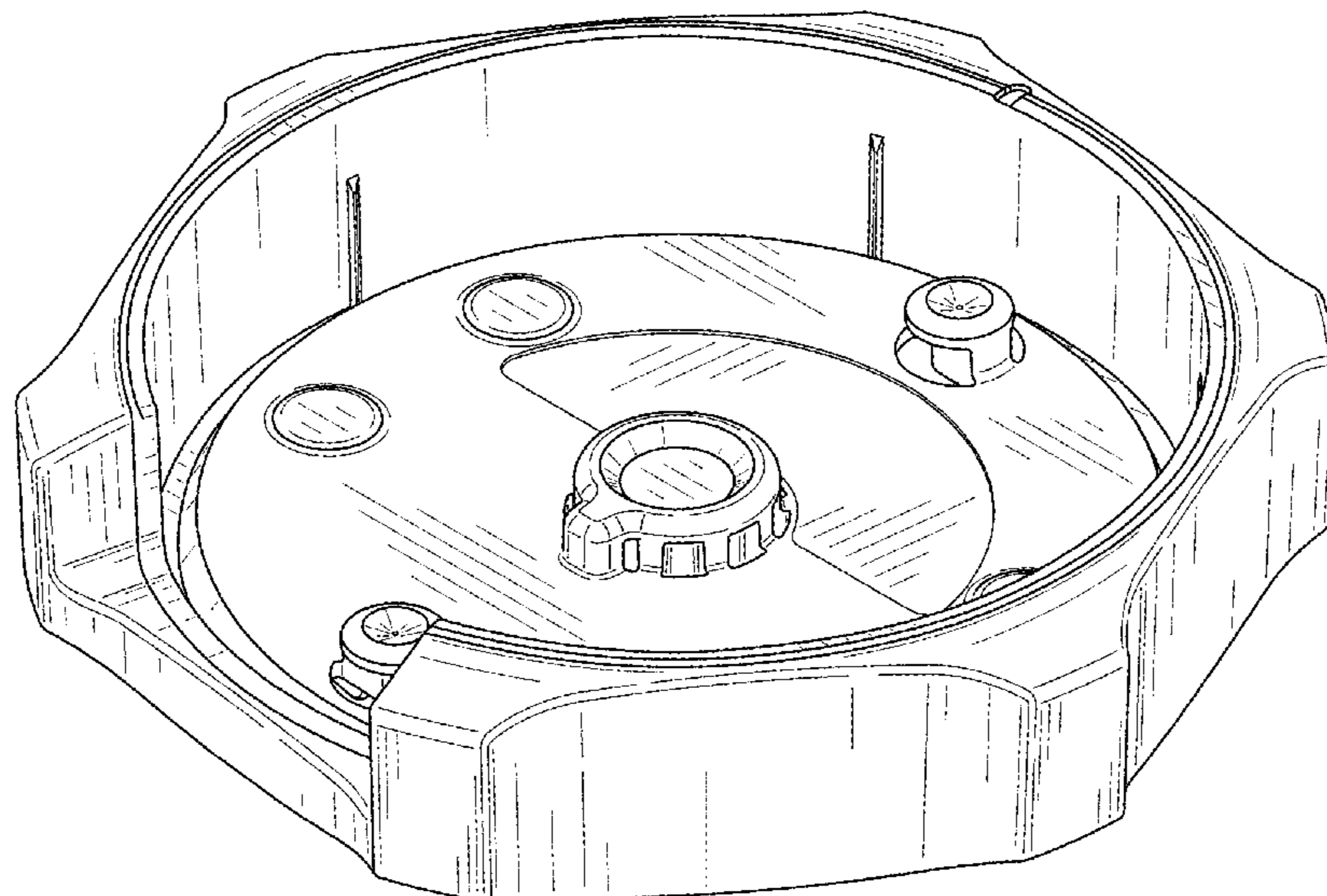

(56)

References Cited

U.S. PATENT DOCUMENTS

D767,218	S	9/2016	Hickling	
D779,921	S	2/2017	Del Rossa	
D779,922	S	2/2017	Del Rossa	
D803,908	S	11/2017	Yamaguchi et al.	
D822,081	S	7/2018	Yamaguchi et al.	
D831,467	S *	10/2018	Crichton	D8/356
D834,922	S *	12/2018	Russo	D8/355
D838,581	S *	1/2019	Huang	D8/382
D859,968	S *	9/2019	West	D8/382
D860,765	S *	9/2019	Tsay	D8/356
D863,936	S	10/2019	Pratt et al.	
D871,894	S *	1/2020	Brett	D8/356
2003/0056868	A1 *	3/2003	Gentry	B60C 27/10 152/217
2003/0137658	A1	7/2003	Ohtomo et al.	
2016/0180999	A1	6/2016	Rattner et al.	
2018/0017414	A1	1/2018	Binder et al.	

OTHER PUBLICATIONS

Non-Final Office Action dated Mar. 6, 2020, in connection with U.S. Appl. No. 16/235,622, filed Dec. 28, 2018, 16 pgs.
International Search Report dated Mar. 16, 2020, in connection with International Patent Application No. PCT/US2019/062319, filed Nov. 20, 2019, 18 pgs.

* cited by examiner

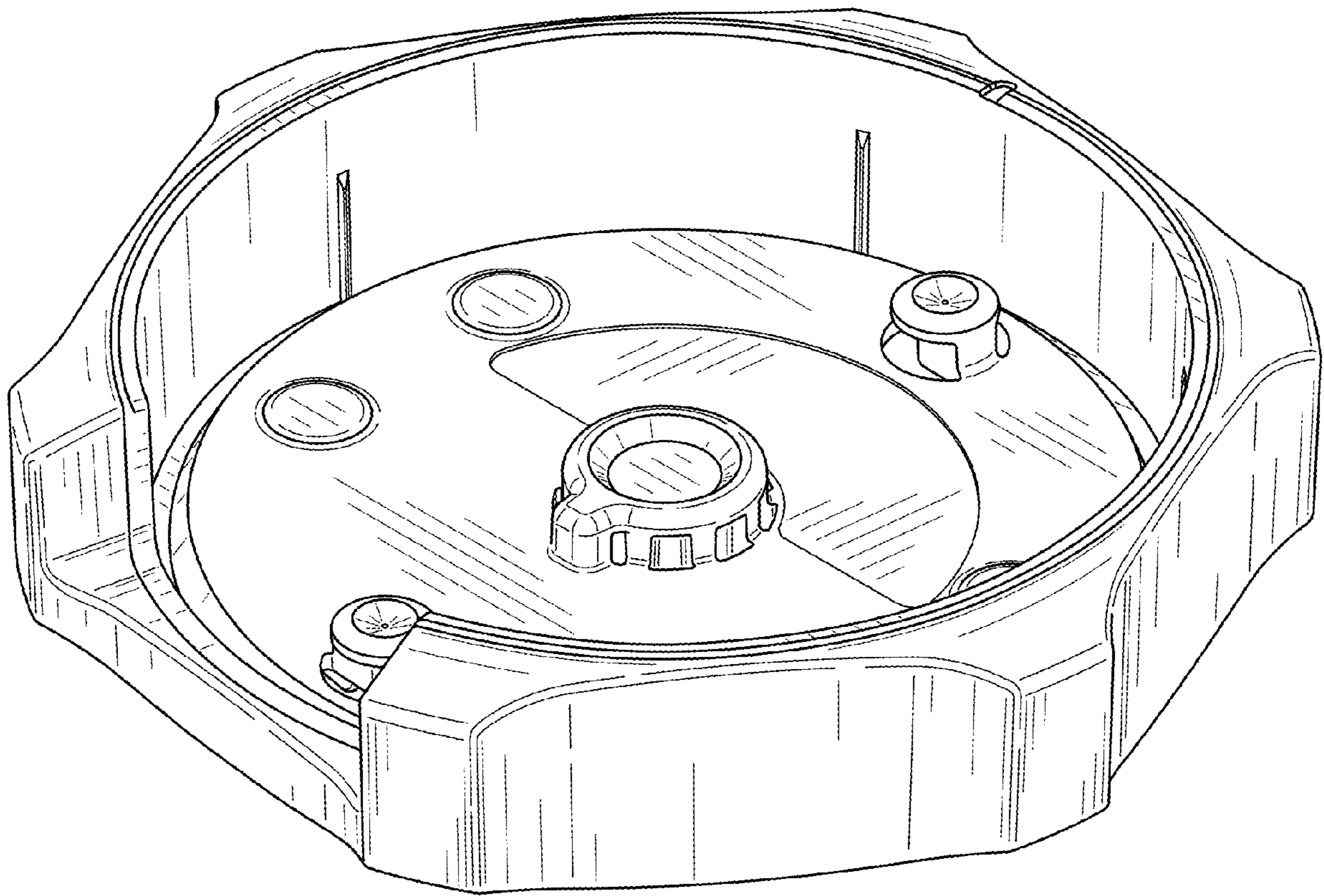

FIG. 1

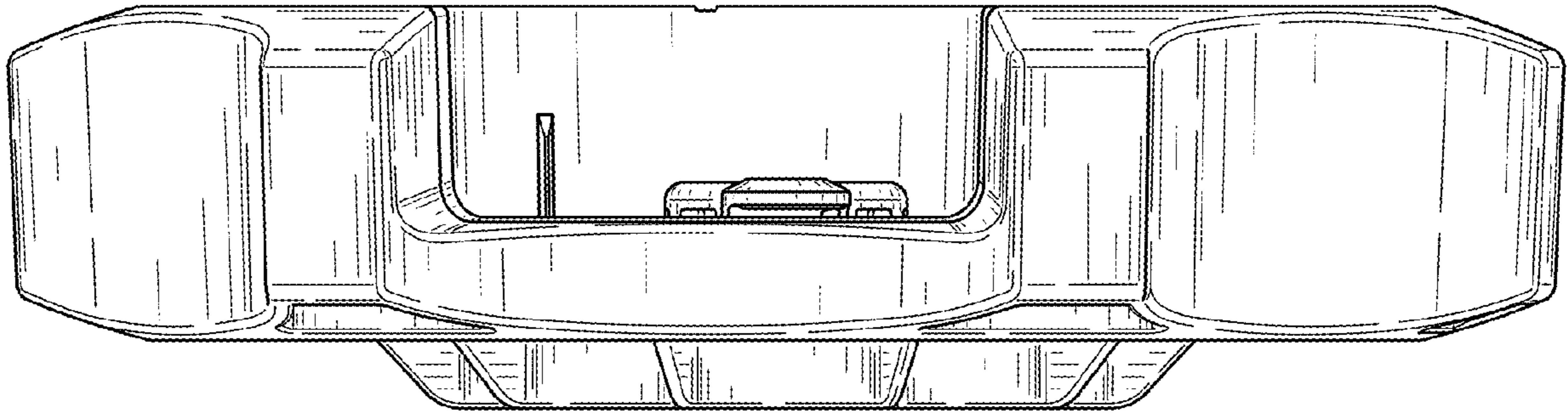

FIG. 2

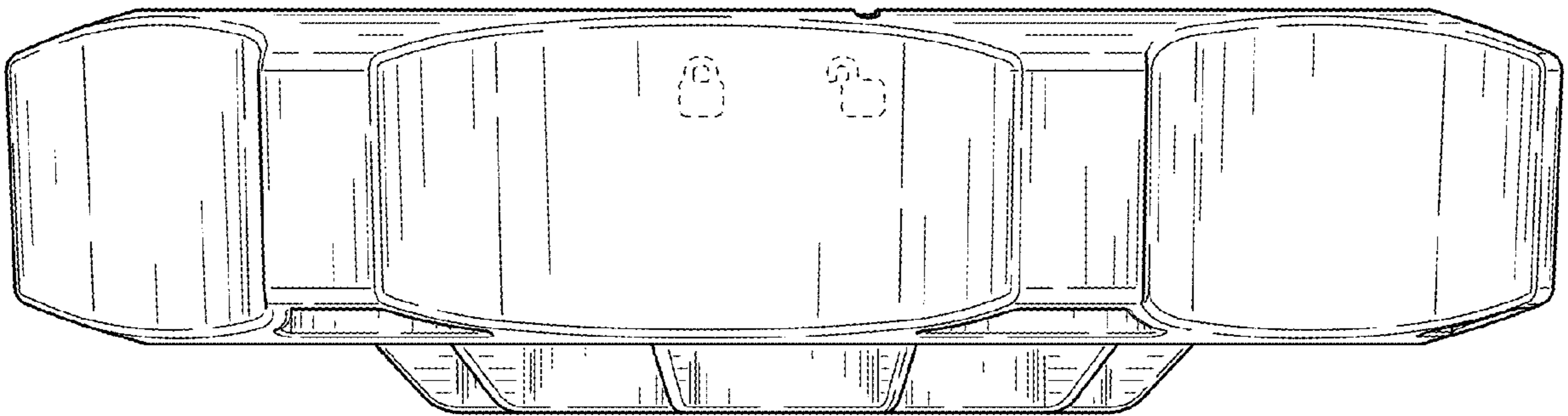

FIG. 3

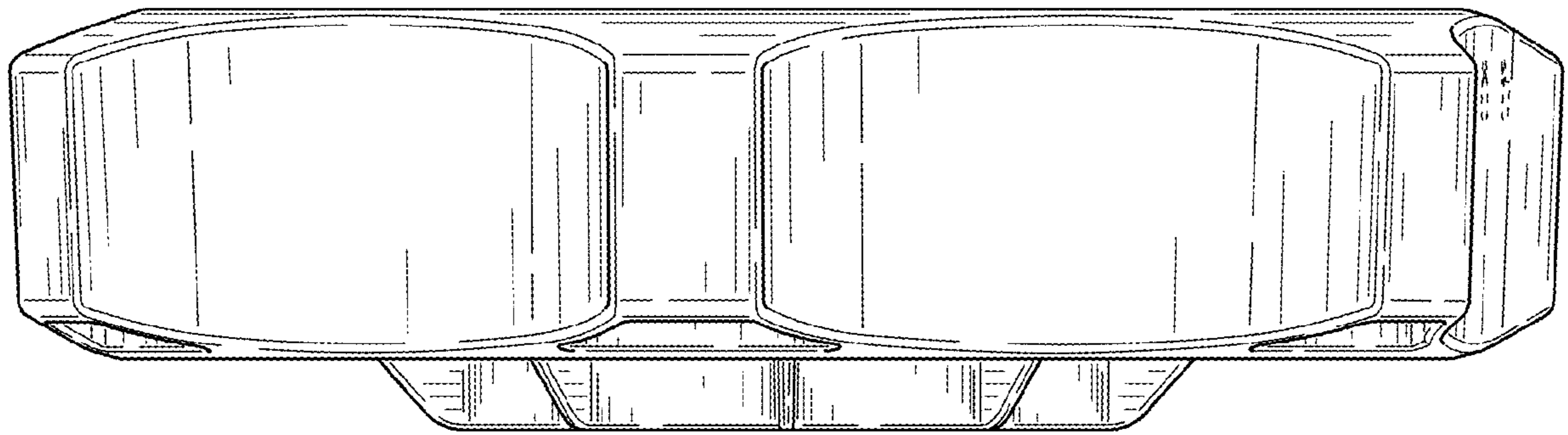

FIG. 4

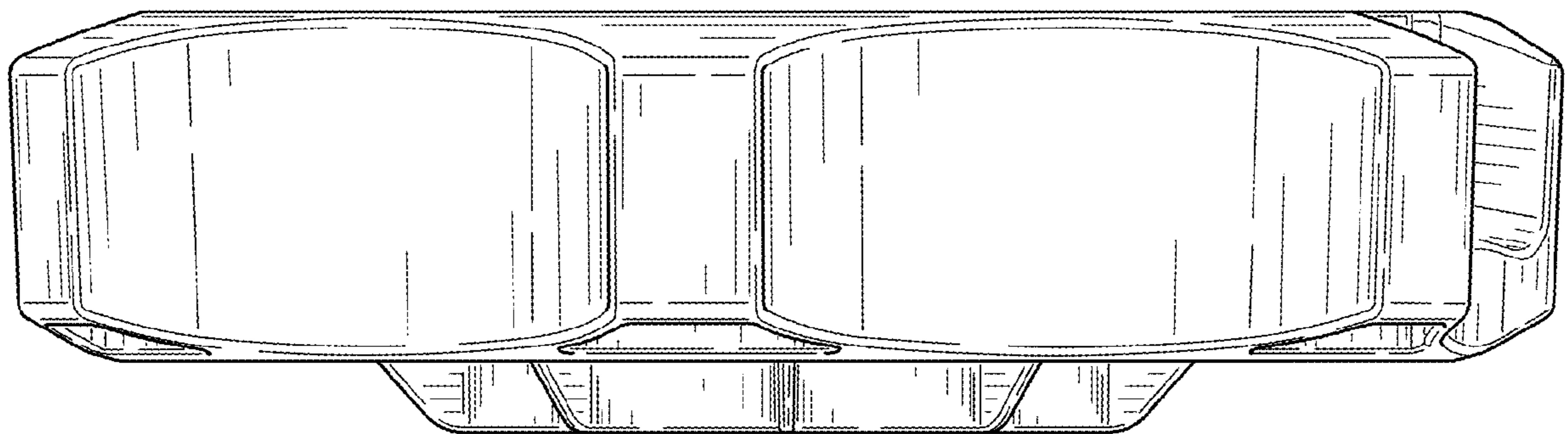

FIG. 5

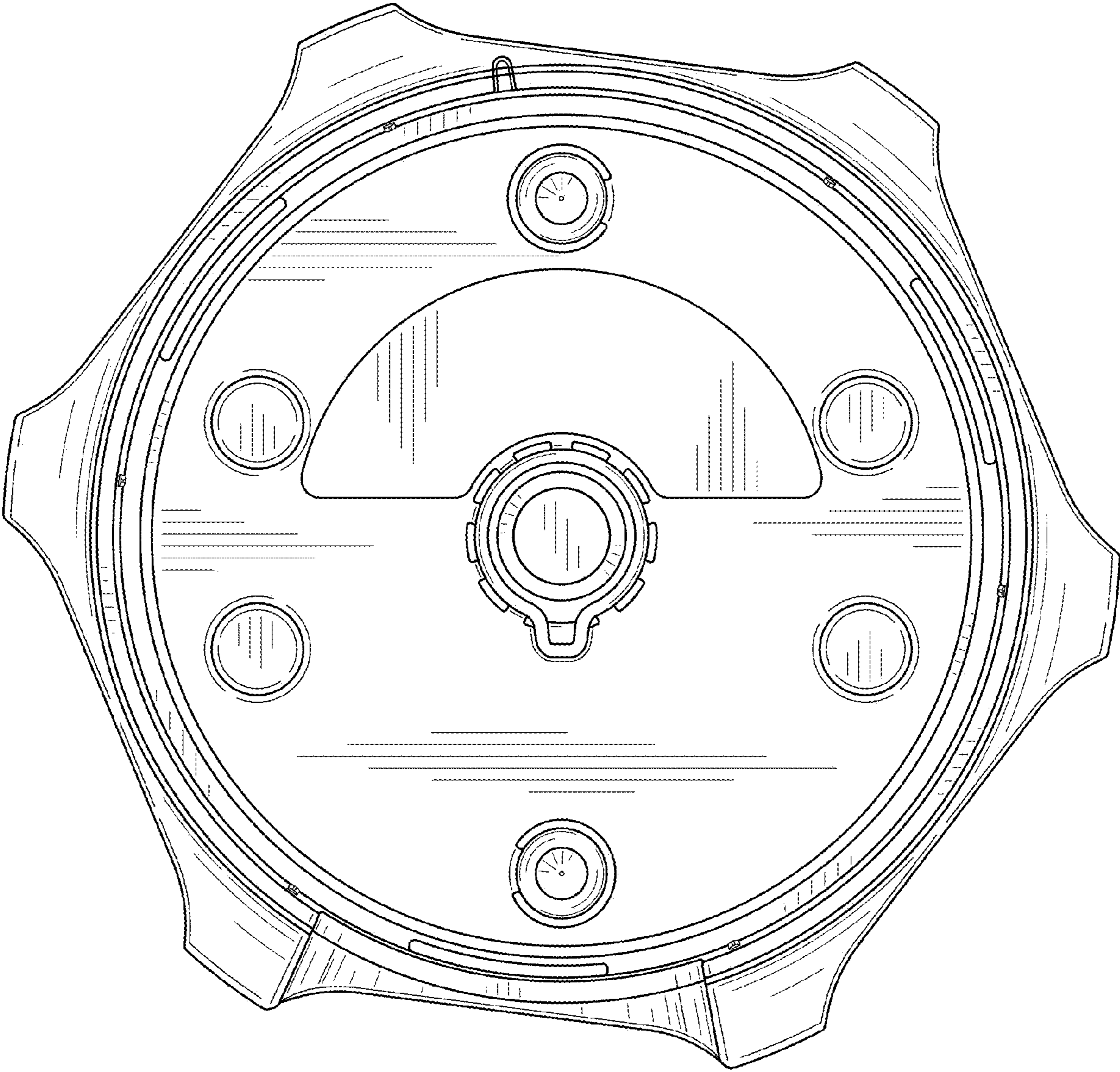

FIG. 6

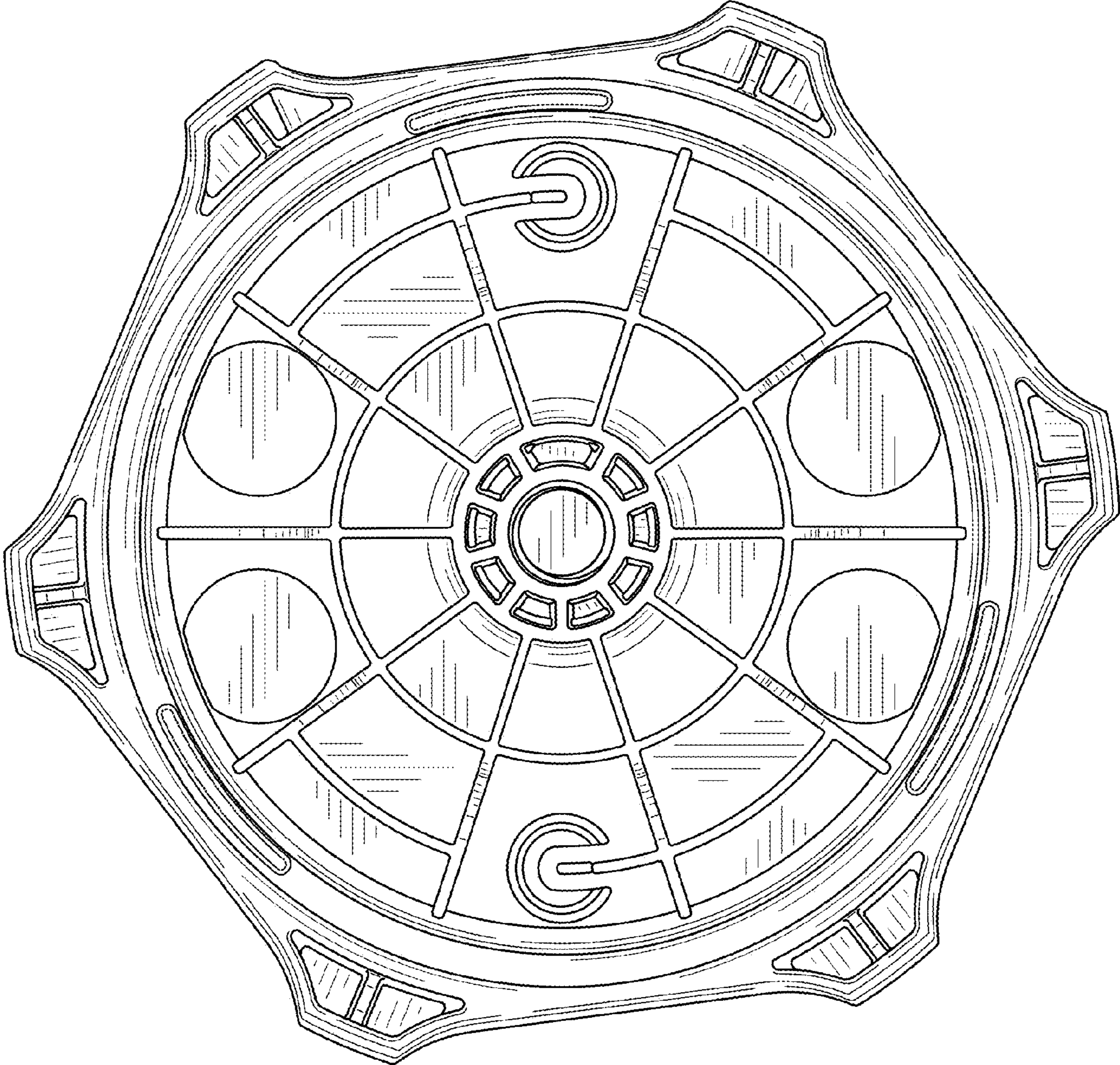

FIG. 7