



US00D885861S

(12) **United States Design Patent** (10) **Patent No.:** **US D885,861 S**
Ni (45) **Date of Patent:** **** Jun. 2, 2020**

(54) **CABLE TIE TOOL**
(71) Applicant: **HUA WEI INDUSTRIAL CO., LTD.,**
Taichung (TW)
(72) Inventor: **Wei Chieh Ni, Taichung (TW)**
(73) Assignee: **HUA WEI INDUSTRIAL CO., LTD.,**
Taichung (TW)
(**) Term: **15 Years**
(21) Appl. No.: **29/673,272**
(22) Filed: **Dec. 13, 2018**
(51) **LOC (12) Cl.** **08-05**
(52) **U.S. Cl.**
USPC **D8/44; D8/51**
(58) **Field of Classification Search**
USPC D8/14, 44, 51, 67, 68
CPC B21F 9/02; B25B 25/005; B65B 13/027;
B65B 13/22; B65B 13/345
See application file for complete search history.

7,216,679 B2 * 5/2007 Magno, Jr. B65B 13/027
140/123.6
7,231,944 B2 * 6/2007 Magno, Jr. B65B 13/027
140/123.6
D547,626 S * 7/2007 Lueschen D8/44
7,299,830 B2 * 11/2007 Levin B65B 13/027
140/123.6
D692,738 S * 11/2013 Dyer D8/44
D758,155 S * 6/2016 Kruzel D8/44
9,481,102 B1 * 11/2016 Hojnacki B26D 7/0006
D818,787 S * 5/2018 Kitago D8/44
2005/0178460 A1 * 8/2005 Magno, Jr. B23Q 17/00
140/123.6
2013/0167970 A1 * 7/2013 Dyer B26D 7/14
140/123.6
2016/0167813 A1 * 6/2016 Myers B65B 13/22
254/250

* cited by examiner

Primary Examiner — Philip S Hyder
(74) *Attorney, Agent, or Firm* — Thomas J. Nikolai;
DeWitt LLP

(57) **CLAIM**

The ornamental design for a cable tie tool, as shown and described.

DESCRIPTION

FIG. 1 is a perspective view of a cable tie tool showing my new design;
FIG. 2 is a front elevational view thereof;
FIG. 3 is a rear elevational view thereof;
FIG. 4 is a left side elevation view thereof;
FIG. 5 is a right side elevation view thereof;
FIG. 6 is a top plan view thereof; and,
FIG. 7 is a bottom plan view thereof.

1 Claim, 5 Drawing Sheets

(56) **References Cited**
U.S. PATENT DOCUMENTS
5,921,290 A * 7/1999 Dyer B65B 13/027
140/123.6
D430,781 S * 9/2000 Hillegonds D8/44
6,206,053 B1 * 3/2001 Hillegonds B65B 13/027
140/123.6
D473,773 S * 4/2003 Hillegonds D8/68
D491,430 S * 6/2004 Magno, Jr. D8/44
6,840,289 B2 * 1/2005 Hillegonds B65B 27/10
140/123.6
7,210,506 B2 * 5/2007 Magno, Jr. B23Q 17/00
140/123.6

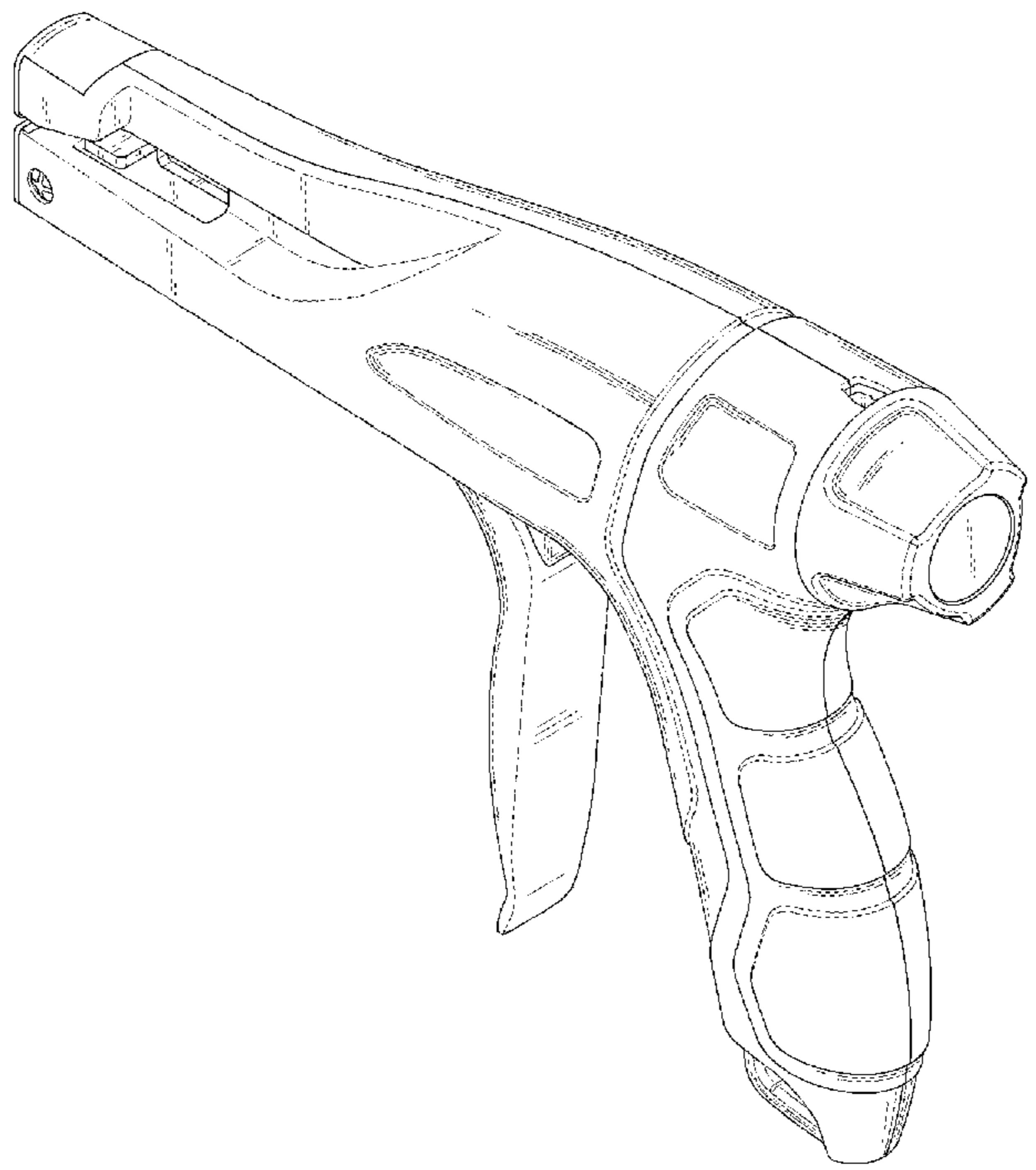



FIG. 1

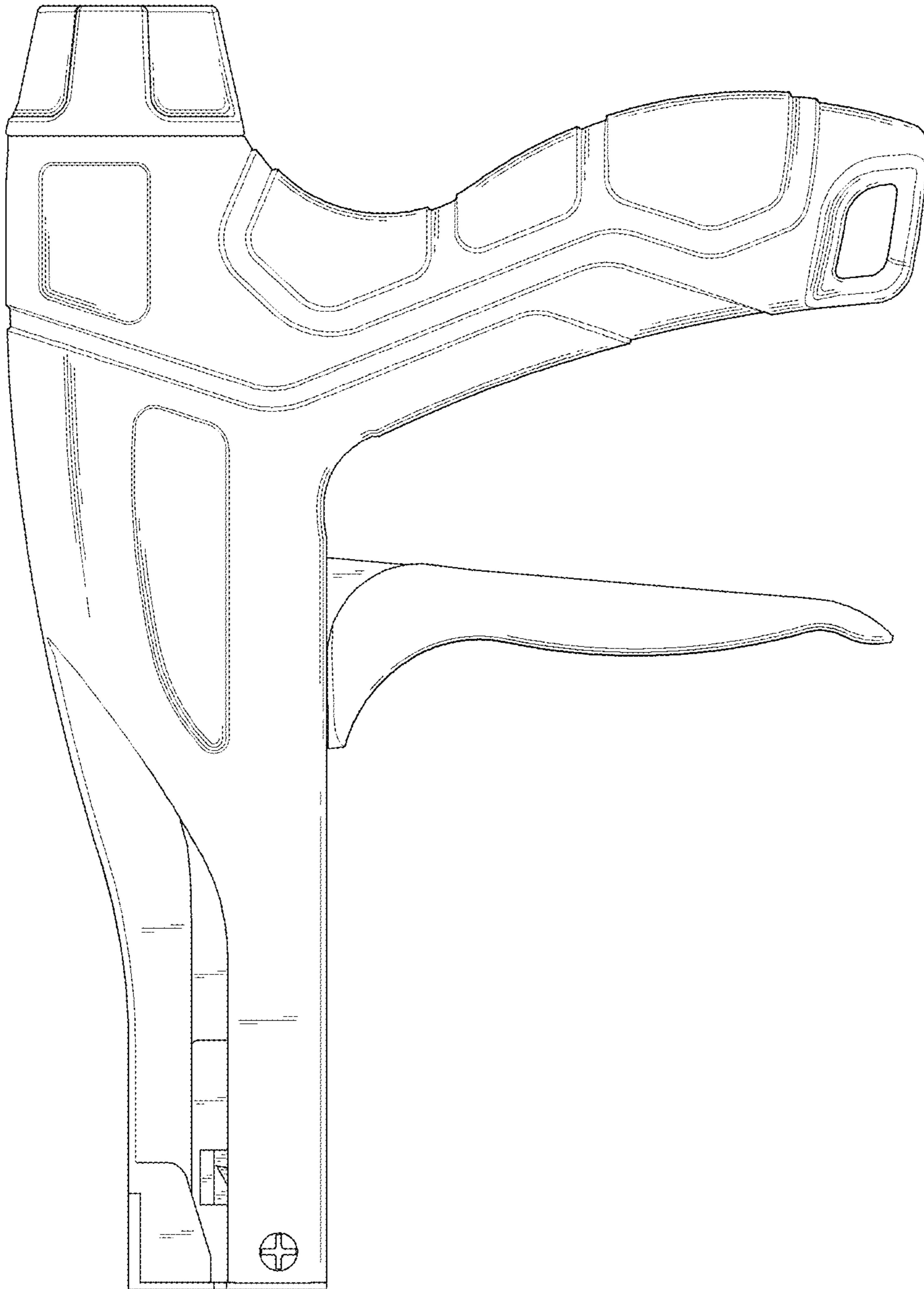

FIG. 2

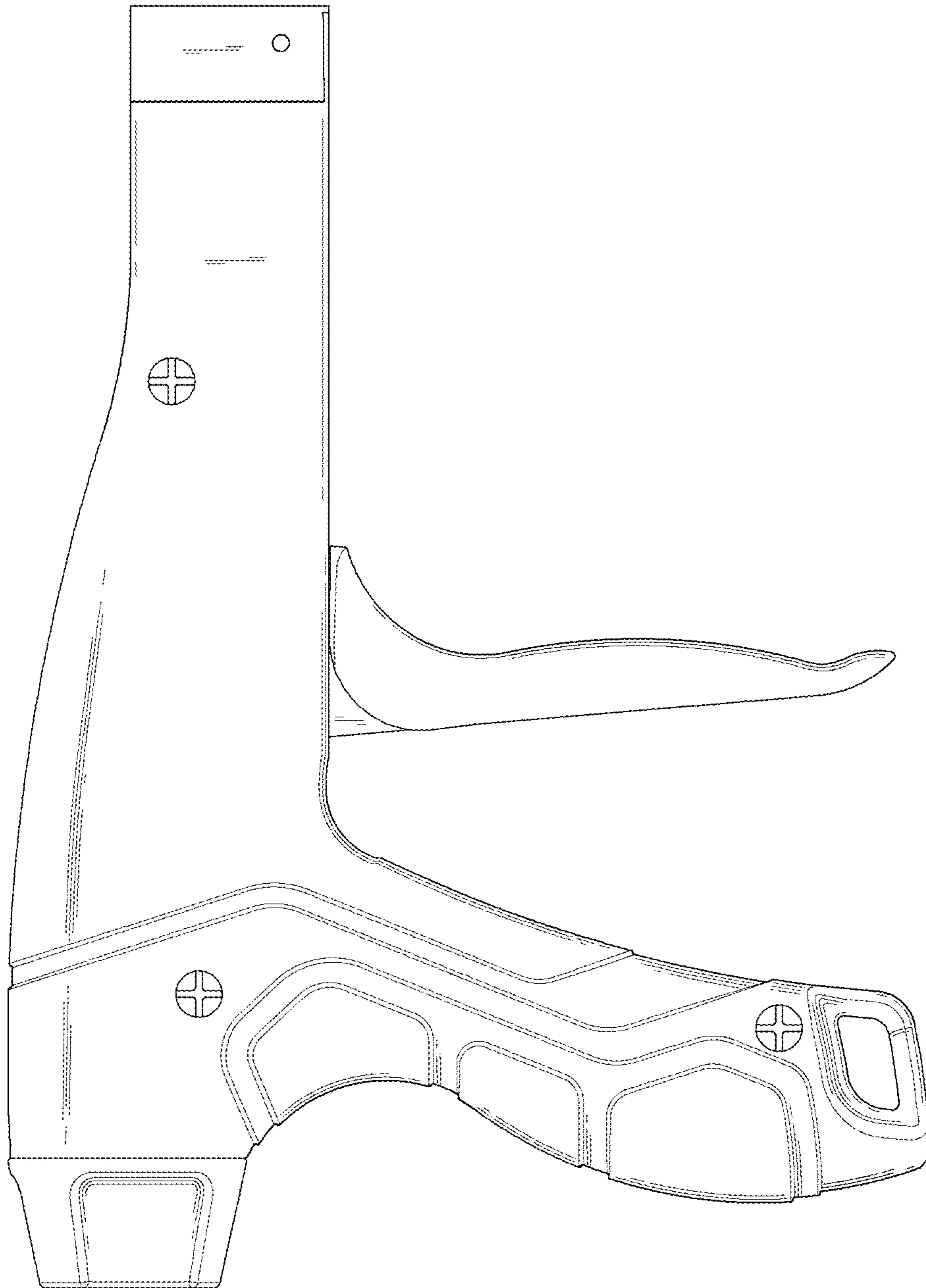

FIG. 3

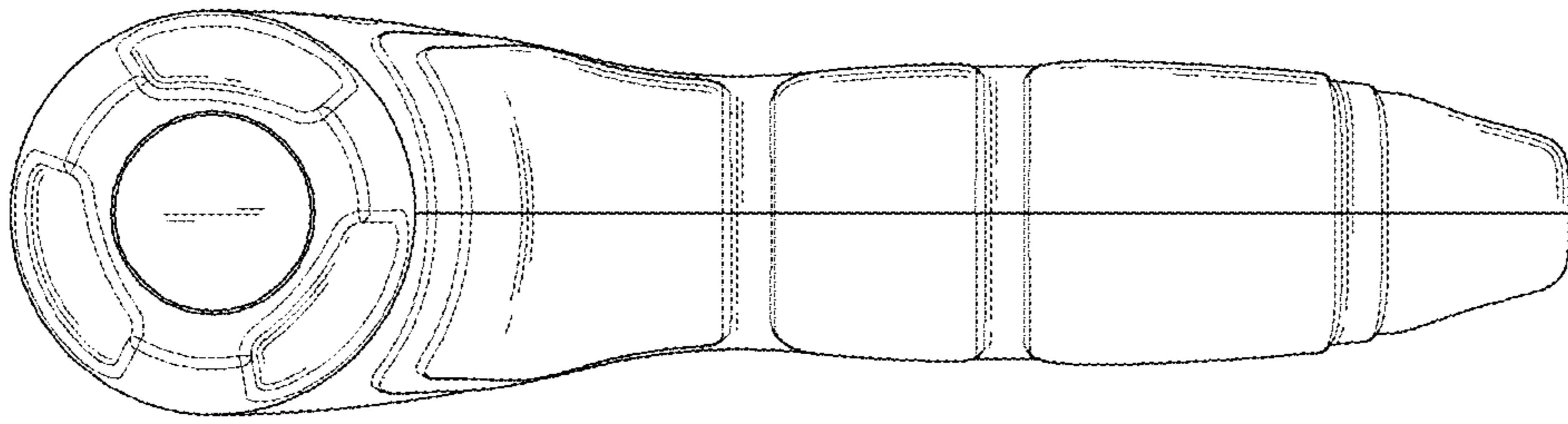

FIG. 5

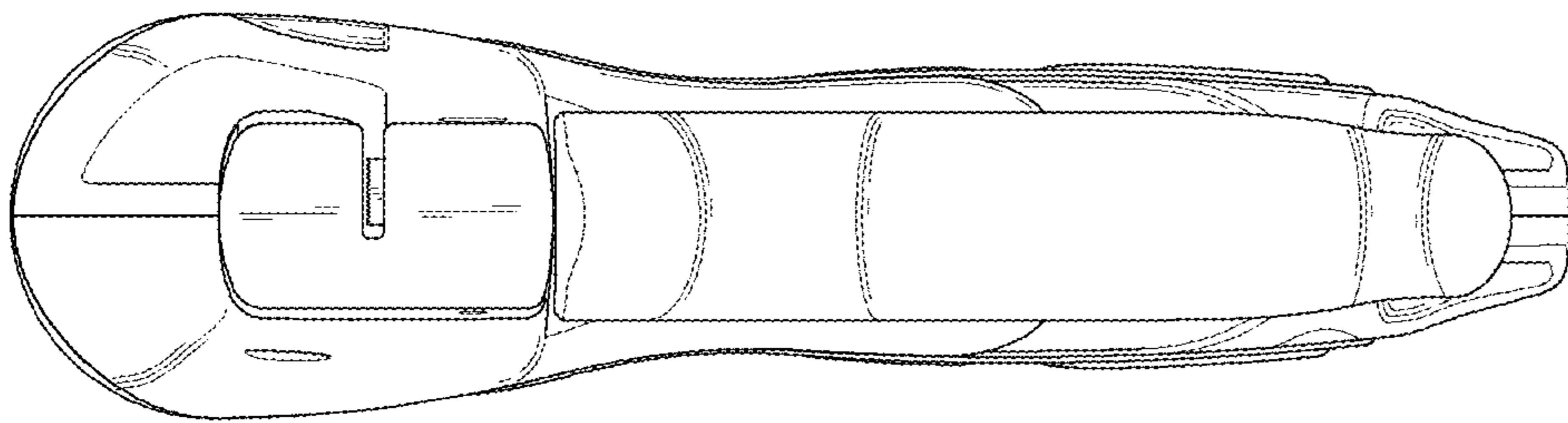

FIG. 4

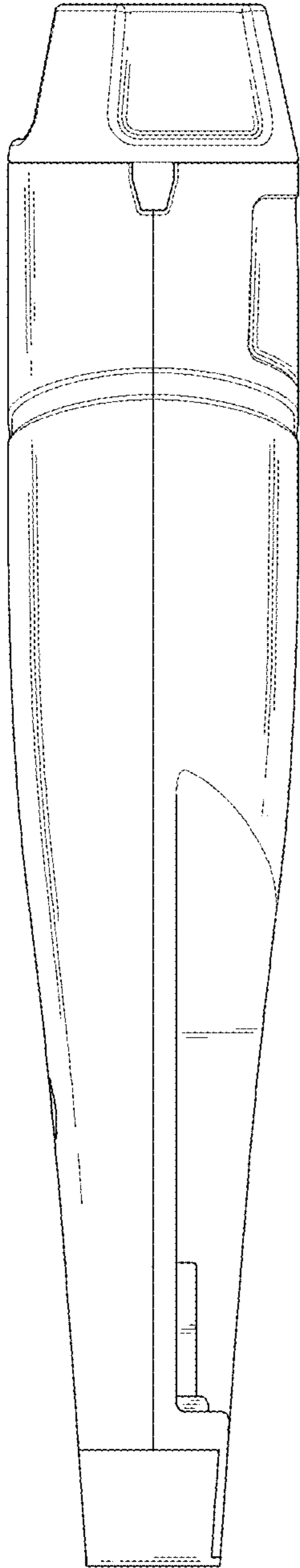

FIG. 6

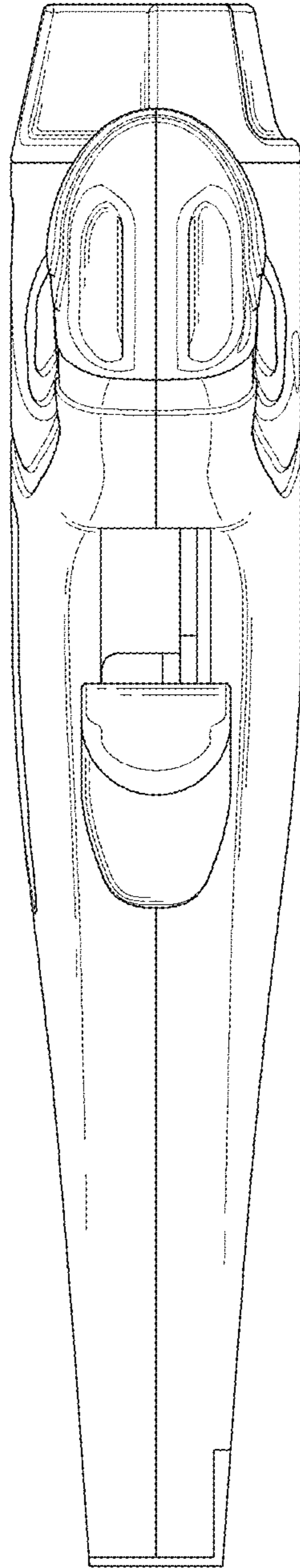

FIG. 7