



US00D885780S

(12) **United States Design Patent**  
**Oakley et al.**

(10) **Patent No.:** **US D885,780 S**  
(45) **Date of Patent:** **\*\* Jun. 2, 2020**

(54) **CHAIR**

(71) Applicant: **Regency Seating, Inc.**, Akron, OH (US)

(72) Inventors: **William Oakley**, Akron, OH (US);  
**John Summerville**, Uniontown, OH (US)

(73) Assignee: **Regency Seating, Inc.**, Akron, OH (US)

(\*\*) Term: **15 Years**

(21) Appl. No.: **29/676,747**

(22) Filed: **Jan. 14, 2019**

(51) **LOC (12) Cl.** ..... **06-01**

(52) **U.S. Cl.**  
USPC ..... **D6/379**; D6/374; D6/380

(58) **Field of Classification Search**  
USPC ..... D6/366, 367, 368, 369, 716.7, 708.16,  
D6/708.23, 372, 334, 361, 364, 375, 716,  
(Continued)

(56) **References Cited**

**U.S. PATENT DOCUMENTS**

D405,286 S \* 2/1999 James ..... D6/379  
D571,119 S \* 6/2008 Leonetti ..... D6/379  
(Continued)

**FOREIGN PATENT DOCUMENTS**

CN 303281475 \* 4/2015  
CN 303800406 \* 4/2016  
(Continued)

**OTHER PUBLICATIONS**

Zhao Ying,Zhao Ying Solid Wood Dining Chair Cloth Retro Simple and Modern Restaurant Restaurant Household Backrest Armrest

Dining Chair, Date first available Jan. 10, 2019, [online]retrieved Apr. 2, 2020, available from internet, www.amazon.com (Year: 2019).\*

(Continued)

*Primary Examiner* — Keli L Hill

*Assistant Examiner* — Sara S Sahneh

(74) *Attorney, Agent, or Firm* — Edwin A. Sisson,  
Attorney at Law, LLC; Jeffrey J. Banyas

(57) **CLAIM**

The ornamental design for a chair, as shown and described.

**DESCRIPTION**

FIG. 1 is a perspective front view of a chair;  
FIG. 2 is a front view of the chair;  
FIG. 3 is a rear view of the chair;  
FIG. 4 is a right side view of the chair;  
FIG. 5 is a left side view of the chair;  
FIG. 6 is a top view of the chair;  
FIG. 7 is a bottom view of the chair;  
FIG. 8 is a perspective front view of an alternative embodiment of a chair.  
FIG. 9 is a front view of the alternative embodiment of a chair.  
FIG. 10 is a rear view of the alternative embodiment of a chair.  
FIG. 11 is a right side view of the alternative embodiment of a chair.  
FIG. 12 is a left side view of the alternative embodiment of a chair.  
FIG. 13 is a top view of the alternative embodiment of a chair; and,  
FIG. 14 is a bottom view of the alternative embodiment of a chair.

The broken lines form no part of the claimed design.

**1 Claim, 14 Drawing Sheets**

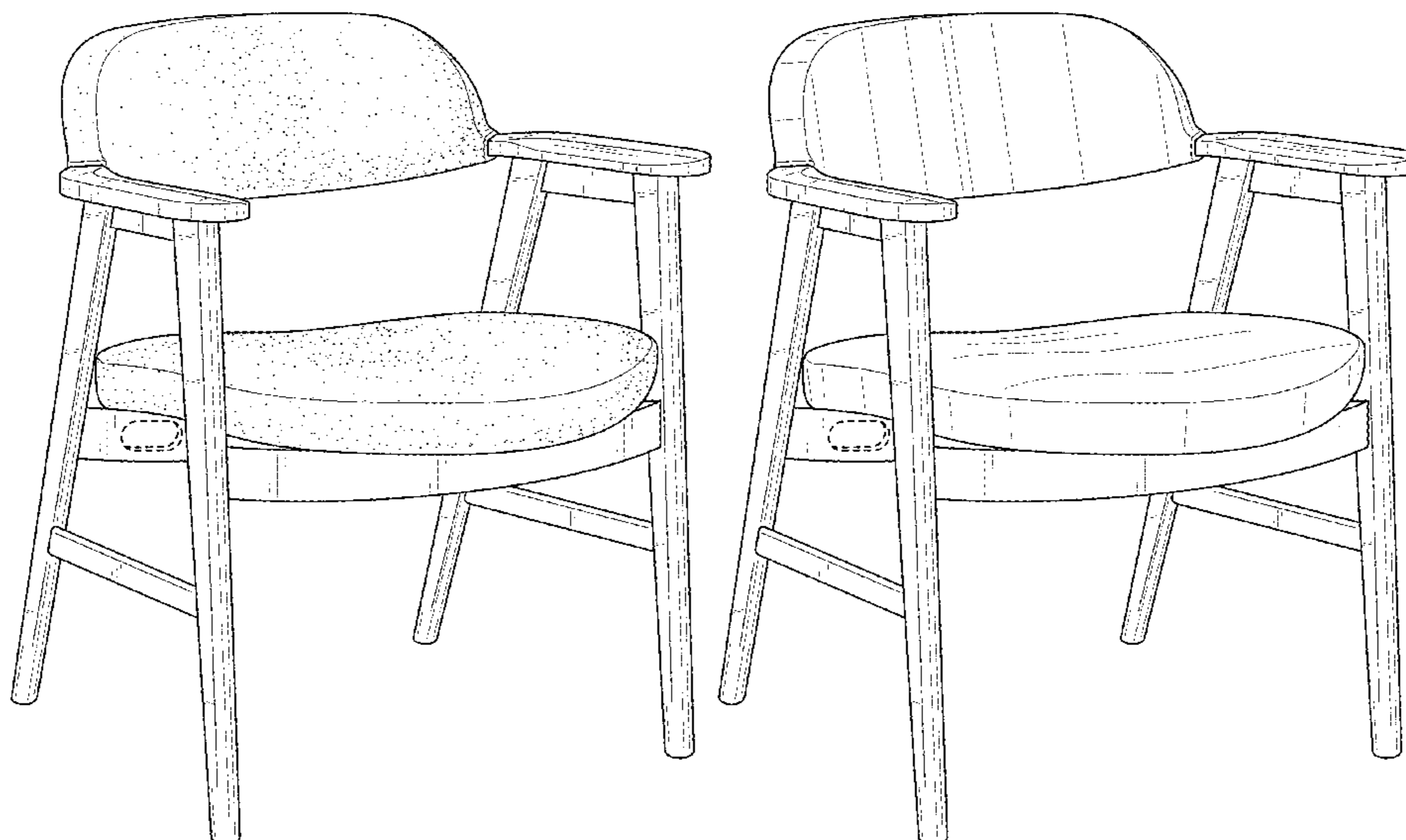

(58) **Field of Classification Search**

USPC ..... D6/360, 373, 348, 379, 358, 716.4,  
D6/707.16, 362, 339, 374, 342, 330, 329,  
D6/332, 320, 315, 380, 376  
CPC .. A47C 4/028; A47C 4/02; A47C 7/18; A47C  
7/40; A47C 7/383; A47C 7/506; A47C  
9/007; A47C 13/023; A47C 1/124; A47C  
1/04; A47C 1/16; A47C 7/16; A47C 3/04;  
A47C 3/00; B60N 2/0715; B60N 2/22;  
B60N 2/48; B60N 2/449; B60N 2/4882;  
A47D 1/00; B29L 2031/771

See application file for complete search history.

(56) **References Cited**

U.S. PATENT DOCUMENTS

D580,676 S \* 11/2008 Cramer ..... D6/379  
D654,285 S \* 2/2012 Ballendat ..... D6/379  
D686,010 S \* 7/2013 Cramer ..... D6/379  
D693,589 S \* 11/2013 Irvine ..... D6/379  
D740,046 S \* 10/2015 Levy ..... D6/379  
D763,002 S \* 8/2016 Moscheri ..... D6/379  
D807,659 S \* 1/2018 Baylar ..... D6/379

D835,427 S \* 12/2018 Inovero ..... D6/370  
D852,533 S \* 7/2019 Asner ..... D6/379  
D877,526 S \* 3/2020 Vasilev ..... D6/379

FOREIGN PATENT DOCUMENTS

CN 304770220 \* 3/2018  
CN 304977881 \* 5/2018  
CN 304923171 \* 12/2018  
CN 305078668 \* 3/2019

OTHER PUBLICATIONS

Regency, Regency Mid-Century Modern Solid Wood Upholstered Accent Chair, Cherry/Black, Date first available Aug. 1, 2019, [online]retrieved Apr. 7, 2020, available from internet, www.amazon.com (Year: 2019).\*

Abbey Avenue, Abbey Avenue Kane Fabric Chair Set Brown, Date first available Oct. 18, 2019, [online]retrieved Apr. 7, 2020, available from internet, www.amazon.com (Year: 2019).\*

2xhome, 2xhome Natural Mid Century Modern Solid Real Oak Wood PU Leather Cushion Seat Kennedy, Date first available Apr. 4, 2018, [online]retrieved Apr. 7, 2020, available from internet, www.amazon.com (Year: 2018).\*

\* cited by examiner

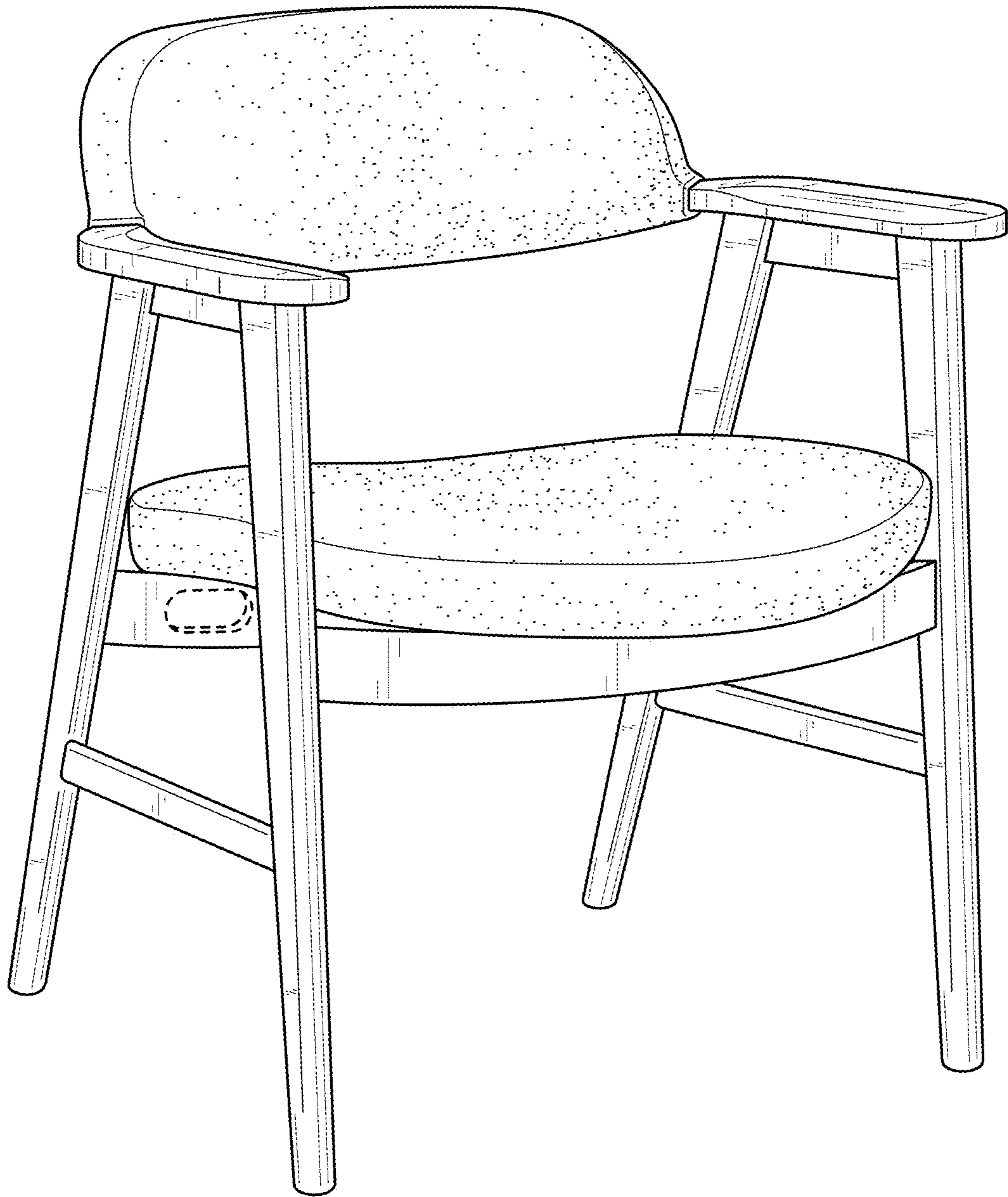

FIG. 1

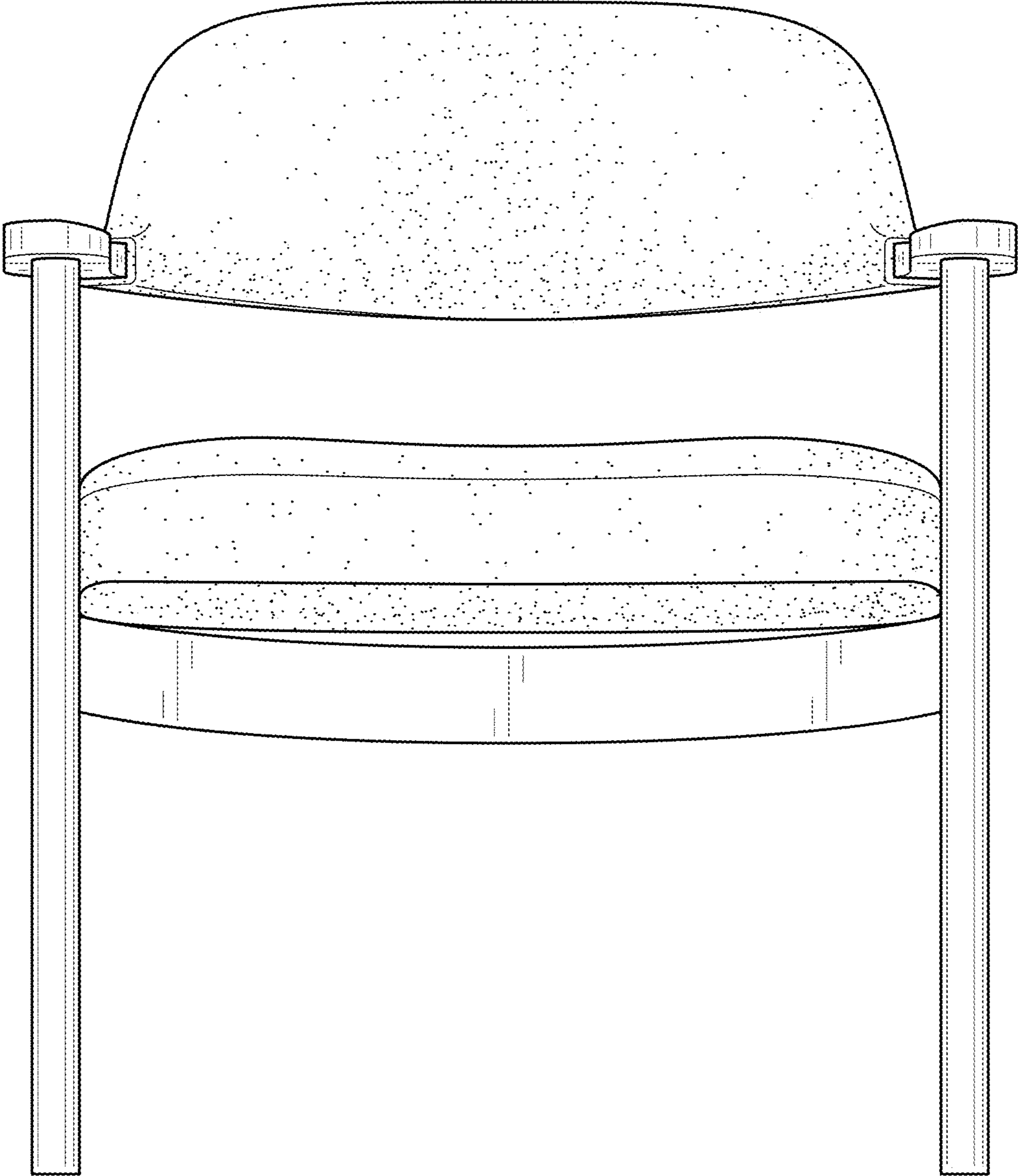

FIG. 2

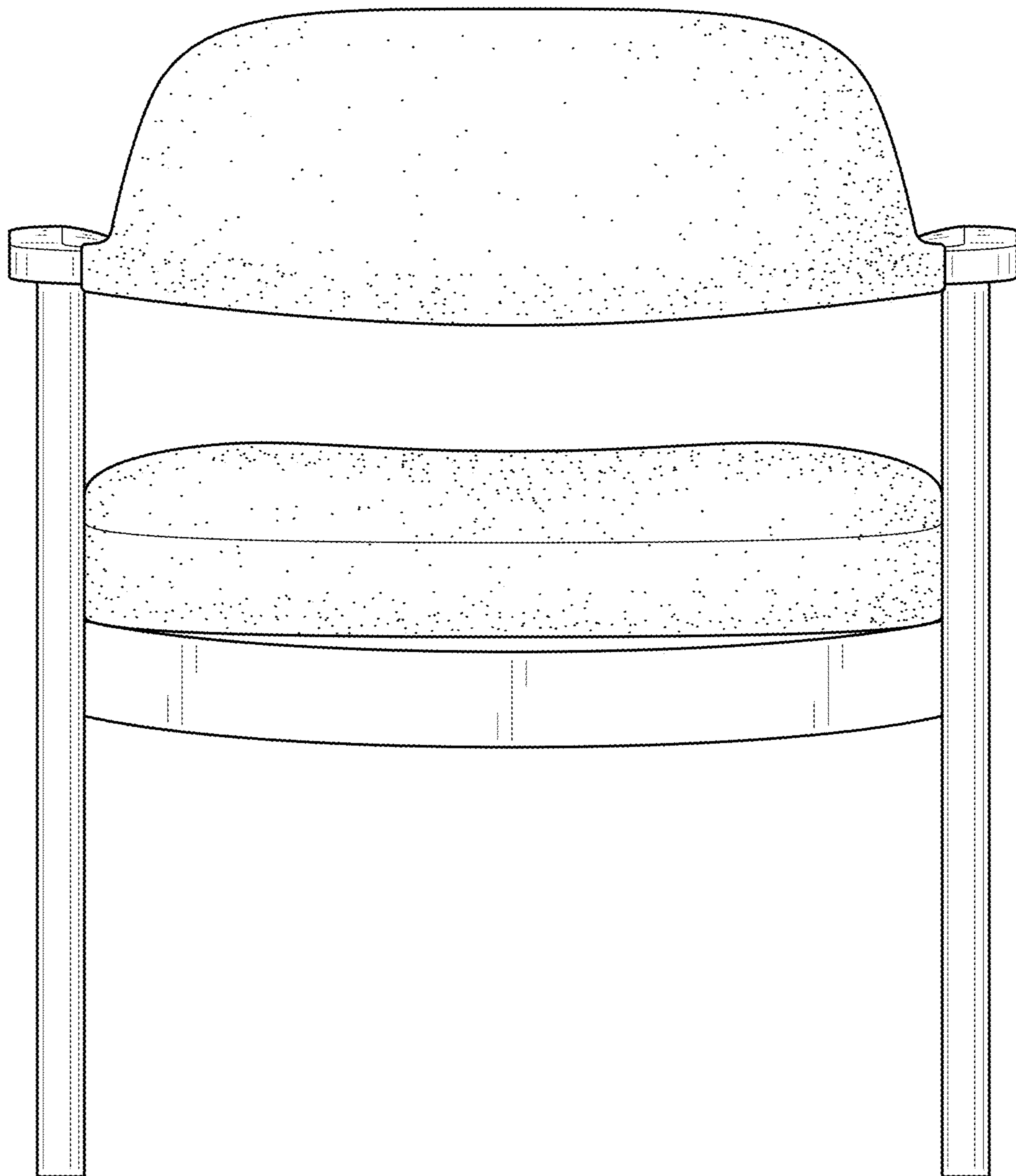

FIG. 3

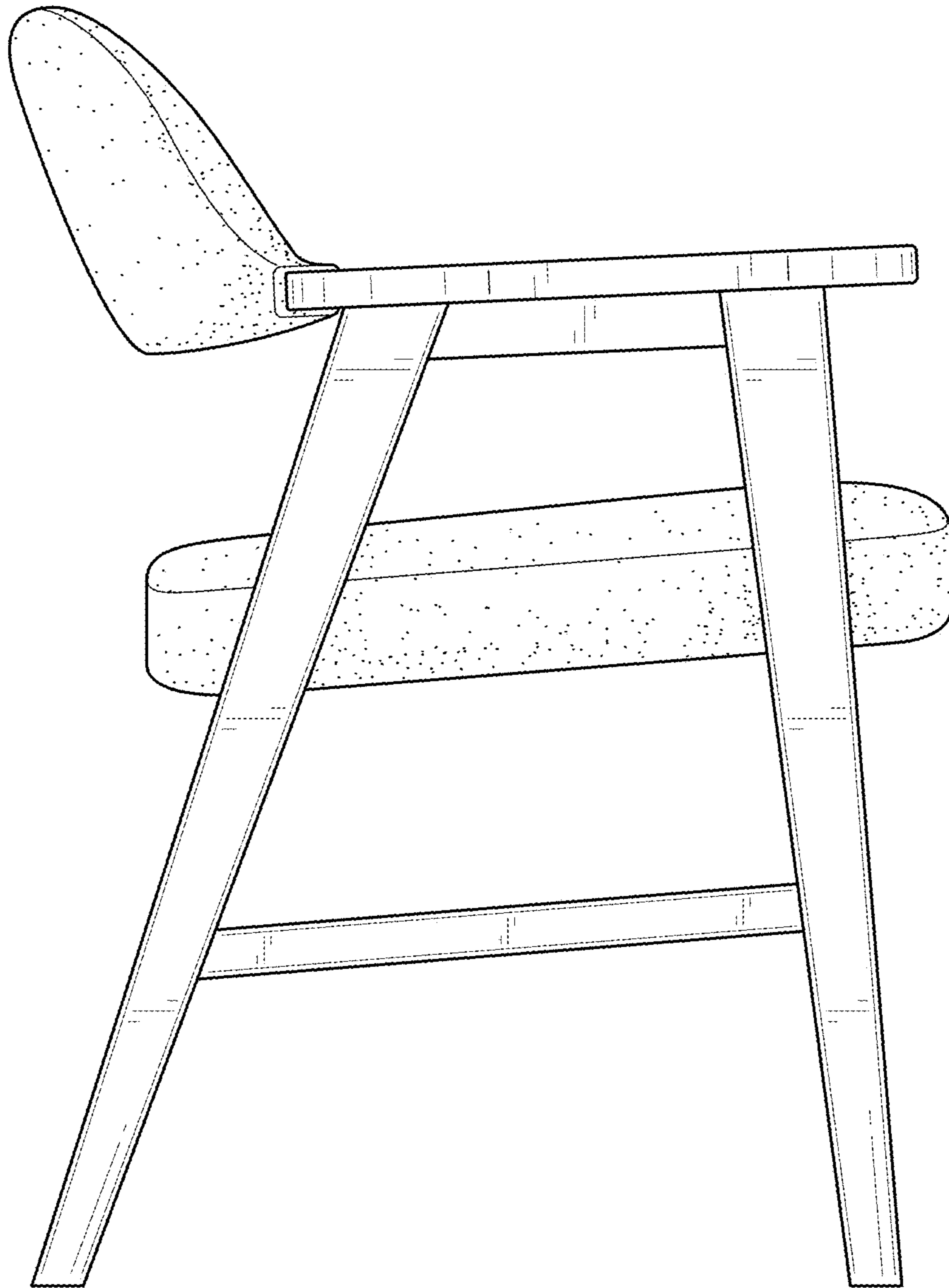

FIG. 4

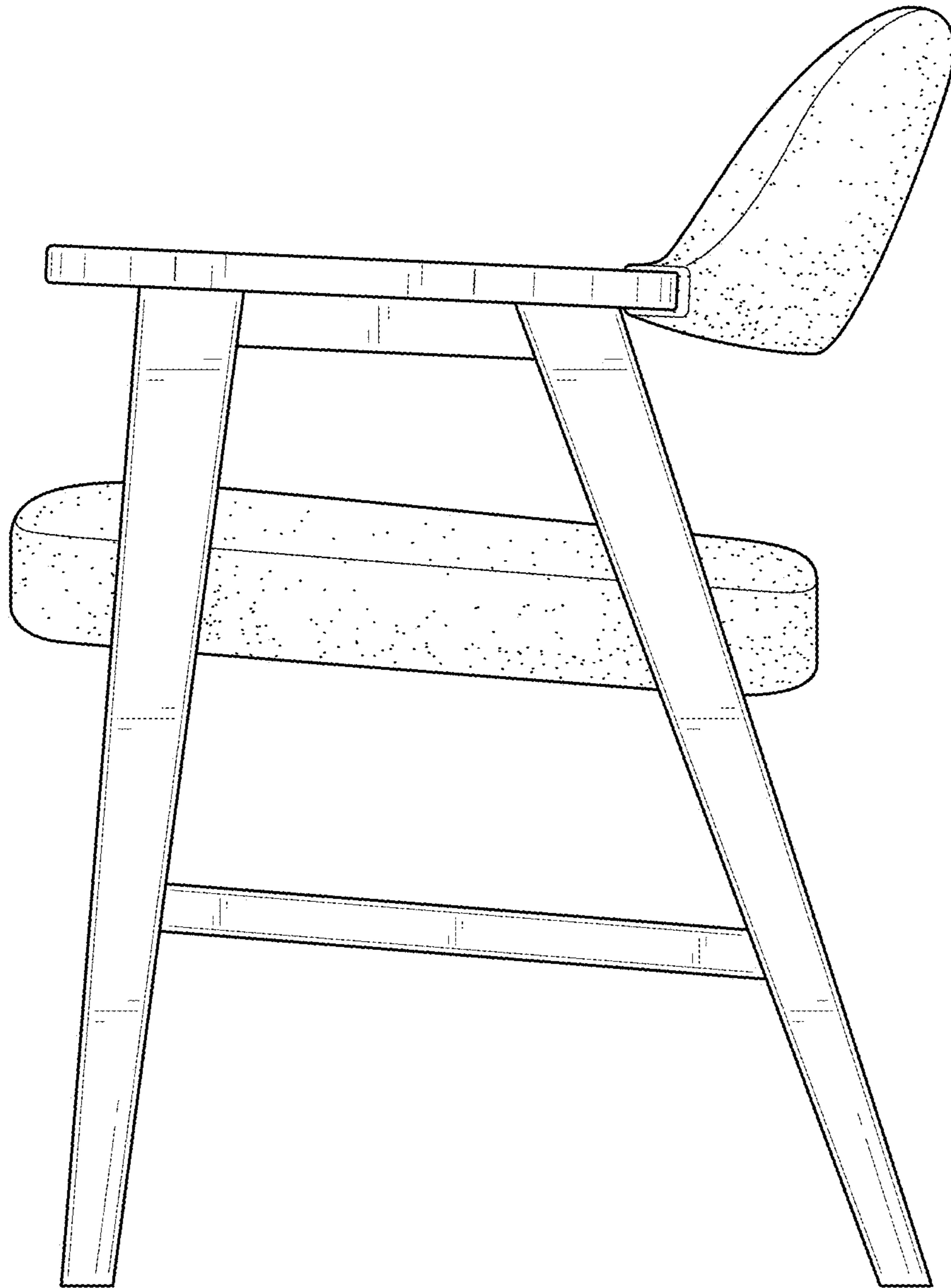

FIG. 5

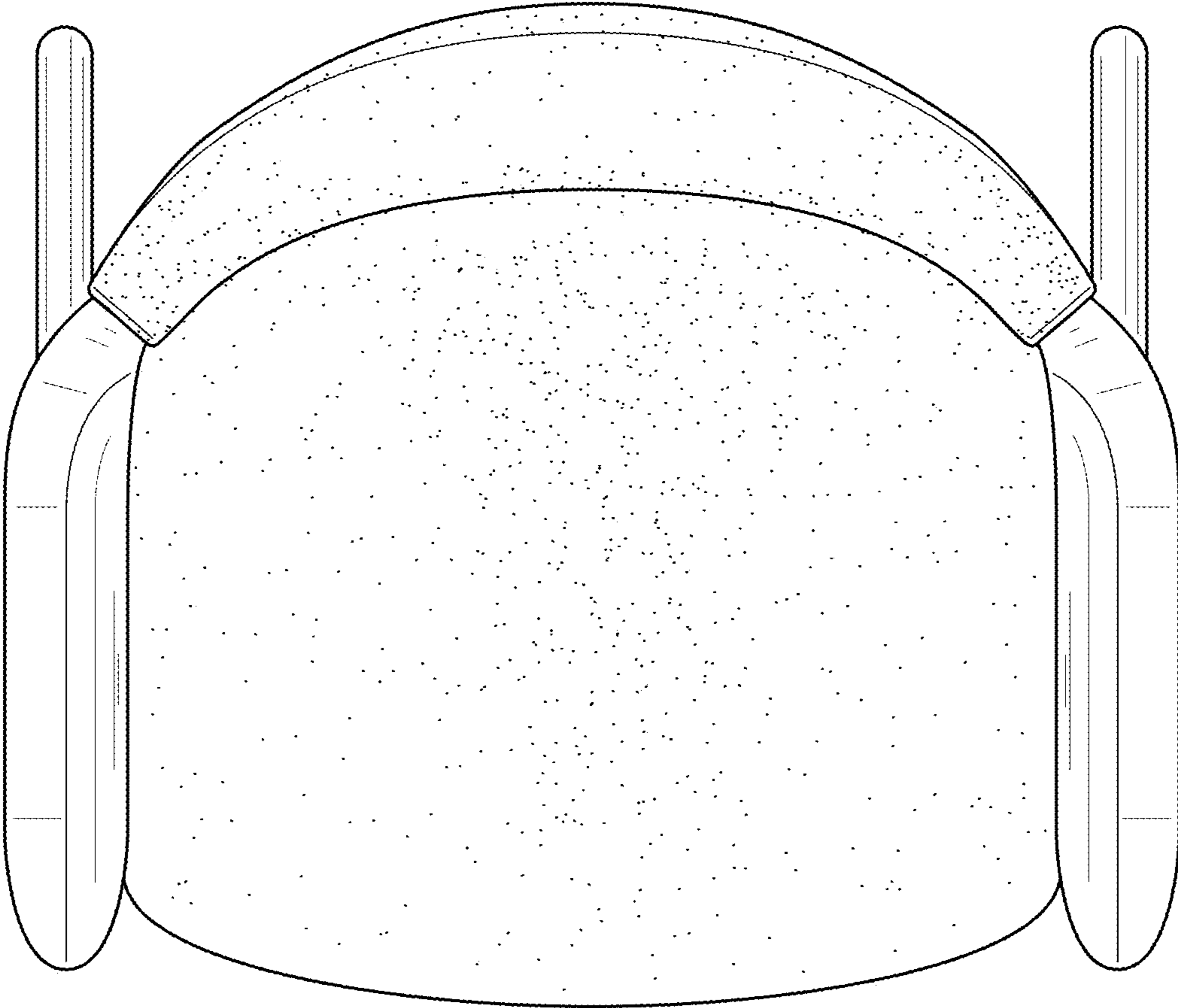

FIG. 6



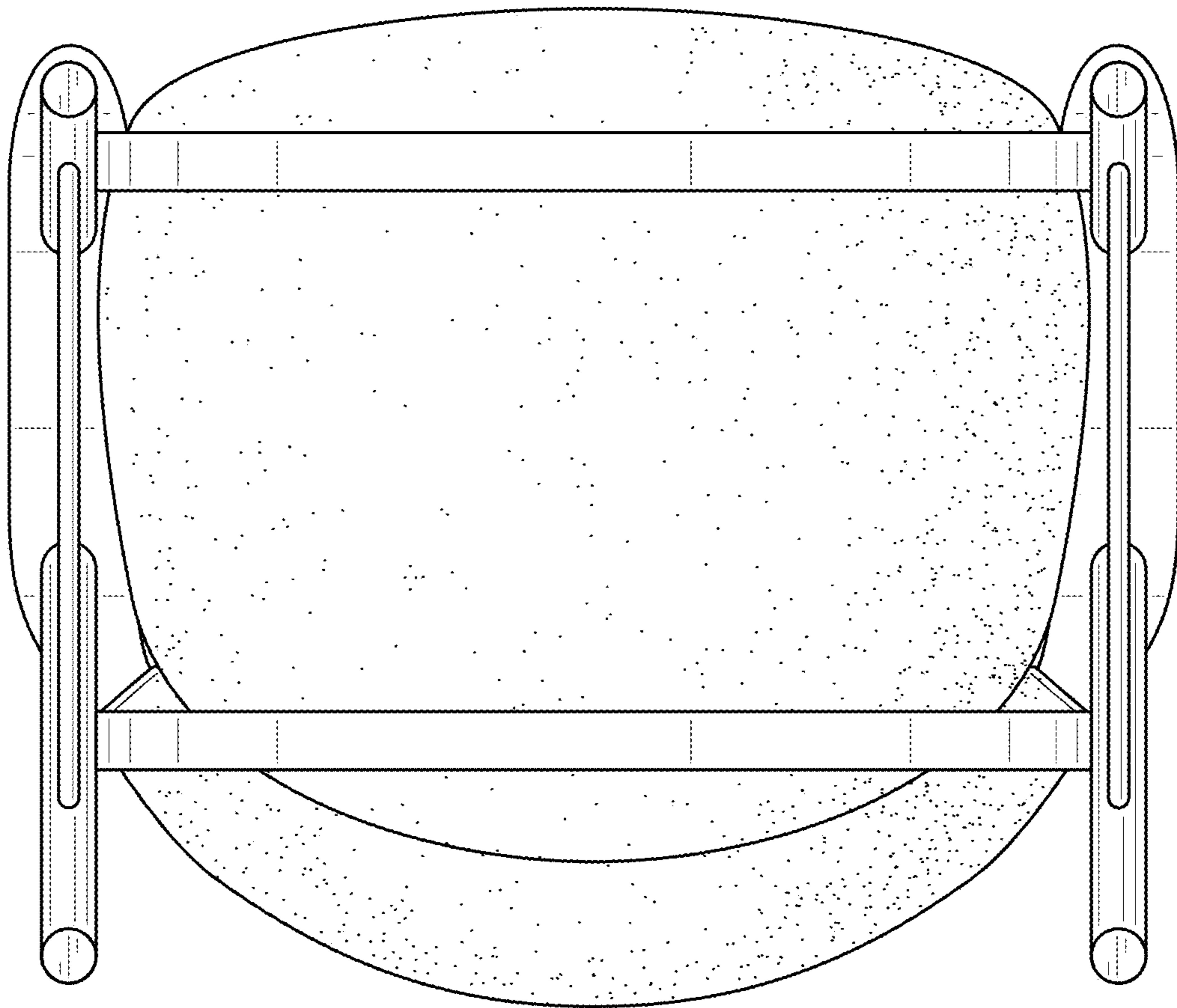

FIG. 7

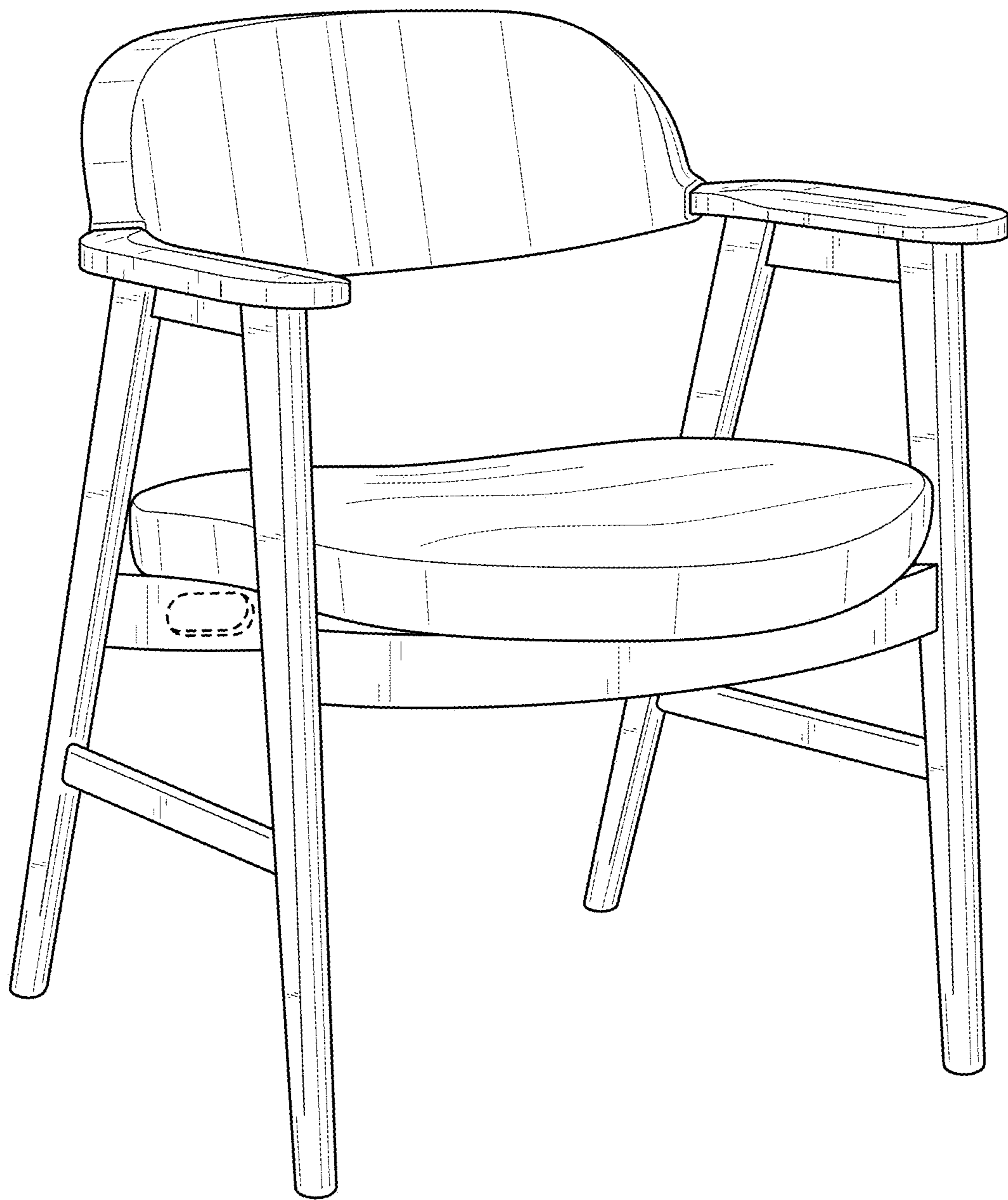

FIG. 8

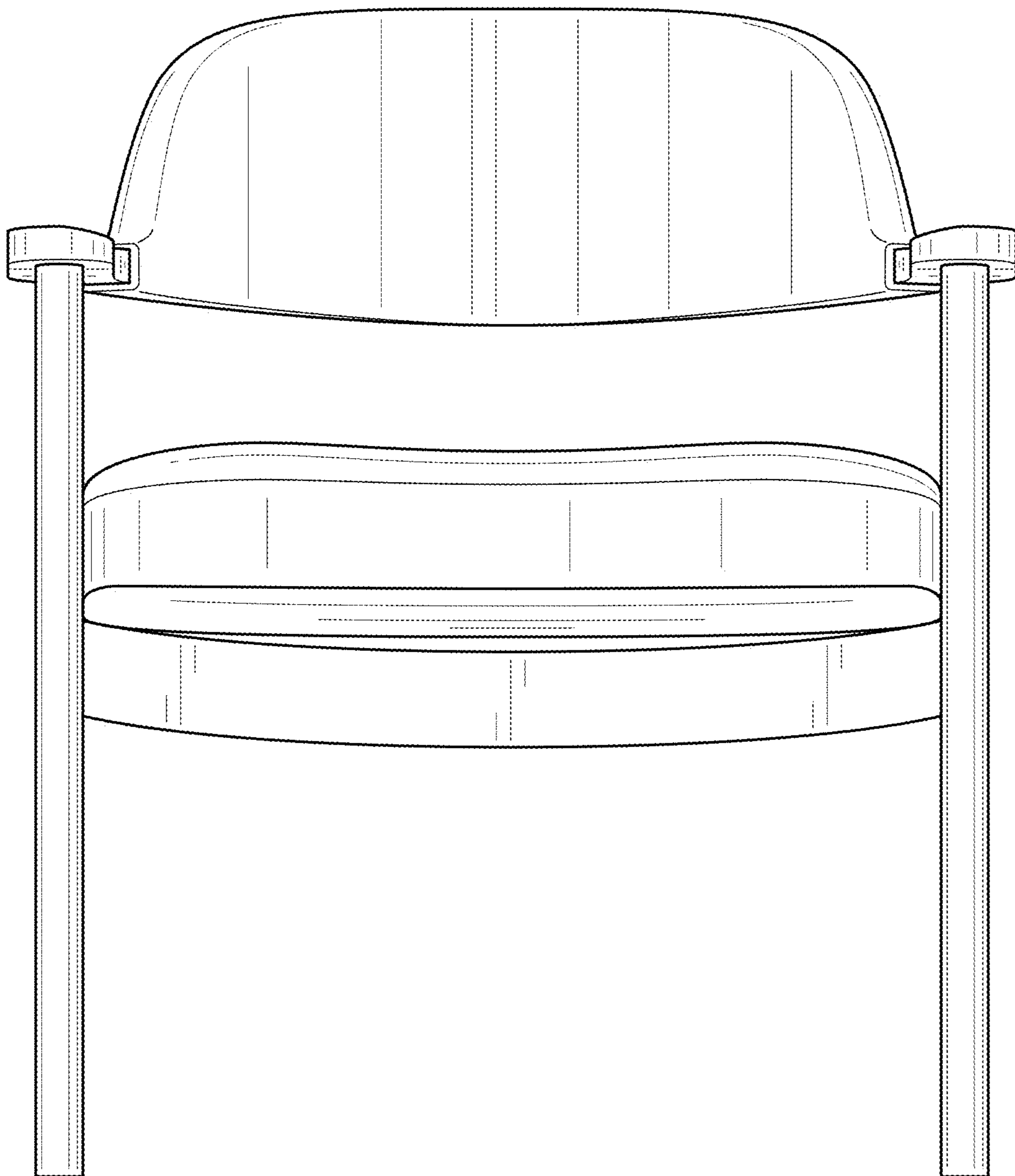

FIG. 9

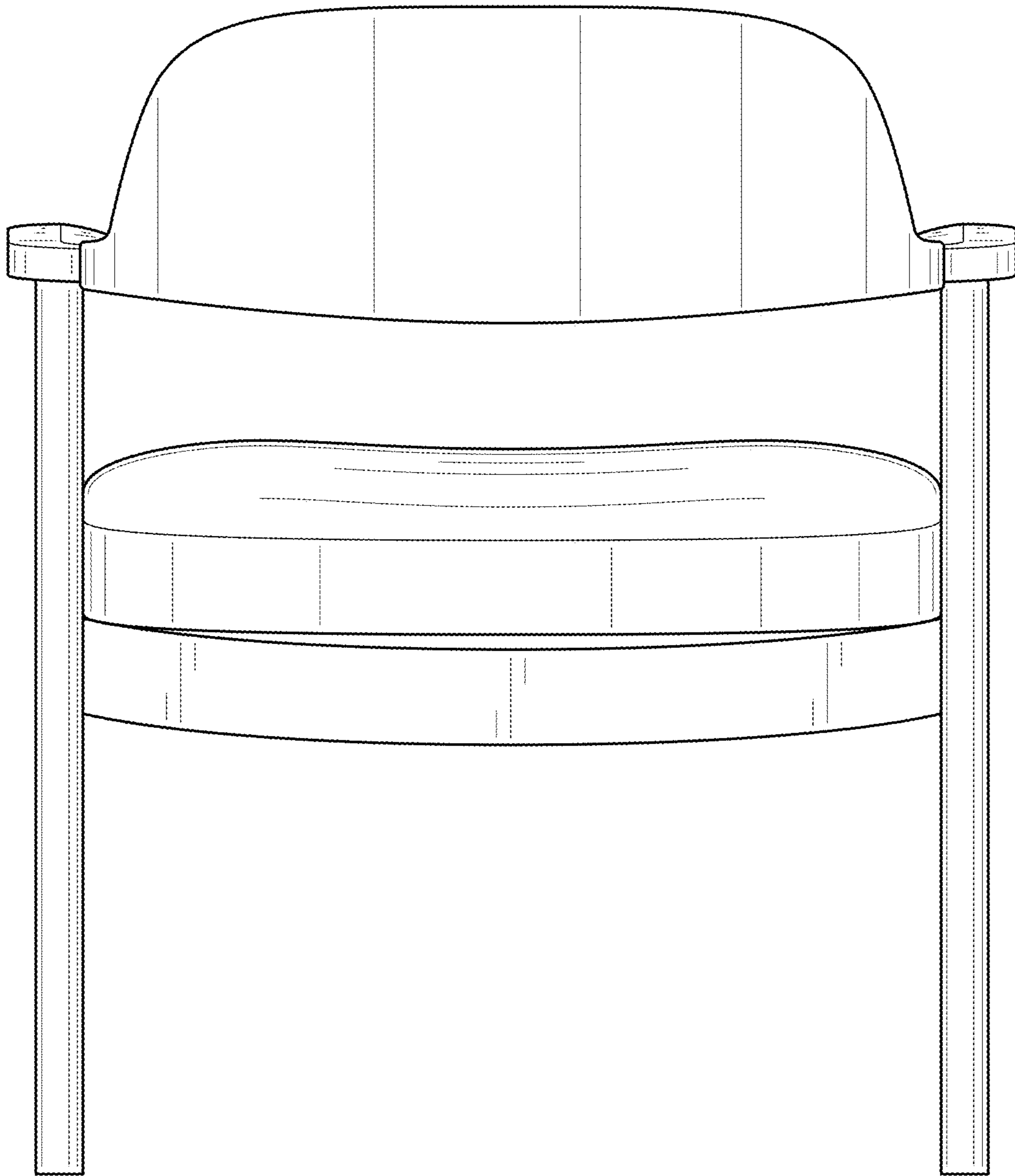

FIG. 10

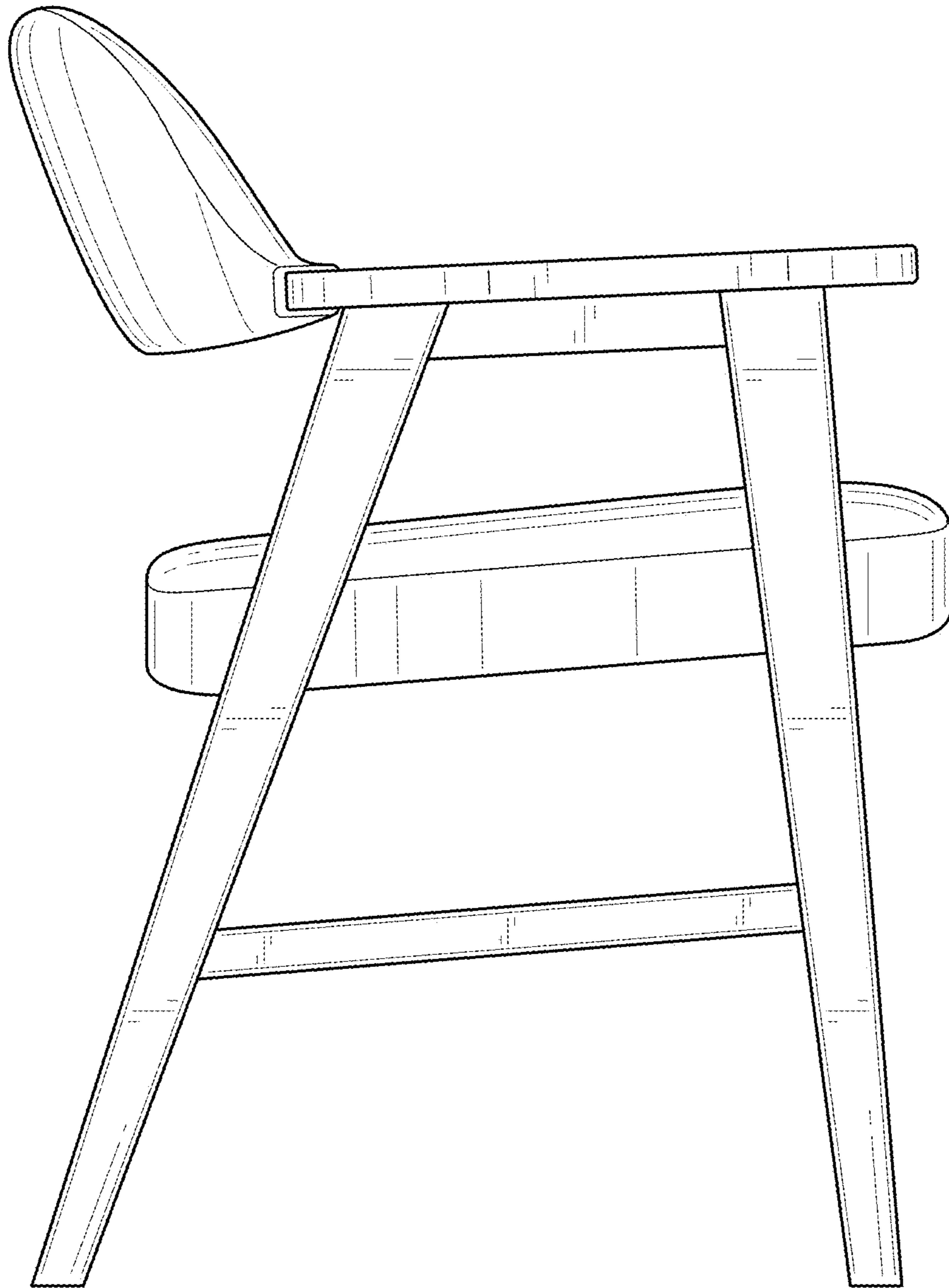

FIG. 11

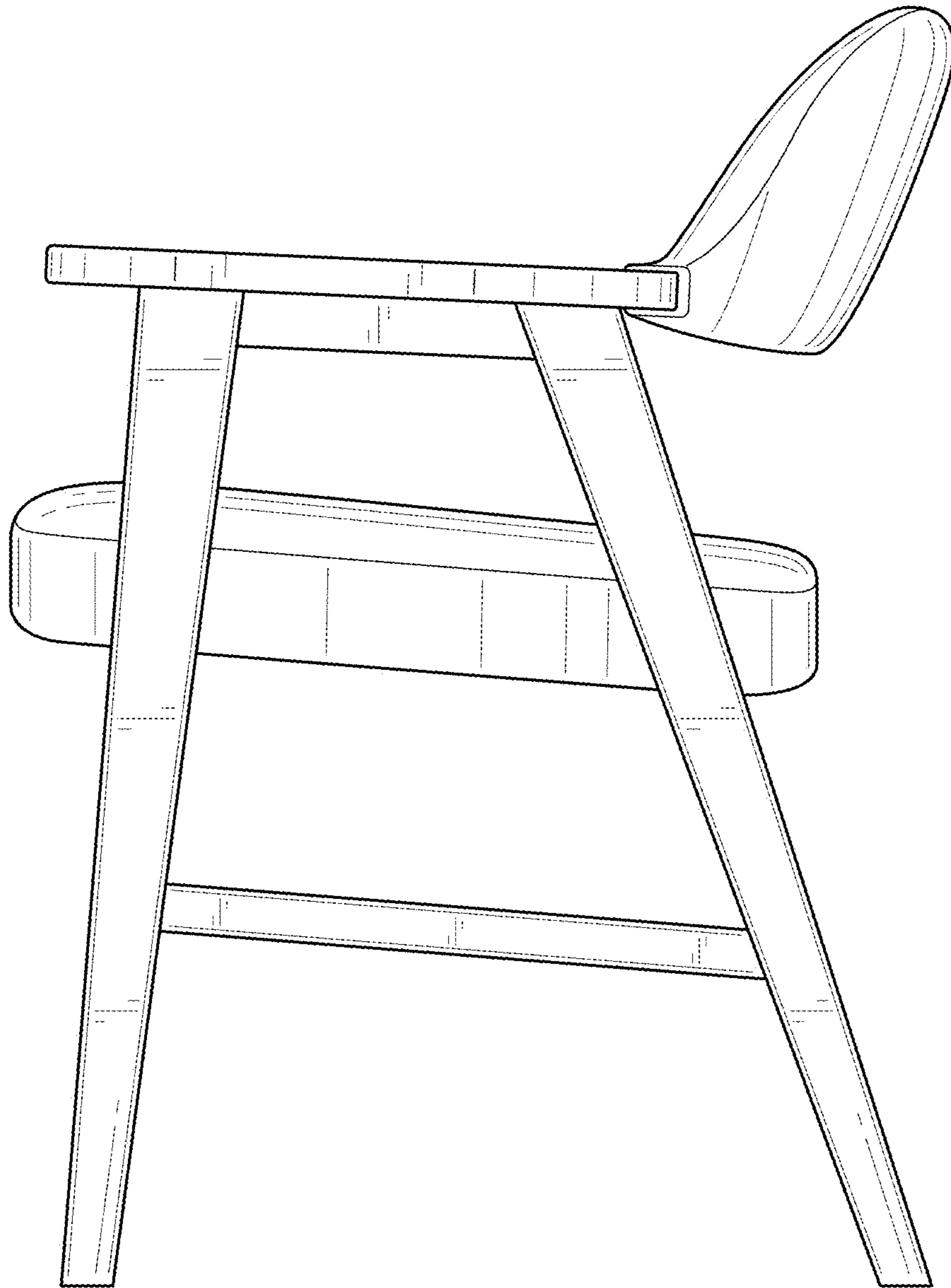

FIG. 12

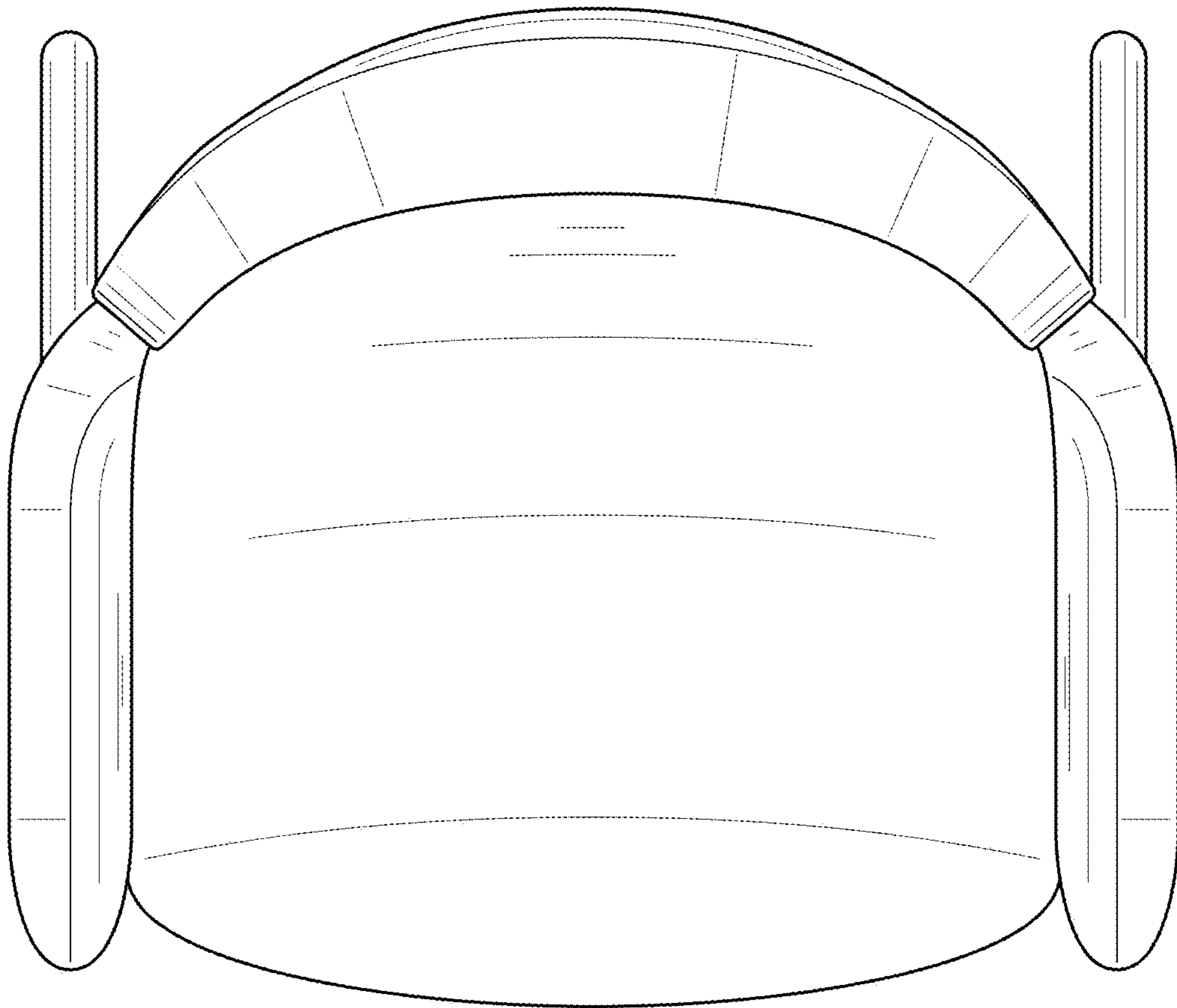

FIG. 13

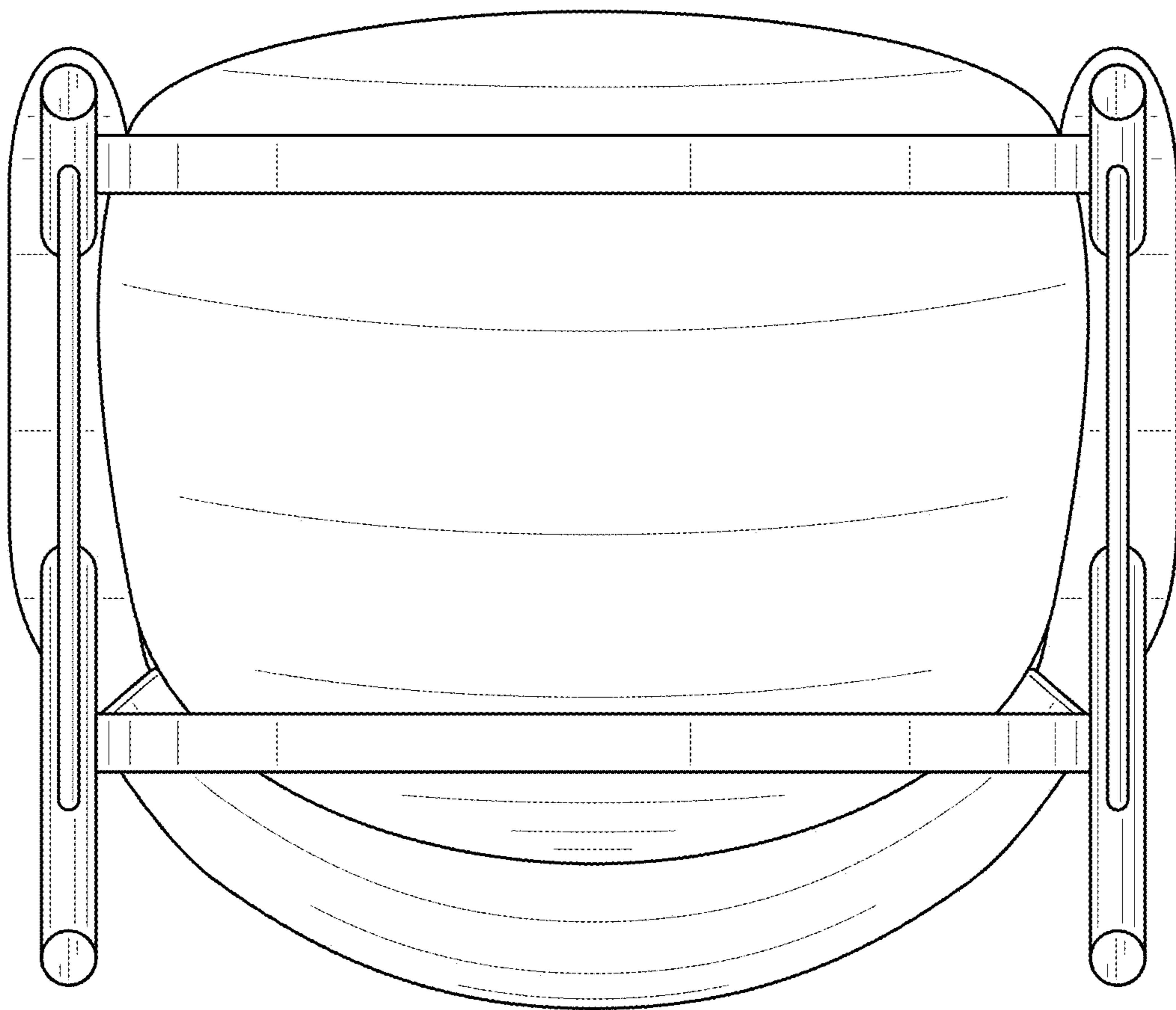

FIG. 14