



US00D885615S

(12) **United States Design Patent** (10) **Patent No.:** **US D885,615 S**
Antony et al. (45) **Date of Patent:** **** May 26, 2020**

(54) **LIGHTING MODULE LED LIGHT BOARD**

- (71) Applicant: **FLEX LTD**, Singapore (SG)
- (72) Inventors: **Ashish Antony**, Anna, TX (US); **Kevin Emr**, Dallas, TX (US); **Jordon Musser**, Dallas, TX (US)
- (73) Assignee: **FLEX LTD.**, Singapore (SG)
- (**) Term: **15 Years**
- (21) Appl. No.: **29/698,353**
- (22) Filed: **Jul. 16, 2019**

Related U.S. Application Data

- (62) Division of application No. 29/613,363, filed on Aug. 9, 2017, now Pat. No. Des. 872,319.
- (51) **LOC (12) Cl.** **26-01**
- (52) **U.S. Cl.**
USPC **D26/1**
- (58) **Field of Classification Search**
USPC D13/180; D26/1, 24, 118
CPC H01J 5/48; H01J 5/50; F21V 19/0045; F21V 19/004; F21V 19/001; F21V 9/13; F21K 19/54
See application file for complete search history.

References Cited

U.S. PATENT DOCUMENTS

D120,548 S	5/1940	Guth
D122,145 S	8/1940	Maccarthy
D122,887 S	10/1940	Beals
D123,067 S	10/1940	Rubinstein
D123,887 S	12/1940	Koehler
D127,398 S	5/1941	Jordan

(Continued)

OTHER PUBLICATIONS

Flex Essentials Series Sell Specification Sheets, Published Jun. 2016 (28 pages).

(Continued)

Primary Examiner — Brian N. Vinson
(74) *Attorney, Agent, or Firm* — Weber Rosselli & Cannon LLP

(57) **CLAIM**

What is claimed the ornamental design for a lighting module LED light board, as shown and described.

DESCRIPTION

FIG. 1 is a top, perspective view of a lighting module LED light board showing my new design;
 FIG. 2 is a front view of the lighting module LED light board of FIG. 1, shown increased in scale for clarity;
 FIG. 3 is a rear view of the lighting module LED light board of FIG. 1, shown increased in scale for clarity;
 FIG. 4 is a left, side view of the lighting module LED light board of FIG. 1;
 FIG. 5 is a right, side view of the lighting module LED light board of FIG. 1;
 FIG. 6 is a top view of the lighting module LED light board of FIG. 1;
 FIG. 7 is a bottom view of the lighting module LED light board of FIG. 1; and,
 FIG. 8 is a perspective view, with parts separated, of a lighting assembly including the lighting module LED light board of FIG. 1, with components of the lighting assembly shown in broken lines for illustrating environment of the lighting module LED light board of FIG. 1;
 The broken lines provided in the drawings form no part of the claimed design.
 Applicant reserves the right to amend the claimed invention by showing in solid lines any and all features or portions thereof originally shown in broken lines and/or by showing in broken lines any and all features or portions thereof originally shown in solid lines.

1 Claim, 4 Drawing Sheets

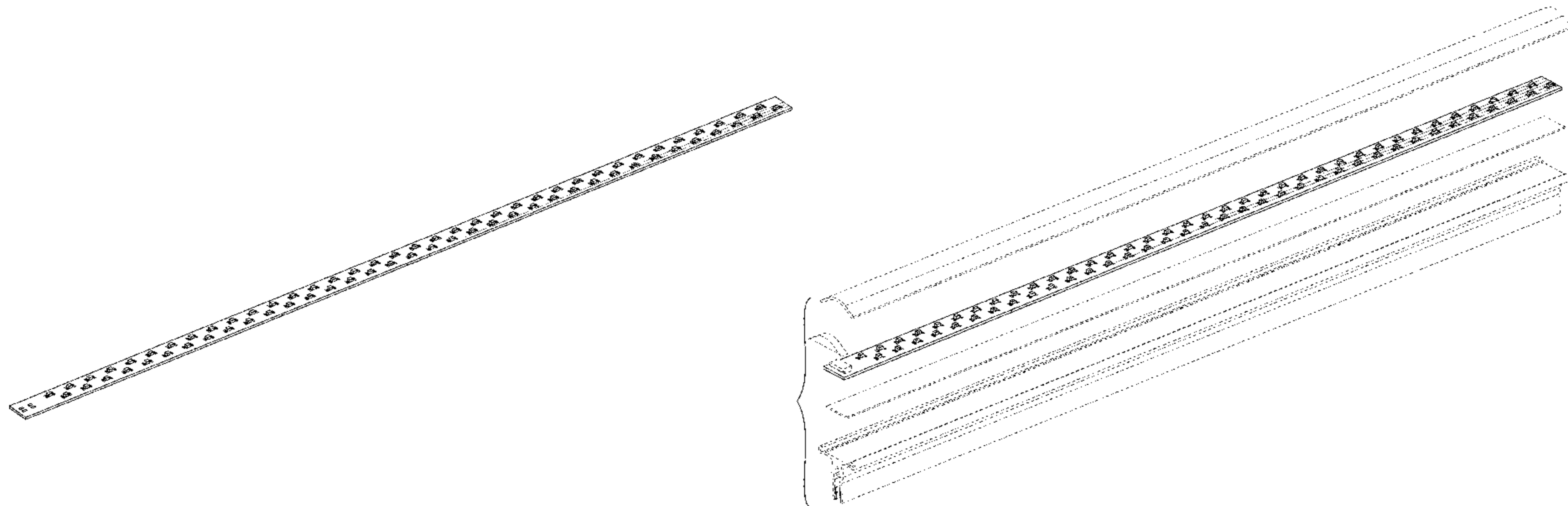

(56)

References Cited

U.S. PATENT DOCUMENTS

D128,961 S	8/1941	Hrabak	7,633,006 B1	12/2009	Swanson
D129,726 S	9/1941	Scribner	7,648,257 B2	1/2010	Villard
D130,570 S	12/1941	Borkland	7,663,342 B2	2/2010	Kimball et al.
2,312,617 A	3/1943	Beck	7,670,638 B2	3/2010	Luan et al.
D139,669 S	12/1944	Lippincott	7,681,090 B2	3/2010	Kimball et al.
D142,126 S	8/1945	Sabatini	D614,780 S *	4/2010	Huang D26/1
D150,735 S	8/1948	Marks	7,705,237 B2	4/2010	Swanson
D151,575 S	10/1948	Wyman	7,708,578 B1	5/2010	Lenox
2,606,998 A	8/1952	Winkler et al.	7,718,888 B2	5/2010	Cousins
D173,255 S	10/1954	Brooks	7,737,357 B2	6/2010	Cousins
2,715,449 A	8/1955	Lemmerman et al.	7,755,916 B2	7/2010	Krein et al.
D188,436 S	7/1960	Renaud	7,774,998 B2	8/2010	Aschenbrenner
3,009,055 A	11/1961	Michael	7,780,472 B2	8/2010	Lenox
3,209,142 A	9/1965	Michel et al.	7,786,375 B2	8/2010	Swanson et al.
D208,491 S	9/1967	Brooks	7,804,022 B2	9/2010	Ceuster
D255,851 S	7/1980	Crane	7,807,918 B2	10/2010	Shingleton et al.
D291,598 S	8/1987	Elkerbout	7,812,250 B2	10/2010	Smith
4,726,781 A	2/1988	Bernhart et al.	7,820,475 B2	10/2010	Ceuster et al.
6,061,978 A	5/2000	Dinwoodie et al.	7,824,070 B2	11/2010	Higley et al.
6,076,943 A	6/2000	Lassovsky	7,838,062 B2	11/2010	Cousins et al.
6,295,818 B1	10/2001	Ansley et al.	7,851,698 B2	12/2010	Ceuster et al.
6,313,395 B1	11/2001	Crane et al.	D632,418 S	2/2011	Bisberg et al.
6,333,457 B1	12/2001	Mulligan et al.	7,883,343 B1	2/2011	Mulligan et al.
6,337,283 B1	1/2002	Verlinden et al.	7,888,587 B2	2/2011	Shingleton et al.
6,387,726 B1	5/2002	Verlinden et al.	7,888,588 B2	2/2011	Shingleton
6,423,568 B1	7/2002	Verlinden et al.	7,893,409 B1	2/2011	Cousins
6,495,750 B1	12/2002	Dinwoodie	7,897,867 B1	3/2011	Mulligan et al.
6,501,013 B1	12/2002	Dinwoodie	7,945,413 B2	5/2011	Krein
D472,007 S	3/2003	Weitgasser	7,956,281 B2	6/2011	O'Brien et al.
6,536,326 B2	3/2003	Unger et al.	7,958,886 B2	6/2011	Barsun et al.
6,570,084 B2	5/2003	Dinwoodie	7,982,434 B2	7/2011	Kimball et al.
6,684,637 B2	2/2004	Beale	D642,994 S *	8/2011	Lin D13/180
6,722,357 B2	4/2004	Shingleton	7,994,657 B2	8/2011	Kimball et al.
6,745,687 B1	6/2004	Kaminar	8,004,865 B2	8/2011	Krein et al.
D492,809 S	7/2004	Weitgasser	8,008,575 B2	8/2011	Ceuster et al.
6,809,251 B2	10/2004	Dinwoodie	D644,609 S	9/2011	Marroquin
6,809,253 B2	10/2004	Dinwoodie	D644,610 S	9/2011	Marroquin
6,883,290 B2	4/2005	Dinwoodie	8,029,683 B2	10/2011	Rose et al.
D510,315 S	10/2005	Shugar et al.	8,061,091 B2	11/2011	Botkin et al.
D511,576 S	11/2005	Shingleton et al.	8,062,693 B2	11/2011	Cousins
D516,017 S	2/2006	Mascolo	8,065,844 B2	11/2011	Botkin et al.
6,998,288 B1	2/2006	Smith et al.	8,080,819 B2	12/2011	Mueller et al.
D519,444 S	4/2006	Mascolo	8,101,849 B2	1/2012	Almy et al.
D521,172 S	5/2006	Chen	8,108,081 B2	1/2012	Lenox
7,072,096 B2	7/2006	Holman et al.	8,120,933 B2	2/2012	Chapman et al.
7,135,350 B1	11/2006	Smith et al.	8,134,217 B2	3/2012	Rim et al.
7,140,742 B2	11/2006	Pohlert et al.	8,148,627 B2	4/2012	Rose et al.
7,144,214 B2	12/2006	Kinpara et al.	8,158,877 B2	4/2012	Klein et al.
7,155,870 B2	1/2007	Almy	8,163,638 B2	4/2012	Ceuster et al.
7,172,184 B2	2/2007	Pavani et al.	8,172,989 B2	5/2012	Pass
7,178,295 B2	2/2007	Dinwoodie	8,174,856 B2	5/2012	Chapman
7,178,941 B2	2/2007	Roberge et al.	8,188,363 B2	5/2012	Xavier et al.
7,297,865 B2	11/2007	Terao et al.	8,192,048 B2	6/2012	Kristoffersen et al.
7,297,866 B2	11/2007	Aschenbrenner	8,192,056 B2	6/2012	Villard
D562,225 S	2/2008	Almy et al.	8,193,788 B2	6/2012	Chapman
7,328,534 B2	2/2008	Dinwoodie	8,198,528 B2	6/2012	Luan et al.
RE40,158 E	3/2008	Weitgasser	8,206,009 B2	6/2012	Tickner et al.
D564,958 S	3/2008	Almy et al.	8,207,444 B2	6/2012	Cousins
7,339,110 B1	3/2008	Mulligan et al.	8,207,637 B2	6/2012	Marroquin et al.
D565,505 S	4/2008	Shugar et al.	8,211,731 B2	7/2012	Harley et al.
D565,515 S *	4/2008	Chen D13/180	8,215,071 B2	7/2012	Lenox
7,388,147 B2	6/2008	Mulligan et al.	8,220,210 B2	7/2012	Botkin et al.
7,390,961 B2	6/2008	Aschenbrenner et al.	8,221,600 B2	7/2012	Ganti
7,435,134 B2	10/2008	Lenox	8,221,601 B2	7/2012	Chen et al.
7,438,432 B2	10/2008	Yaphe et al.	8,222,516 B2	7/2012	Cousins
7,455,787 B2	11/2008	Rose et al.	8,227,942 B2	7/2012	Marroquin et al.
7,468,485 B1	12/2008	Swanson	8,230,850 B2	7/2012	Barsun et al.
D586,737 S	2/2009	Shugar et al.	D665,105 S *	8/2012	Betsuda D26/1
D592,785 S	5/2009	Bisberg et al.	8,234,824 B2	8/2012	Botkin et al.
7,530,830 B1	5/2009	Lenox	8,242,354 B2	8/2012	Smith
D594,576 S *	6/2009	Chan D26/1	D666,974 S	9/2012	Marroquin et al.
7,554,030 B2	6/2009	Shingleton	8,258,395 B2	9/2012	Wares
7,554,031 B2	6/2009	Swanson et al.	8,263,899 B2	9/2012	Harley et al.
7,557,292 B2	7/2009	Shingleton et al.	8,276,329 B2	10/2012	Lenox
7,622,912 B1	11/2009	Adams et al.	8,279,642 B2	10/2012	Chapman et al.
			8,279,649 B2	10/2012	Esrasm et al.
			8,284,574 B2	10/2012	Chapman et al.
			8,291,654 B2	10/2012	Botkin et al.
			8,294,022 B2	10/2012	Lenox

(56)

References Cited

U.S. PATENT DOCUMENTS

8,304,644 B2	11/2012	Wares et al.	8,658,454 B2	2/2014	Pass et al.
8,308,324 B2	11/2012	Horn et al.	D700,991 S	3/2014	Johnson et al.
8,317,987 B2	11/2012	Abas et al.	8,661,753 B2	3/2014	Lenox
D673,320 S	12/2012	Guercio et al.	8,662,008 B2	3/2014	Abas et al.
8,322,300 B2	12/2012	Pavani et al.	8,664,519 B2	3/2014	Ceuster et al.
8,324,015 B2	12/2012	Harley et al.	8,679,889 B2	3/2014	Cousins et al.
8,325,499 B2	12/2012	Krein et al.	D703,858 S	4/2014	Miller
8,334,161 B2	12/2012	Dennis et al.	8,683,761 B2	4/2014	Danning
8,334,489 B2	12/2012	Beardsworth et al.	8,692,111 B2	4/2014	Kim et al.
8,336,539 B2	12/2012	Linderman et al.	8,709,851 B2	4/2014	Dennis et al.
8,350,411 B2	1/2013	Kimball et al.	8,712,745 B2	4/2014	Wayne et al.
8,350,417 B1	1/2013	Dooley et al.	8,716,596 B1	5/2014	Swanson
8,352,220 B2	1/2013	Wayne et al.	8,737,093 B1	5/2014	Baker et al.
8,360,601 B2	1/2013	Muschaweck et al.	8,737,100 B2	5/2014	Chapman et al.
8,377,738 B2	2/2013	Dennis et al.	8,744,791 B1	6/2014	Kraft et al.
8,378,706 B2	2/2013	Kinyon et al.	8,748,736 B2	6/2014	Luan et al.
8,393,707 B2	3/2013	Cudzinovic et al.	8,754,627 B1	6/2014	Le
8,399,287 B1	3/2013	Mulligan et al.	8,757,567 B2	6/2014	Ciasulli et al.
8,402,703 B2	3/2013	Brandt et al.	8,763,316 B2	7/2014	Concho et al.
8,409,902 B1	4/2013	Harley et al.	8,767,421 B2	7/2014	Chapman
8,409,911 B2	4/2013	Cousins	8,772,894 B2	7/2014	Smith
8,409,912 B2	4/2013	Ceuster et al.	8,774,007 B2	7/2014	Hussain et al.
8,423,312 B2	4/2013	Krein	8,776,781 B2	7/2014	Meydbray
8,424,255 B2	4/2013	Lenox et al.	8,778,787 B2	7/2014	Manning
8,426,974 B2	4/2013	Linderman et al.	8,785,233 B2	7/2014	Loscutoff et al.
8,448,391 B2	5/2013	Botkin et al.	8,785,236 B2	7/2014	Harley et al.
8,448,652 B2	5/2013	Almy et al.	8,785,830 B2	7/2014	Judkins
8,449,238 B2	5/2013	Mulligan et al.	8,786,095 B2	7/2014	Linderman et al.
8,450,134 B2	5/2013	Ceuster et al.	8,790,957 B2	7/2014	Li et al.
8,450,985 B2	5/2013	Gray et al.	8,793,942 B2	8/2014	Almy et al.
8,451,638 B2	5/2013	Chapman et al.	8,796,061 B2	8/2014	Bunea
8,455,806 B2	6/2013	Judkins	8,796,535 B2	8/2014	Linderman
8,456,876 B2	6/2013	Chapman	8,796,884 B2	8/2014	Naiknaware et al.
8,460,963 B2	6/2013	Smith	8,802,486 B2	8/2014	Li et al.
8,461,813 B2	6/2013	Chapman	8,809,671 B2	8/2014	Linderman et al.
8,462,518 B2	6/2013	Marroquin et al.	8,815,631 B2	8/2014	Cousins
8,482,947 B2	7/2013	Chapman et al.	8,817,510 B2	8/2014	Esrain et al.
8,486,746 B2	7/2013	Rim et al.	8,818,924 B2	8/2014	Wayne et al.
8,492,253 B2	7/2013	Manning	8,822,257 B2	9/2014	Rim et al.
8,503,200 B2	8/2013	Chapman et al.	8,822,262 B2	9/2014	Loscutoff et al.
8,508,964 B2	8/2013	Gray et al.	8,822,812 B2	9/2014	Wares
8,516,754 B2	8/2013	Botkin et al.	8,823,356 B2	9/2014	Chapman
8,519,729 B2	8/2013	Capulong et al.	8,824,178 B1	9/2014	Baker et al.
D690,453 S	9/2013	Guercio et al.	8,839,784 B2	9/2014	Wares et al.
8,528,366 B2	9/2013	Sounni et al.	8,842,454 B2	9/2014	Johnson et al.
8,530,990 B2	9/2013	Linderman et al.	8,859,933 B2	10/2014	Harley et al.
8,534,007 B2	9/2013	Almy et al.	8,860,162 B2	10/2014	Linderman et al.
8,546,681 B2	10/2013	Wares et al.	8,860,242 B1	10/2014	Pruett et al.
8,548,637 B2	10/2013	Lenox	8,877,617 B2	11/2014	Wong et al.
8,552,288 B2	10/2013	Xavier	8,878,053 B2	11/2014	Cousins
8,557,093 B2	10/2013	Cousins et al.	8,881,415 B2	11/2014	Barton
8,558,101 B2	10/2013	Mascolo et al.	8,883,247 B2	11/2014	Cousins et al.
8,563,849 B2	10/2013	Johnston et al.	8,893,713 B2	11/2014	Wares et al.
8,567,134 B1	10/2013	Grushkowitz et al.	8,901,010 B2	12/2014	Westerberg et al.
8,572,836 B2	11/2013	Lenox	8,904,717 B2	12/2014	Lenox
8,580,599 B2	11/2013	Rim et al.	8,912,038 B2	12/2014	Li et al.
8,584,406 B2	11/2013	Wexler et al.	8,922,062 B2	12/2014	Johnson et al.
8,584,667 B2	11/2013	Linderman et al.	8,922,185 B2	12/2014	Ehlmann et al.
8,586,397 B2	11/2013	Wu et al.	8,929,094 B2	1/2015	Marroquin et al.
8,586,403 B2	11/2013	Harley et al.	8,943,765 B2	2/2015	Danning et al.
8,597,970 B2	12/2013	Cousins et al.	8,945,978 B2	2/2015	Behnke
8,599,587 B2	12/2013	Chapman et al.	8,946,541 B2	2/2015	Wares et al.
8,604,404 B1	12/2013	Linderman	8,955,267 B2	2/2015	Wexler et al.
8,609,977 B2	12/2013	Jones et al.	8,956,018 B2	2/2015	Deshpande et al.
8,611,107 B2	12/2013	Chapman et al.	8,962,082 B2	2/2015	Pavani et al.
8,615,941 B2	12/2013	Botkin et al.	8,962,373 B2	2/2015	Cousins et al.
8,624,561 B1	1/2014	Slavin	8,963,185 B2	2/2015	Cousins
8,624,621 B2	1/2014	Capulong et al.	8,963,375 B2	2/2015	DeGraaff
8,629,383 B2	1/2014	Beardsworth et al.	8,964,401 B2	2/2015	Escamilla et al.
8,630,077 B2	1/2014	Johnston et al.	8,975,175 B1	3/2015	Pass
8,634,216 B2	1/2014	Chapman	8,975,717 B2	3/2015	Smith
8,636,198 B1	1/2014	Linderman et al.	8,988,096 B1	3/2015	Naiknaware
8,647,911 B2	2/2014	Smith	8,991,682 B2	3/2015	Linderman et al.
8,650,813 B2	2/2014	Botkin et al.	8,992,803 B2	3/2015	Loscutoff et al.
8,656,660 B2	2/2014	Danning	9,010,041 B2	4/2015	Danning
			9,018,033 B2	4/2015	Wu et al.
			9,018,516 B2	4/2015	Shepherd et al.
			9,020,653 B2	4/2015	Lenox
			9,029,689 B2	5/2015	Phu et al.

(56)

References Cited

U.S. PATENT DOCUMENTS

9,035,167 B2	5/2015	Swanson et al.	9,281,431 B2	3/2016	Linderman
9,035,168 B2	5/2015	Barton	9,285,081 B2	3/2016	Douglas et al.
9,035,172 B2	5/2015	Kim et al.	9,293,624 B2	3/2016	Cudzinovic et al.
9,035,633 B1	5/2015	Slavin et al.	9,300,224 B2	3/2016	Johnson et al.
9,038,421 B2	5/2015	Sounni et al.	D754,064 S	4/2016	Mackler et al.
9,048,740 B2	6/2015	Gray et al.	9,303,285 B2	4/2016	Piazza et al.
9,054,255 B2	6/2015	Swanson et al.	9,306,085 B2	4/2016	Westerberg et al.
9,059,604 B2	6/2015	Johnson	9,312,042 B2	4/2016	Sewell et al.
9,062,854 B2	6/2015	Livesay et al.	9,312,406 B2	4/2016	Loscutoff et al.
9,065,354 B2	6/2015	Chapman et al.	9,312,425 B2	4/2016	Kim et al.
9,070,804 B2	6/2015	Cousins	9,316,417 B2	4/2016	Danning
9,077,202 B1	7/2015	Baker	9,322,437 B2	4/2016	Agullo
9,082,925 B2	7/2015	Solomon et al.	9,322,963 B2	4/2016	Linderman et al.
9,083,121 B2	7/2015	DeGraaff et al.	9,326,339 B2	4/2016	Nieberlein et al.
9,087,939 B2	7/2015	Harley et al.	9,328,427 B2	5/2016	Behnke
9,093,919 B2	7/2015	Chapman et al.	9,329,322 B2	5/2016	Yamada et al.
9,101,082 B1	8/2015	Dorenkamp et al.	9,337,369 B2	5/2016	Smith
9,112,066 B2	8/2015	Dennis et al.	9,342,088 B2	5/2016	Batten et al.
9,112,097 B2	8/2015	Tu	9,347,619 B2	5/2016	Schupple et al.
9,116,202 B2	8/2015	Capulong et al.	9,353,970 B2	5/2016	Linderman et al.
9,136,710 B1	9/2015	Baker et al.	9,362,427 B2	6/2016	Sewell et al.
9,142,696 B2	9/2015	Loscutoff et al.	D786,458 S *	5/2017	Wang D26/1
9,147,795 B2	9/2015	Li et al.	D802,805 S *	11/2017	Wong D26/1
9,153,712 B2	10/2015	Zhu	D814,666 S *	4/2018	Wang D26/1
9,159,521 B1	10/2015	Chen et al.	D836,218 S *	12/2018	Beghelli D26/1
9,160,408 B2	10/2015	Krohne et al.	2002/0181229 A1	12/2002	Wei
9,166,079 B2	10/2015	Manning	2011/0312119 A1	12/2011	Rose et al.
9,178,104 B2	11/2015	Moors et al.	2012/0134189 A1	5/2012	Krein et al.
9,184,324 B2	11/2015	Wares et al.	2012/0180845 A1	7/2012	Cole et al.
9,184,327 B2	11/2015	Rose et al.	2012/0192925 A1	8/2012	Grushkowitz et al.
9,185,759 B2	11/2015	Nieberlein et al.	2012/0216852 A1	8/2012	Almy et al.
9,186,741 B2	11/2015	Kumaria et al.	2013/0000694 A1	1/2013	Bunea et al.
9,190,839 B2	11/2015	Johnston et al.	2013/0106196 A1	5/2013	Johnson et al.
9,193,014 B2	11/2015	Danning	2013/0239947 A1	9/2013	Almy et al.
9,196,758 B2	11/2015	Rim et al.	2013/0255749 A1	10/2013	Kinyon et al.
D744,684 S	12/2015	Guercio et al.	2013/0305787 A1	11/2013	Berrada et al.
D744,690 S	12/2015	Boyer et al.	2013/0340379 A1	12/2013	Danning et al.
9,202,960 B2	12/2015	Luan et al.	2013/0340380 A1	12/2013	Danning et al.
9,212,808 B2	12/2015	Higley et al.	2014/0000187 A1	1/2014	Botkin et al.
9,217,206 B2	12/2015	Behnke et al.	2014/0000695 A1	1/2014	Stone et al.
9,219,173 B2	12/2015	Swanson et al.	2014/0000705 A1	1/2014	Sounni et al.
9,222,193 B2	12/2015	Abas et al.	2014/0014499 A1	1/2014	Cousins et al.
9,224,902 B2	12/2015	Swanson	2014/0034111 A1	2/2014	Bunea et al.
9,225,256 B2	12/2015	Chapman et al.	2014/0034122 A1	2/2014	Cousins et al.
9,225,285 B2	12/2015	Peurach et al.	2014/0034455 A1	2/2014	Mulligan et al.
D747,008 S *	1/2016	Kim D26/1	2014/0036563 A1	2/2014	Chapman et al.
9,231,129 B2	1/2016	Harley et al.	2014/0048119 A1	2/2014	Johnston et al.
9,231,145 B2	1/2016	Smith	2014/0090637 A1	4/2014	Grushkowitz
9,239,153 B2	1/2016	Goodman et al.	2014/0090638 A1	4/2014	Grushkowitz
9,240,682 B2	1/2016	Sivakumar et al.	2014/0090701 A1	4/2014	Rim et al.
9,243,818 B2	1/2016	Shugar et al.	2014/0102505 A1	4/2014	Lenox
9,246,037 B2	1/2016	Linderman	2014/0102512 A1	4/2014	Jones et al.
9,246,046 B1	1/2016	Harrington et al.	2014/0116495 A1	5/2014	Kim et al.
9,249,044 B2	2/2016	Judkins et al.	2014/0133197 A1	5/2014	Chapman et al.
9,249,523 B2	2/2016	Rim	2014/0150846 A1	6/2014	Beardsworth et al.
9,252,314 B2	2/2016	Wares et al.	2014/0174905 A1	6/2014	Landry
9,252,319 B2	2/2016	Loscutoff et al.	2014/0182661 A1	7/2014	Kinyon
9,253,935 B2	2/2016	Morris et al.	2014/0190561 A1	7/2014	De et al.
9,257,575 B1	2/2016	Pass et al.	2014/0202492 A1	7/2014	Grossman et al.
9,257,847 B2	2/2016	Johnson et al.	2014/0238470 A1	8/2014	Ciasulli et al.
9,263,183 B2	2/2016	Chapman et al.	2014/0261626 A1	9/2014	Ripoll et al.
9,263,601 B2	2/2016	Wu et al.	2014/0268908 A1	9/2014	Zhou et al.
9,263,602 B2	2/2016	Harley et al.	2014/0290715 A1	10/2014	Meydbray et al.
9,263,622 B2	2/2016	Pass et al.	2014/0291852 A1	10/2014	Linderman et al.
9,263,625 B2	2/2016	Smith et al.	2014/0305501 A1	10/2014	Li et al.
9,263,895 B2	2/2016	Naiknaware et al.	2014/0306092 A1	10/2014	Judkins
9,266,468 B2	2/2016	Mizushiro et al.	2014/0311054 A1	10/2014	Concho et al.
9,267,649 B2	2/2016	Janik et al.	2014/0322855 A1	10/2014	Bunea et al.
D751,976 S	3/2016	Mackler et al.	2014/0345688 A1	11/2014	Cousins et al.
9,273,845 B2	3/2016	Eom et al.	2014/0352761 A1	12/2014	Linderman et al.
9,276,635 B2	3/2016	Rothblum et al.	2014/0373910 A1	12/2014	Luan et al.
9,279,457 B2	3/2016	Grushkowitz	2015/0000724 A1	1/2015	Pass et al.
9,279,569 B2	3/2016	Lamonato et al.	2015/0004737 A1	1/2015	Harley et al.
9,281,419 B2	3/2016	Klein et al.	2015/0020867 A1	1/2015	Linderman et al.
9,281,429 B2	3/2016	Xavier et al.	2015/0040944 A1	2/2015	Dinwoodie et al.
			2015/0047690 A1	2/2015	Shen et al.
			2015/0053248 A1	2/2015	Rim et al.
			2015/0083215 A1	3/2015	Cousins
			2015/0090328 A1	4/2015	Smith

(56)

References Cited

U.S. PATENT DOCUMENTS

2015/0090329 A1 4/2015 Pass et al.
 2015/0108692 A1 4/2015 Harley et al.
 2015/0117067 A1 4/2015 Naiknaware et al.
 2015/0122305 A1 5/2015 Marroquin et al.
 2015/0128437 A1 5/2015 Barton
 2015/0144197 A1 5/2015 Cousins et al.
 2015/0146315 A1 5/2015 Wares et al.
 2015/0155819 A1 6/2015 Wexler et al.
 2015/0163074 A1 6/2015 Pruett et al.
 2015/0180238 A1 6/2015 Degraaff et al.
 2015/0180404 A1 6/2015 Braunstein et al.
 2015/0194539 A1 7/2015 Shepherd et al.
 2015/0194927 A1 7/2015 Naiknaware et al.
 2015/0206988 A1 7/2015 Loscutoff et al.
 2015/0212535 A1 7/2015 Ehlmann et al.
 2015/0214744 A1 7/2015 Lenox
 2015/0222225 A1 8/2015 Danning
 2015/0229221 A1 8/2015 Gray et al.
 2015/0249405 A1 9/2015 Chapman et al.
 2015/0249423 A1 9/2015 Braunstein et al.
 2015/0263200 A1 9/2015 Dennis et al.
 2015/0270803 A1 9/2015 Barton et al.
 2015/0280038 A1 10/2015 Sethi et al.
 2015/0282365 A1 10/2015 Escamilla et al.
 2015/0287875 A1 10/2015 Phu et al.
 2015/0288328 A1 10/2015 Swanson et al.
 2015/0311357 A1 10/2015 Harley et al.
 2015/0325710 A1 11/2015 Tu et al.
 2015/0326168 A1 11/2015 Johnson et al.
 2015/0326178 A1 11/2015 Capulong et al.
 2015/0333617 A1 11/2015 Chapman et al.
 2015/0340868 A1 11/2015 Chapman et al.
 2015/0342084 A1 11/2015 Dorenkamp et al.
 2015/0349158 A1 12/2015 Manning
 2015/0349706 A1 12/2015 Grossman et al.
 2015/0349709 A1 12/2015 Ponec et al.

2015/0364625 A1 12/2015 Solomon et al.
 2015/0372638 A1 12/2015 Degraaff et al.
 2015/0377518 A1 12/2015 Maxey et al.
 2015/0380578 A1 12/2015 Zhu et al.
 2016/0011246 A1 1/2016 Fischer et al.
 2016/0020827 A1 1/2016 Krohne et al.
 2016/0027953 A1 1/2016 Moors et al.
 2016/0028345 A1 1/2016 Wares et al.
 2016/0035908 A1 2/2016 Rose et al.
 2016/0036380 A1 2/2016 Johnston et al.
 2016/0043267 A1 2/2016 Rim et al.
 2016/0043684 A1 2/2016 Harif
 2016/0064576 A1 3/2016 Luan et al.
 2016/0065119 A1 3/2016 Danning et al.
 2016/0071991 A1 3/2016 Smith et al.
 2016/0071996 A1 3/2016 Swanson et al.
 2016/0071999 A1 3/2016 Loscutoff et al.
 2016/0079450 A1 3/2016 Harley et al.
 2016/0079911 A1 3/2016 Rose et al.
 2016/0087425 A1 3/2016 Sivakumar et al.
 2016/0090662 A1 3/2016 Capulong et al.
 2016/0105027 A1 4/2016 Johnson et al.
 2016/0108541 A1 4/2016 Abas et al.
 2016/0111583 A1 4/2016 Harrington et al.
 2016/0112003 A1 4/2016 Morris et al.
 2016/0118516 A1 4/2016 Harley et al.
 2016/0133759 A1 5/2016 Pass et al.
 2016/0133767 A1 5/2016 Smith et al.
 2016/0134233 A1 5/2016 Chapman et al.
 2016/0142100 A1 5/2016 Rothblum et al.
 2016/0156309 A1 6/2016 Almogy et al.
 2016/0164300 A1 6/2016 Johnson et al.
 2016/0164427 A1 6/2016 Chapman et al.

OTHER PUBLICATIONS

Flex Lighting Solutions Specification Sheets, Essentials Series,
 Published May 2017 (9 pages).

* cited by examiner

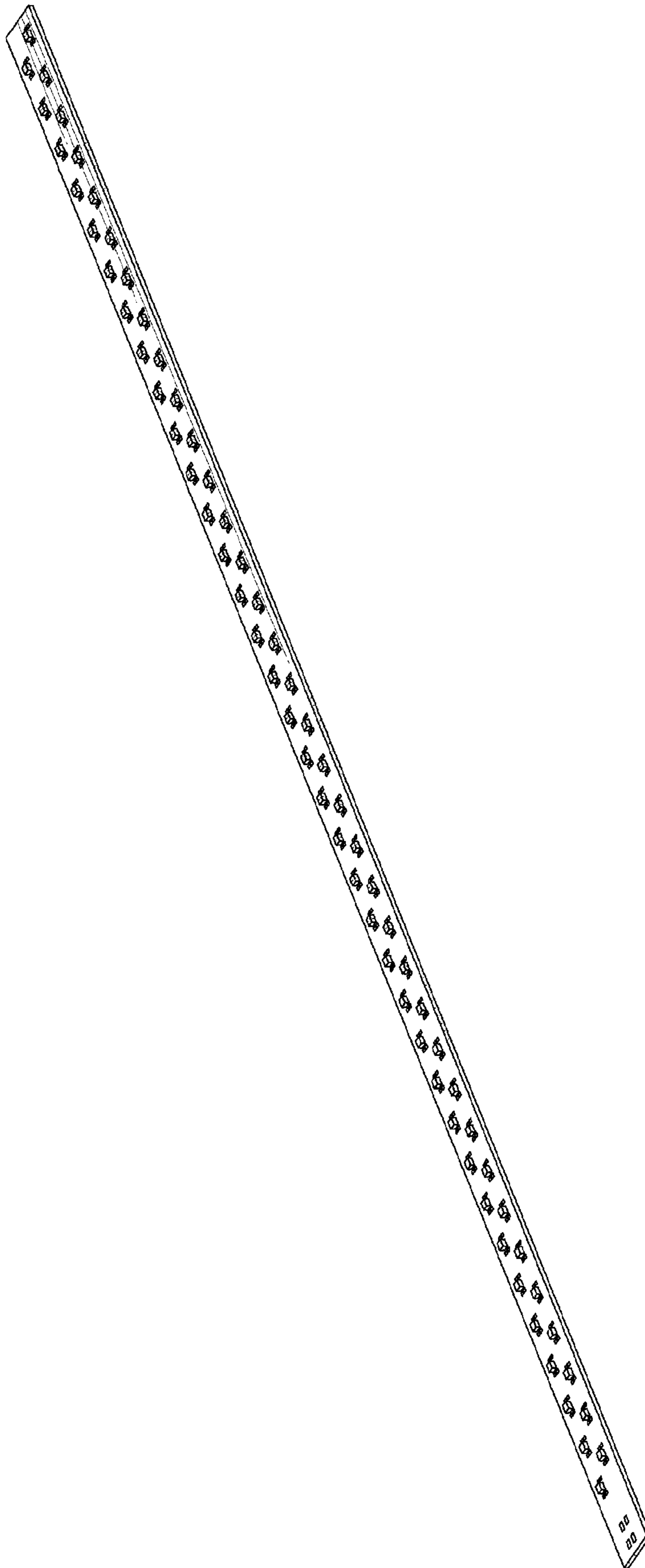

FIG. 1



FIG. 3

FIG. 2

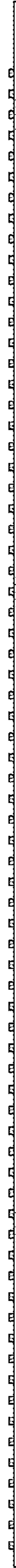

FIG. 4

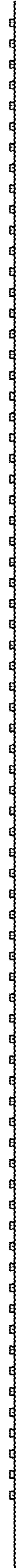

FIG. 5

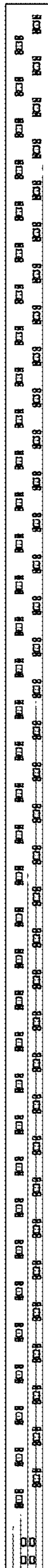

FIG. 6

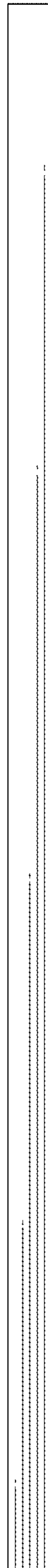

FIG. 7

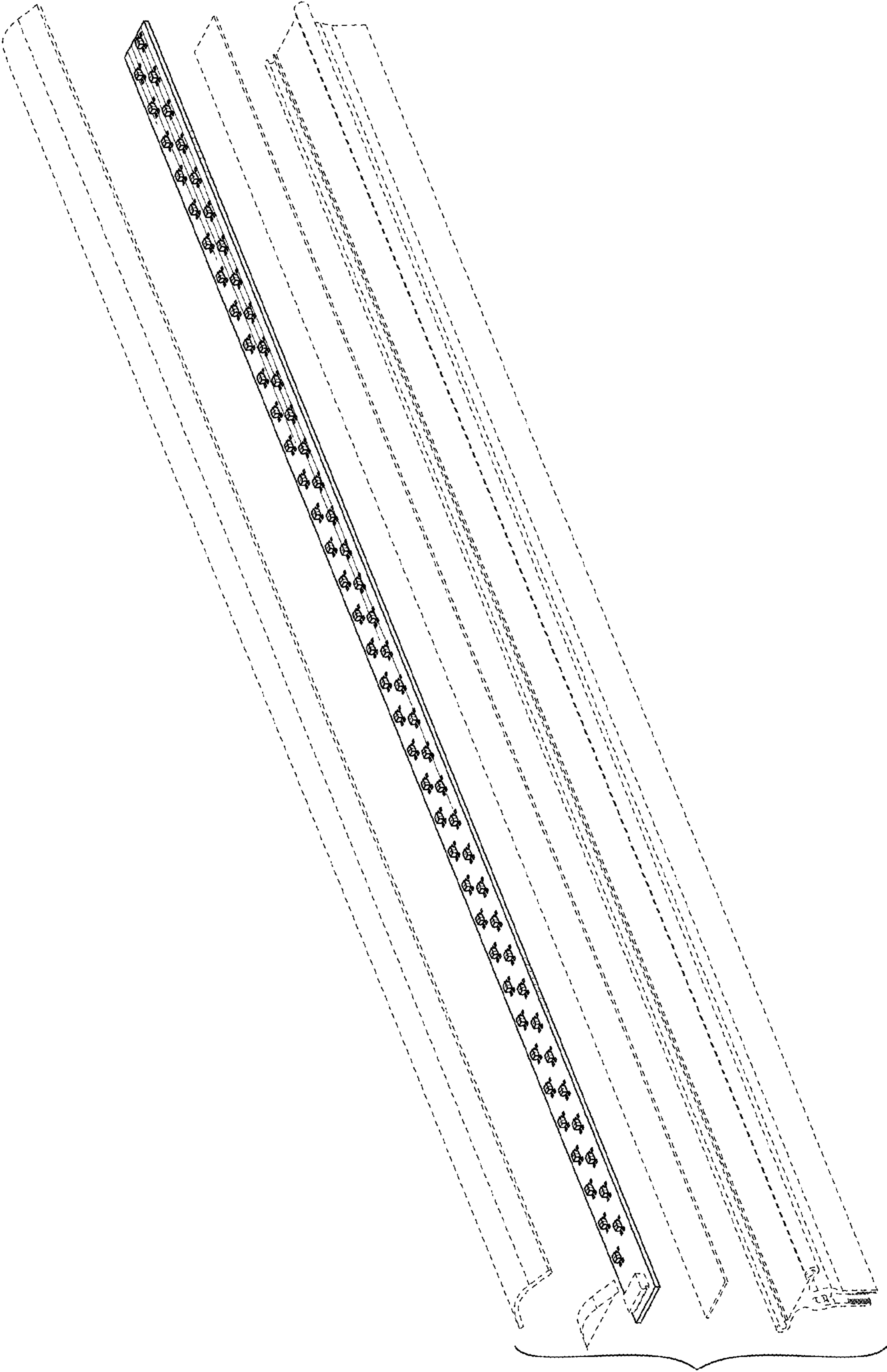

FIG. 8