



US00D885010S

(12) **United States Design Patent**  
**Macklin**

(10) **Patent No.:** **US D885,010 S**

(45) **Date of Patent:** **\*\* May 26, 2020**

(54) **ADAPTIVE PANTS**

*Primary Examiner — Amy C Wierenga*

(71) Applicant: **Carla Macklin**, Shaker Heights, OH  
(US)

(57) **CLAIM**

The ornamental design for adaptive pants, as shown and described.

(72) Inventor: **Carla Macklin**, Shaker Heights, OH  
(US)

(\*\*) Term: **15 Years**

**DESCRIPTION**

(21) Appl. No.: **29/657,601**

FIG. 1 is a front plan view of a pair of adaptive pants showing my new design;

(22) Filed: **Jul. 24, 2018**

FIG. 2 is a rear plan view of the adaptive pants of FIG. 1;

(51) **LOC (12) Cl.** ..... **02-02**

FIG. 3 is a right side view of the adaptive pants of FIG. 1, with one leg bent;

(52) **U.S. Cl.**

USPC ..... **D2/742**

FIG. 4 is a left side view of the adaptive pants of FIG. 1, with one leg bent;

(58) **Field of Classification Search**

USPC ..... D2/712-713, 731, 738, 742-745, 747,  
D2/853, 857, 999, 716, 728, 732; 2/78.2,  
2/79, 227, 404-408

FIG. 5 is a top plan view of the wrap-around waist opening of the adaptive pants of FIG. 1;

CPC ..... **A41D 11/00**

FIG. 6 is a perspective front cut-away view of the waist opening of the adaptive pants of FIG. 5;

See application file for complete search history.

FIG. 7 is a bottom plan view of leg openings of the adaptive pants of FIG. 1;

(56) **References Cited**

**U.S. PATENT DOCUMENTS**

2,923,009	A *	2/1960	Cookman	.....	A41D 1/06	2/227
3,800,330	A	4/1974	Bowcut			
D255,168	S *	6/1980	Taylor	.....	D2/742	
D279,041	S *	6/1985	Sears	.....	D2/742	
5,008,962	A *	4/1991	Smith	.....	A41D 1/06	2/227
5,010,595	A	4/1991	Stradley			
5,084,914	A *	2/1992	Hesch	.....	A41D 13/129	2/227
5,097,535	A *	3/1992	Dye	.....	A41D 10/00	2/104
5,163,182	A	11/1992	Fiveash			
5,191,659	A	3/1993	Backus			
5,473,780	A	12/1995	Zen			
5,535,450	A	7/1996	Melzer			

FIG. 8 is a front plan cut-away view of the adaptive pants shown in FIG. 1, with the right side waist opening shown open;

FIG. 9 is a front plan cut-away view of the adaptive pants shown in FIG. 1, with the left side waist opening shown open;

FIG. 10 is a full front plan view of the adaptive pants shown in FIG. 9, with the left side waist and front leg opening shown open; and,

FIG. 11 is a full front plan view of the adaptive pants shown in FIG. 10, but with both the right left side waist and leg openings shown open.

In the drawings, the broken lines shown are for the purpose of illustrating portions of the adaptive pants that form no part of the claim. The dot dash broken line indicates cutoff boundaries for enlarged detailed portion view FIG. 6 and form no part of the claim.

(Continued)

**1 Claim, 4 Drawing Sheets**

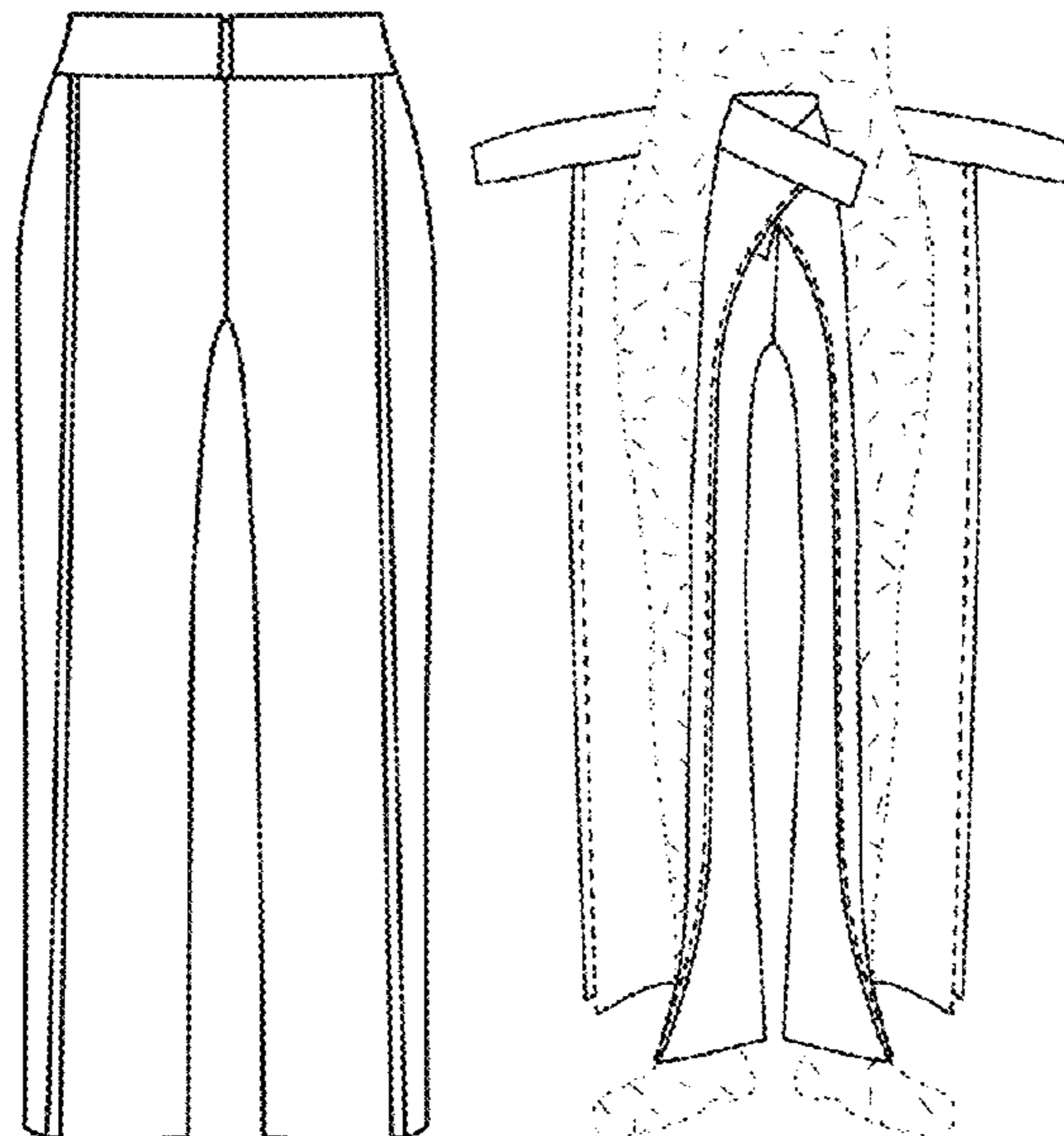

(56)

## References Cited

## U.S. PATENT DOCUMENTS

5,822,802 A \* 10/1998 Chou ..... A41D 13/1254  
2/227  
6,067,538 A 3/2000 Alleyne  
6,260,209 B1 7/2001 Ange  
6,477,716 B2 \* 11/2002 Blaire ..... A41D 1/06  
2/227  
D466,676 S \* 12/2002 Lyden ..... D2/742  
D512,550 S \* 12/2005 Dureus ..... D2/737  
D513,660 S \* 1/2006 Greene ..... D2/742  
D520,213 S \* 5/2006 Dureus ..... D2/737  
D548,929 S \* 8/2007 Dureus ..... D2/743  
D572,433 S 7/2008 Peters  
D575,028 S \* 8/2008 Patton ..... D2/742  
D613,038 S \* 4/2010 Viola ..... D2/742  
D614,378 S 4/2010 Viola et al.  
D622,935 S \* 9/2010 Jackson ..... D2/742  
D630,415 S 1/2011 Nunn  
7,966,672 B1 \* 6/2011 Hagerman ..... A41D 13/02  
2/227  
D655,070 S \* 3/2012 Gosse ..... D2/742  
8,464,365 B1 \* 6/2013 Nunn ..... A41D 1/08  
2/227  
D698,520 S 2/2014 Anderson et al.  
D771,909 S \* 11/2016 Robinson ..... D2/742  
D787,155 S 5/2017 Eisenhuth  
9,918,500 B2 2/2018 Tempesta  
1,000,464 A1 6/2018 Kuo  
2001/0004771 A1 \* 6/2001 Chou ..... A41D 1/007  
2/227  
2002/0040496 A1 \* 4/2002 Blaire ..... A41D 1/06  
2/227  
2013/0007939 A1 1/2013 Martinez  
2017/0181483 A1 \* 6/2017 Eisenhuth ..... A41D 1/06  
2019/0174846 A1 \* 6/2019 Puzzo ..... A41D 13/1254

\* cited by examiner

Figure 1

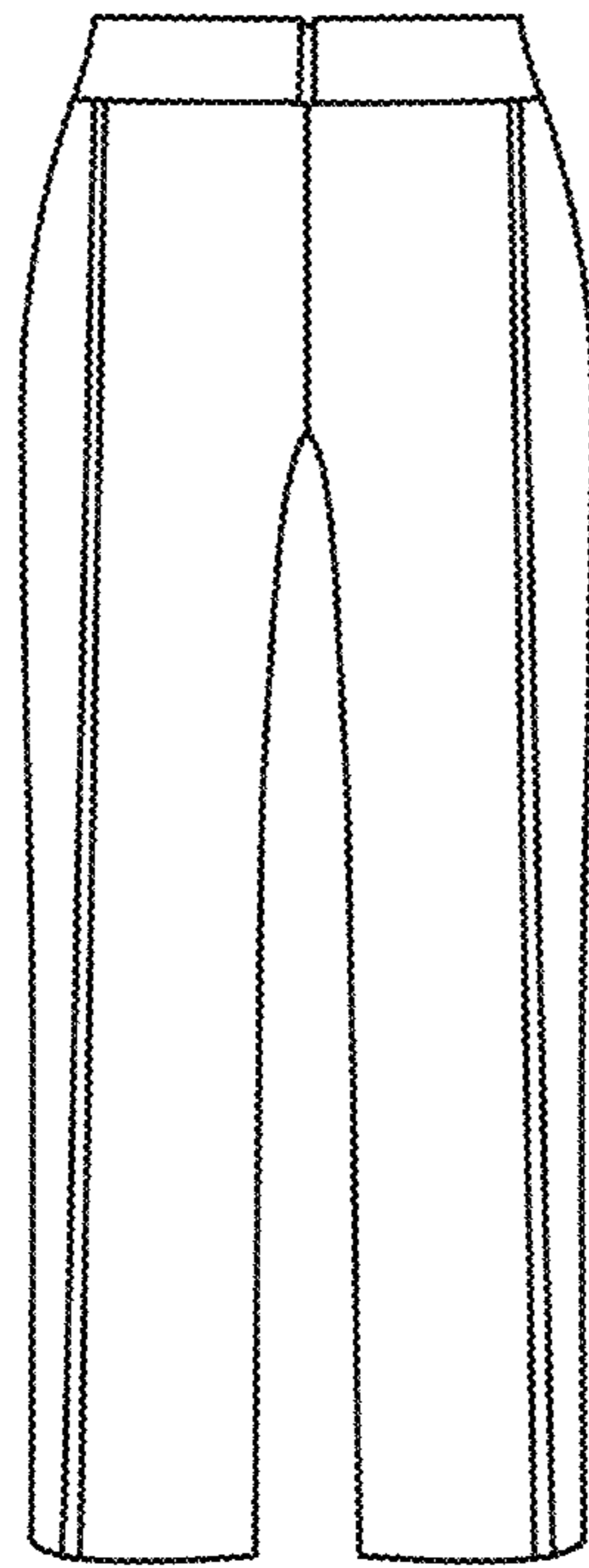

Figure 2

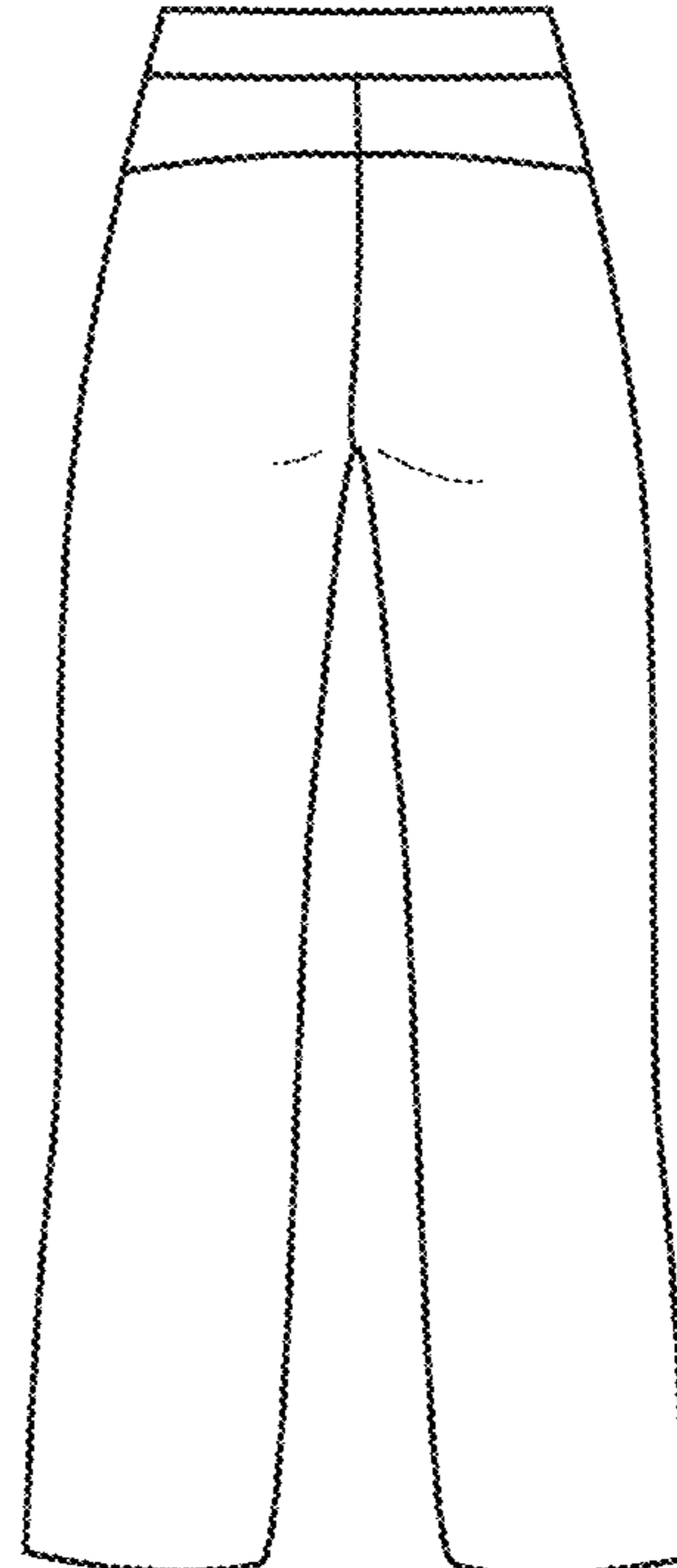

Figure 3

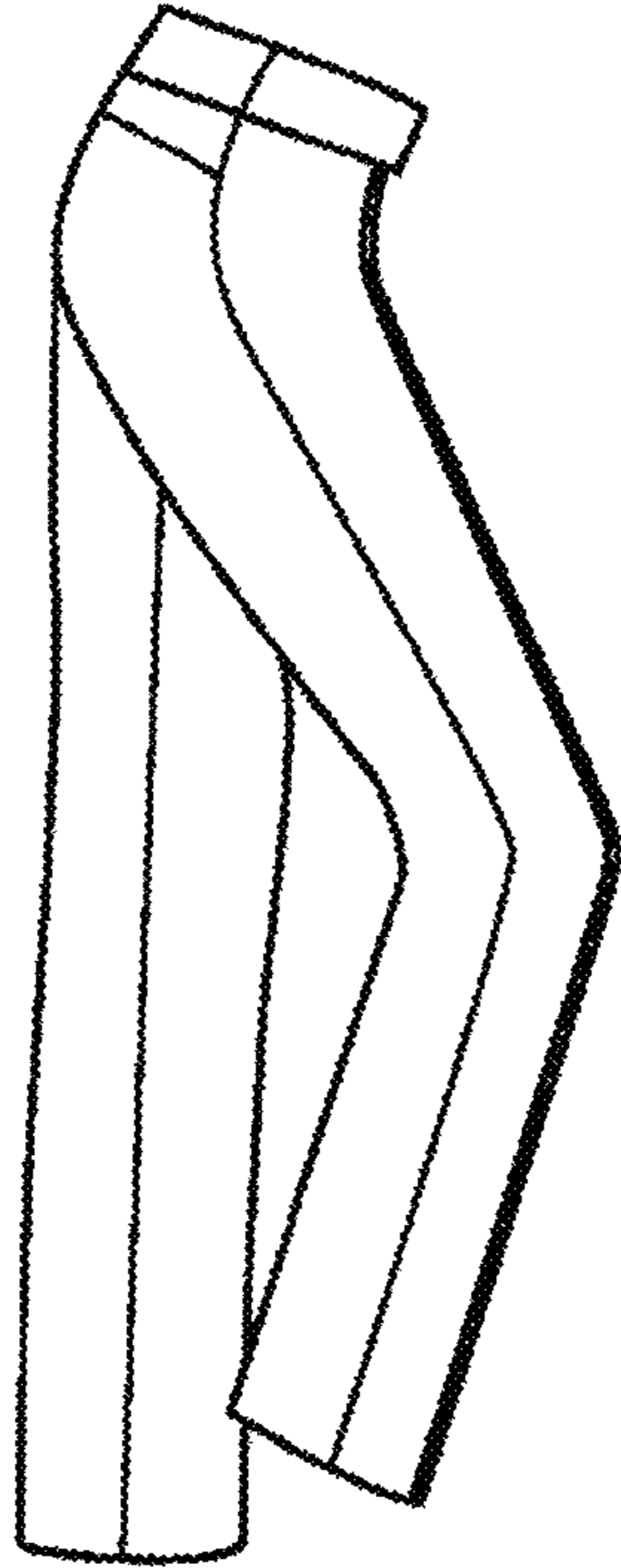

Figure 4

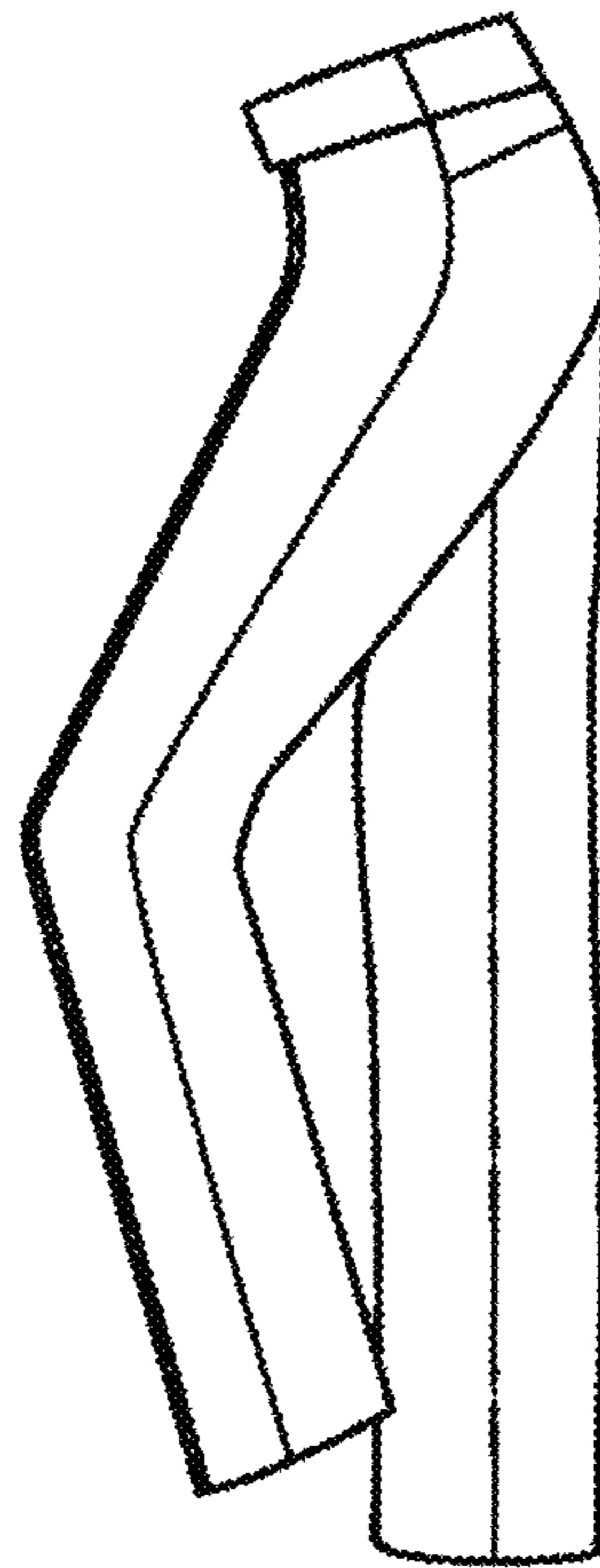

Figure 5

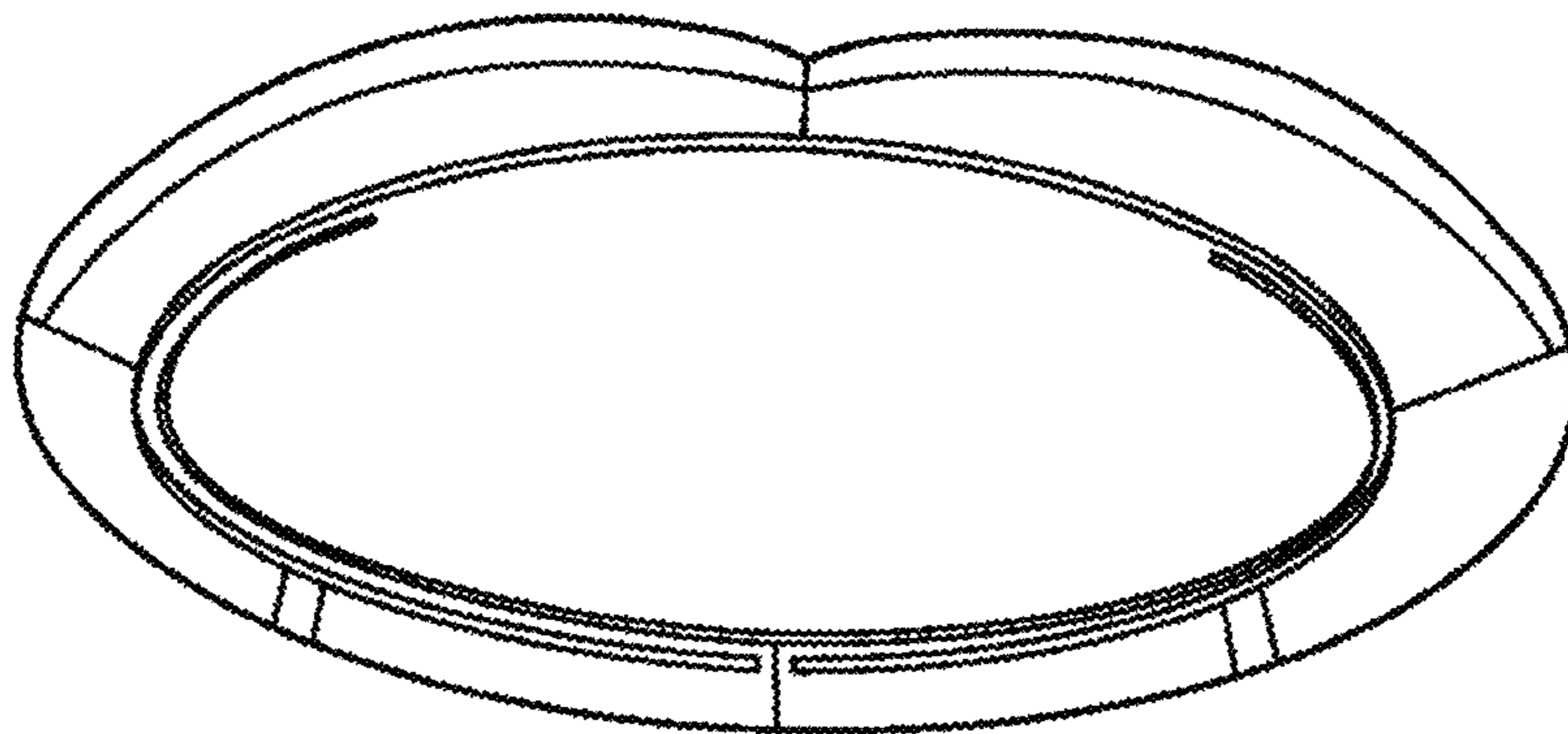

Figure 6

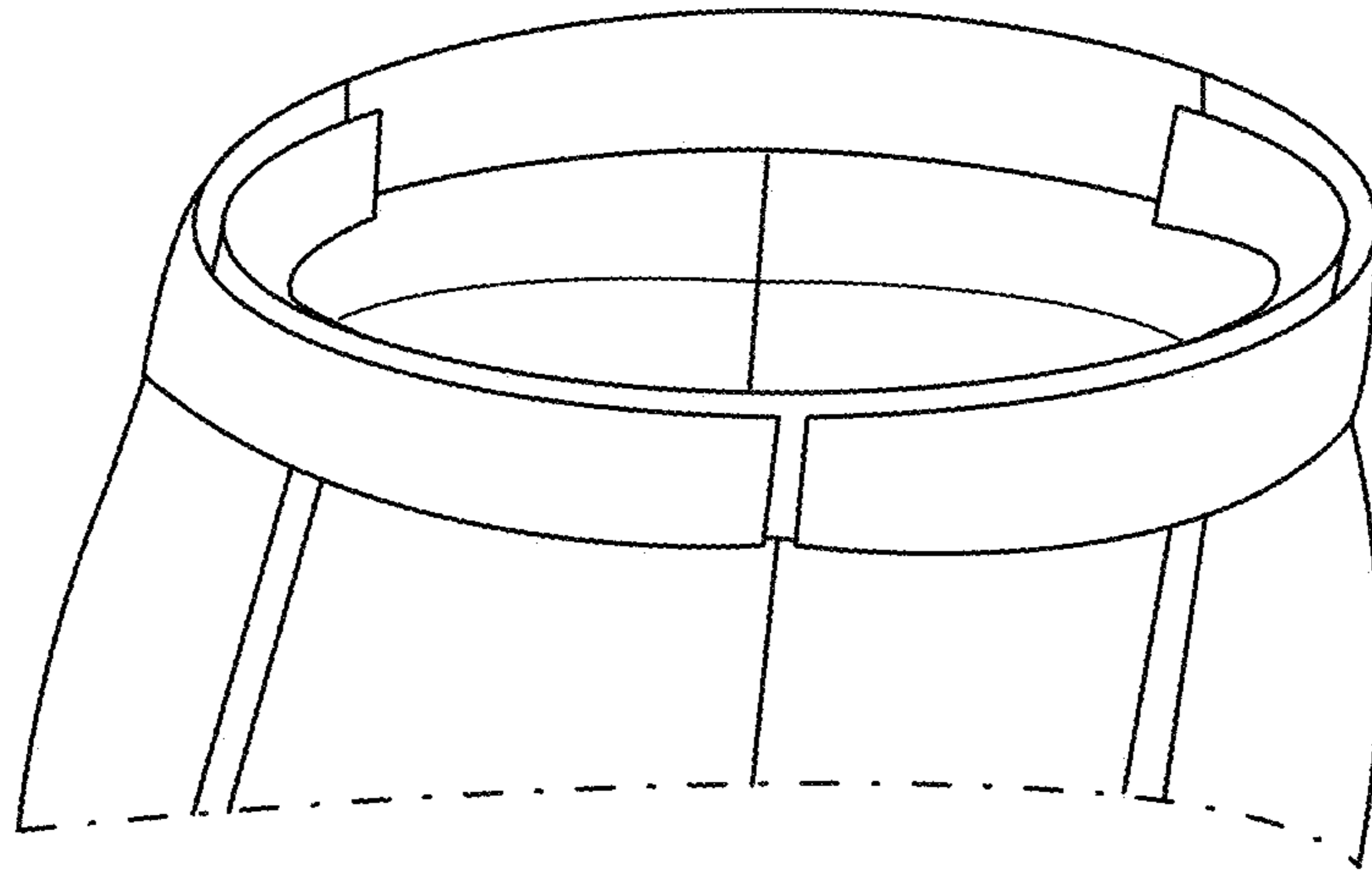

Figure 7

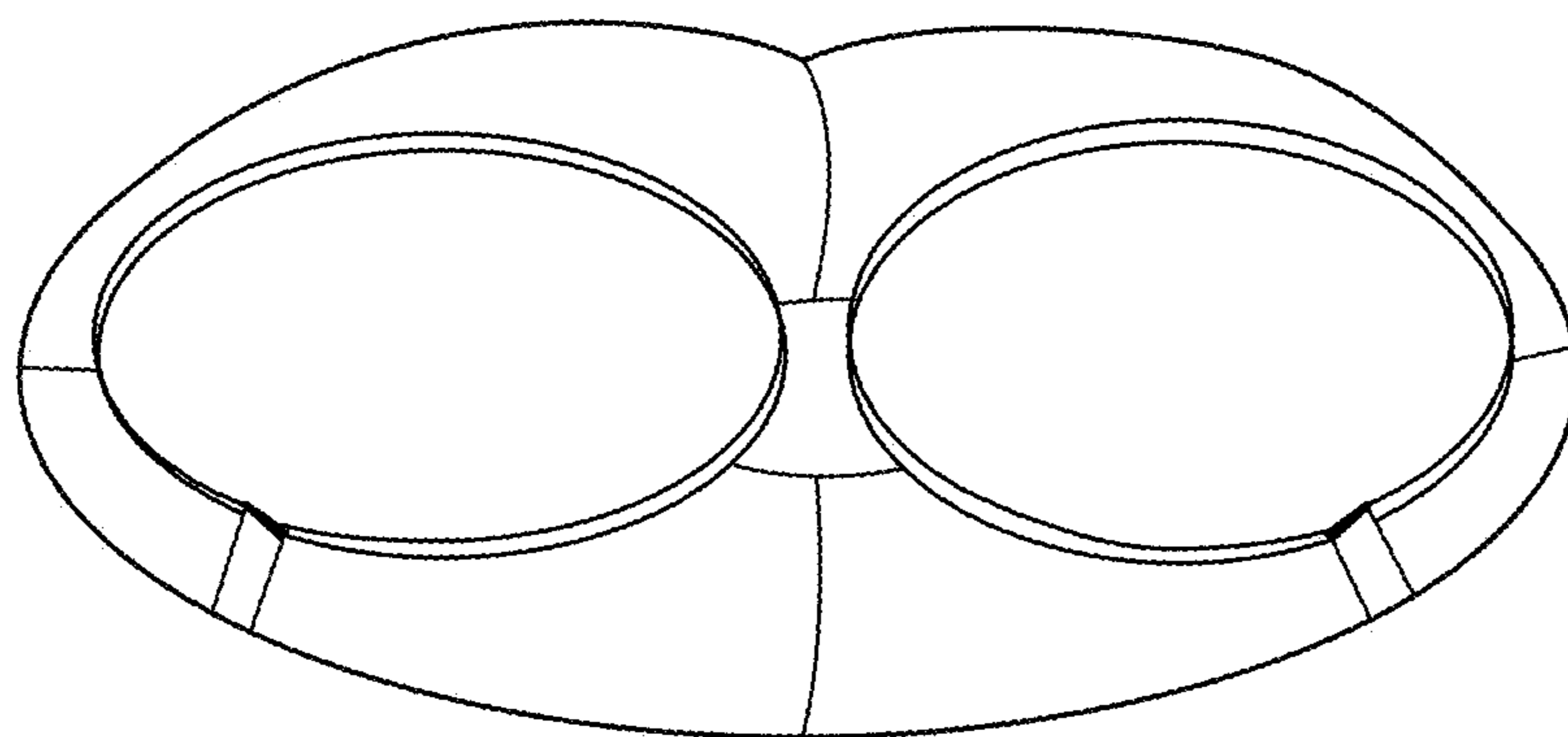

Figure 8

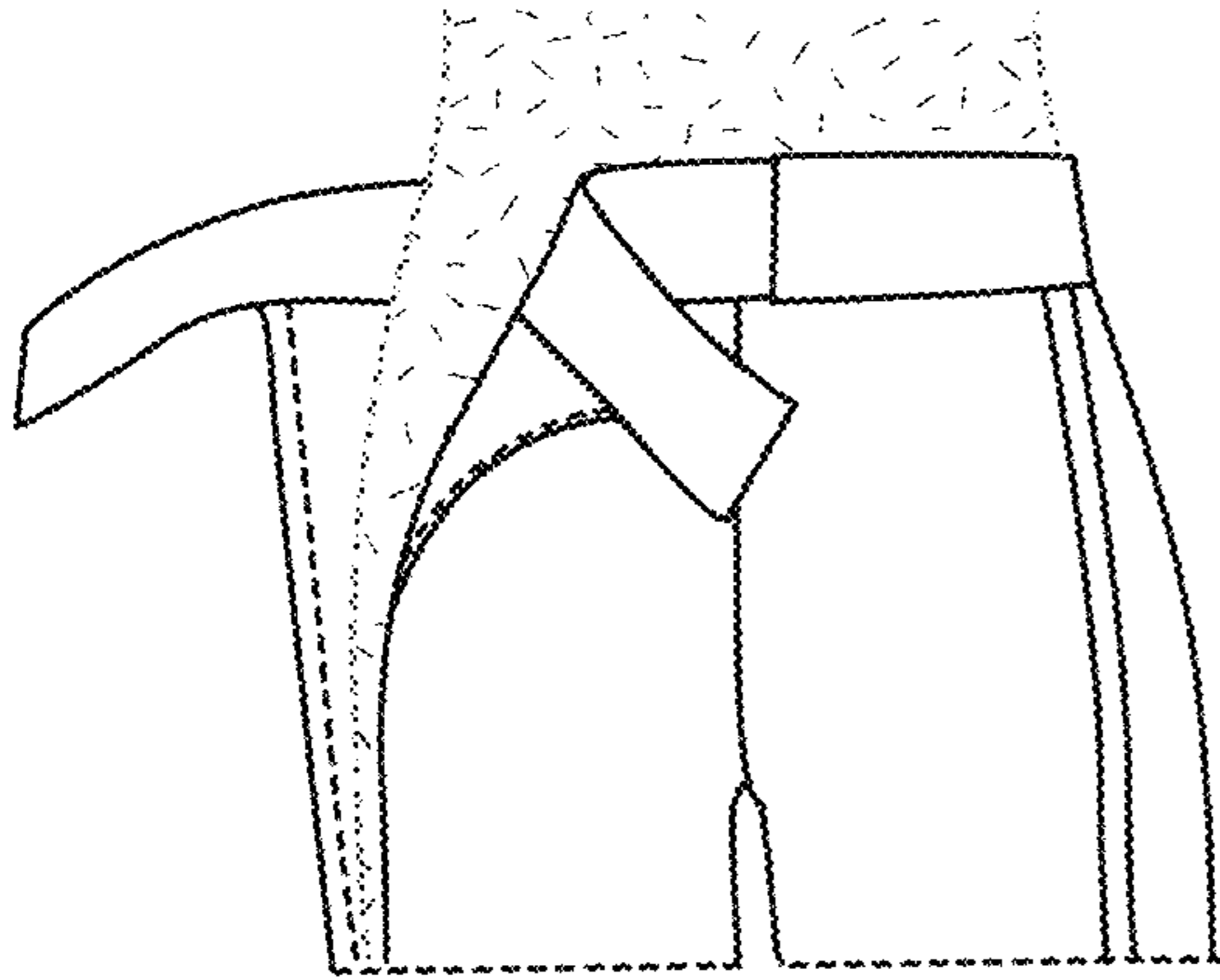

Figure 9

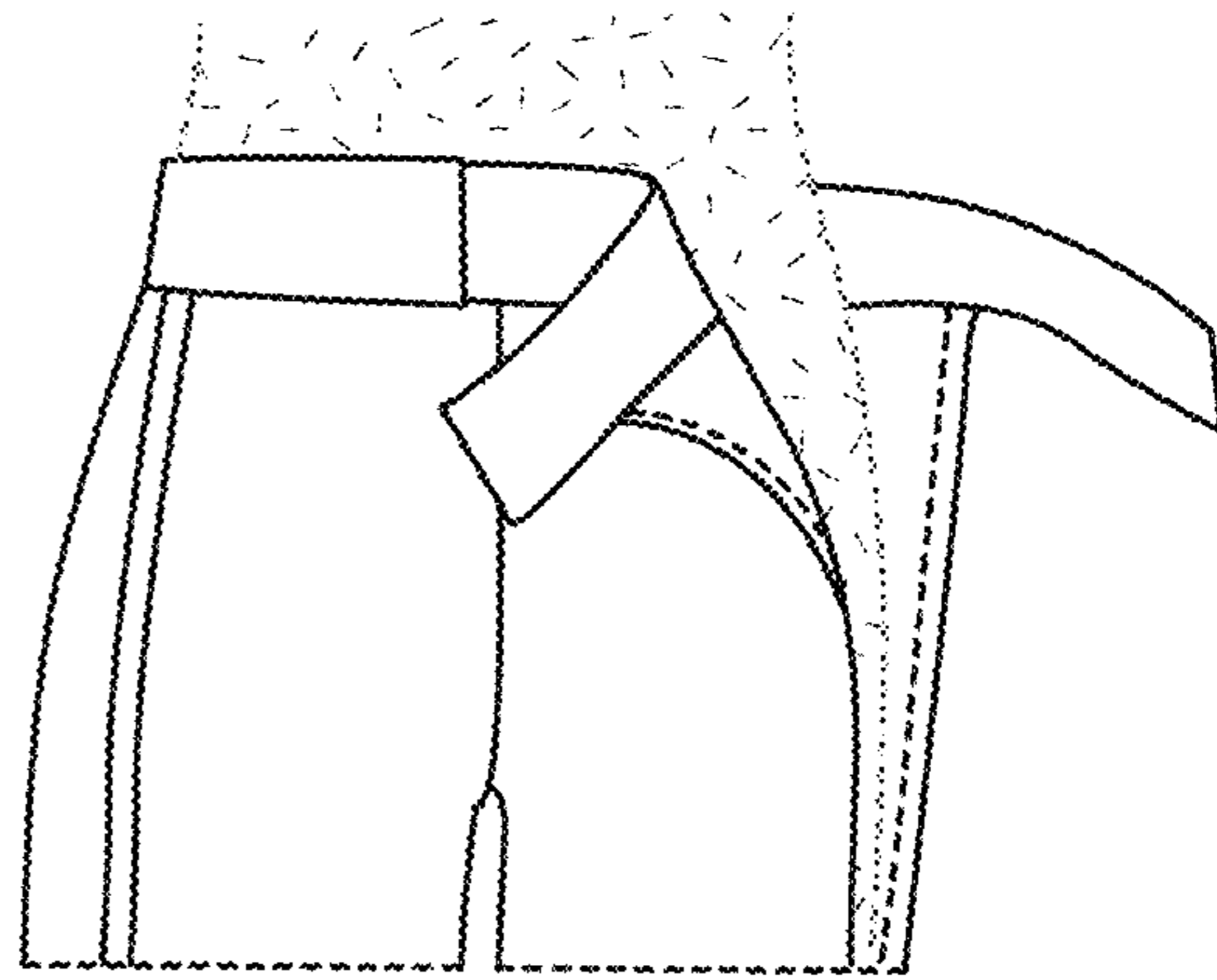

Figure 10

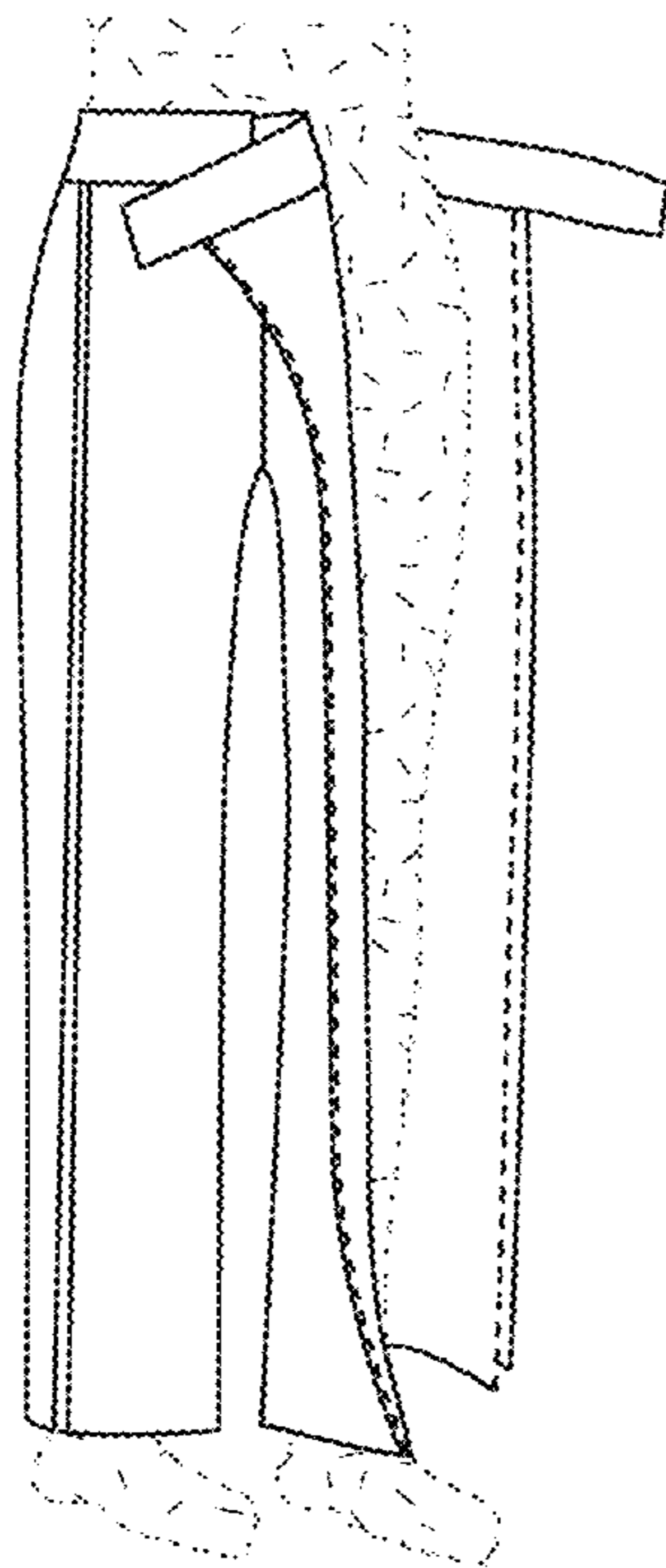

Figure 11

