



US00D884932S

(12) **United States Design Patent** (10) **Patent No.:** **US D884,932 S**  
**Howse** (45) **Date of Patent:** **\*\* May 19, 2020**

(54) **HEADLIGHT ASSEMBLY PAIR**

(71) Applicant: **McLaren Automotive Limited**,  
Woking (GB)  
(72) Inventor: **Paul Howse**, Shackleford (GB)  
(73) Assignee: **McLaren Automotive Limited**, Surrey  
(GB)  
(\*\*) Term: **15 Years**  
(21) Appl. No.: **29/594,821**  
(22) Filed: **Feb. 22, 2017**

(30) **Foreign Application Priority Data**

Aug. 22, 2016 (GB) ..... 6000145  
(51) **LOC (12) Cl.** ..... **26-06**  
(52) **U.S. Cl.**  
USPC ..... **D26/28**  
(58) **Field of Classification Search**  
USPC ..... D26/28, 29, 30, 31, 32, 33, 34, 35, 36;  
362/459-468, 475-478, 485-487  
CPC ..... F21S 48/00; F21S 48/10; F21S 48/115;  
F21S 48/225; F21S 48/1233; F21S  
48/1266; F21S 48/1388; F21S 48/2268;  
F21V 21/04  
See application file for complete search history.

(56) **References Cited**

**U.S. PATENT DOCUMENTS**

D217,599 S 5/1970 Abarth  
D361,046 S 8/1995 Watkins et al.  
(Continued)

**FOREIGN PATENT DOCUMENTS**

EM 0016089360001 3/2010  
EM 0020670330001 4/2012  
(Continued)

**OTHER PUBLICATIONS**

Lamborghini Gallardo Launched at Geneva Motor Show; [http://www.carpages.co.uk/lamborghini/lamborghini\\_gallardo\\_part\\_1\\_24\\_03\\_03.asp](http://www.carpages.co.uk/lamborghini/lamborghini_gallardo_part_1_24_03_03.asp); Mar. 24, 2003; 5 pages.  
(Continued)

*Primary Examiner* — Angela J Lee  
(74) *Attorney, Agent, or Firm* — Haynes Beffel & Wolfeld LLP; Andrew L. Dunlap

(57) **CLAIM**

The ornamental design for a headlight assembly pair, as shown and described.

**DESCRIPTION**

FIG. 1 is a front, left-side perspective view of the headlight assembly pair showing my new design;  
FIG. 2 is an enlarged perspective view of the left headlight assembly of the headlight assembly pair, shown separately for clarity of illustration;  
FIG. 3 is a left side elevation view of the headlight assembly pair of FIG. 1;  
FIG. 4 is an enlarged left side elevation view of the left headlight assembly of the headlight assembly pair, shown separately for clarity of illustration;  
FIG. 5 is a right side elevation view of the headlight assembly pair of FIG. 1;  
FIG. 6 is a top plan view of the headlight assembly pair of FIG. 1;  
FIG. 7 is an enlarged top plan view of the left headlight assembly of the headlight assembly pair, shown separately for clarity of illustration;  
FIG. 8 is a front elevation view of the headlight assembly pair of FIG. 1; and,  
FIG. 9 is an enlarged front elevation view of the left headlight assembly of the headlight assembly pair, shown separately for clarity of illustration.  
The invention is shown together with environmental structure in broken lines, the environmental structure forming no part of the claimed design.

**1 Claim, 9 Drawing Sheets**

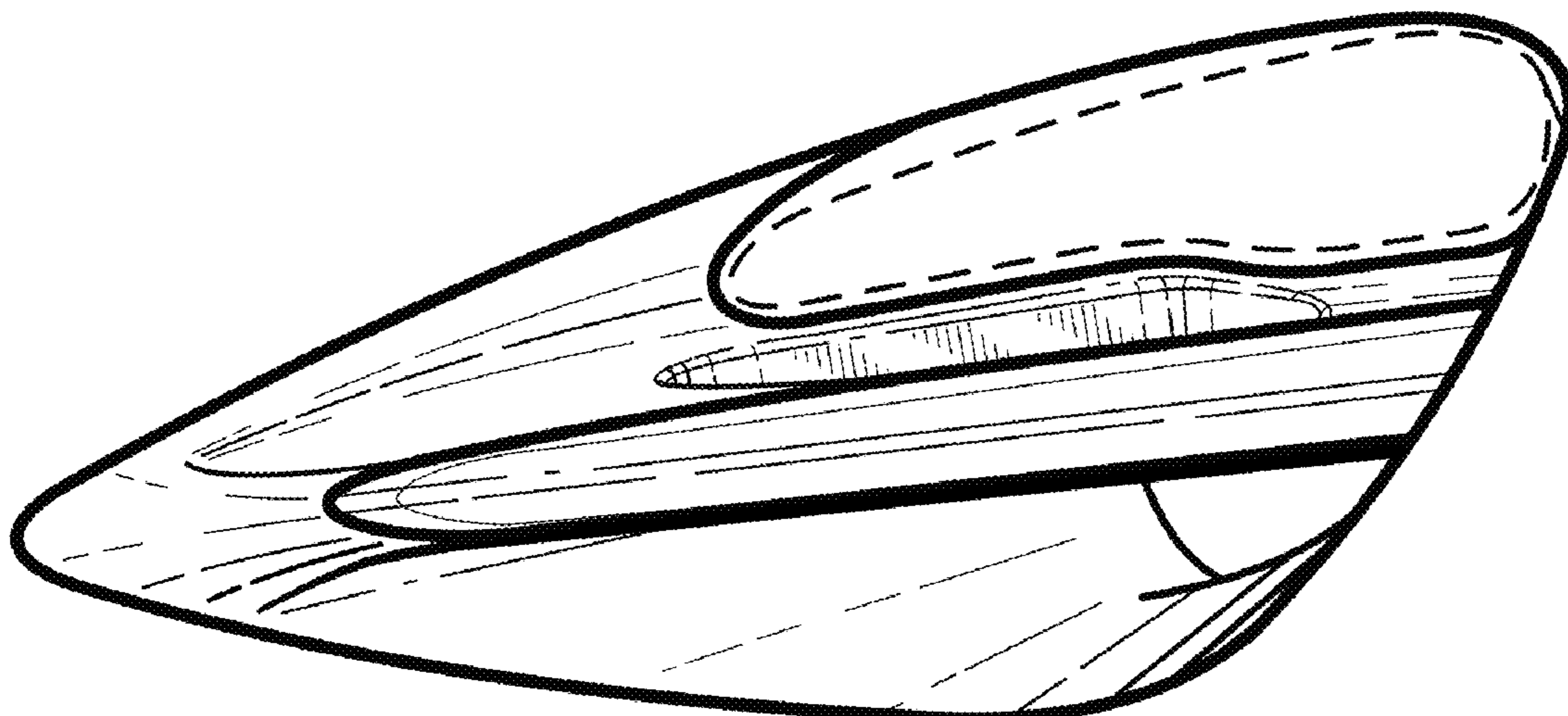



(56)

References Cited

OTHER PUBLICATIONS

U.S. PATENT DOCUMENTS

D455,984 S 4/2002 Boulay et al.  
 D478,843 S 8/2003 Pardo  
 D491,843 S 6/2004 Giugiaro  
 D495,071 S 8/2004 Pfeiffer  
 D498,010 S 11/2004 Pfeiffer et al.  
 D499,822 S 12/2004 Pfeiffer  
 D506,161 S 6/2005 Stephenson  
 D507,992 S 8/2005 Stephenson  
 D508,136 S 8/2005 Pfeiffer  
 D508,744 S 8/2005 Pfeiffer et al.  
 D508,745 S 8/2005 Pfeiffer et al.  
 D515,716 S 2/2006 Ikeda et al.  
 D517,228 S 3/2006 Pfeiffer et al.  
 D526,599 S 8/2006 Moruzzi  
 D527,138 S 8/2006 Golden et al.  
 D546,486 S 7/2007 Sinkwitz  
 D551,126 S 9/2007 Manfredini  
 D554,780 S 11/2007 Sinkwitz  
 D558,906 S 1/2008 Golden et al.  
 D566,864 S 4/2008 Pfeiffer  
 D586,011 S 2/2009 Pfeiffer  
 D587,629 S 3/2009 Crijns  
 D587,825 S 3/2009 Murkett  
 D589,403 S 3/2009 Saracoglu  
 D593,001 S 5/2009 Crijns  
 D599,922 S 9/2009 Pfeiffer  
 D608,696 S 1/2010 Bauer et al.  
 D612,769 S 3/2010 Cimatti  
 D617,018 S 6/2010 Schell et al.  
 D617,683 S 6/2010 Beneggi  
 D626,478 S 11/2010 Stephenson  
 D628,124 S 11/2010 Stephenson  
 D628,526 S 12/2010 Stephenson  
 D634,867 S 3/2011 Frenzel et al.  
 D636,102 S 4/2011 Matei et al.  
 D637,112 S 5/2011 Saracoglu  
 D643,558 S 8/2011 Antoniadis et al.  
 D645,176 S \* 9/2011 Bauer ..... D26/28  
 D648,662 S 11/2011 Stephenson  
 D658,318 S 4/2012 Futschik et al.  
 D659,593 S 5/2012 Robinson  
 D660,473 S 5/2012 Frenzel et al.  
 D664,475 S 7/2012 Takahashi  
 D670,203 S 11/2012 Weil  
 D671,457 S 11/2012 Goto et al.  
 D684,897 S 6/2013 Kim  
 D704,596 S 5/2014 Saracoglu  
 D709,216 S \* 7/2014 Futschik ..... D26/28  
 D717,211 S 11/2014 Stephenson  
 D717,212 S 11/2014 Thurner et al.  
 D724,495 S 3/2015 Majdandzic  
 D734,212 S 7/2015 Stephenson  
 D734,213 S 7/2015 Stephenson  
 D738,010 S \* 9/2015 Futschik ..... D26/28  
 D741,753 S 10/2015 Perini  
 D745,439 S 12/2015 Manzoni  
 D745,986 S \* 12/2015 Gorsten Schuenemann .. D26/28  
 D753,548 S 4/2016 Gilles  
 D755,674 S 5/2016 Perini  
 D756,847 S 5/2016 Nicoghosian et al.  
 D767,446 S 9/2016 Stephenson  
 D770,647 S \* 11/2016 Bieling ..... D26/28  
 D780,063 S 2/2017 Stephenson  
 D781,747 S 3/2017 Stephenson  
 D793,909 S 8/2017 Jeung et al.  
 D801,227 S 10/2017 Stephenson  
 D804,355 S 12/2017 Stephenson  
 D837,426 S \* 1/2019 Patel ..... D26/28  
 D838,391 S \* 1/2019 McMahan ..... D26/28

FOREIGN PATENT DOCUMENTS

WO 000216650-0001 4/2005  
 WO 000681218-0002 3/2007

Certificate of Registration for European Community design, CTM No. 000346226-0001, registered May 20, 2005, 5 pgs.  
 Certificate of Registration for European Community design, CTM No. 001608936-0001, registered Aug. 9, 2009, 5 pgs.  
 Certificate of Registration for European Community design, CTM No. 002067058-0001, registered Jul. 2, 2012, 5 pgs.  
 Johnson, Erik. "2014 McLaren P1 : \$1.15M, F1-Style Tech, and Limited to 375". Car and Driver Website Mar. 11, 2014 [online]. [retrieved on May 30, 2014]. Retrieved from the Internet: <URL: <http://www.caranddriver.com/news/2014-mclaren-p1-official-photos-and-info-news>>.  
 Barari, Arman. Renderings: McLaren MP4-12C Convertible. Website [online]. <http://www.motorward.com>, Oct. 15, 2009 [retrieved on Aug. 29, 2013]. Retrieved from the Internet: <URL: <http://www.motorward.com/2009/10/renderings-mclaren-mp4-12c-convertible/>&-gt;.  
 Kurczewski, Nick. 2012 McLaren MP4-12C Convertible. McLaren drop-top will exceed 200mph. Website [online]. <http://www.roadandtrack.com>, Jun. 15, 2011 [retrieved on Aug. 29, 2013]. Retrieved from the Internet: <URL:<http://www.roadandtrack.com/go/first-looks/2012-mclaren-mp4-12c-convertible>>.  
 Sherman, Don. 2012 McLaren MP4-12C. A Horse With No Name: We finally get behind the wheel of Ferrari's worst nightmare and find its surprisingly pleasant. Website [online]. <http://www.caranddriver.com>, Feb. 14, 2011 [retrieved on Aug. 29, 2013]. Retrieved from the Internet: <URL: <http://www.caranddriver.com/reviews/2012-mclaren-mp4-12c-first-drive-rev>.  
 Joseph, Noah. Along Came a Spyder: McLaren MP4-12C production plans include retractable hardtop. Website [online]. <http://www.autoblog.com>, Oct. 7, 2009 [retrieved on Aug. 29, 2013]. Retrieved from the Internet: <URL:<http://www.autoblog.com/2009/10/07/along-came-a-spyder-mclaren-mp4-12c-production-plans-include-re/>>.  
 "McLaren Formula 1 DNA Meets the Thrill of Open Top Driving in the New 12C Spider: McLaren Automotive Media Centre", released on Jul. 3, 2012, <http://www.media.mclarenautomotive.com/release/141/>.  
 "McLaren P1 Aims for Pole Position with Global Debut in Paris", released on Sep. 27, 2012, <http://www.media.mclarenautomotive.com/release/156/>.  
 U.S. Appl. No. 29/440,834—Office Action dated Sep. 27, 2013, 14 pages.  
 U.S. Appl. No. 29/440,834—Response to Office Action dated Sep. 27, 2013 filed Jan. 17, 2014, 8 pages.  
 U.S. Appl. No. 29/440,834—Final Office Action dated Apr. 29, 2014, 9 pages.  
 U.S. Appl. No. 29/450,475—Office Action dated Jun. 16, 2014, 13 pages.  
 U.S. Appl. No. 29/450,475—Response to Office Action dated Jun. 16, 2014 filed Oct. 3, 2014, 14 pages.  
 U.S. Appl. No. 29/450,475—Final Office Action dated Feb. 10, 2015, 9 pages.  
 U.S. Appl. No. 29/530,730—Office Action dated Sep. 14, 2016, 8 pages.  
 U.S. Appl. No. 29/565,627, filed May 23, 2016, 7 pages.  
 U.S. Appl. No. 29/527,356—Notice of Allowance dated Nov. 4, 2016, 7 pages.  
 U.S. Appl. No. 29/532,362—Notice of Allowance dated Nov. 4, 2016, 12 pages.  
 U.S. Appl. No. 29/530,730—Final Office Action dated Feb. 8, 2017, 16 pages.  
 U.S. Appl. No. 29/357,079—Notice of Allowance dated Jul. 8, 2010, 7 pages.  
 U.S. Appl. No. 29/357,079—Notice of Allowance dated Oct. 12, 2010, 10 pages.  
 U.S. Appl. No. 29/440,834—Response to Final Office Action dated Apr. 29, 2014 filed Jul. 11, 2014, 23 pages.  
 U.S. Appl. No. 29/440,834—Notice of Allowance dated Aug. 15, 2014, 14 pages.  
 U.S. Appl. No. 29/530,730—Response to Office Action dated Sep. 14, 2016 filed Dec. 13, 2016, 6 pages.

(56)

**References Cited**

OTHER PUBLICATIONS

U.S. Appl. No. 29/485,634—Notice of Allowance dated Mar. 31, 2015, 10 pages.  
U.S. Appl. No. 29/485,646—Notice of Allowance dated Mar. 31, 2015, 10 pages.  
U.S. Appl. No. 29/527,271—Notice of Allowance dated May 26, 2016, 12 pages.  
U.S. Appl. No. 29/527,271—Notice of Allowance (Corrected) dated Jun. 29, 2016, 4 pages.  
U.S. Appl. No. 29/527,356—Notice of Allowance dated Jul. 14, 2016, 12 pages.  
U.S. Appl. No. 29/527,357—Notice of Allowance dated Jul. 15, 2016, 12 pages.  
U.S. Appl. No. 29/532,362—Notice of Allowance dated Sep. 1, 2016, 10 pages.  
U.S. Appl. No. 29/532,362—Notice of Allowance dated Feb. 2, 2017, 4 pages.  
U.S. Appl. No. 29/357,079, filed Mar. 5, 2010, 10 pages.  
U.S. Appl. No. 29/440,834, filed Dec. 27, 2012, 7 pages.  
U.S. Appl. No. 29/440,834, filed Mar. 18, 2013, 9 pages.

U.S. Appl. No. 29/450,475, filed Mar. 18, 2013, 9 pages.  
U.S. Appl. No. 29/530,730, filed Jun. 18, 2015, 12 pages.  
U.S. Appl. No. 29/485,634, filed Mar. 20, 2014, 3 pages.  
U.S. Appl. No. 29/485,646, filed Mar. 20, 2014, 3 pages.  
U.S. Appl. No. 29/527,271, filed May 18, 2015, 9 pages.  
U.S. Appl. No. 29/527,356, filed May 18, 2015, 8 pages.  
U.S. Appl. No. 29/527,357, filed May 18, 2015, 8 pages.  
U.S. Appl. No. 29/532,362—Notice of Allowance dated Jul. 6, 2015, 8 pages.  
U.S. Appl. No. 29/594,630, filed Feb. 21, 2017, 7 pages.  
U.S. Appl. No. 29/594,821, filed Feb. 22, 2017, 11 pages.  
U.S. Appl. No. 29/596,450, filed Mar. 8, 2017, 8 pages.  
Ferrari F430 Design Application 000216650-0001.  
K-1 Attack Roadster Design Application 681218-0002.  
<http://www.k-1attack.com/en/sucasna-modelova-rada.k1>.  
U.S. Appl. No. 29/565,627—Notice of Allowance dated Aug. 2, 2017, 19 pages.  
U.S. Appl. No. 29/594,630—Notice of Allowance (corrected) dated Jun. 21, 2018, 6 pages.  
U.S. Appl. No. 29/596,450—Notice of Allowance dated May 17, 2019, 26 pages.

\* cited by examiner



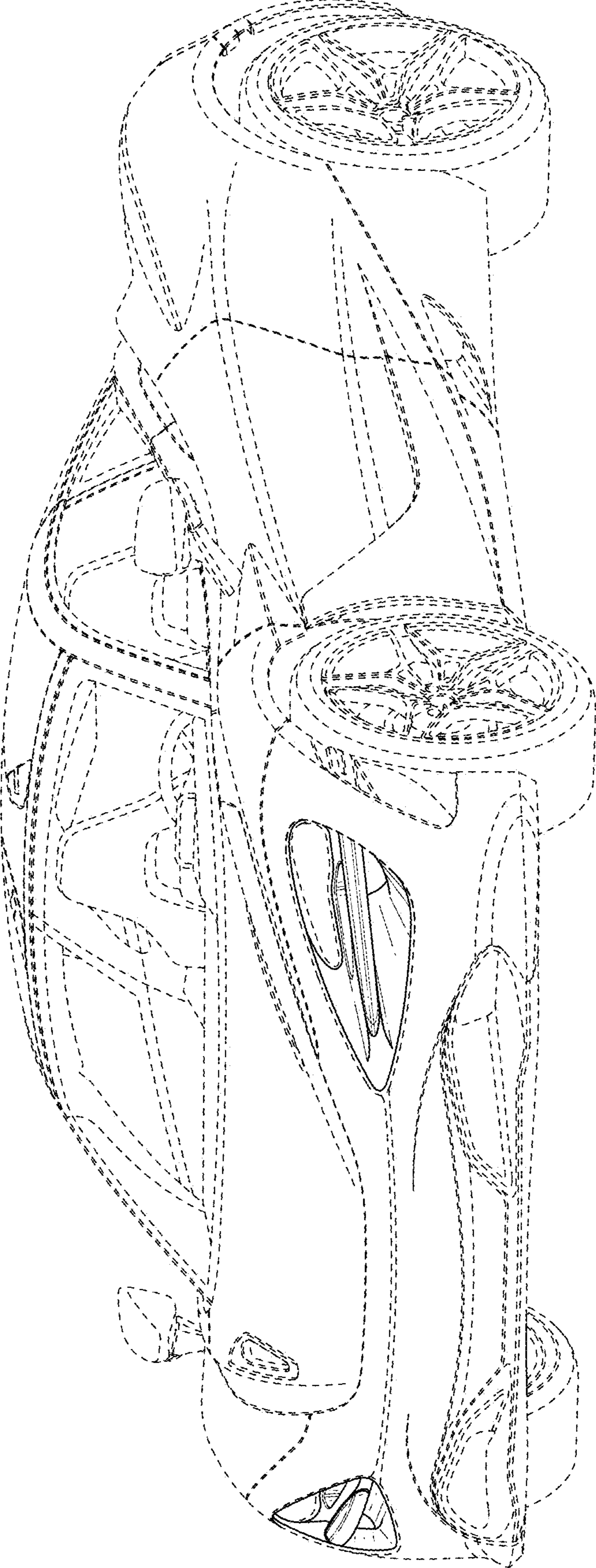

FIG 1

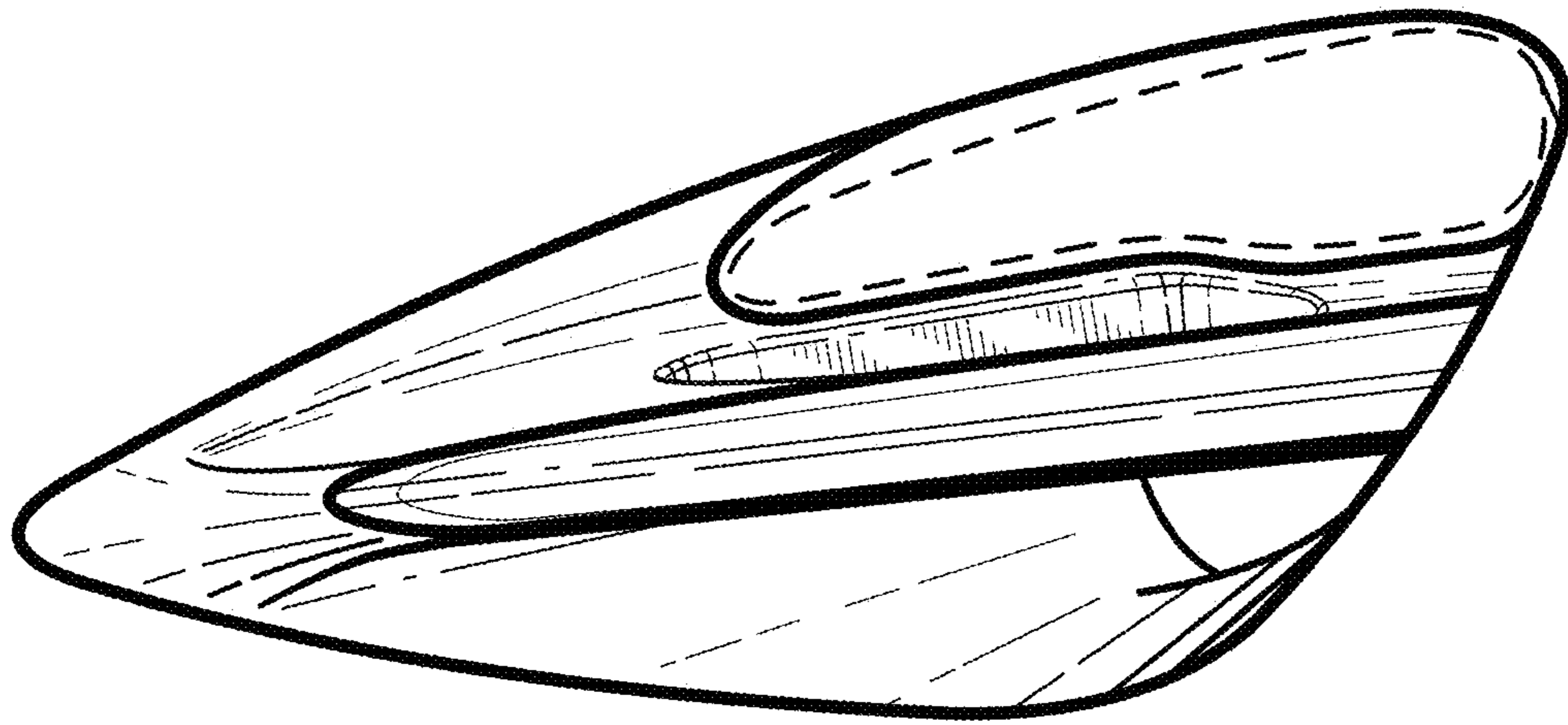

FIG 2

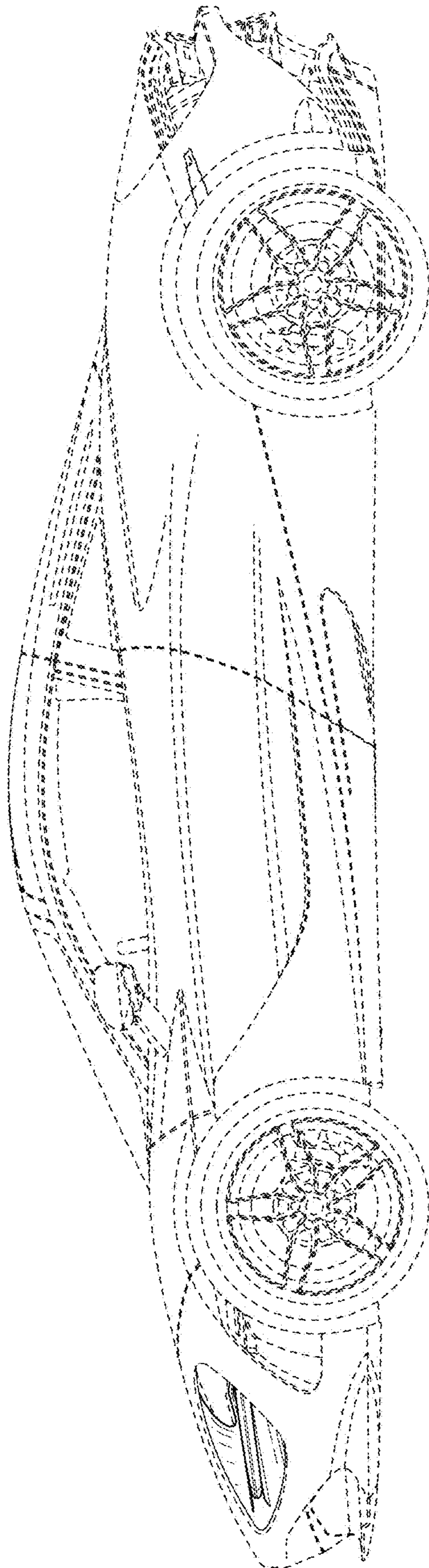

FIG 3

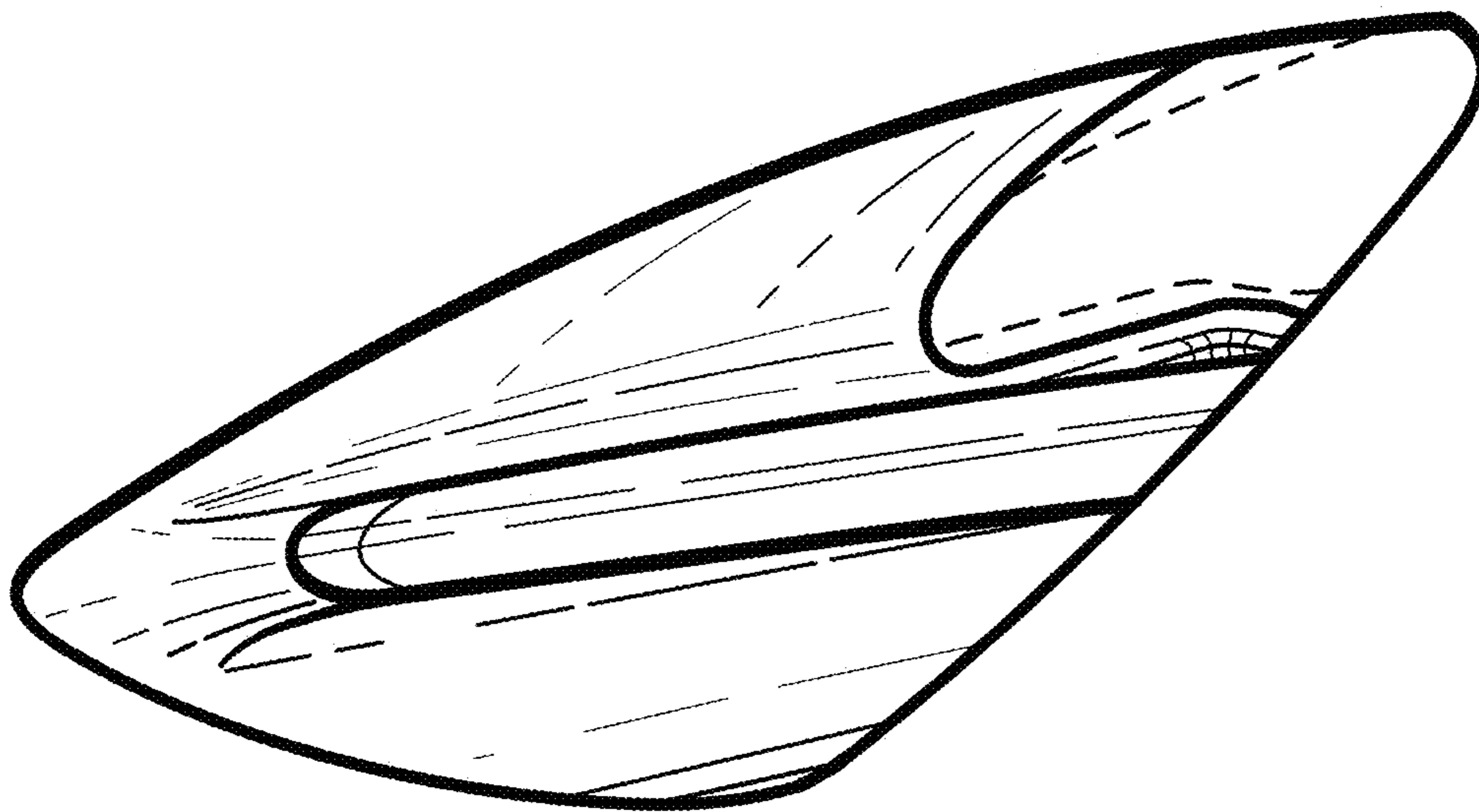

FIG 4



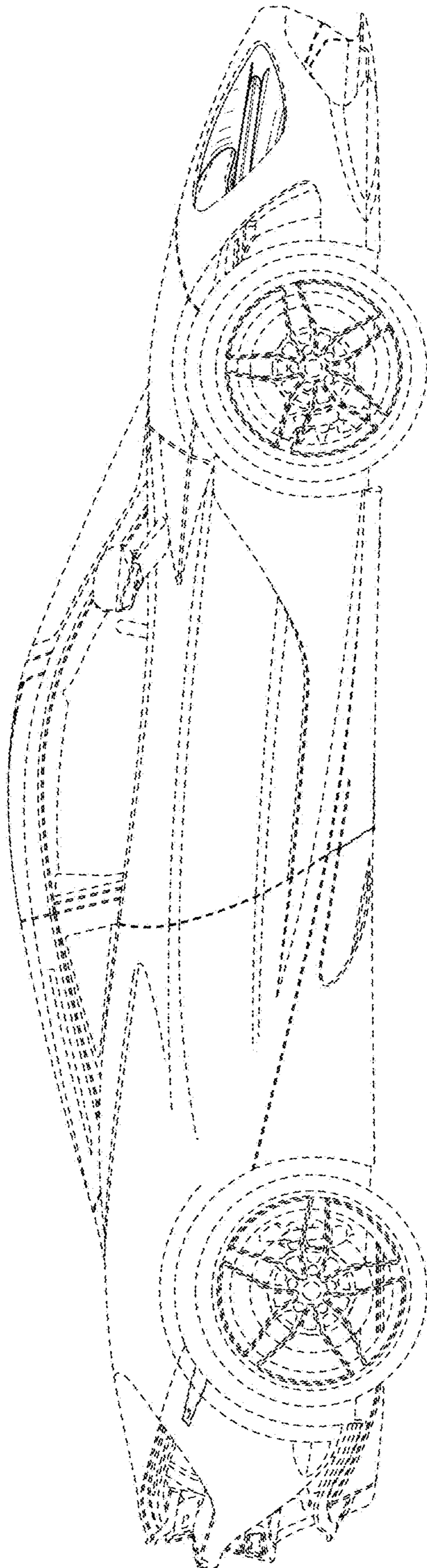

FIG 5



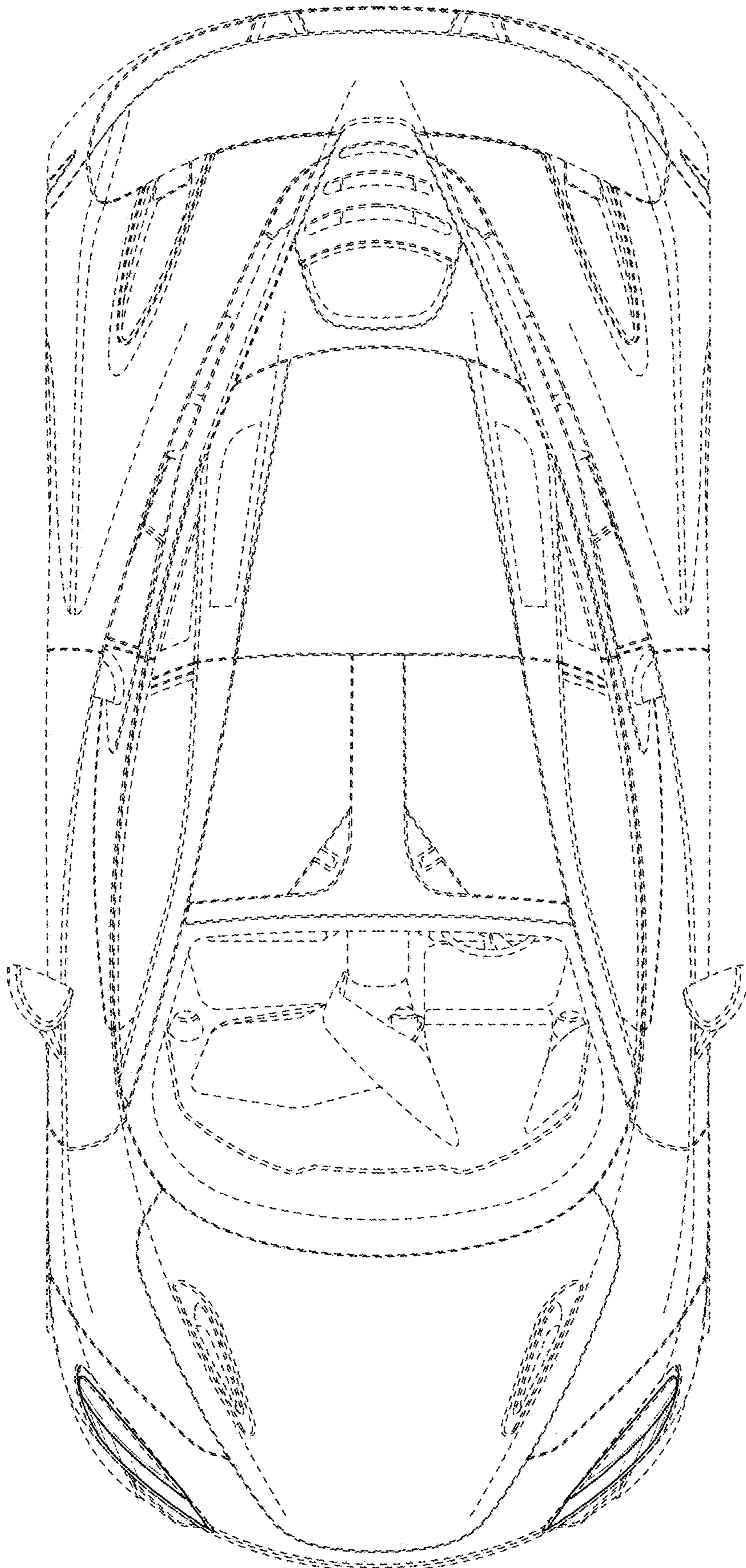
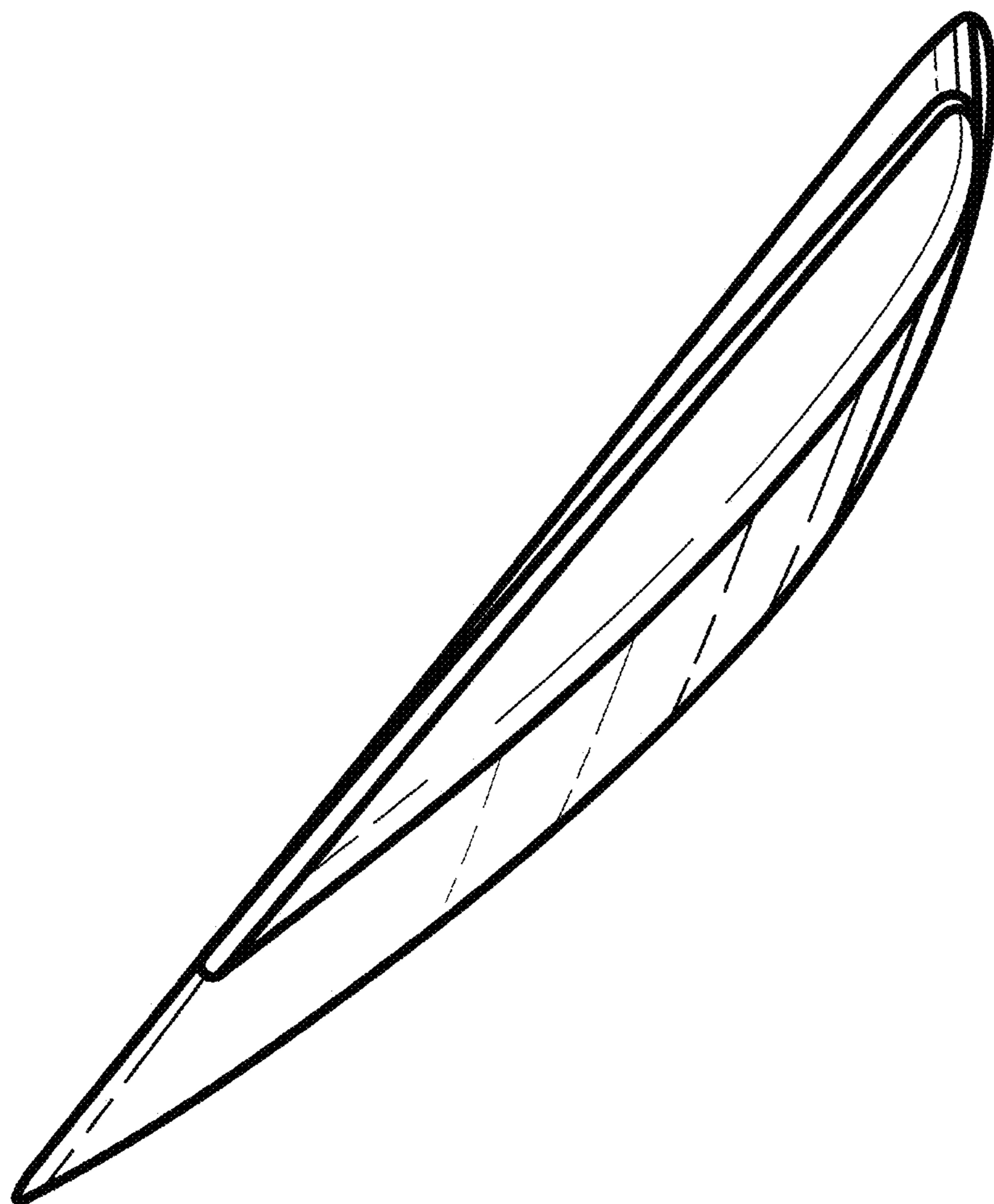
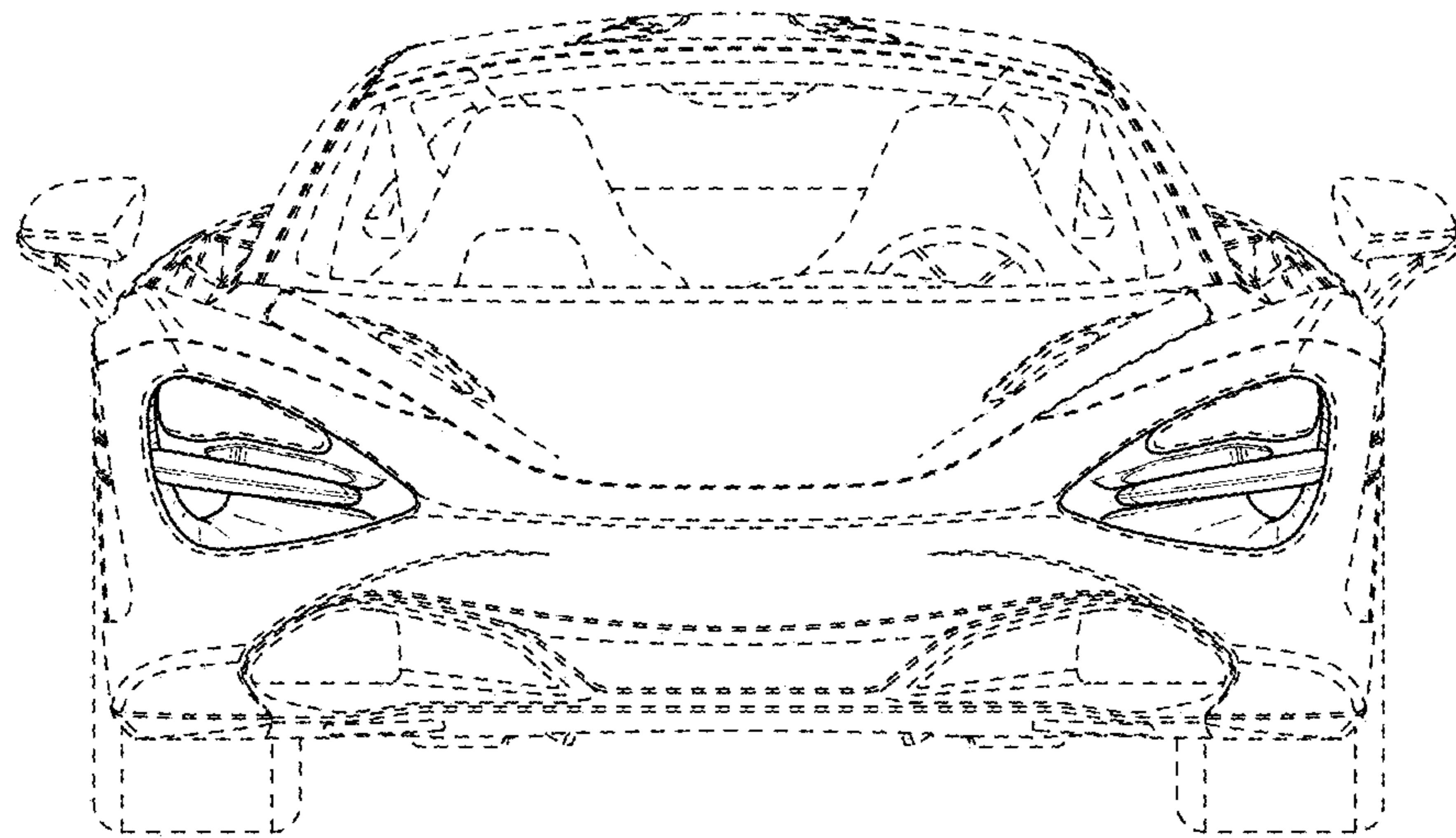

FIG 6

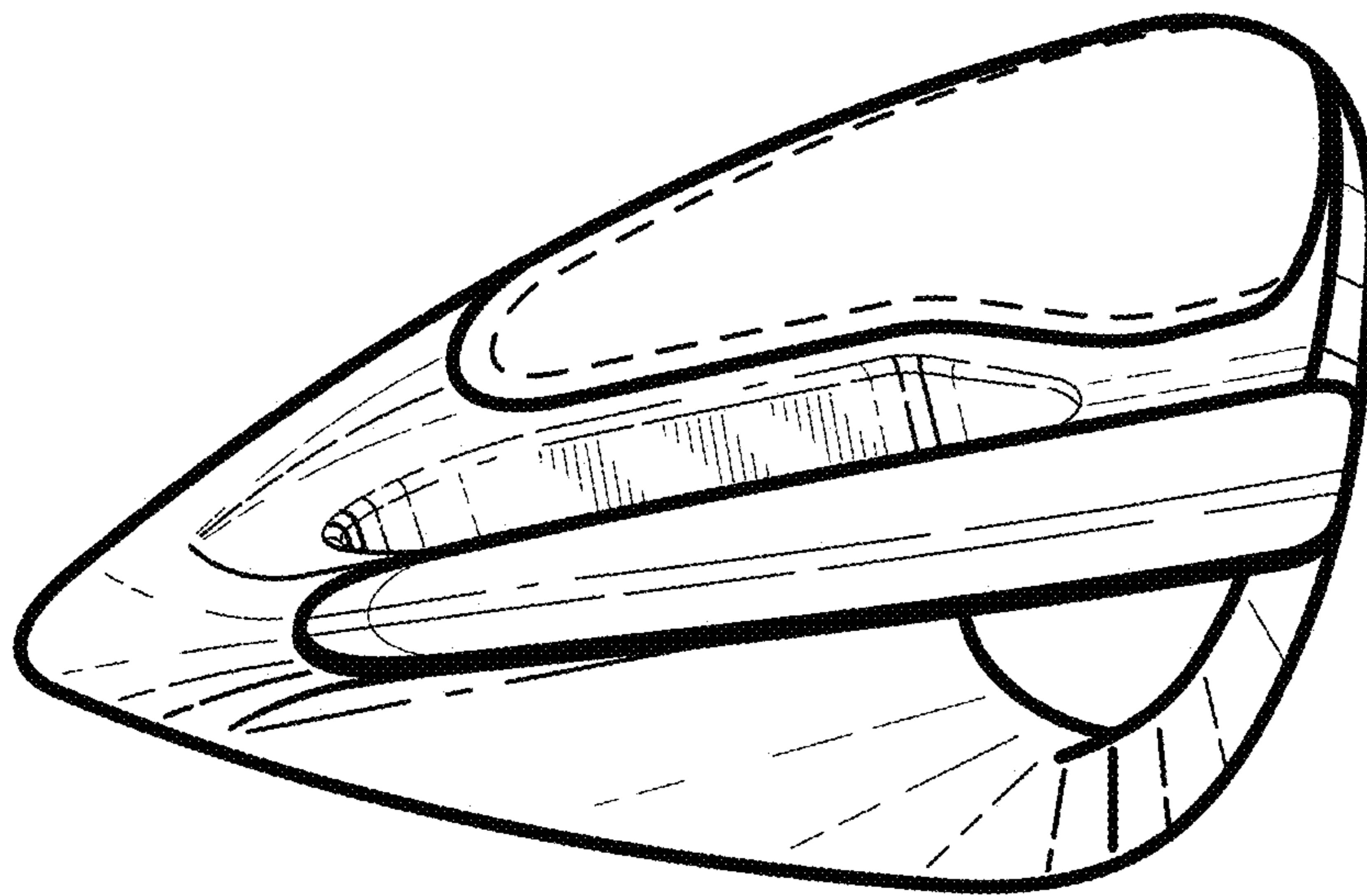

*FIG 7*



**FIG 8**





*FIG 9*