



US00D884895S

(12) **United States Design Patent** (10) **Patent No.:** **US D884,895 S**
McCormack et al. (45) **Date of Patent:** **** May 19, 2020**

- (54) **CERVICAL CAGE**
- (71) Applicant: **PROVIDENCE MEDICAL TECHNOLOGY, INC.**, Pleasanton, CA (US)
- (72) Inventors: **Bruce M. McCormack**, San Francisco, CA (US); **Edward Liou**, Pleasanton, CA (US); **Jeffrey D. Smith**, Clayton, CA (US); **Scott Schneider**, San Jose, CA (US)
- (73) Assignee: **Providence Medical Technology, Inc.**, Pleasanton, CA (US)
- (**) Term: **15 Years**
- (21) Appl. No.: **29/680,169**
- (22) Filed: **Feb. 14, 2019**

4,530,355 A	7/1985	Griggs
4,604,995 A	8/1986	Stephens et al.
4,772,287 A	9/1988	Ray et al.
4,877,020 A	10/1989	Vich
4,878,915 A	11/1989	Brantigan
5,015,247 A	5/1991	Michelson
5,026,373 A	6/1991	Ray et al.
5,100,405 A	3/1992	McLaren
5,135,528 A	8/1992	Winston
5,236,460 A	8/1993	Barber
5,484,437 A	1/1996	Michelson
5,489,307 A	2/1996	Kuslich et al.
5,505,732 A	4/1996	Michelson
5,527,312 A	6/1996	Ray
5,549,679 A	8/1996	Kuslich et al.
5,554,191 A	9/1996	Lahille et al.
5,571,191 A	11/1996	Fitz
5,584,832 A	12/1996	Schlapfer et al.
5,593,409 A	1/1997	Michelson
5,632,747 A	5/1997	Scarborough et al.
5,649,945 A	7/1997	Ray et al.
5,653,763 A	8/1997	Errico et al.
5,665,122 A	9/1997	Kambin
5,674,295 A	10/1997	Ray et al.
5,720,748 A	2/1998	Kuslich et al.
5,741,253 A	4/1998	Michelson
5,772,661 A	6/1998	Michelson
5,792,044 A	8/1998	Foley et al.
5,797,909 A	8/1998	Michelson
5,836,948 A	11/1998	Zucherman et al.
5,879,353 A	3/1999	Terry
5,885,299 A	3/1999	Winslow et al.
5,891,147 A	4/1999	Moskovitz
5,895,426 A	4/1999	Scarborough et al.
5,899,908 A	5/1999	Kuslich et al.
5,928,238 A	7/1999	Scarborough et al.
5,953,820 A	9/1999	Vasudeva
5,961,522 A	10/1999	Mehdizadeh
5,976,146 A	11/1999	Ogawa et al.
6,008,433 A	12/1999	Stone
6,033,405 A	3/2000	Winslow et al.
6,045,580 A	4/2000	Scarborough et al.
6,063,088 A	5/2000	Winslow
RE36,758 E	6/2000	Fitz
6,080,155 A	6/2000	Michelson
6,090,143 A	7/2000	Meriwether et al.
6,096,038 A	8/2000	Michelson
6,099,531 A	8/2000	Bonutti
6,102,950 A	8/2000	Vaccaro
6,113,602 A	9/2000	Sand
6,149,650 A	11/2000	Michelson
RE37,005 E	12/2000	Michelson et al.
6,159,245 A	12/2000	Meriwether et al.

Related U.S. Application Data

- (62) Division of application No. 29/542,371, filed on Oct. 13, 2015, now Pat. No. Des. 841,165.
- (51) **LOC (12) Cl.** **24-03**
- (52) **U.S. Cl.**
USPC **D24/155**
- (58) **Field of Classification Search**
USPC D24/155
CPC A61F 2/4611; A61F 2/442; A61F 2/447;
A61F 2220/0025; A61F 2310/00023;
A61F 2310/00017; A61F 2002/4475;
A61F 2002/30841; A61F 2002/2835;
A61F 2002/30904; A61F 2002/30785;
A61F 2002/443; A61F 2002/30578
See application file for complete search history.

(56) **References Cited**

U.S. PATENT DOCUMENTS

1,934,962 A	11/1933	Barry
2,708,376 A	5/1955	Booth
2,984,241 A	5/1961	Carlson
4,479,491 A	10/1984	Martin

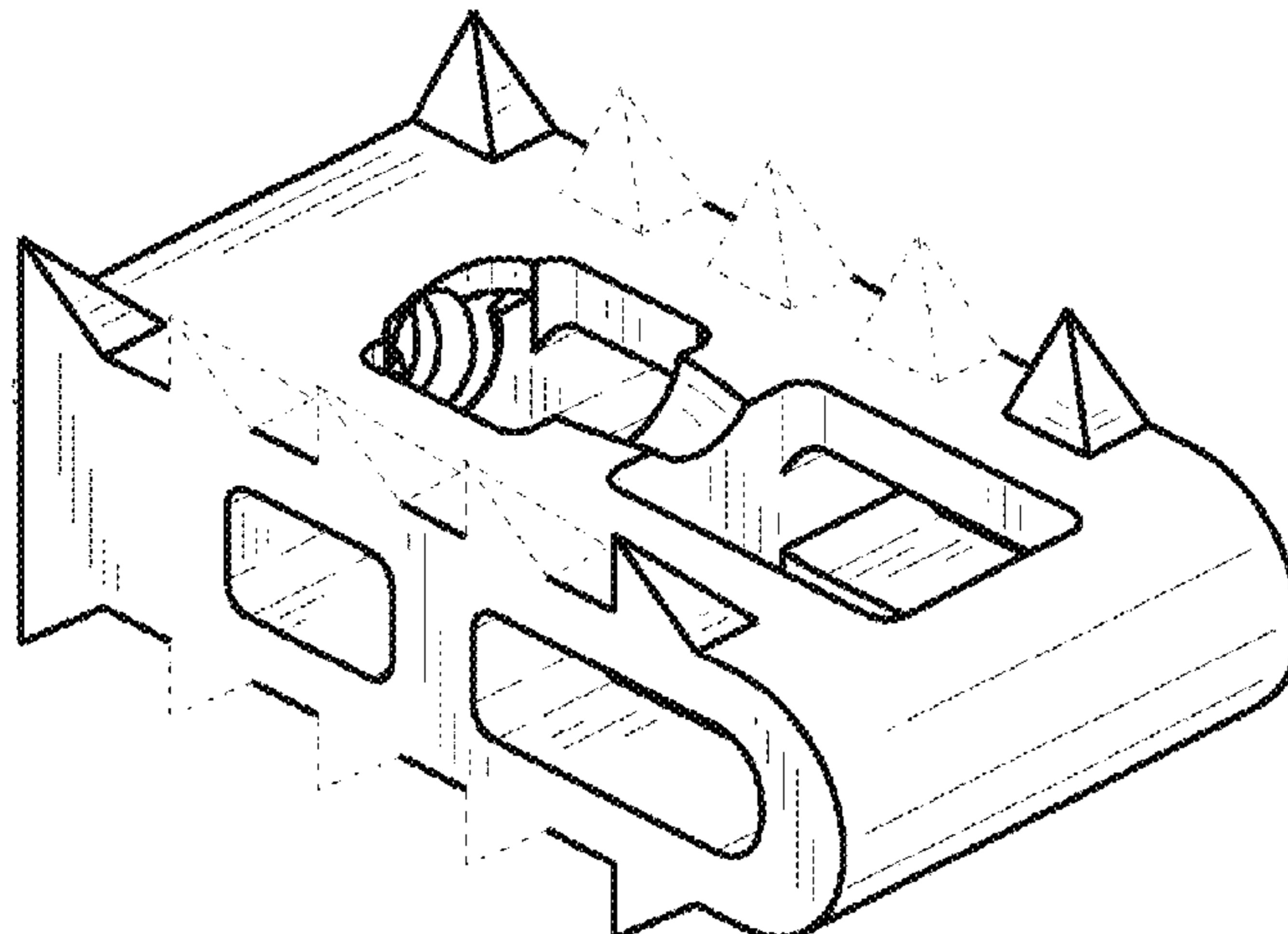

US D884,895 S

Page 2

6,176,882	B1	1/2001	Biedermann et al.	6,974,478	B2	12/2005	Reiley et al.
6,179,873	B1	1/2001	Zientek	6,979,333	B2	12/2005	Hammerslag
6,190,388	B1	2/2001	Michelson et al.	6,986,772	B2	1/2006	Michelson
6,190,414	B1	2/2001	Young et al.	7,001,385	B2	2/2006	Bonutti
6,193,757	B1	2/2001	Foley et al.	7,008,453	B1	3/2006	Michelson
6,210,412	B1	4/2001	Michelson	7,033,362	B2	4/2006	McGahan et al.
RE37,161	E	5/2001	Michelson et al.	7,033,392	B2	4/2006	Schmiel et al.
6,224,595	B1	5/2001	Michelson	7,033,394	B2	4/2006	Michelson
6,224,607	B1	5/2001	Michelson	7,066,961	B2	6/2006	Michelson
6,224,630	B1	5/2001	Bao et al.	D524,443	S	7/2006	Blain
6,245,108	B1	6/2001	Biscup	7,083,623	B2	8/2006	Michelson
6,248,110	B1	6/2001	Reiley et al.	7,090,698	B2	8/2006	Fallin et al.
D444,878	S	7/2001	Walter	7,096,972	B2	8/2006	Orozco, Jr.
D445,188	S	7/2001	Walter	7,101,398	B2	9/2006	Dooris et al.
6,264,656	B1	7/2001	Michelson	7,115,128	B2	10/2006	Michelson
6,267,763	B1	7/2001	Castro	7,118,598	B2	10/2006	Michelson
6,270,498	B1	8/2001	Michelson	7,128,760	B2	10/2006	Michelson
6,283,966	B1	9/2001	Boufburg	7,156,877	B2	1/2007	Lotz et al.
6,315,795	B1	11/2001	Scarborough et al.	7,166,110	B2	1/2007	Yundt
6,325,827	B1	12/2001	Lin	7,175,023	B2	2/2007	Martin
6,371,984	B1	4/2002	Van Dyke et al.	7,179,263	B2	2/2007	Zdeblick et al.
6,371,988	B1	4/2002	Pafford et al.	7,207,991	B2	4/2007	Michelson
6,402,784	B1	6/2002	Wardlaw	D541,940	S	5/2007	Blain
6,423,063	B1	7/2002	Bonutti	7,220,280	B2	5/2007	Kast et al.
6,423,083	B2	7/2002	Reiley et al.	7,261,739	B2	8/2007	Ralph et al.
6,425,919	B1	7/2002	Lambrecht	7,264,622	B2	9/2007	Michelson
6,436,098	B1	8/2002	Michelson	7,273,498	B2	9/2007	Bianchi et al.
6,436,142	B1	8/2002	Paes et al.	7,288,093	B2	10/2007	Michelson
6,443,988	B2	9/2002	Felt et al.	7,291,149	B1	11/2007	Michelson
6,451,023	B1	9/2002	Salazar et al.	7,300,440	B2	11/2007	Zdeblick et al.
6,454,807	B1	9/2002	Jackson	7,326,211	B2	2/2008	Padget et al.
6,478,796	B2	11/2002	Zucherman et al.	7,326,214	B2	2/2008	Michelson
6,500,206	B1	12/2002	Bryan	7,371,238	B2	5/2008	Soboleski et al.
6,514,256	B2	2/2003	Zucherman et al.	7,399,303	B2	7/2008	Michelson
6,530,955	B2	3/2003	Boyle et al.	7,410,501	B2	8/2008	Michelson
6,558,390	B2	5/2003	Cragg	7,431,722	B1	10/2008	Michelson
6,565,574	B2	5/2003	Michelson	7,445,636	B2	11/2008	Michelson
6,565,605	B2	5/2003	Fallin et al.	7,452,359	B1	11/2008	Michelson
6,569,186	B1	5/2003	Winters et al.	7,452,369	B2	11/2008	Barry
6,575,919	B1	6/2003	Reiley et al.	7,465,304	B1	12/2008	Haufe et al.
6,575,979	B1	6/2003	Cragg	7,476,226	B2	1/2009	Weikel et al.
6,579,319	B2	6/2003	Goble et al.	7,476,251	B2	1/2009	Zucherman et al.
6,582,432	B1	6/2003	Michelson	7,479,160	B2	1/2009	Branch et al.
6,607,530	B1	8/2003	Carl et al.	7,491,205	B1	2/2009	Michelson
6,610,091	B1	8/2003	Reiley	7,491,240	B1	2/2009	Carver et al.
6,626,905	B1	9/2003	Schmiel et al.	7,500,992	B2	3/2009	Li
6,632,235	B2	10/2003	Weikel et al.	7,517,358	B2	4/2009	Peterson
6,635,060	B2	10/2003	Hanson et al.	7,524,333	B2	4/2009	Lambrecht et al.
6,641,582	B1	11/2003	Hanson et al.	7,569,054	B2	8/2009	Michelson
6,648,893	B2	11/2003	Dudasik	7,569,057	B2	8/2009	Liu et al.
6,652,584	B2	11/2003	Michelson	7,580,743	B2	8/2009	Bourlion et al.
6,663,647	B2	12/2003	Reiley et al.	7,591,851	B2	9/2009	Winslow et al.
6,666,866	B2	12/2003	Martz et al.	7,601,170	B2	10/2009	Winslow et al.
6,679,886	B2	1/2004	Weikel et al.	7,608,077	B2	10/2009	Cragg et al.
6,682,535	B2	1/2004	Hoogland	7,608,107	B2	10/2009	Michelson
6,685,742	B1	2/2004	Jackson	7,615,079	B2	11/2009	Flickinger et al.
6,709,458	B2	3/2004	Michelson	7,618,451	B2	11/2009	Berez et al.
6,712,853	B2	3/2004	Kuslich	7,632,291	B2	12/2009	Stephens et al.
6,719,773	B1	4/2004	Boucher et al.	7,641,664	B2	1/2010	Pagano
6,723,095	B2	4/2004	Hammerslag	7,648,509	B2	1/2010	Stark
6,733,534	B2	5/2004	Sherman	7,648,523	B2	1/2010	Mirkovic et al.
6,740,093	B2	5/2004	Hochschuler et al.	7,655,027	B2	2/2010	Michelson
6,751,875	B2	6/2004	Jones	7,655,043	B2	2/2010	Peterman et al.
6,770,074	B2	8/2004	Michelson	7,662,173	B2	2/2010	Cragg et al.
6,793,679	B2	9/2004	Michelson	D611,147	S	3/2010	Hanson et al.
6,805,715	B2	10/2004	Reuter et al.	7,682,378	B2	3/2010	Truckai et al.
6,808,537	B2	10/2004	Michelson	7,686,805	B2	3/2010	Michelson
6,823,871	B2	11/2004	Schmieding	7,686,807	B2	3/2010	Padget et al.
6,840,941	B2	1/2005	Rogers et al.	7,699,878	B2	4/2010	Pavlov et al.
6,851,430	B2	2/2005	Tsou	D615,653	S	5/2010	Horton
6,875,213	B2	4/2005	Michelson	7,708,761	B2	5/2010	Petersen
6,899,719	B2	5/2005	Reiley et al.	7,722,619	B2	5/2010	Michelson
6,921,403	B2	7/2005	Cragg et al.	D619,719	S	7/2010	Pannu
6,923,813	B2	8/2005	Phillips et al.	7,763,024	B2	7/2010	Bertagnoli et al.
6,958,077	B2	10/2005	Suddaby	7,763,050	B2	7/2010	Winslow et al.
6,962,606	B2	11/2005	Michelson	7,776,090	B2	8/2010	Winslow et al.
6,964,686	B2	11/2005	Gordon	D623,748	S	9/2010	Horton et al.
6,966,930	B2	11/2005	Arnin et al.	D623,749	S	9/2010	Horton et al.
6,972,035	B2	12/2005	Michelson	7,789,898	B2	9/2010	Peterman

US D884,895 S

D627,468 S	11/2010	Richter et al.	9,271,765 B2	3/2016	Blain
7,824,431 B2	11/2010	McCormack	9,333,086 B2	5/2016	McCormack et al.
7,837,713 B2	11/2010	Peterson	9,381,049 B2 *	7/2016	McCormack A61F 2/4405
7,846,183 B2	12/2010	Blain	9,427,264 B2	8/2016	Kleiner et al.
7,846,184 B2	12/2010	Sasso et al.	9,504,583 B2	11/2016	Blain
7,850,733 B2	12/2010	Baynham et al.	9,622,791 B2	4/2017	Mccormack et al.
7,862,589 B2	1/2011	Thramann	9,622,873 B2	4/2017	Mccormack
7,867,277 B1	1/2011	Tohmeh	9,622,874 B2	4/2017	Mccormack et al.
D631,967 S	2/2011	Horton	9,629,665 B2	4/2017	Mccormack et al.
7,879,098 B1	2/2011	Simmons, Jr.	9,717,403 B2	8/2017	Kleiner et al.
7,887,565 B2	2/2011	Michelson	10,039,649 B2	8/2018	Mccormack et al.
7,892,261 B2	2/2011	Bonutti	10,149,673 B2	12/2018	Mccormack et al.
7,892,286 B2	2/2011	Michelson	10,172,721 B2	1/2019	Mccormack et al.
7,896,803 B2	3/2011	Schara et al.	D841,165 S	2/2019	Mccormack et al.
7,896,903 B2	3/2011	Link	10,201,375 B2	2/2019	Mccormack et al.
7,901,439 B2	3/2011	Horton	10,219,910 B2	3/2019	Mccormack
7,914,530 B2	3/2011	Michelson	10,226,285 B2	3/2019	Mccormack et al.
7,918,891 B1	4/2011	Curran et al.	10,238,501 B2	3/2019	Mccormack et al.
7,922,729 B2	4/2011	Michelson	2001/0004710 A1	6/2001	Felt et al.
7,922,766 B2	4/2011	Grob et al.	2001/0047208 A1	11/2001	Michelson
7,935,136 B2	5/2011	Alamin et al.	2002/0026195 A1	2/2002	Layne et al.
7,938,857 B2	5/2011	Krueger et al.	2002/0068941 A1	6/2002	Hanson et al.
7,942,903 B2	5/2011	Moskowitz et al.	2002/0107519 A1	8/2002	Dixon et al.
7,988,712 B2	8/2011	Hale et al.	2002/0143343 A1	10/2002	Castro
7,988,714 B2	8/2011	Puekert et al.	2002/0147496 A1	10/2002	Belef et al.
7,998,174 B2	8/2011	Malandain et al.	2002/0147497 A1	10/2002	Belef et al.
8,007,534 B2	8/2011	Michelson	2002/0165612 A1	11/2002	Gerber et al.
8,029,540 B2	10/2011	Winslow et al.	2002/0169471 A1	11/2002	Ferdinand
8,043,334 B2	10/2011	Fisher et al.	2003/0023312 A1	1/2003	Thalgott
8,052,728 B2	11/2011	Hestad	2003/0028251 A1	2/2003	Mathews
8,062,303 B2	11/2011	Berry et al.	2003/0032962 A1	2/2003	McGahan et al.
8,066,705 B2	11/2011	Michelson	2003/0033017 A1	2/2003	Lotz et al.
D650,481 S	12/2011	Gottlieb et al.	2003/0105526 A1	6/2003	Bryant et al.
8,097,034 B2	1/2012	Michelson	2003/0109928 A1	6/2003	Pasquet et al.
8,100,944 B2	1/2012	Laurysen et al.	2003/0139816 A1	7/2003	Michelson
D653,757 S	2/2012	Binder	2003/0144737 A1	7/2003	Sherman
8,114,158 B2	2/2012	Carl et al.	2003/0158553 A1	8/2003	Michelson
8,118,838 B2	2/2012	Winslow et al.	2003/0225416 A1	12/2003	Bonvallet et al.
8,128,660 B2	3/2012	Mitchel et al.	2004/0059337 A1	3/2004	Hanson et al.
8,133,261 B2	3/2012	Fisher et al.	2004/0073217 A1	4/2004	Michelson
8,142,503 B2	3/2012	Malone	2004/0087948 A1	5/2004	Suddaby
8,147,553 B2	4/2012	Vresilovic et al.	2004/0087956 A1	5/2004	Weikel et al.
8,162,981 B2	4/2012	Vestgaarden	2004/0106999 A1	6/2004	Mathews
8,172,877 B2	5/2012	Winslow et al.	2004/0133277 A1	7/2004	Michelson
8,177,872 B2	5/2012	Nelson et al.	2004/0133280 A1	7/2004	Trieu
8,197,513 B2	6/2012	Fisher et al.	2004/0162562 A1	8/2004	Martz
8,206,418 B2	6/2012	Triplet et al.	2004/0215344 A1	10/2004	Hochshculer et al.
8,267,966 B2	9/2012	McCormack et al.	2005/0010294 A1	1/2005	Michelson
D674,900 S	1/2013	Janice et al.	2005/0015149 A1	1/2005	Michelson
8,348,979 B2	1/2013	McCormack	2005/0027358 A1	2/2005	Suddaby
8,361,152 B2	1/2013	McCormack et al.	2005/0033432 A1	2/2005	Gordon et al.
8,366,748 B2	2/2013	Kleiner	2005/0049705 A1	3/2005	Hale et al.
D677,791 S	3/2013	Danacioglu et al.	2005/0055096 A1	3/2005	Serhan et al.
8,394,107 B2	3/2013	Fanger et al.	2005/0065518 A1	3/2005	Michelson
8,394,129 B2	3/2013	Morgenstern et al.	2005/0065519 A1	3/2005	Michelson
D681,205 S	4/2013	Farris et al.	2005/0065608 A1	3/2005	Michelson
8,425,558 B2	4/2013	McCormack et al.	2005/0065609 A1	3/2005	Wardlaw
8,512,347 B2	8/2013	McCormack et al.	2005/0080422 A1	4/2005	Otte et al.
8,523,908 B2	9/2013	Malone	2005/0090829 A1	4/2005	Martz et al.
8,529,609 B2	9/2013	Helgersen et al.	2005/0090901 A1	4/2005	Studer
8,623,054 B2	1/2014	McCormack et al.	2005/0119680 A1	6/2005	Dykes
8,668,722 B2	3/2014	Pavlov et al.	2005/0124993 A1	6/2005	Chappuis
8,753,345 B2	6/2014	McCormack et al.	2005/0159650 A1	7/2005	Raymond et al.
8,753,347 B2	6/2014	McCormack et al.	2005/0159746 A1	7/2005	Grob et al.
8,764,755 B2	7/2014	Michelson	2005/0177240 A1	8/2005	Blain
8,828,062 B2	9/2014	McCormack et al.	2005/0182417 A1	8/2005	Pagano
8,834,530 B2	9/2014	McCormack	2005/0216018 A1	9/2005	Sennett
8,845,727 B2	9/2014	Gottlieb et al.	2005/0234455 A1	10/2005	Binder et al.
8,870,882 B2	10/2014	Kleiner	2005/0240188 A1	10/2005	Chow et al.
D723,690 S	3/2015	McCormack et al.	2005/0251146 A1	11/2005	Martz et al.
D723,691 S *	3/2015	McCormack D24/155	2005/0251257 A1	11/2005	Mitchell et al.
8,998,905 B2	4/2015	Marik et al.	2005/0267480 A1	12/2005	Suddaby
9,005,288 B2	4/2015	Mccormack et al.	2006/0004367 A1	1/2006	Alamin et al.
9,011,492 B2	4/2015	McCormack et al.	2006/0015184 A1	1/2006	Winterbottom et al.
D732,667 S *	6/2015	McCormack D24/155	2006/0036243 A1	2/2006	Sasso et al.
D745,156 S *	12/2015	McCormack D24/155	2006/0036247 A1	2/2006	Michelson
9,211,198 B2	12/2015	Michelson	2006/0036323 A1	2/2006	Carl et al.
9,220,608 B2	12/2015	McKay	2006/0041311 A1	2/2006	McLeer
D750,249 S	2/2016	Grimberg, Jr. et al.	2006/0058793 A1	3/2006	Michelson

US D884,895 S

2006/0058878	A1	3/2006	Michelson	2008/0255618	A1	10/2008	Fisher et al.
2006/0069442	A1	3/2006	Michelson	2008/0255622	A1	10/2008	Mickiewicz et al.
2006/0079905	A1	4/2006	Beyar et al.	2008/0255666	A1	10/2008	Fisher et al.
2006/0079962	A1	4/2006	Michelson	2008/0255667	A1	10/2008	Horton
2006/0085068	A1	4/2006	Barry	2008/0287955	A1	11/2008	Michelson
2006/0085074	A1	4/2006	Raiszadeh	2008/0306537	A1	12/2008	Culbert
2006/0095028	A1	5/2006	Bleich	2008/0312744	A1	12/2008	Vresilovic et al.
2006/0095036	A1	5/2006	Hammerslag	2009/0131986	A1	5/2009	Lee et al.
2006/0111779	A1	5/2006	Peterson	2009/0138053	A1	5/2009	Assell et al.
2006/0111780	A1	5/2006	Petersen	2009/0177205	A1	7/2009	McCormack et al.
2006/0111781	A1	5/2006	Petersen	2009/0177215	A1	7/2009	Stack et al.
2006/0142762	A1	6/2006	Michelson	2009/0177237	A1	7/2009	Zucherman et al.
2006/0149289	A1	7/2006	Winslow et al.	2009/0234397	A1	9/2009	Petersen
2006/0184172	A1	8/2006	Michelson	2009/0248076	A1	10/2009	Reynolds et al.
2006/0189991	A1	8/2006	Bickley	2009/0263461	A1	10/2009	McKay
2006/0190081	A1	8/2006	Kraus et al.	2009/0270929	A1	10/2009	Suddaby et al.
2006/0195109	A1	8/2006	McGahan et al.	2009/0275994	A1	11/2009	Phan et al.
2006/0200137	A1	9/2006	Soboleski et al.	2010/0086185	A1	4/2010	Weiss
2006/0200138	A1	9/2006	Michelson	2010/0093829	A1	4/2010	Gorman
2006/0200139	A1	9/2006	Michelson	2010/0111829	A1	5/2010	Drapeau et al.
2006/0206118	A1	9/2006	Kim et al.	2010/0114105	A1	5/2010	Butters et al.
2006/0217812	A1	9/2006	Lambrecht et al.	2010/0114318	A1	5/2010	Gittings et al.
2006/0235391	A1	10/2006	Sutterlin, III	2010/0145391	A1	6/2010	Kleiner
2006/0241597	A1	10/2006	Mitchell et al.	2010/0145459	A1	6/2010	McDonough et al.
2006/0241626	A1	10/2006	McGahan et al.	2010/0211104	A1	8/2010	Moumene et al.
2006/0241758	A1	10/2006	Peterman et al.	2011/0004247	A1	1/2011	Lechmann et al.
2006/0247632	A1	11/2006	Winslow et al.	2011/0022089	A1	1/2011	Assell et al.
2006/0247633	A1	11/2006	Winslow et al.	2011/0054613	A1	3/2011	Hansen
2006/0247650	A1	11/2006	Yerby et al.	2011/0077686	A1	3/2011	Mishra et al.
2006/0259142	A1	11/2006	Dooris et al.	2011/0082548	A1	4/2011	Assell et al.
2006/0271195	A1	11/2006	Thramann	2011/0144755	A1	6/2011	Baynham et al.
2006/0276790	A1	12/2006	Dawson et al.	2011/0184470	A1	7/2011	Gorek et al.
2006/0276801	A1	12/2006	Yerby et al.	2011/0190821	A1	8/2011	Chin et al.
2006/0276897	A1	12/2006	Winslow et al.	2011/0245930	A1	10/2011	Alley et al.
2006/0293663	A1	12/2006	Walkenhorst et al.	2011/0295327	A1	12/2011	Moskowitz et al.
2007/0016195	A1	1/2007	Winslow et al.	2011/0307061	A1	12/2011	Assell et al.
2007/0016196	A1	1/2007	Winslow et al.	2012/0010659	A1	1/2012	Angert et al.
2007/0016218	A1	1/2007	Winslow et al.	2012/0010662	A1	1/2012	O'Neil et al.
2007/0032871	A1	2/2007	Michelson	2012/0010669	A1	1/2012	O'Neil et al.
2007/0043362	A1	2/2007	Malandain et al.	2012/0065613	A1	3/2012	Pepper et al.
2007/0050031	A1	3/2007	Khosrowshahi	2012/0143334	A1	6/2012	Boyce et al.
2007/0055245	A1	3/2007	Sasso et al.	2012/0215259	A1	8/2012	Cannestra
2007/0055263	A1	3/2007	Way et al.	2012/0265250	A1	10/2012	Ali
2007/0073402	A1	3/2007	Vresilovic et al.	2012/0283776	A1	11/2012	Mishra
2007/0083265	A1	4/2007	Malone	2012/0323242	A1	12/2012	Tsuang et al.
2007/0123863	A1	5/2007	Winslow et al.	2013/0013070	A1	1/2013	McCormack et al.
2007/0123888	A1	5/2007	Bleich et al.	2013/0023889	A1	1/2013	Blain et al.
2007/0135814	A1	6/2007	Farris	2013/0110168	A1	5/2013	McCormack et al.
2007/0135921	A1	6/2007	Park	2013/0110243	A1	5/2013	Patterson et al.
2007/0149976	A1	6/2007	Hale et al.	2013/0123922	A1	5/2013	McCormack et al.
2007/0149983	A1	6/2007	Link	2013/0144389	A1	6/2013	Bonutti
2007/0150061	A1	6/2007	Trieu	2013/0226239	A1	8/2013	Altarac et al.
2007/0161991	A1	7/2007	Altarac et al.	2013/0253649	A1	9/2013	Davis
2007/0179617	A1	8/2007	Brown et al.	2013/0274763	A1	10/2013	Drapeau et al.
2007/0179619	A1	8/2007	Grob et al.	2013/0310839	A1	11/2013	McCormack et al.
2007/0225721	A1	9/2007	Thelen et al.	2013/0310943	A1	11/2013	McCormack et al.
2007/0225812	A1	9/2007	Gill	2013/0317548	A1	11/2013	Malone
2007/0244483	A9	10/2007	Winslow et al.	2013/0338720	A1	12/2013	Kleiner
2007/0276491	A1	11/2007	Ahrens	2014/0100657	A1*	4/2014	McCormack A61F 2/4405 623/17.11
2007/0282441	A1	12/2007	Stream et al.	2014/0296916	A1	10/2014	Mccormack et al.
2007/0288014	A1	12/2007	Shadduck et al.	2015/0100129	A1	4/2015	Waugh et al.
2007/0299451	A1	12/2007	Tulkis	2015/0201977	A1	7/2015	McCormack et al.
2008/0015581	A1	1/2008	Eckman	2015/0297357	A1	10/2015	McCormack et al.
2008/0021457	A1	1/2008	Anderson et al.	2015/0342648	A1	12/2015	Mccormack et al.
2008/0021464	A1	1/2008	Morin et al.	2015/0342649	A1	12/2015	Mccormack et al.
2008/0058954	A1	3/2008	Trieu	2016/0008040	A1	1/2016	Mccormack et al.
2008/0065219	A1	3/2008	Dye	2016/0242754	A1	8/2016	Mccormack et al.
2008/0097436	A1	4/2008	Culbert et al.	2016/0250035	A1	9/2016	De Villiers et al.
2008/0108996	A1	5/2008	Padget et al.	2017/0027713	A1	2/2017	Kleiner
2008/0140207	A1	6/2008	Olmos et al.	2017/0189199	A1	7/2017	Maier et al.
2008/0161810	A1	7/2008	Melkent	2017/0348027	A1	12/2017	Mccormack et al.
2008/0161929	A1	7/2008	McCormack et al.	2017/0354444	A1	12/2017	Mccormack et al.
2008/0167657	A1	7/2008	Greenhaigh	2018/0161077	A1	6/2018	Mccormack et al.
2008/0177311	A1	7/2008	Winslow et al.	2018/0303631	A1	10/2018	Phan et al.
2008/0216846	A1	9/2008	Levin	2019/0209151	A1	7/2019	Mccormack et al.
2008/0234677	A1	9/2008	Dahners et al.	2019/0239932	A1	8/2019	Mccormack et al.
2008/0234758	A1	9/2008	Fisher et al.	2019/0240041	A1	8/2019	Mccormack et al.
2008/0249571	A1	10/2008	Sasso et al.				
2008/0255564	A1	10/2008	Michelson				

FOREIGN PATENT DOCUMENTS

DE	G9304368.6	U1	5/2003
FR	2722980	A1	2/1996
WO	9641582	A1	12/1996
WO	99/49818	A1	10/1999
WO	00/35388	A1	6/2000
WO	0053126	A1	9/2000
WO	01/01895	A1	1/2001
WO	2002/038062		5/2002
WO	0234120	A2	5/2002
WO	02/076335	A2	10/2002
WO	2006058221		6/2006
WO	2006130791		12/2006
WO	2007120903	A2	10/2007
WO	2008083349		7/2008
WO	2008083349	A1	7/2008
WO	2008127978	A2	10/2008
WO	2008153732	A1	12/2008
WO	2009089367		7/2009
WO	2009148619		12/2009
WO	2010030994		3/2010
WO	2010074714		7/2010
WO	2010107692	A1	9/2010
WO	2011050140	A1	4/2011
WO	2013043584	A2	3/2013
WO	2014188280	A2	11/2014
WO	2016049784		4/2016

OTHER PUBLICATIONS

US 7,063,700 B2, 06/2006, Michelson (withdrawn)
 Atul Goel, Facetal distraction as treatment for single- and multilevel cervical spondylotic radiculopathy and myelopathy: a preliminary report, *J Neurosurg Spine*, Jun. 2011, pp. 689-696.
 Press Release, Interventional Spine, Inc., Interventional Spine, Inc. Introduces the PERPOS Fusion Facet Prep Kit, Oct. 14, 2008, 1 Page.
 Press Release, minSURG Corp., Orthopedic Development Corporation's TruFUSE Procedure Tops 1,750 Patients in First Year, Sep. 24, 2007, 1 Page.
 Press Release, Interventional Spine, Inc., FDA Grants Conditional Approval to Interventional Spine's PercuDyn System IDE Application, Jul. 1, 2008, 1 Page.
 Stein, et al., "Percutaneous Facet Joint Fusion: Preliminary Experience," *Journal of Vascular and Interventional Radiology*, Jan.-Feb. 1993, pp. 69-74, vol. 4, No. 1.

* cited by examiner

Primary Examiner — Charles D Hanson

(74) Attorney, Agent, or Firm — Dorsey & Whitney LLP

(57)

CLAIM

The ornamental design for a cervical cage, as shown and described.

DESCRIPTION

FIG. 1 shows a front perspective view of a cervical cage; FIG. 2 shows a right side view of the cervical cage of FIG. 1;
 FIG. 3 shows a left side view of the cervical cage of FIG. 1;
 FIG. 4 shows a front view of the cervical cage of FIG. 1;
 FIG. 5 shows a rear view of the cervical cage of FIG. 1;
 FIG. 6 shows a top view of the cervical cage of FIG. 1;
 FIG. 7 shows a bottom view of the cervical cage of FIG. 1;
 FIG. 8 shows a front perspective view of a cervical cage; FIG. 9 shows a right side view of the cervical cage of FIG. 8;
 FIG. 10 shows a left side view of the cervical cage of FIG. 8;
 FIG. 11 shows a front view of the cervical cage of FIG. 8;
 FIG. 12 shows a rear view of the cervical cage of FIG. 8;
 FIG. 13 shows a top view of the cervical cage of FIG. 8;
 FIG. 14 shows a bottom view of the cervical cage of FIG. 8;
 FIG. 15 shows a front perspective view of a cervical cage; FIG. 16 shows a right side view of the cervical cage of FIG. 15;
 FIG. 17 shows a left side view of the cervical cage of FIG. 15;
 FIG. 18 shows a front view of the cervical cage of FIG. 15;
 FIG. 19 shows a rear view of the cervical cage of FIG. 15;
 FIG. 20 shows a top view of the cervical cage of FIG. 15; and,
 FIG. 21 shows a bottom view of the cervical cage of FIG. 15.
 The broken lines in FIGS. 1-21 illustrate the environment and boundaries of the cervical cage and form no part of the claimed design.

1 Claim, 6 Drawing Sheets

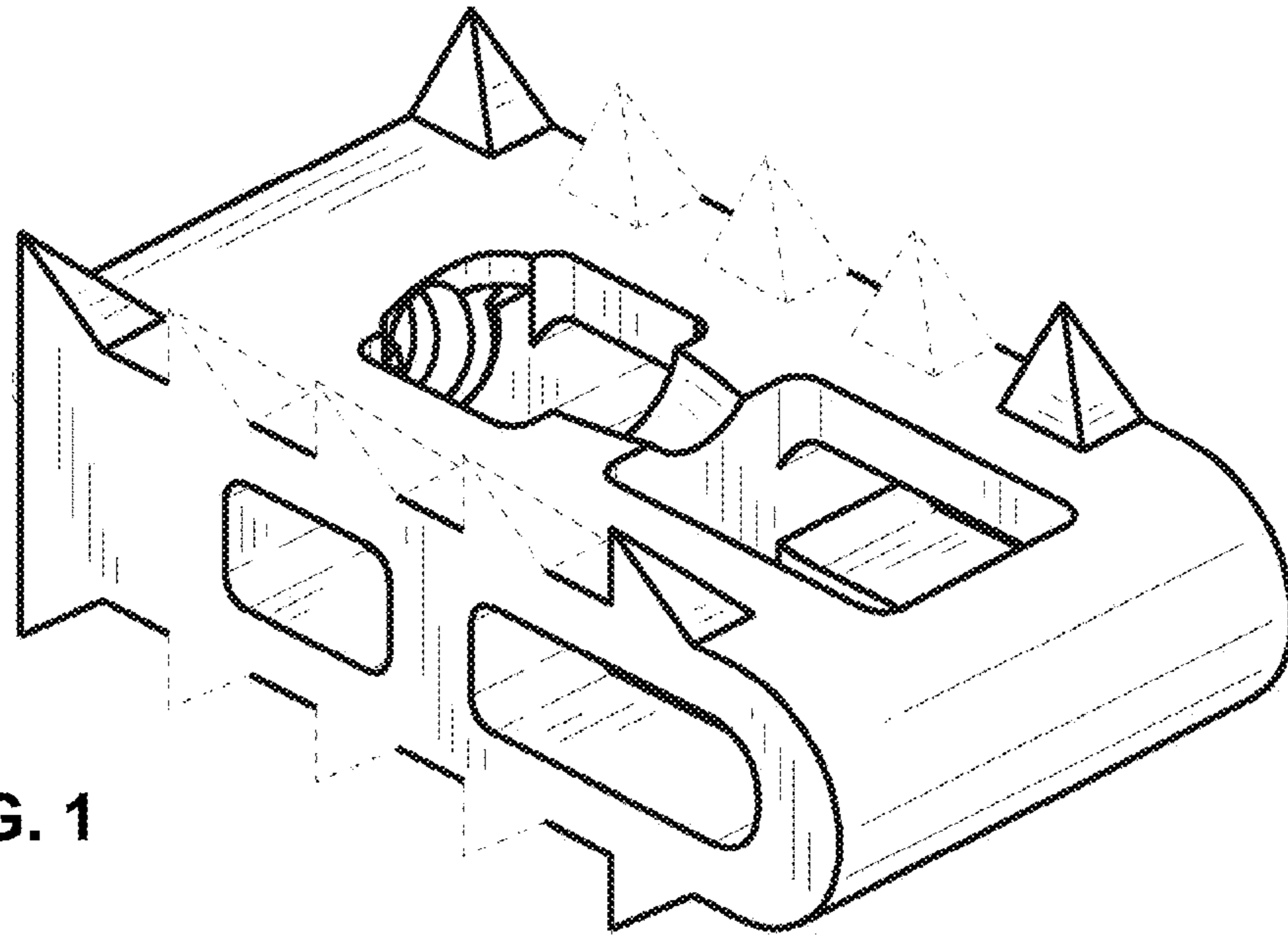

FIG. 1

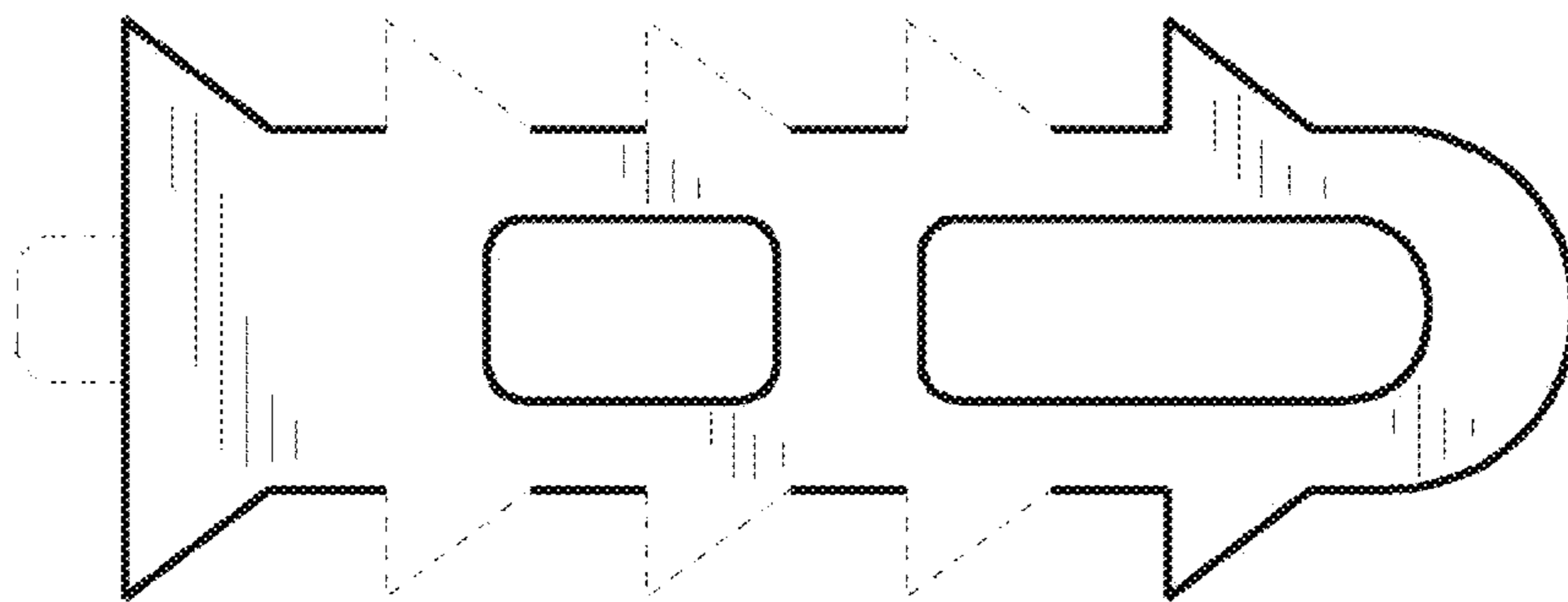

FIG. 2

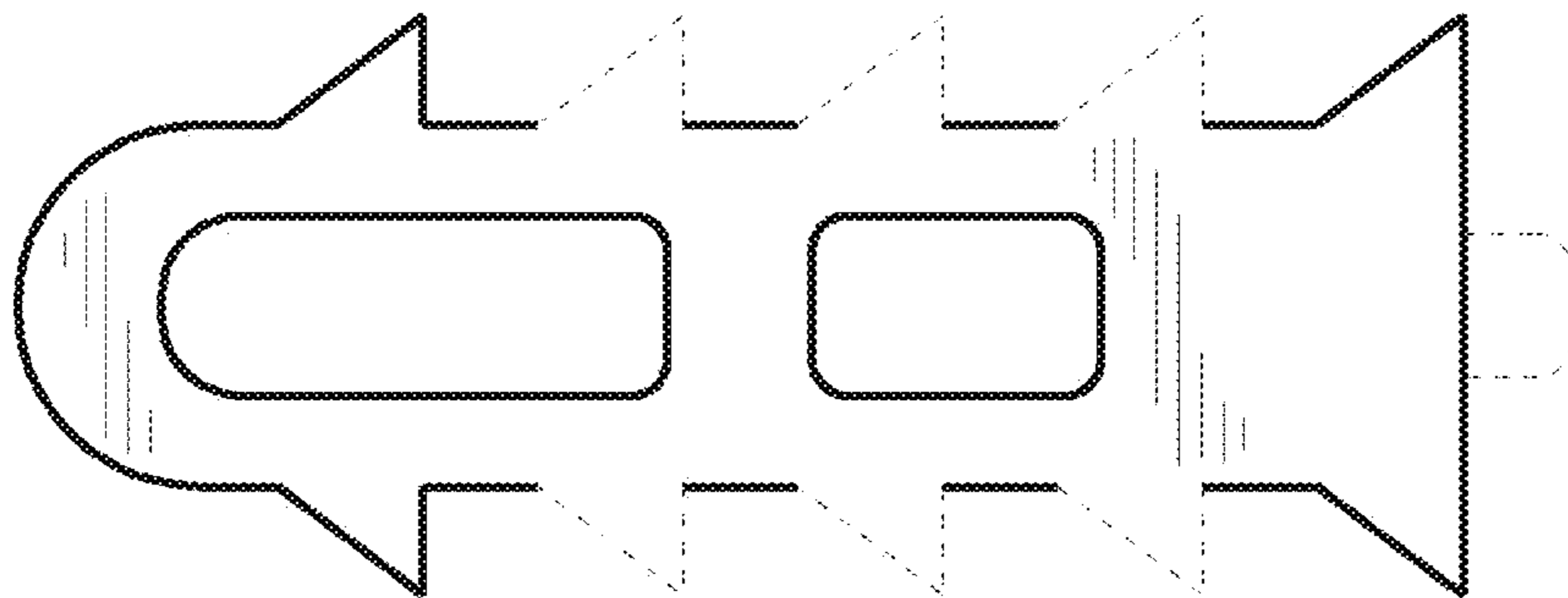

FIG. 3

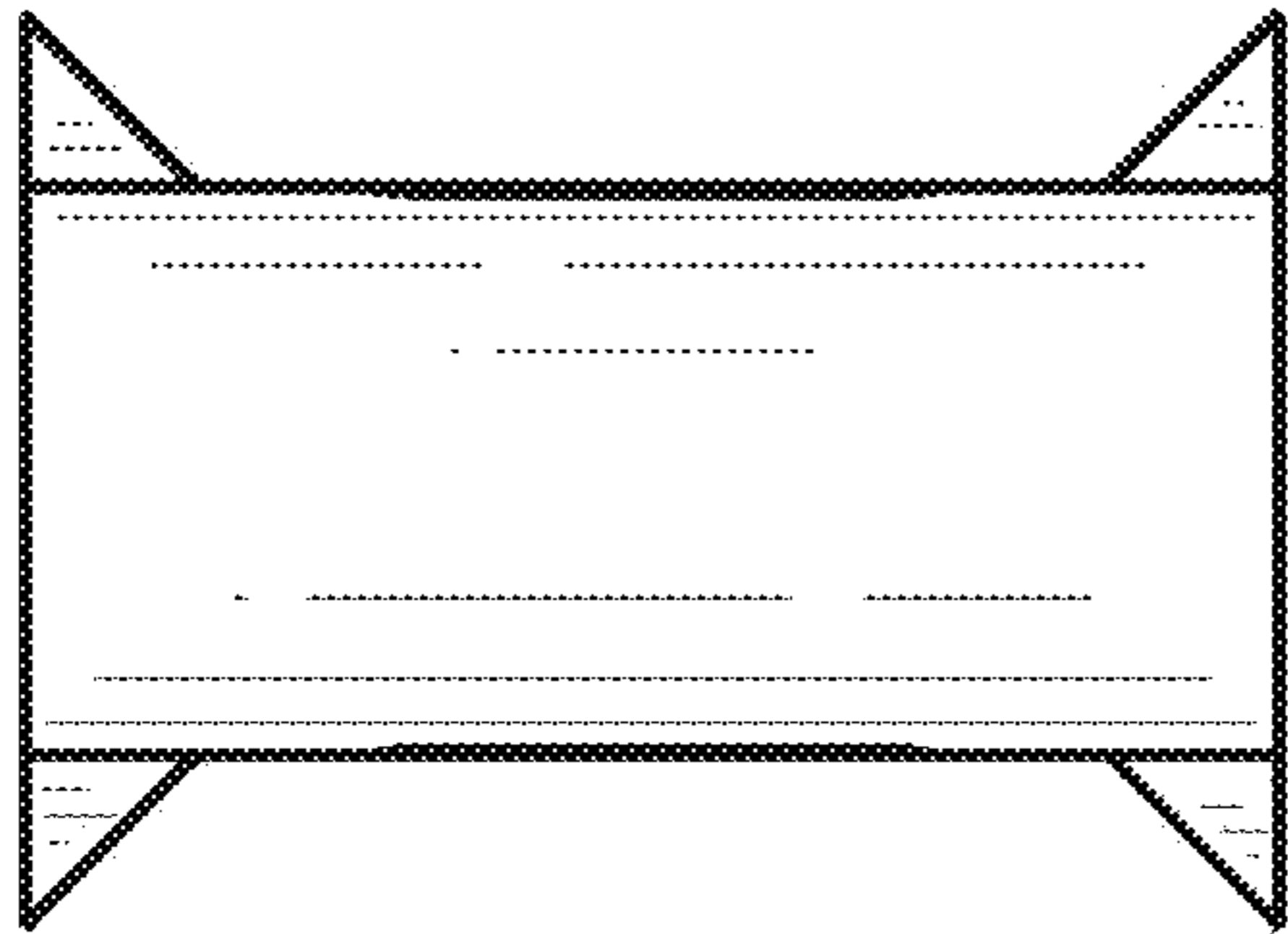

FIG. 4

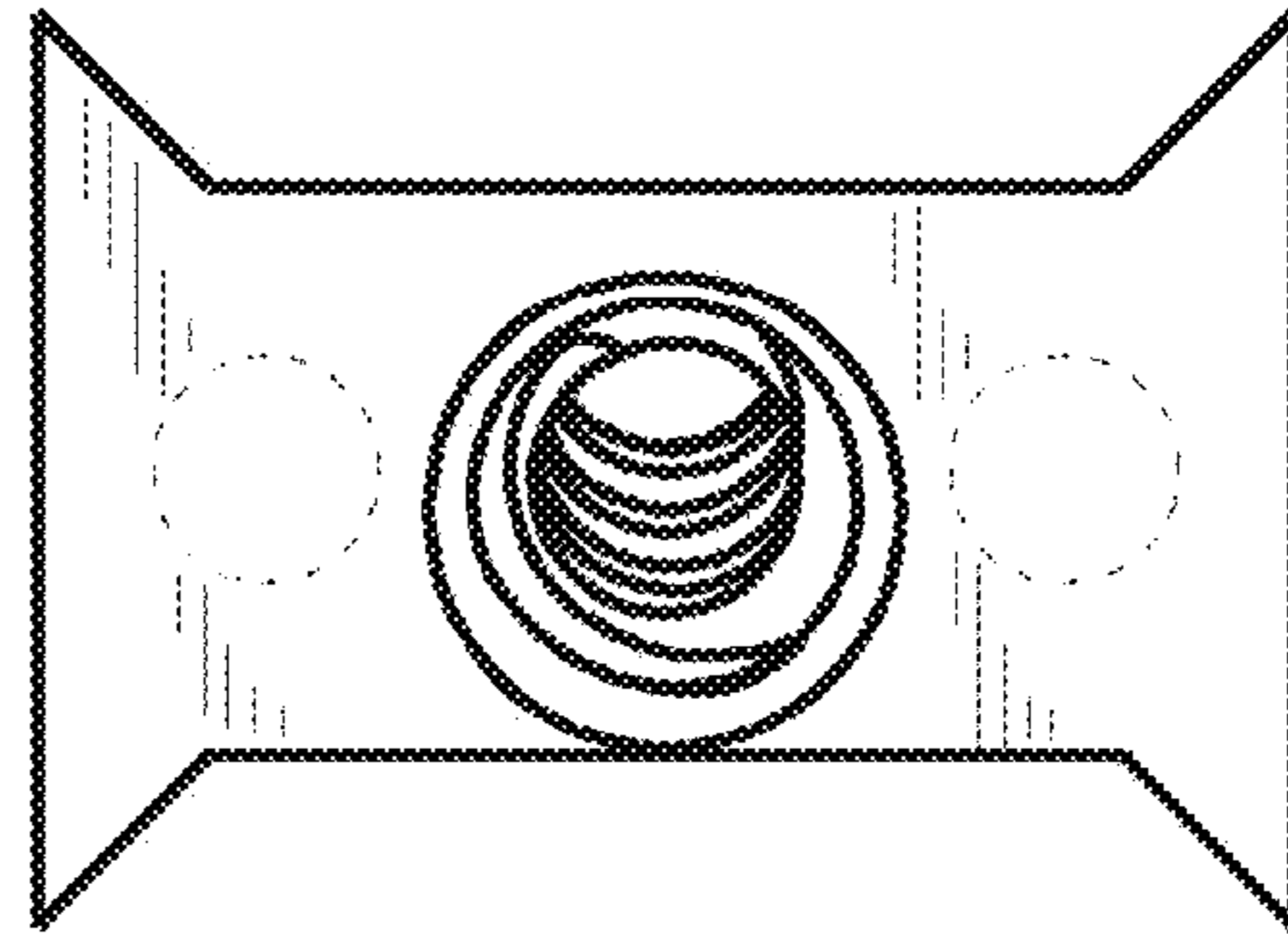

FIG. 5

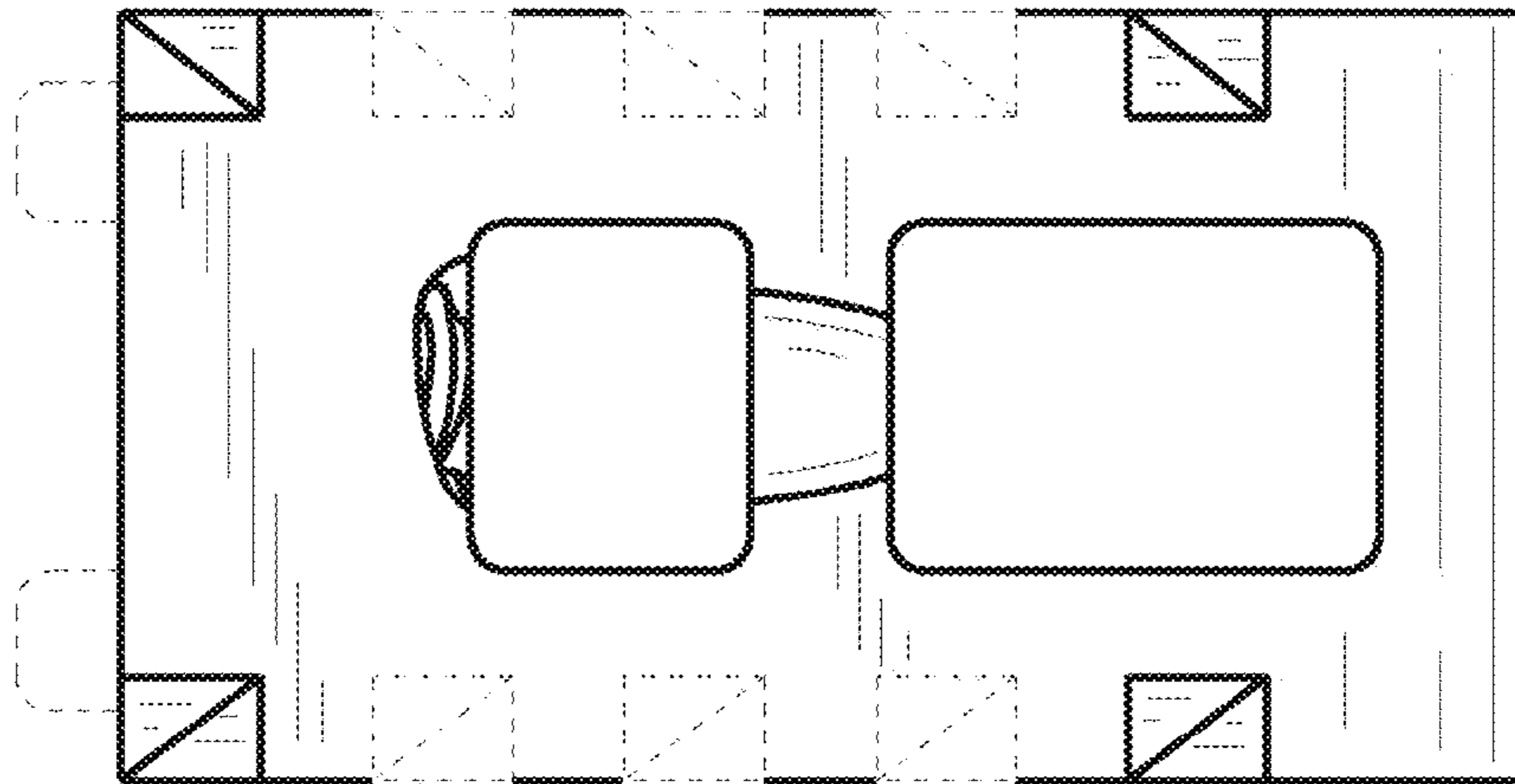

FIG. 6

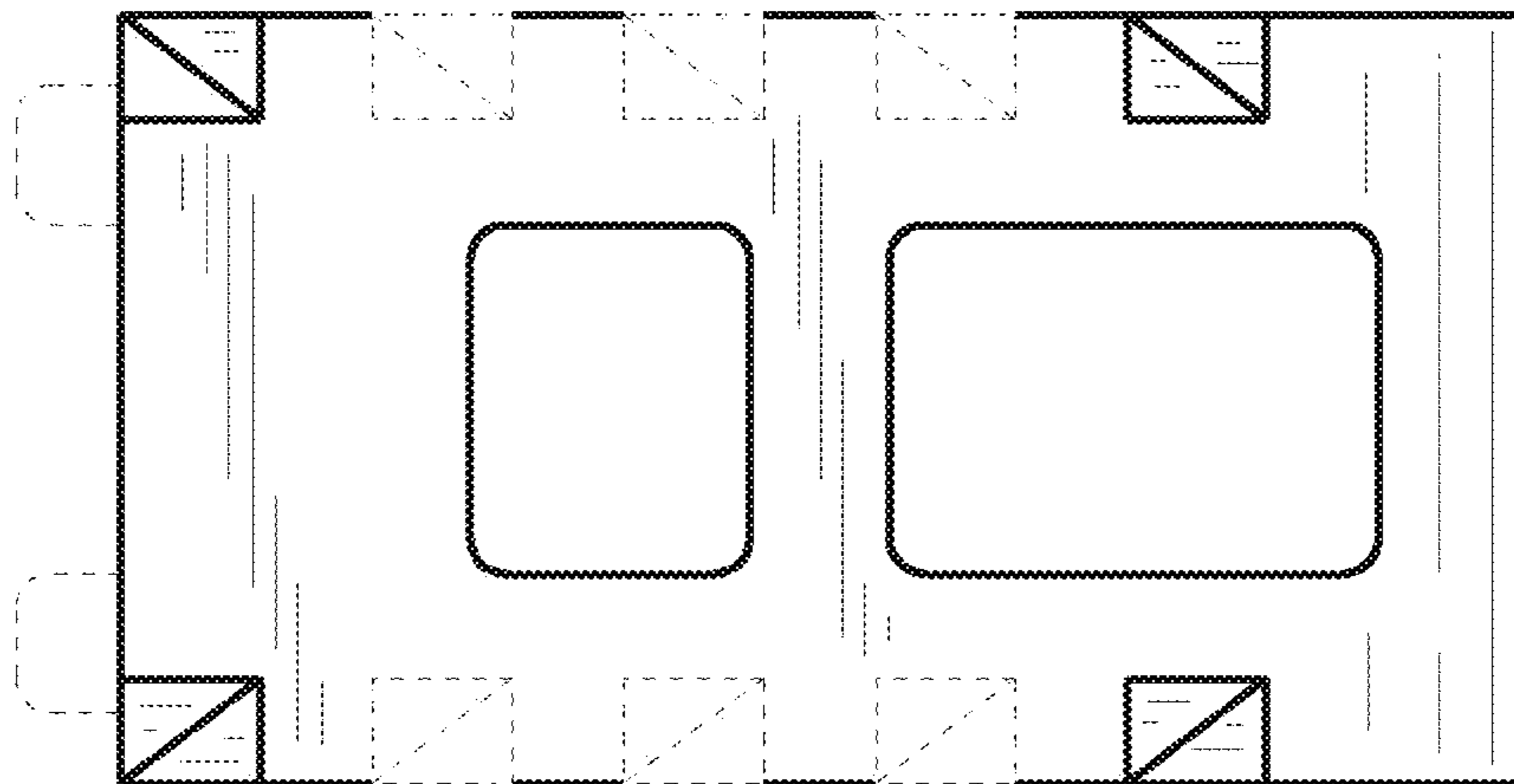

FIG. 7

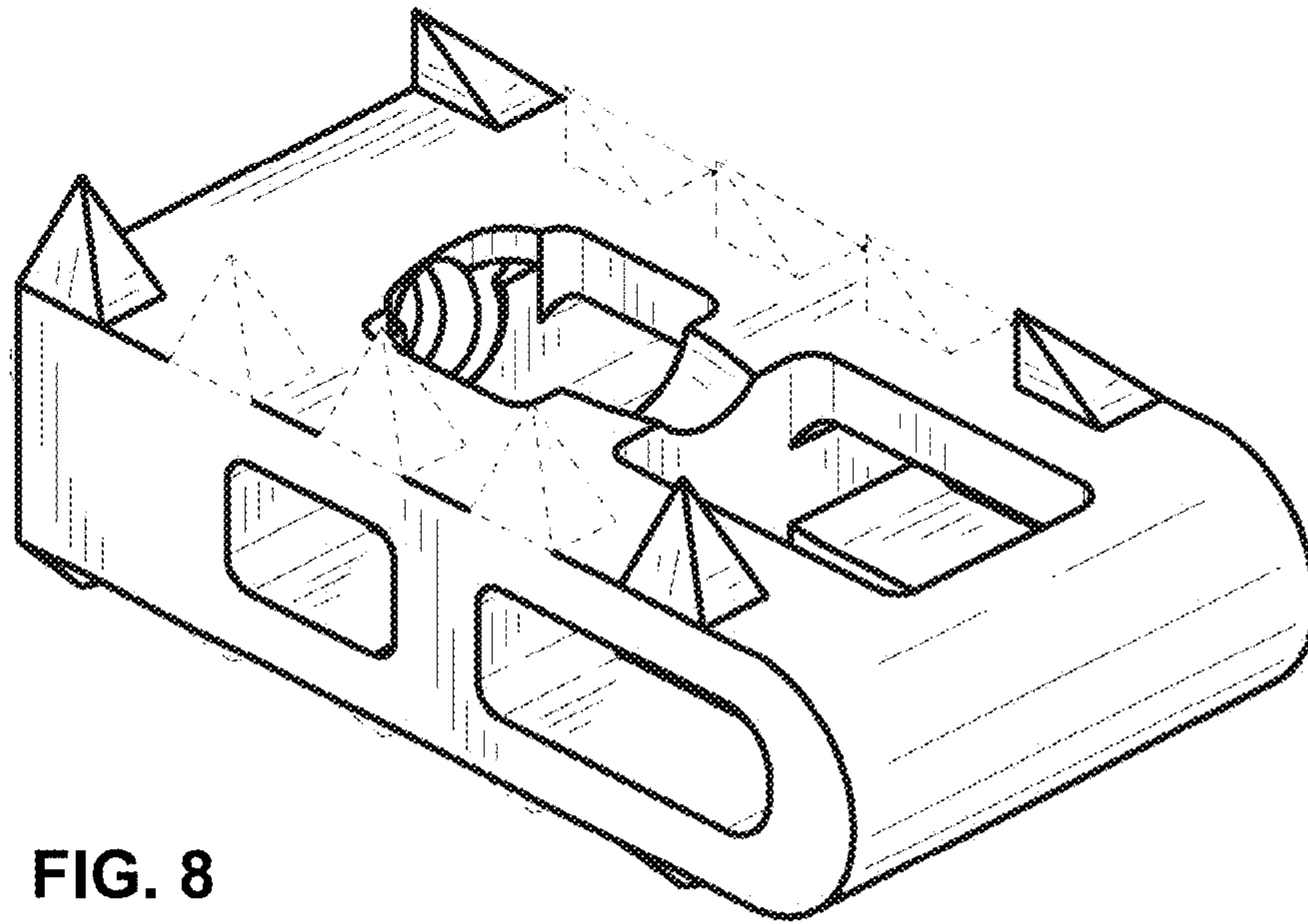

FIG. 8

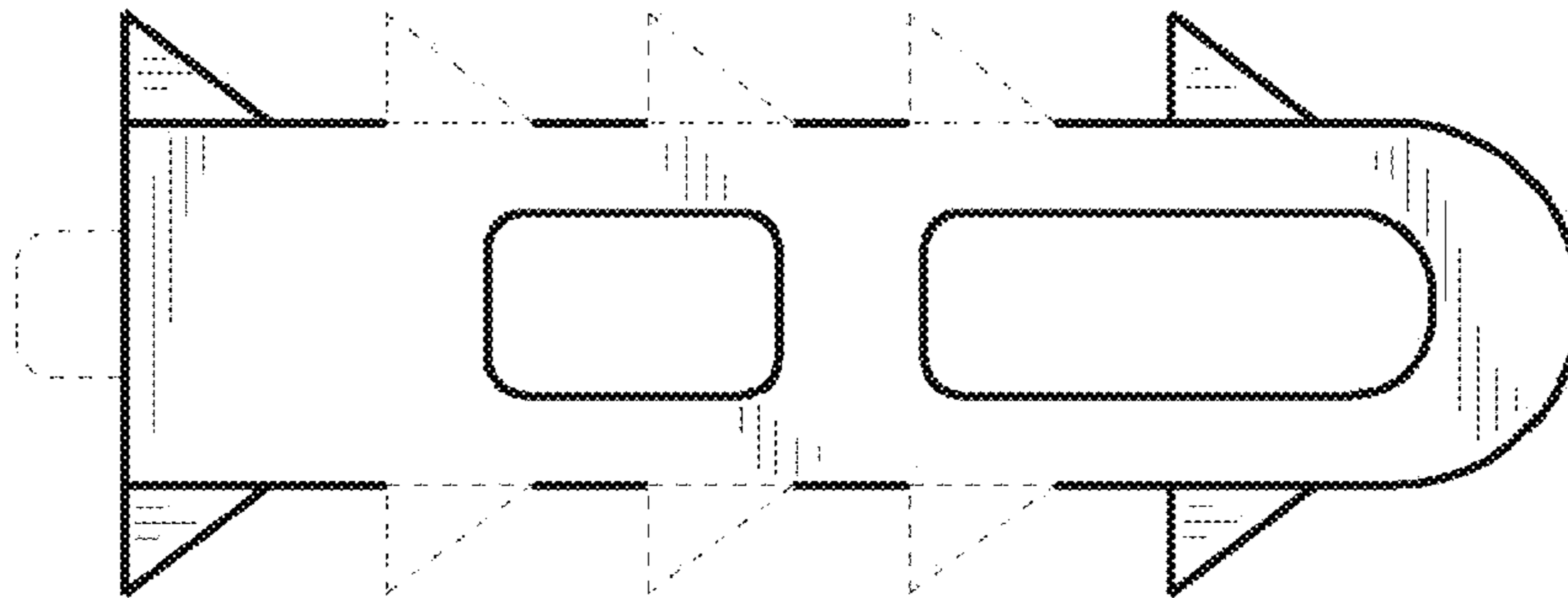

FIG. 9

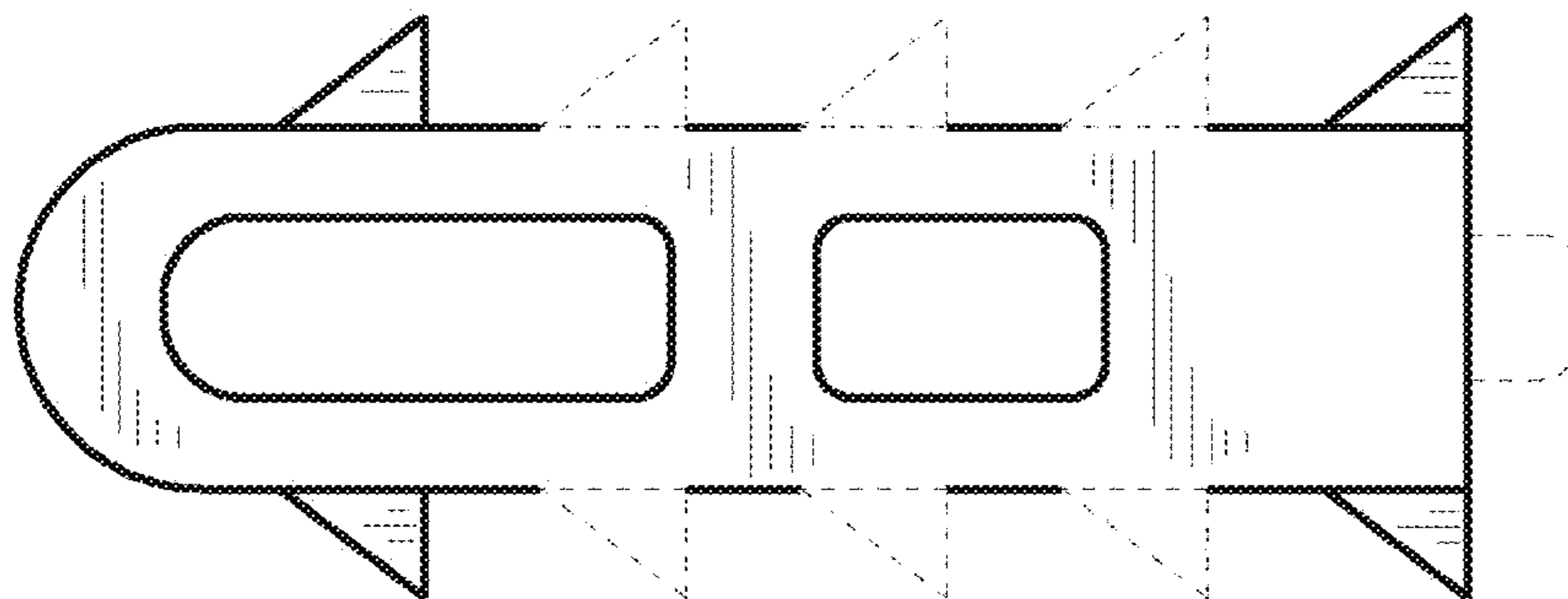

FIG. 10

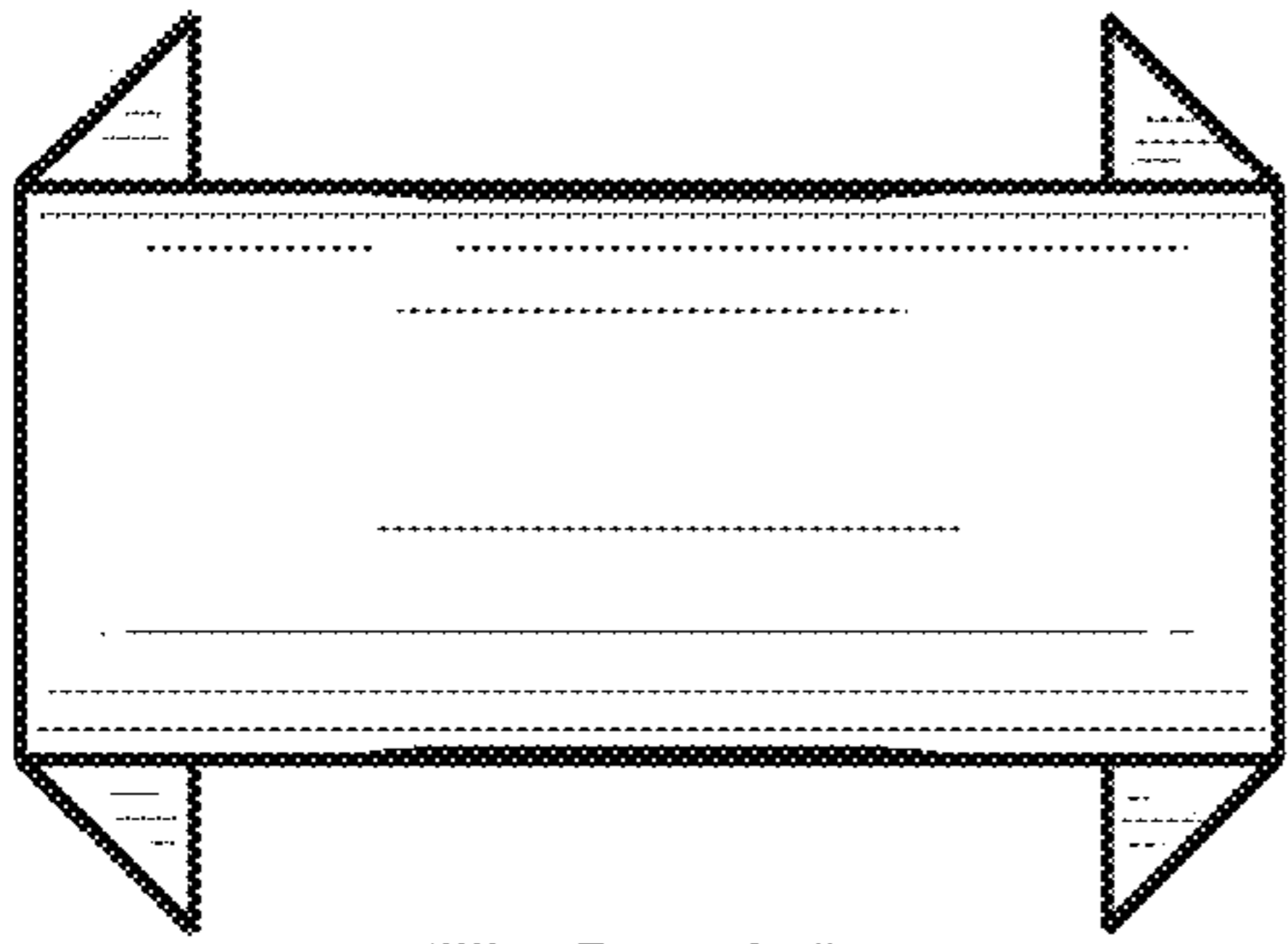

FIG. 11

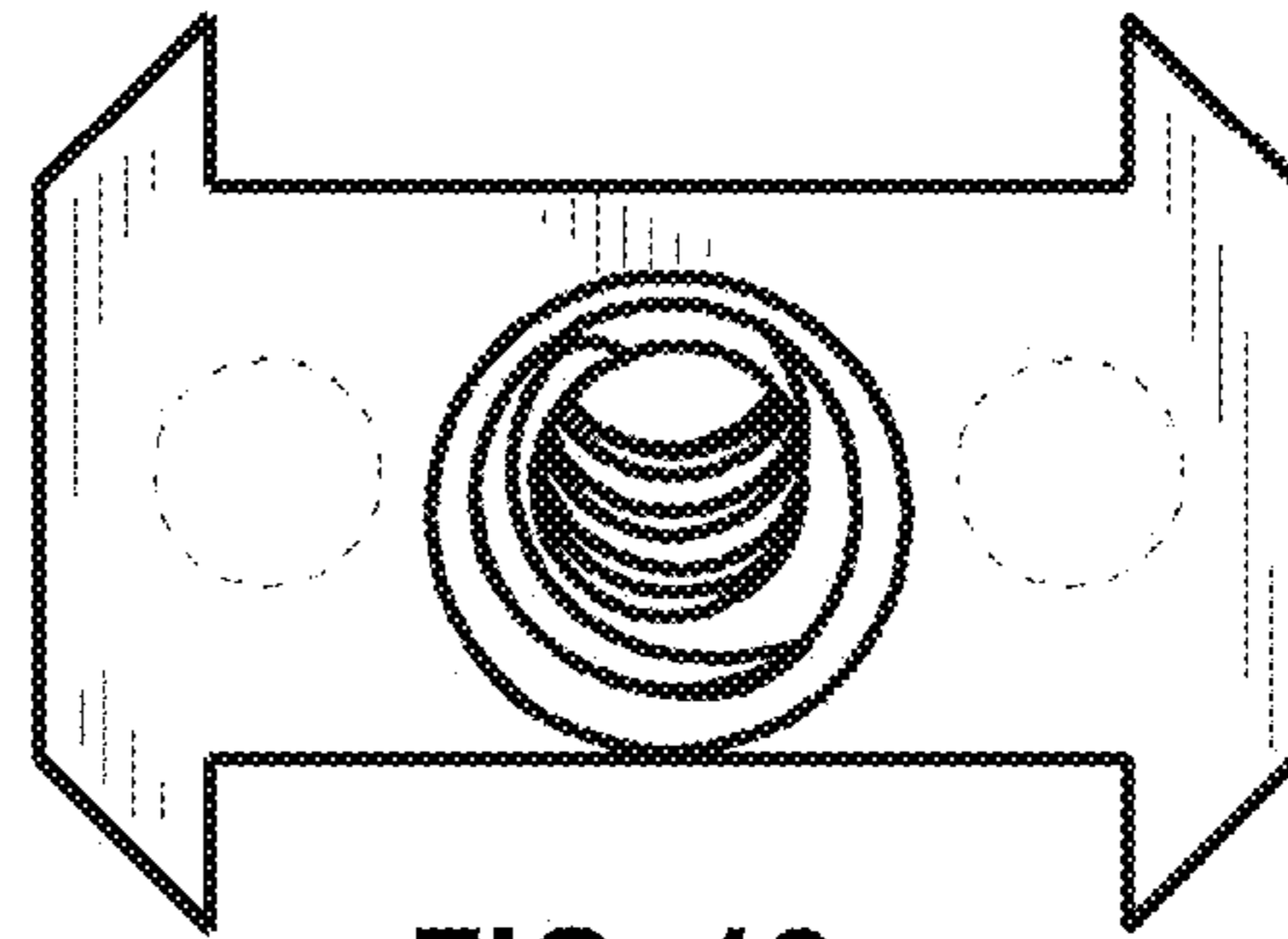

FIG. 12

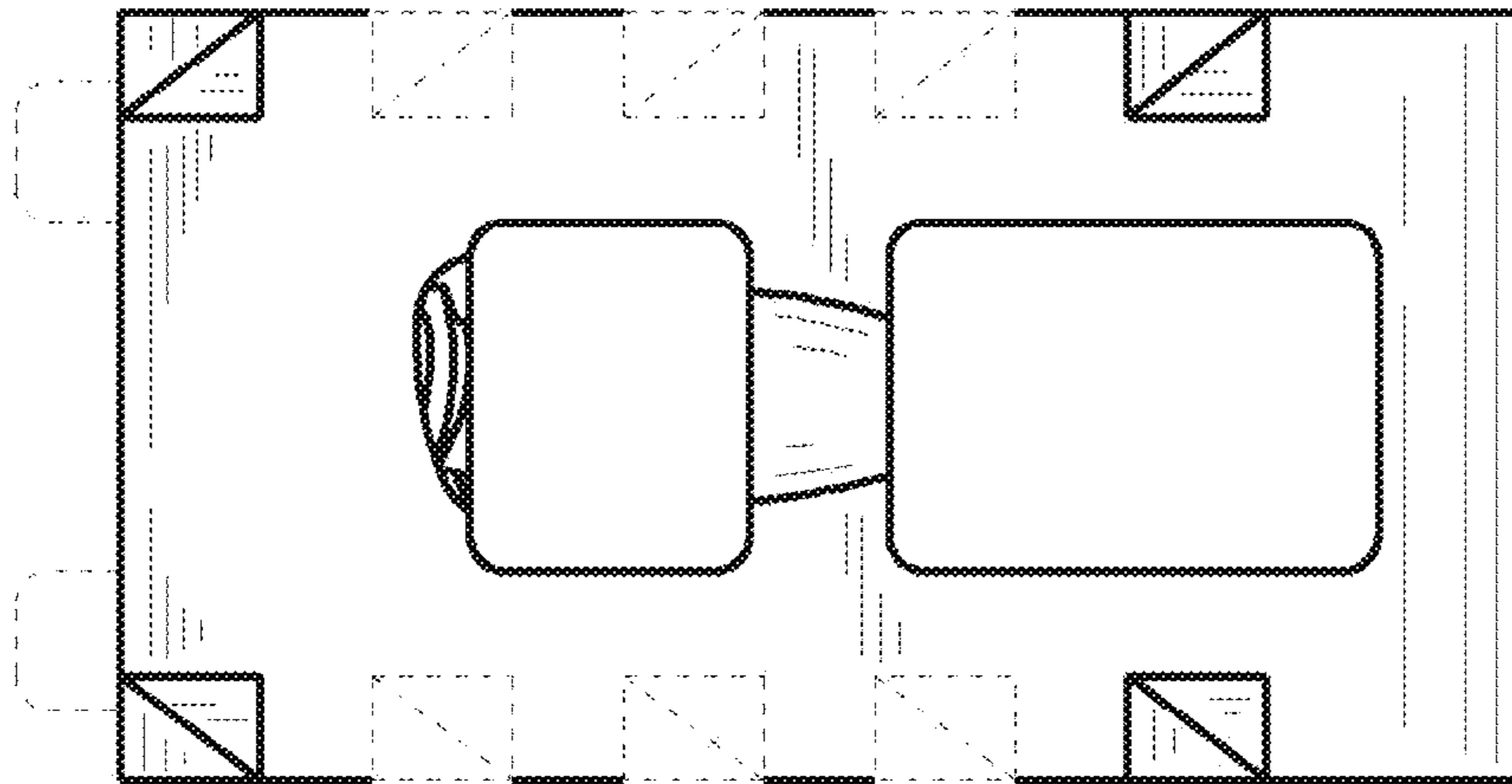

FIG. 13

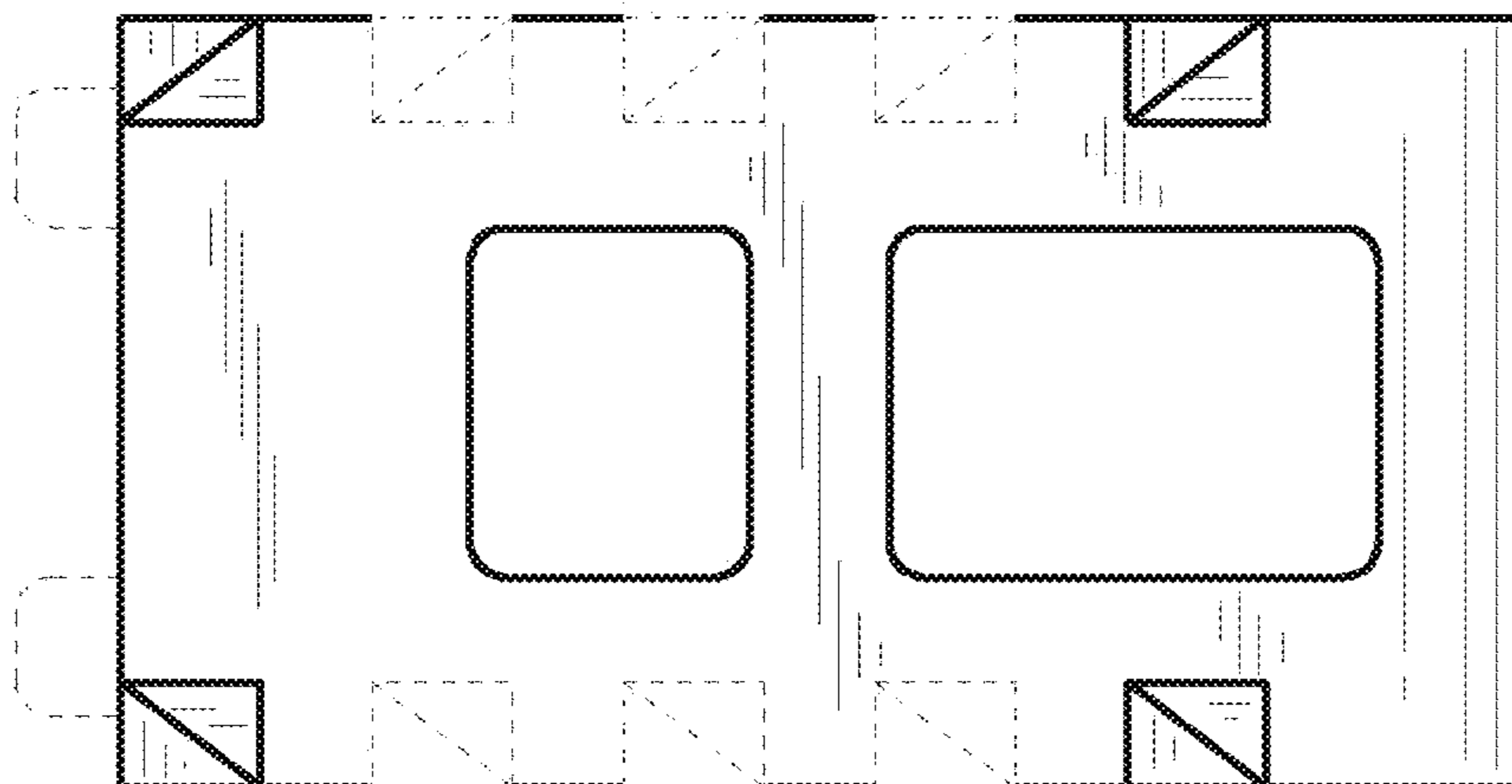

FIG. 14

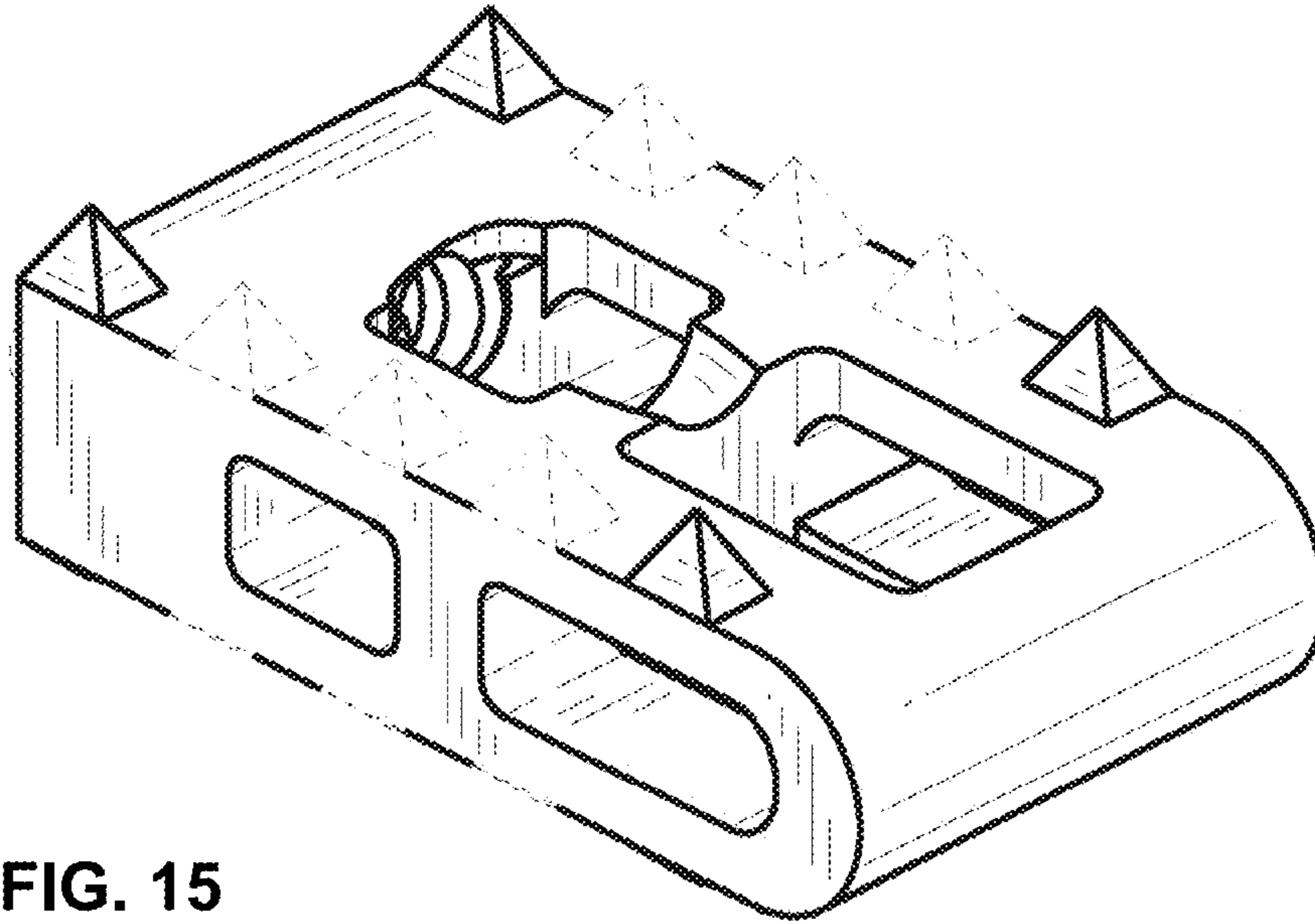

FIG. 15

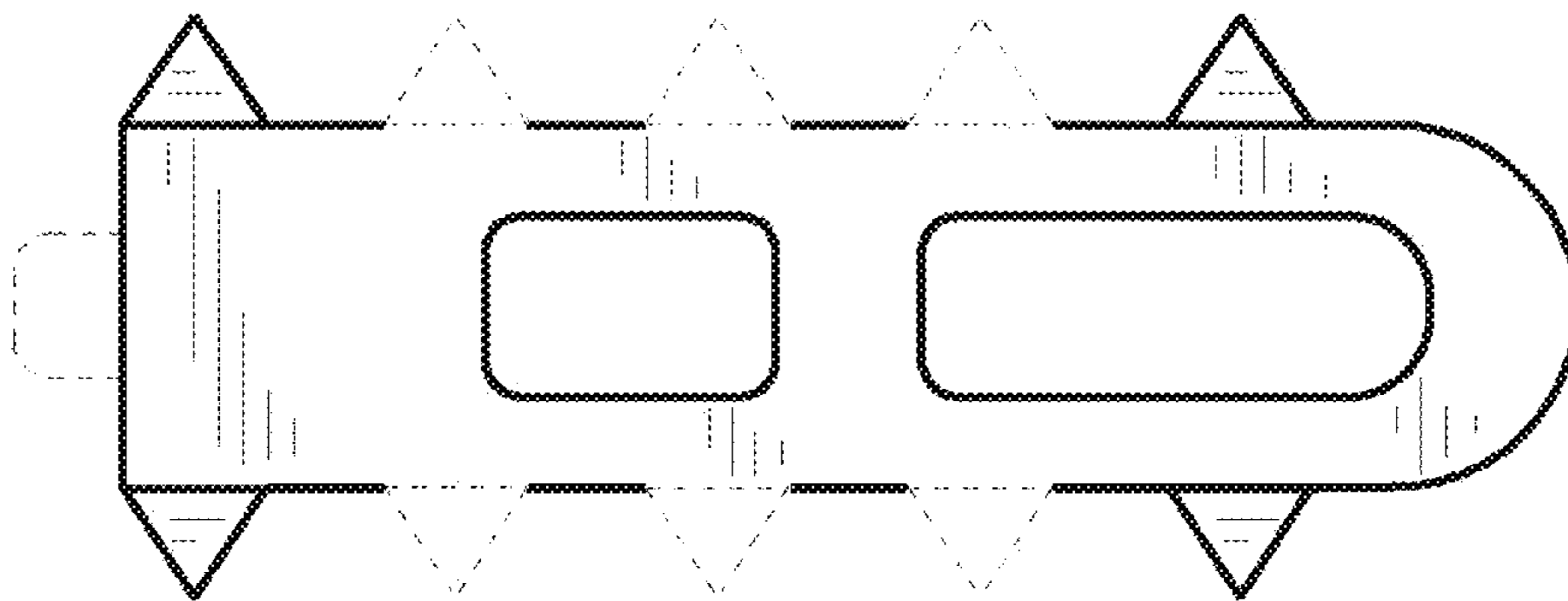

FIG. 16

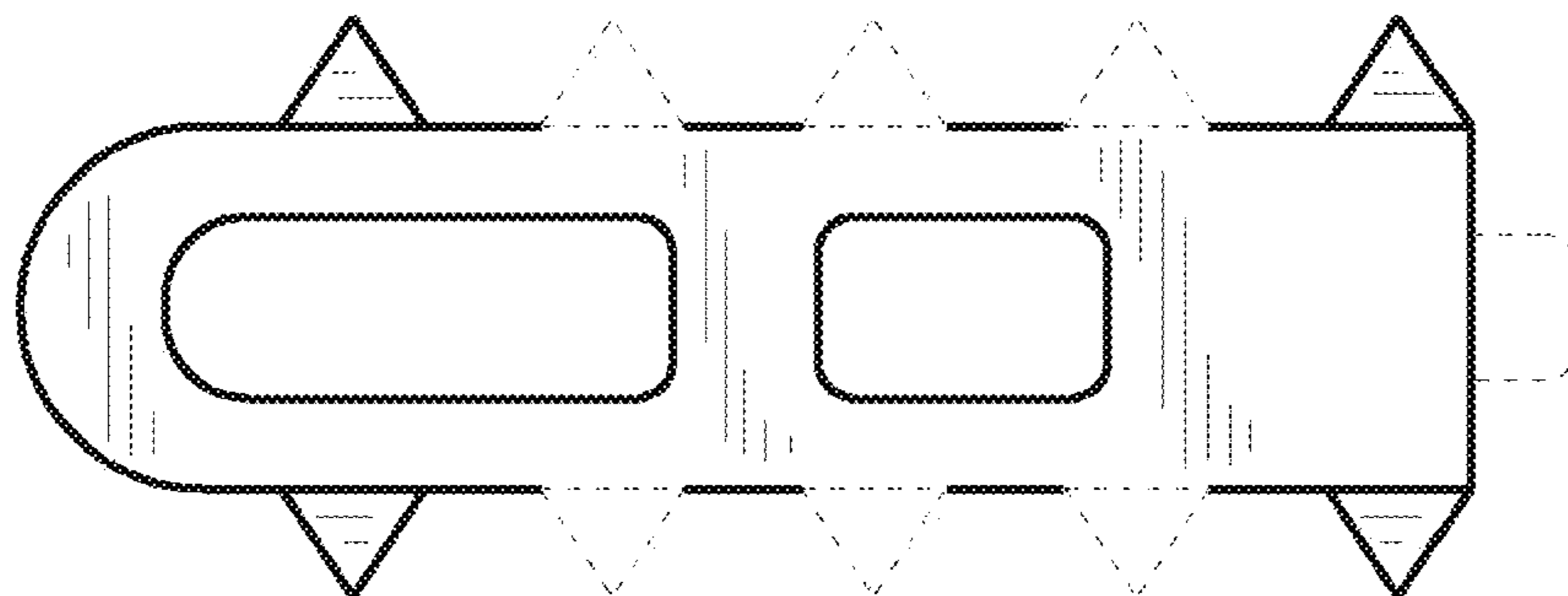

FIG. 17

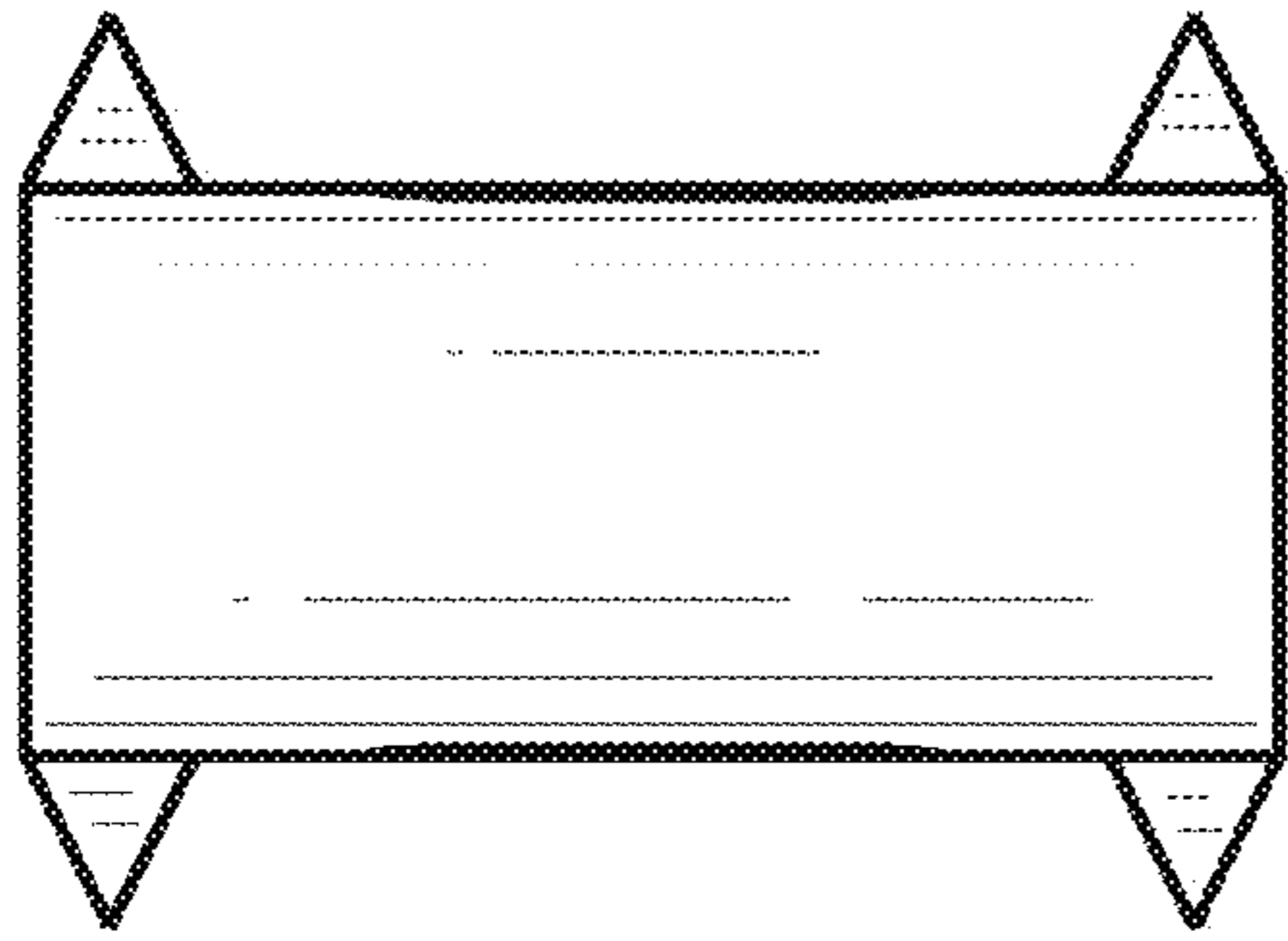

FIG. 18

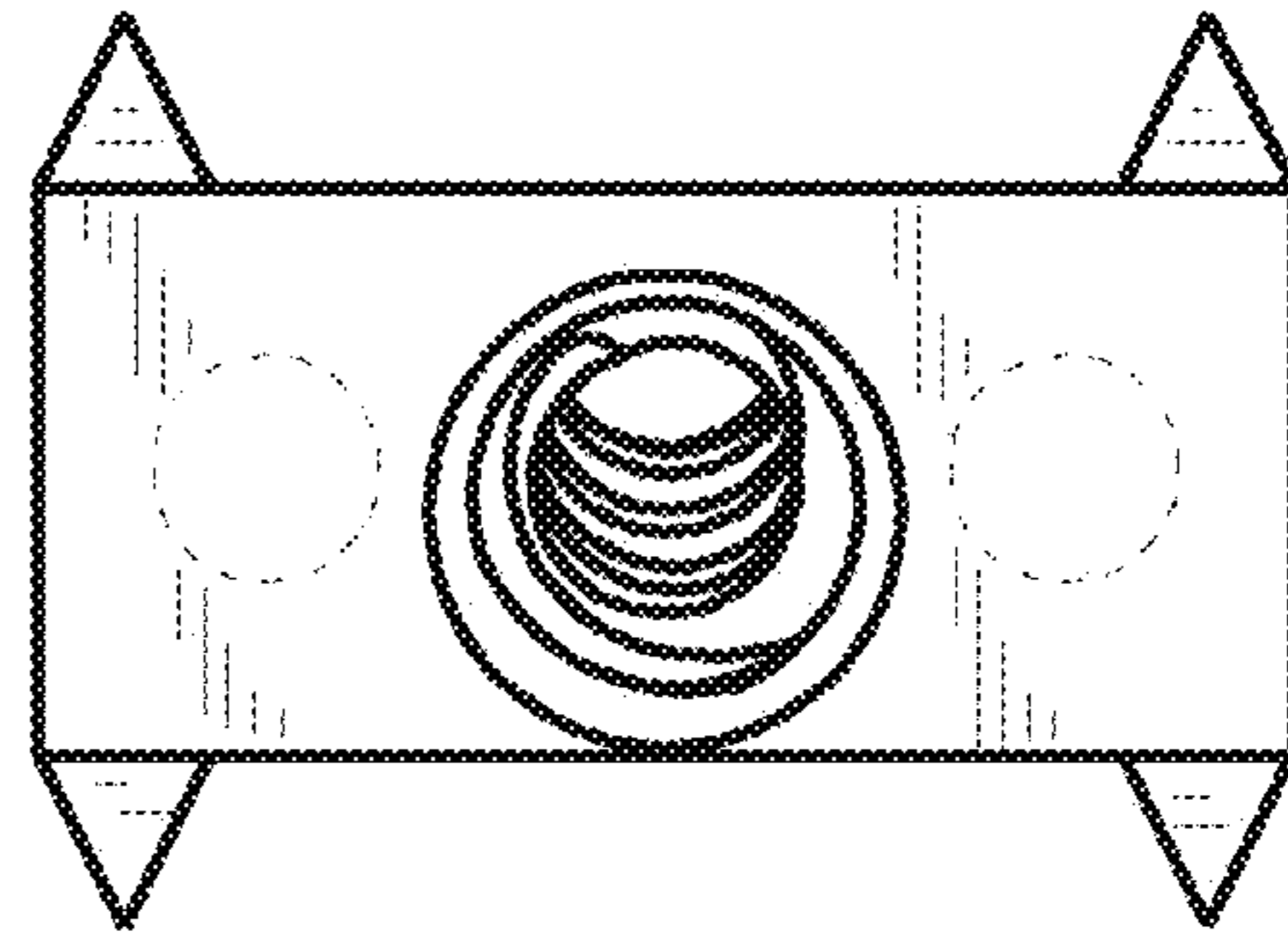

FIG. 19

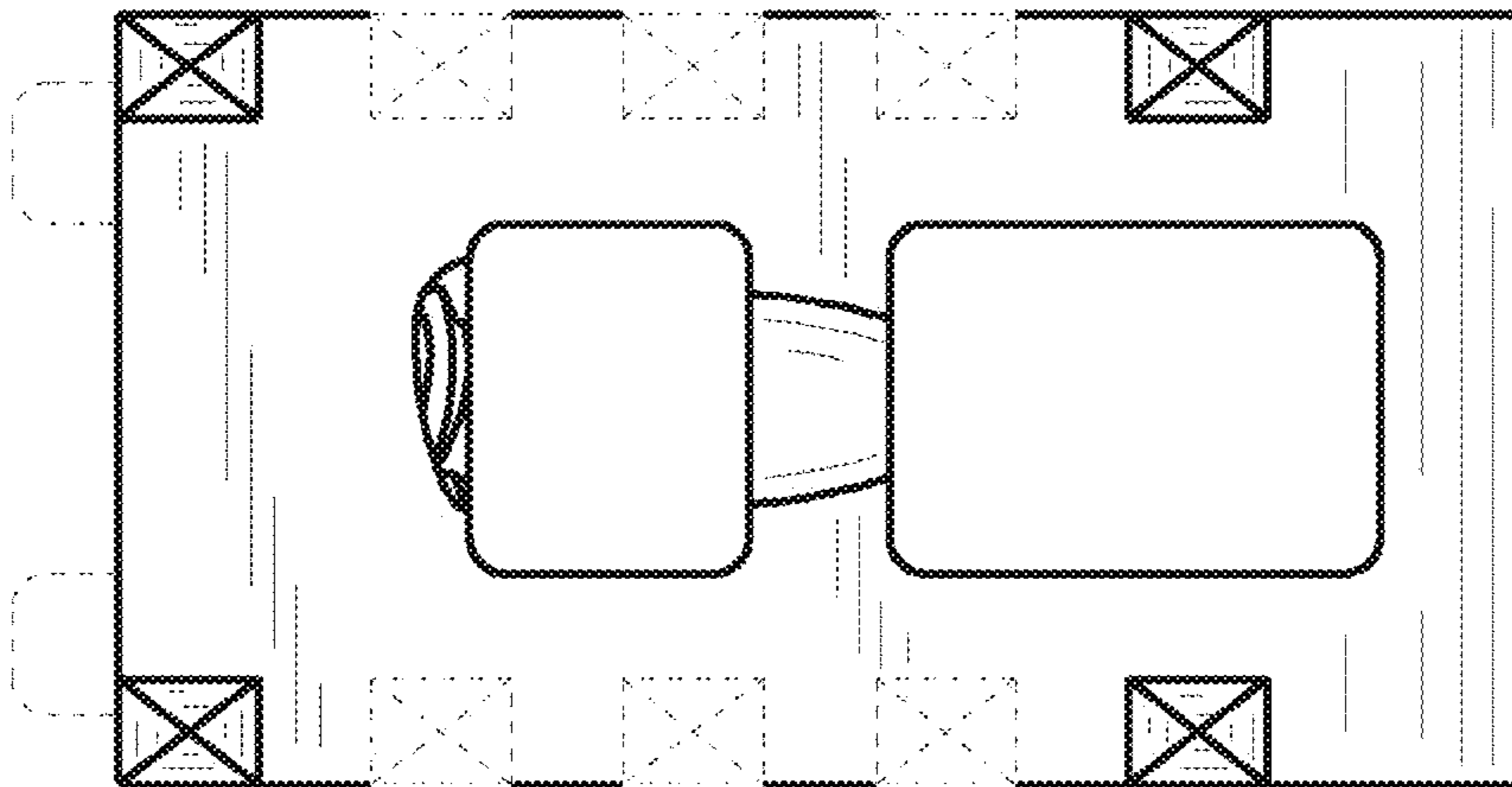

FIG. 20

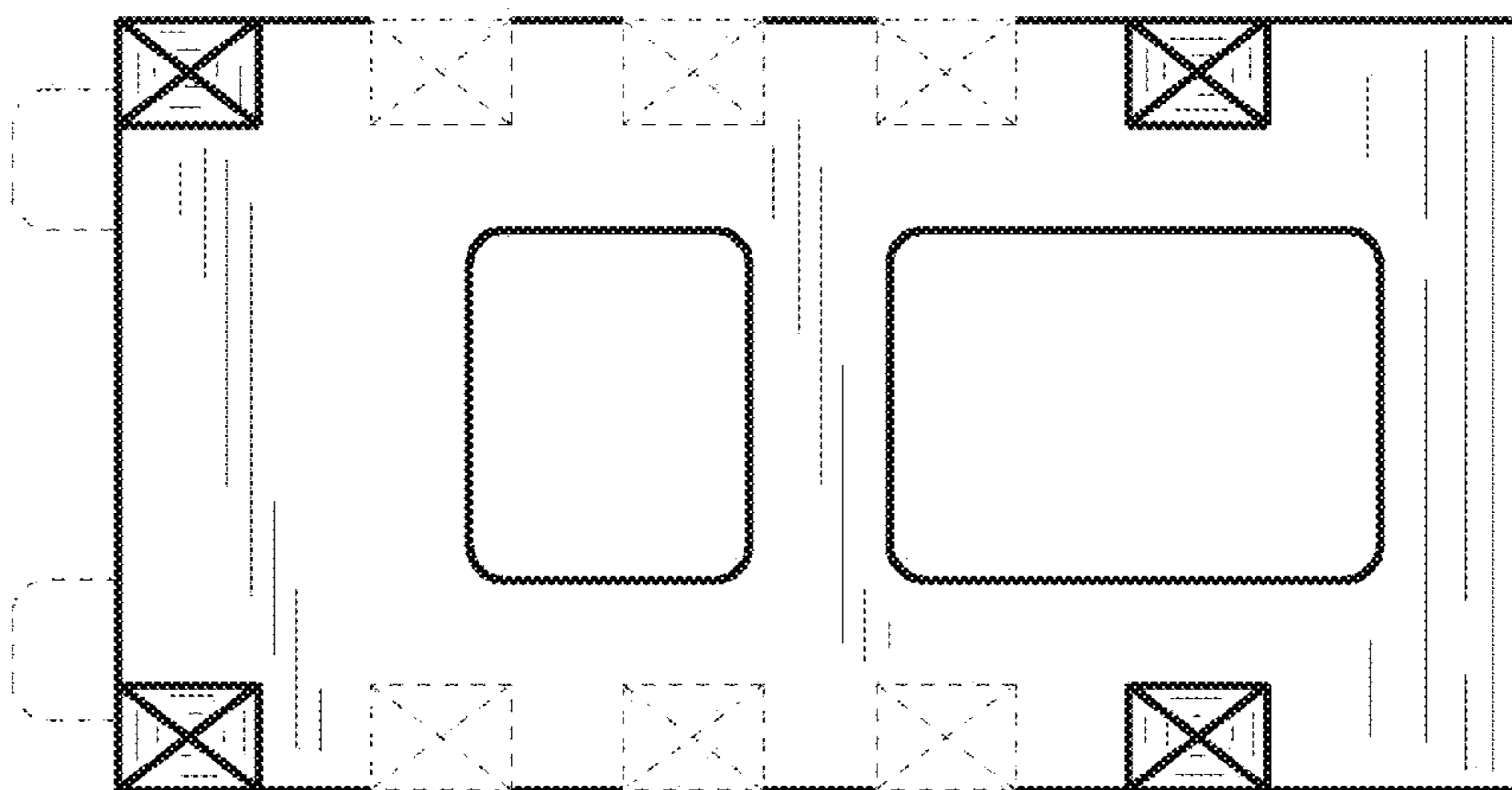

FIG. 21