



US00D884889S

(12) **United States Design Patent** (10) **Patent No.:** **US D884,889 S**
Cahill (45) **Date of Patent:** **** May 19, 2020**

(54) **CANNULATED PEDICLE SCREW TORQUE DRIVER**

(71) Applicant: **Kevin S. Cahill**, Wrightsville Beach, NC (US)

(72) Inventor: **Kevin S. Cahill**, Wrightsville Beach, NC (US)

(**) Term: **15 Years**

(21) Appl. No.: **29/685,151**

(22) Filed: **Mar. 26, 2019**

Related U.S. Application Data

(62) Division of application No. 16/224,784, filed on Dec. 18, 2018.

(51) **LOC (12) Cl.** **24-02**

(52) **U.S. Cl.**
USPC **D24/133**

(58) **Field of Classification Search**
USPC D24/133; D8/14, 21, 82, 83, 84, 85, 107, D8/300; D32/46, 48, 49; D7/395
CPC B25B 15/02; B25B 15/04; B25B 15/06; B25G 1/025; B25G 1/085; A61B 17/8875; A61B 17/8877; A61B 17/888; A61B 2017/0046; A61B 2017/00424
See application file for complete search history.

(56) **References Cited**

U.S. PATENT DOCUMENTS

D113,158 S *	1/1939	Cashmore	D8/82
3,802,518 A	4/1974	Albert		
4,078,589 A	3/1978	Miller		
D287,814 S	1/1987	Hiraishi et al.		
4,754,669 A	7/1988	Verdier		
5,016,501 A	5/1991	Holzer		
D339,279 S *	9/1993	Baum	D8/83
D392,535 S *	3/1998	Vasudeva	D8/107
5,788,021 A	8/1998	Tsai		

D409,463 S *	5/1999	McMullin	D8/21
6,151,998 A	11/2000	Fu-Hui		
6,220,368 B1	4/2001	Ark et al.		
6,273,200 B1	8/2001	Smith et al.		
7,048,107 B1	5/2006	Geis et al.		
D557,584 S	12/2007	Gao		
D613,144 S *	4/2010	Lin	D8/107
D646,385 S *	10/2011	Gauthier	D24/133
8,104,145 B1	1/2012	Hajianpour		

(Continued)

OTHER PUBLICATIONS

International Search Report and Written Opinion, PCT/US2016/068150, dated May 4, 2017.

(Continued)

Primary Examiner — Philip S Hyder

(74) *Attorney, Agent, or Firm* — Stephen R. Bylciw, Esq.

(57) **CLAIM**

The ornamental design for cannulated pedicle screw torque driver, as shown and described.

DESCRIPTION

FIG. 1 is a front view of an exemplary cannulated pedicle screw torque driver;
FIG. 2 is a top view of the cannulated pedicle screw torque driver of FIG. 1;
FIG. 3 is a bottom view of the cannulated pedicle screw torque driver of FIG. 1;
FIG. 4 is a rear view of the cannulated pedicle screw torque driver of FIG. 1;
FIG. 5 is a left view of the cannulated pedicle screw torque driver of FIG. 1; and,
FIG. 6 is a right view of the cannulated pedicle screw torque driver of FIG. 1.
Broken lines, if any included, in the drawings are for illustrative purposes only and do not form part of the claimed design.

1 Claim, 6 Drawing Sheets

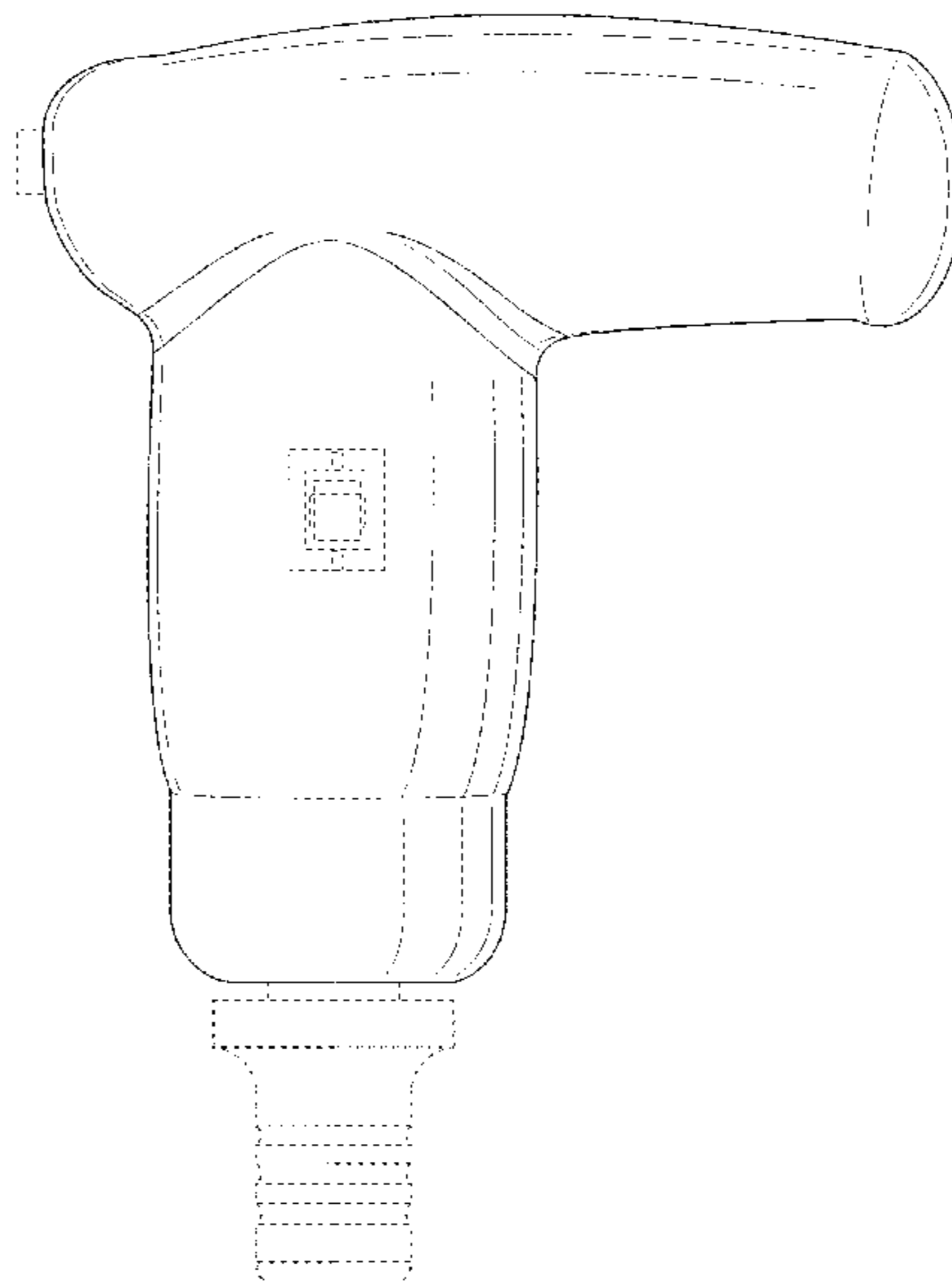

(56)

References Cited

U.S. PATENT DOCUMENTS

D654,589 S 2/2012 Bast et al.
D673,832 S * 1/2013 Molina D8/83
8,601,916 B2 * 12/2013 Chen B25G 1/005
7/143
8,651,198 B2 2/2014 Ito
D734,115 S * 7/2015 Robinson D8/83
D784,105 S * 4/2017 Nelson D8/83
2007/0132196 A1 6/2007 Puzio et al.
2009/0254094 A1 * 10/2009 Knapp A61B 17/1637
606/96
2009/0299439 A1 12/2009 Mire et al.
2010/0179560 A1 7/2010 Chenaux
2012/0046665 A1 2/2012 Kim
2012/0109143 A1 5/2012 Steele et al.

OTHER PUBLICATIONS

“Black and Decker Gyro Screwdriver—M3 Design Product Teardown,”
M3 Design, (downloaded from internet at: [cdn1.m3design.com/
wordpress/wp-content/uploads/2014/09/M3-Teardown-Black-Decker-
Gyro-Screwdriver.pdf](http://cdn1.m3design.com/wordpress/wp-content/uploads/2014/09/M3-Teardown-Black-Decker-Gyro-Screwdriver.pdf)), dated Sep. 2014.

* cited by examiner

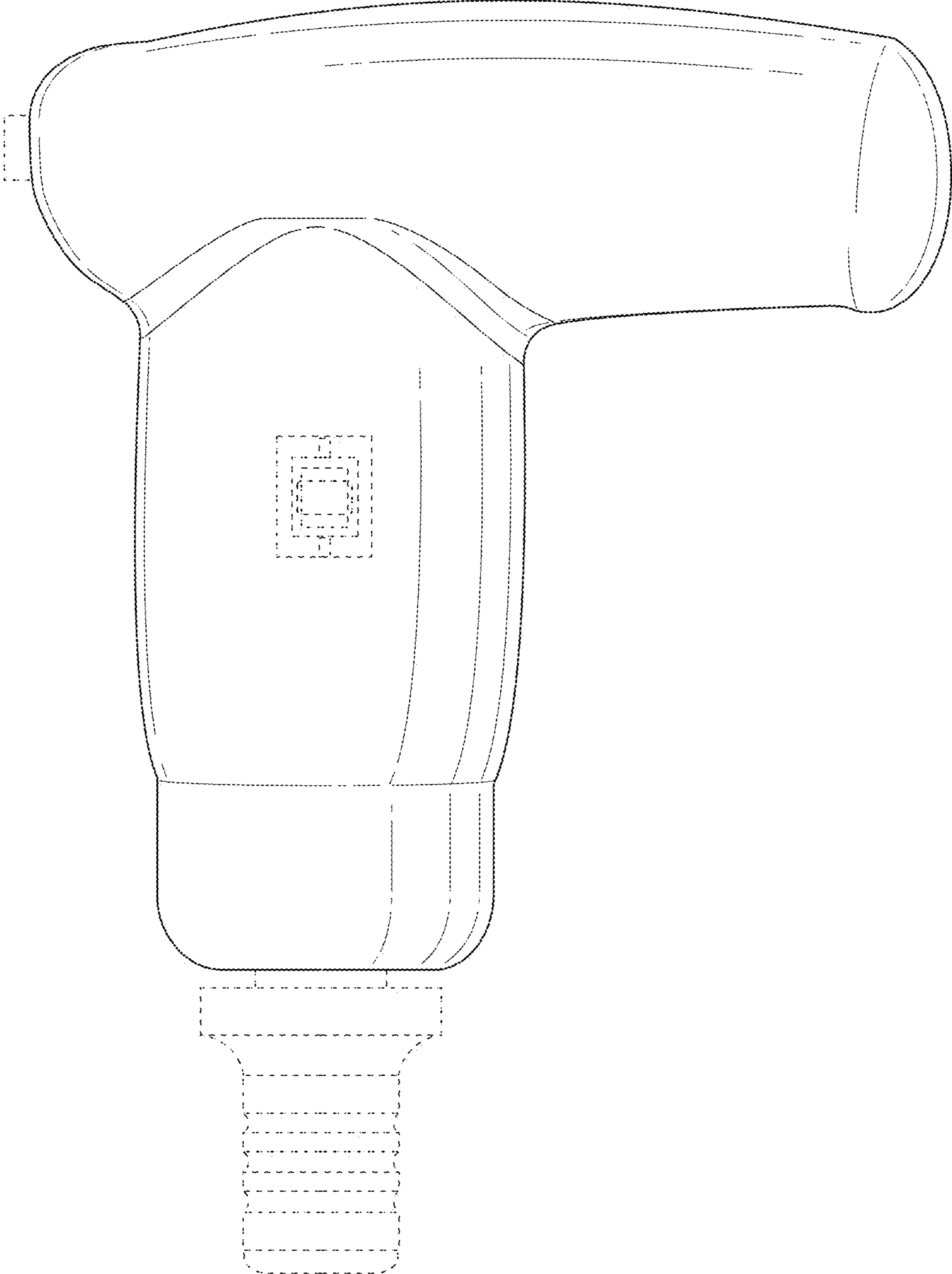

FIG. 1

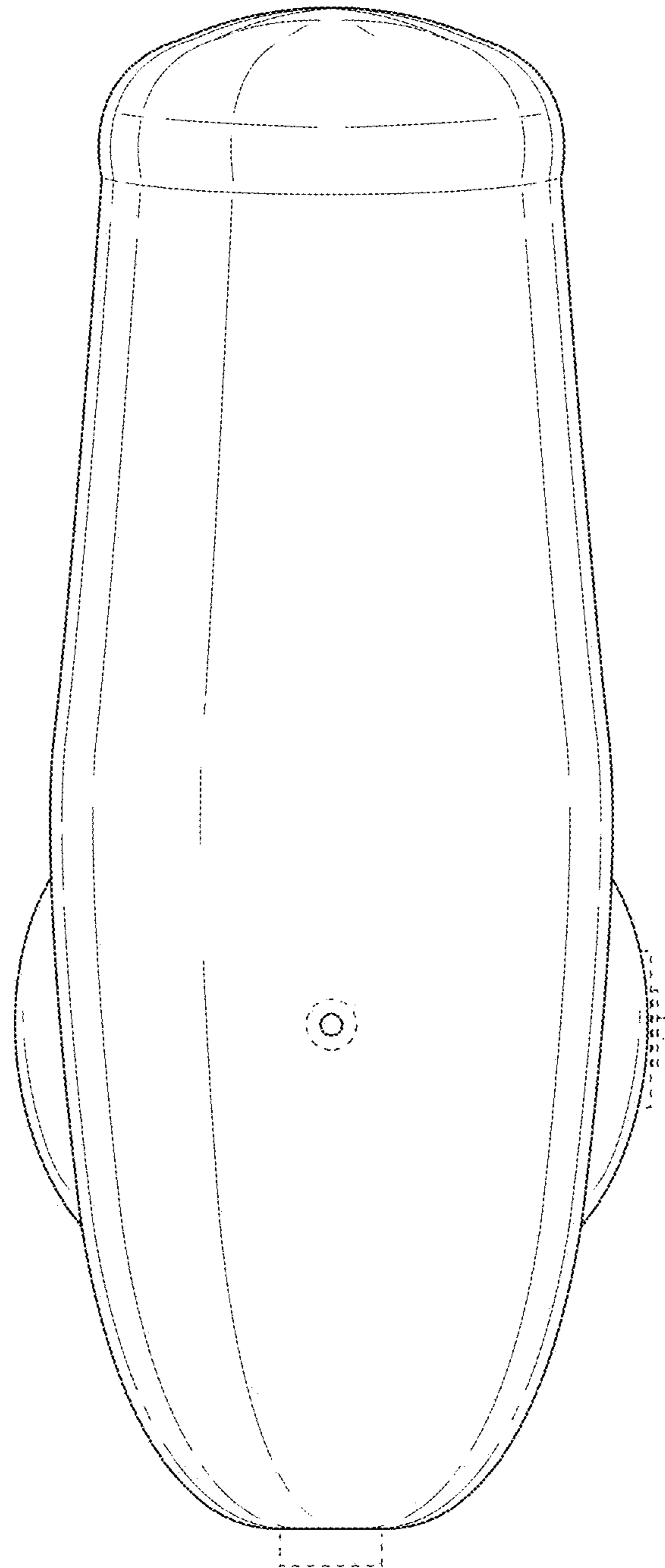

FIG. 2

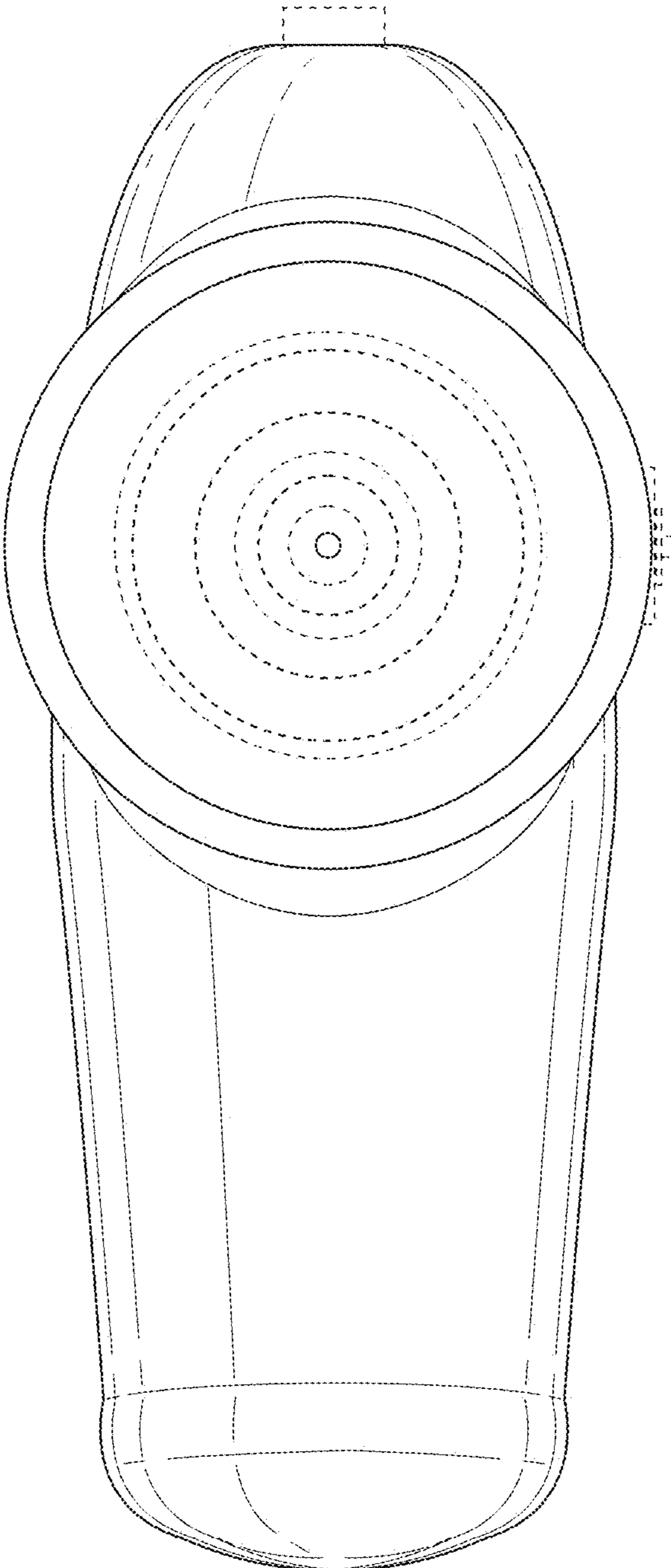

FIG. 3

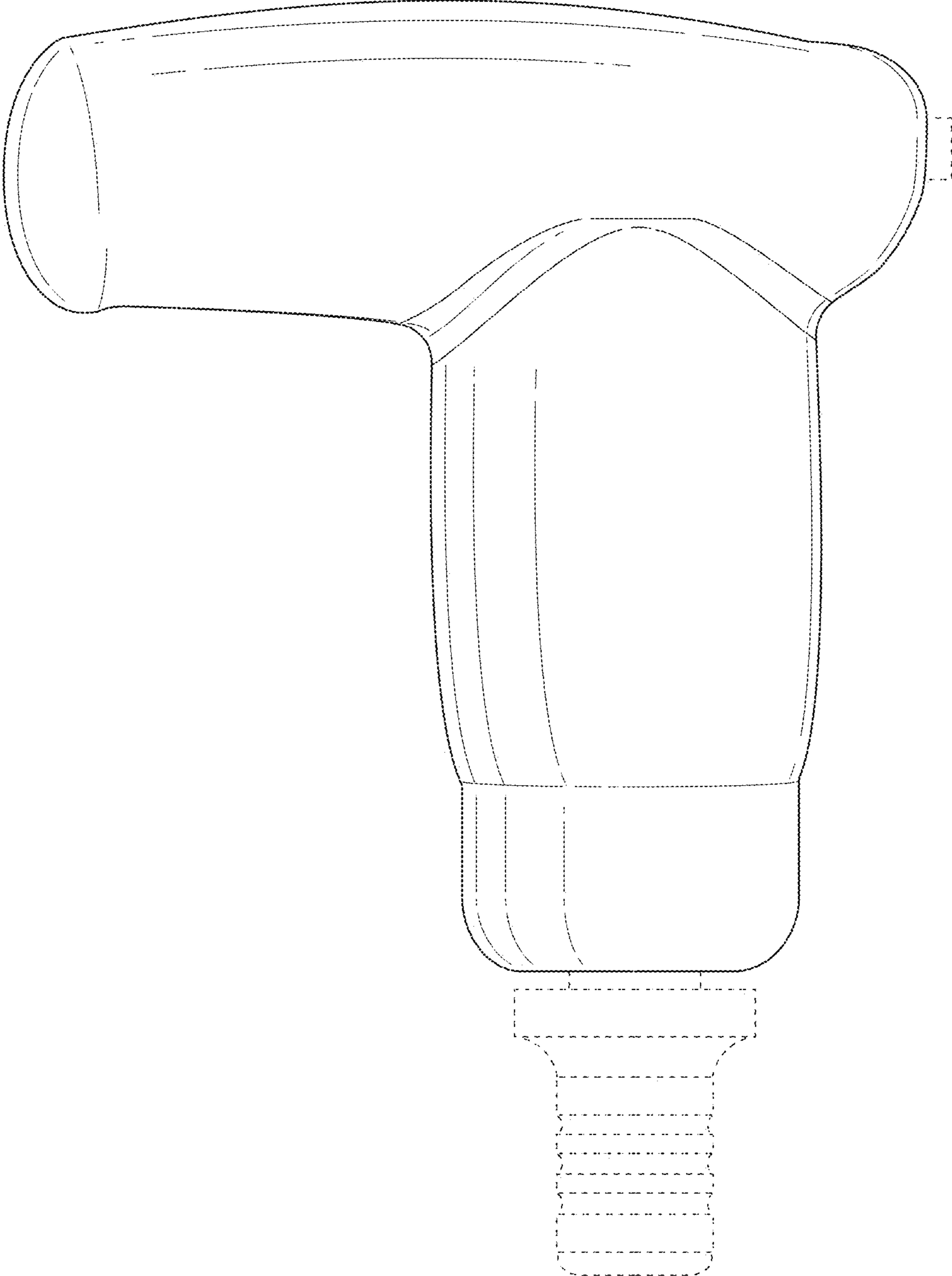

FIG. 4

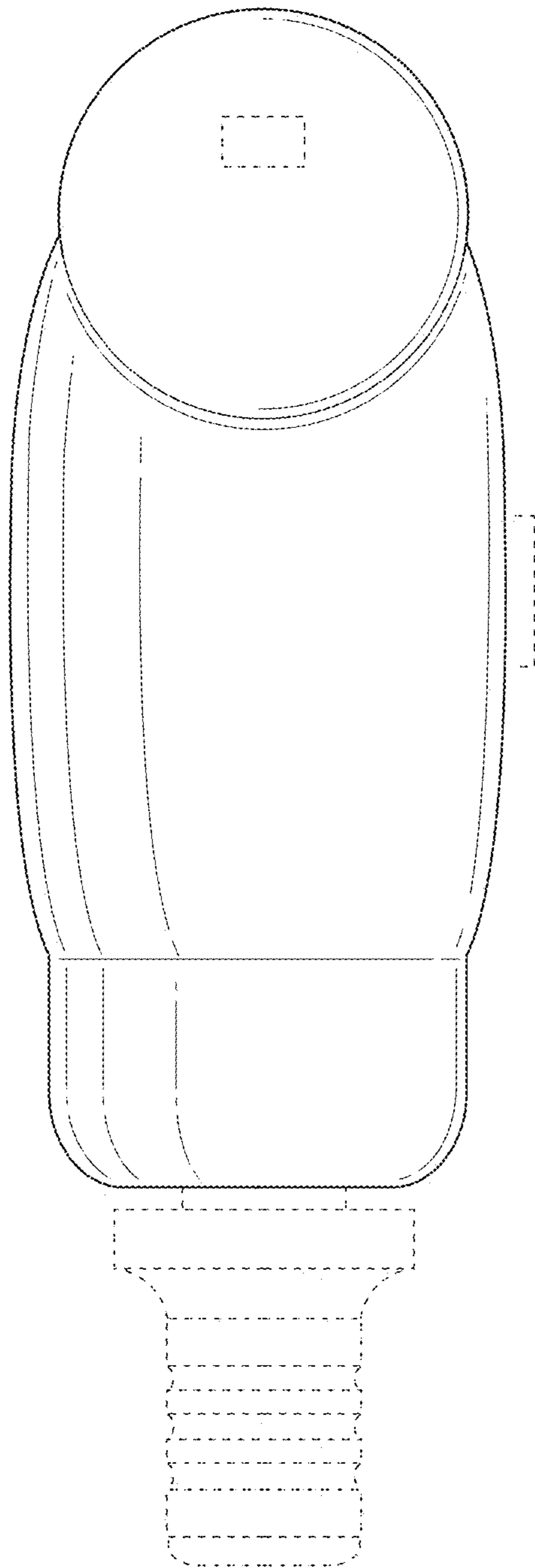

FIG. 5

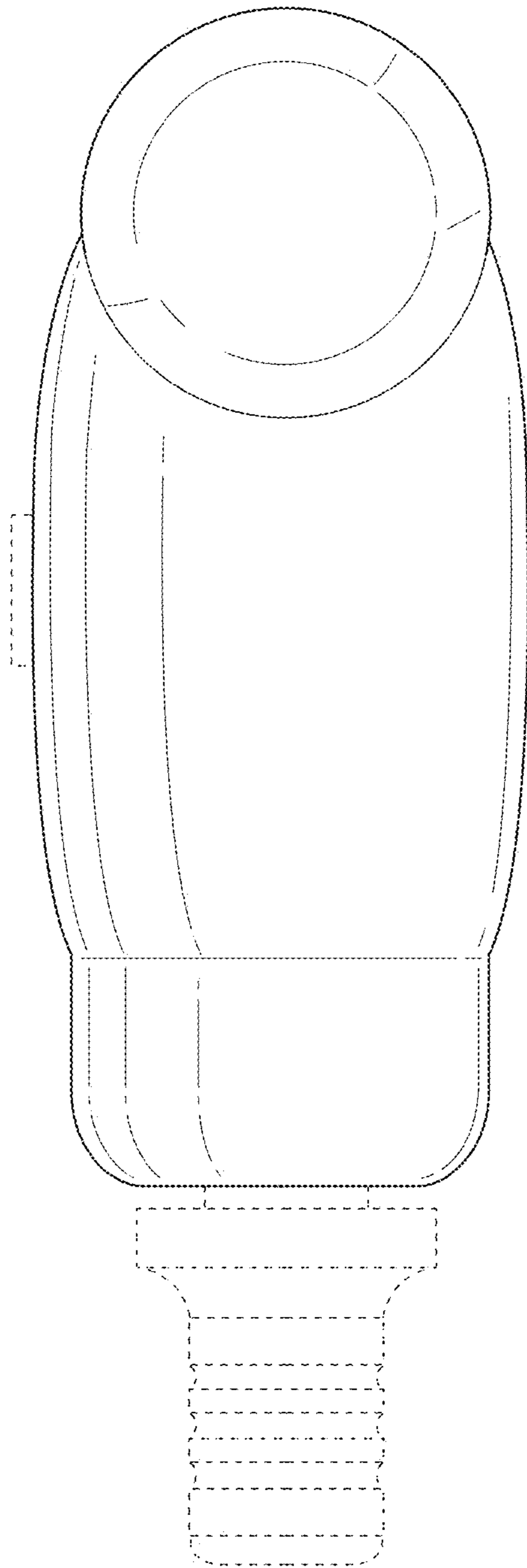

FIG. 6