



US00D884583S

(12) **United States Design Patent**
Speziari et al.

(10) **Patent No.:** **US D884,583 S**
(45) **Date of Patent:** **** May 19, 2020**

- (54) **TIRE FOR VEHICLE WHEELS**
- (71) Applicant: **Pirelli Tyre S.p.A.**, Milan (IT)
- (72) Inventors: **Diego Speziari**, Milan (IT); **Vito Bello**, Milan (IT); **Stefano Montesello**, Milan (IT)
- (73) Assignee: **PIRELLI TYRE S.p.A.**, Milan (IT)
- (**) Term: **15 Years**
- (21) Appl. No.: **29/695,954**
- (22) Filed: **Jun. 24, 2019**

- D741,784 S * 10/2015 Son D12/531
- D756,893 S * 5/2016 Son D12/531
- D782,960 S * 4/2017 Tikka D12/531

* cited by examiner

Primary Examiner — Lakiya G Rogers

Assistant Examiner — John A Voytek

(74) *Attorney, Agent, or Firm* — Finnegan, Henderson, Farabow, Garrett & Dunner, L.L.P.

(57) **CLAIM**

The ornamental design for a tire for vehicle wheels, as shown and described.

DESCRIPTION

FIG. 1 is a left, perspective view of a first embodiment of a tire for vehicle wheels, showing our new design;
 FIG. 2 is a right side elevation view thereof;
 FIG. 3 is a front elevation view thereof, it being understood that the tread pattern is repeated throughout the circumference of the tire;
 FIG. 4 is an enlarged front elevation view of FIG. 3, showing a portion thereof;
 FIG. 5 is a left side elevation view of the tire;
 FIG. 6 is a left, perspective view of a second embodiment of a tire for vehicle wheels, showing our new design;
 FIG. 7 is a right side elevation view thereof;
 FIG. 8 is a front elevation view thereof, it being understood that the tread pattern is repeated throughout the circumference of the tire;
 FIG. 9 is an enlarged front elevation view of FIG. 8, showing a portion thereof; and,
 FIG. 10 is a left side elevation view of the tire.

The portions of the tire for vehicle wheels depicted in broken dashed lines of uneven length mark the boundaries of the claimed design. The portions of the tire for vehicle wheels depicted in broken dashed lines of even length form no part of the claimed design.

1 Claim, 10 Drawing Sheets

Related U.S. Application Data

- (62) Division of application No. 29/636,324, filed on Feb. 7, 2018.

(30) **Foreign Application Priority Data**

Aug. 7, 2017 (EM) 004137362

- (51) **LOC (12) Cl.** **12-15**

- (52) **U.S. Cl.**
USPC **D12/532**

(58) **Field of Classification Search**

USPC D12/500–532, 604
 CPC Y10T 152/10027; B60C 1/0016; B60C 11/0306; B60C 11/0302; B60C 3/06; B60C 9/17

See application file for complete search history.

(56) **References Cited**

U.S. PATENT DOCUMENTS

- D526,270 S * 8/2006 Miyasaka D12/532
- D608,271 S * 1/2010 Woidtke D12/531
- D656,084 S * 3/2012 Jacobs D12/527
- D682,774 S * 5/2013 Nagayasu D12/531
- D725,585 S * 3/2015 Brandau D12/531

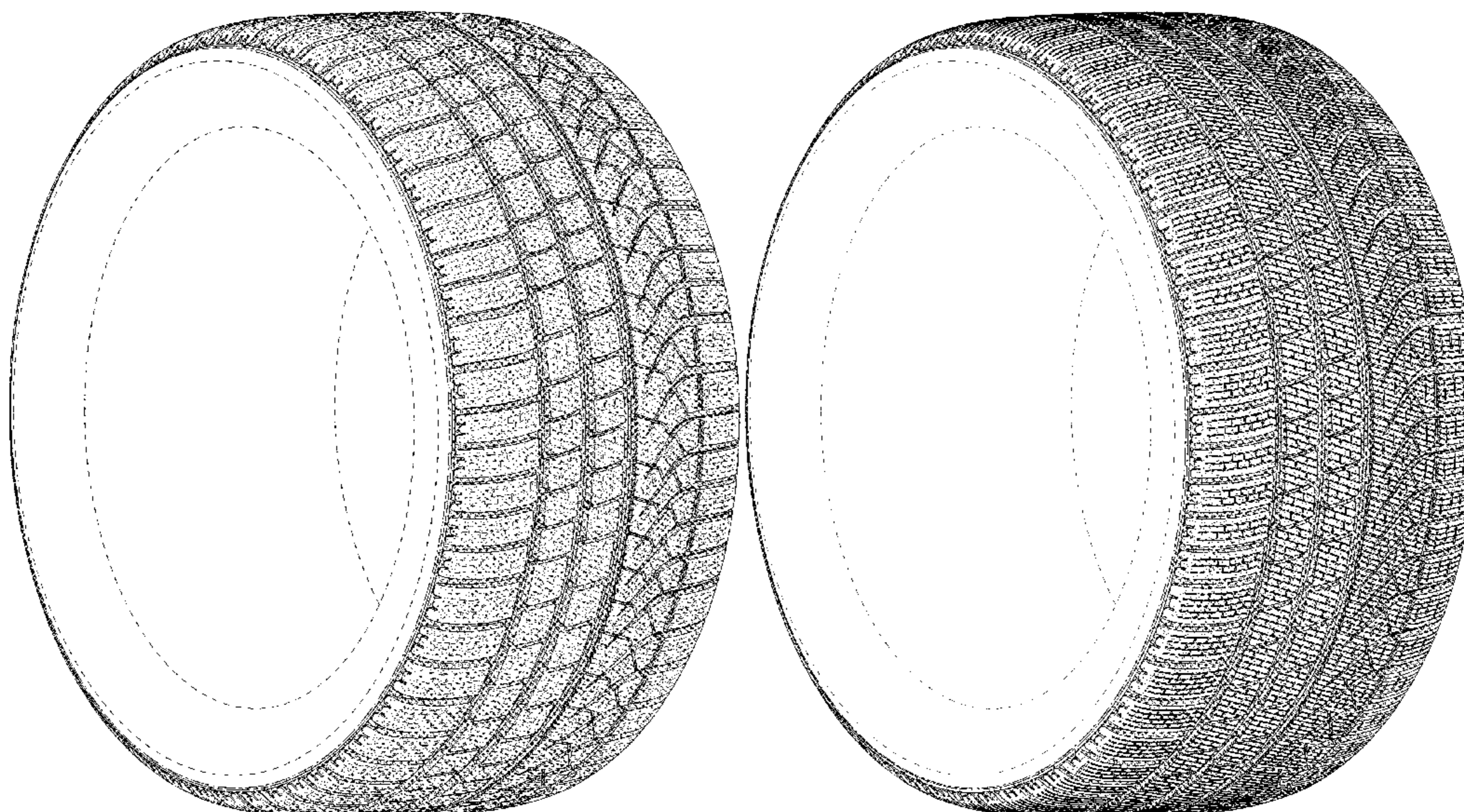

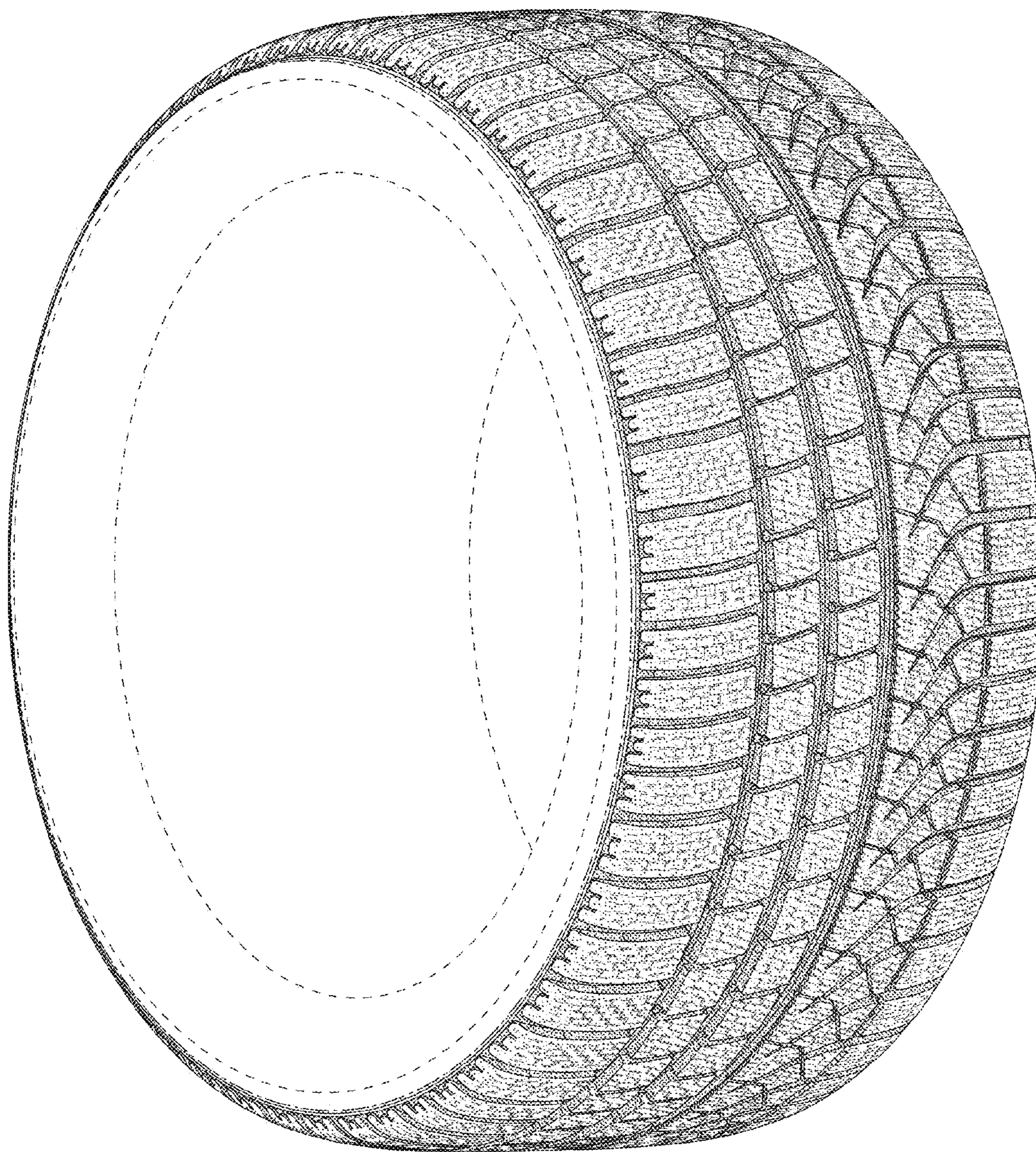

FIG. 1

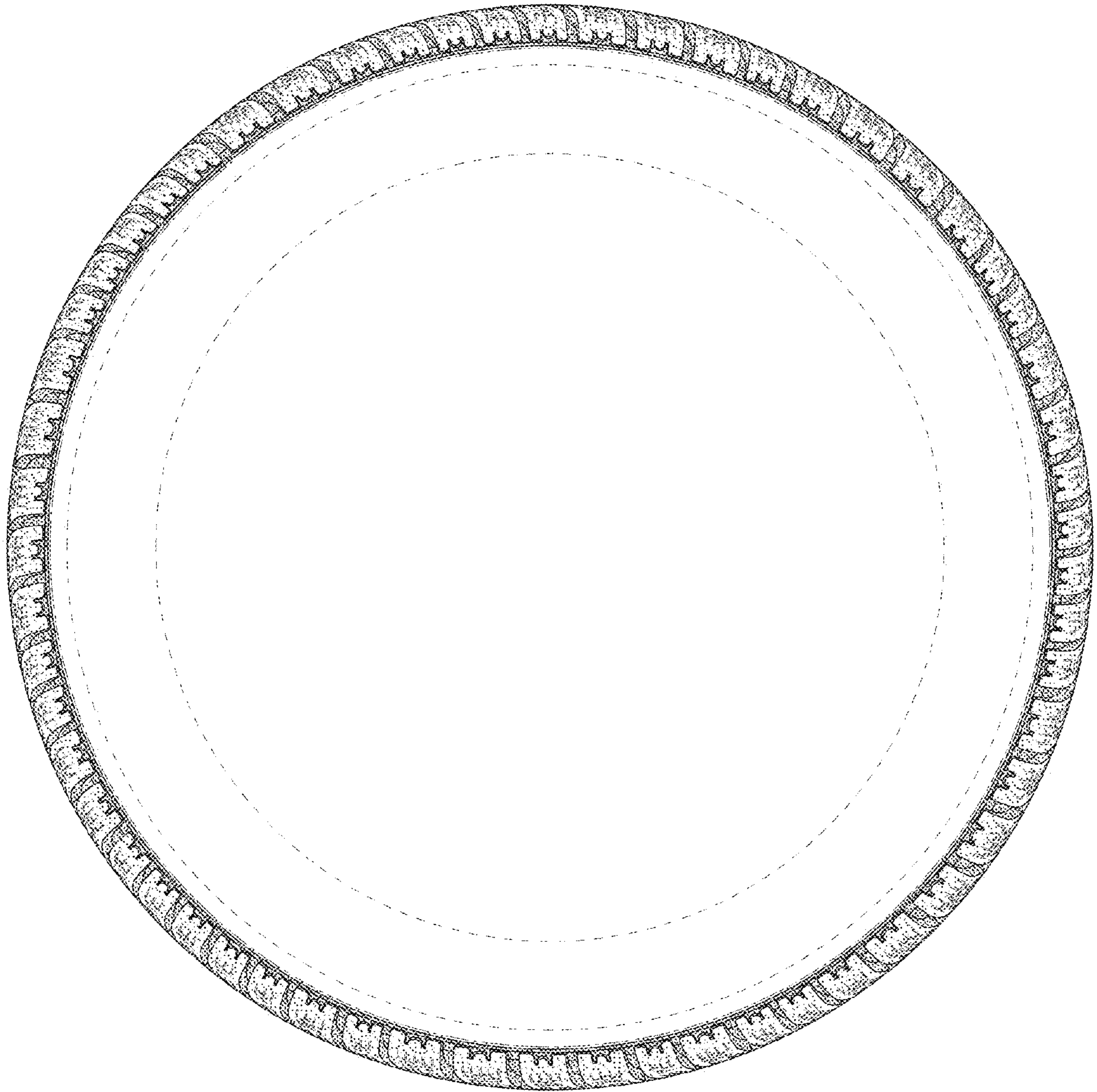

FIG. 2

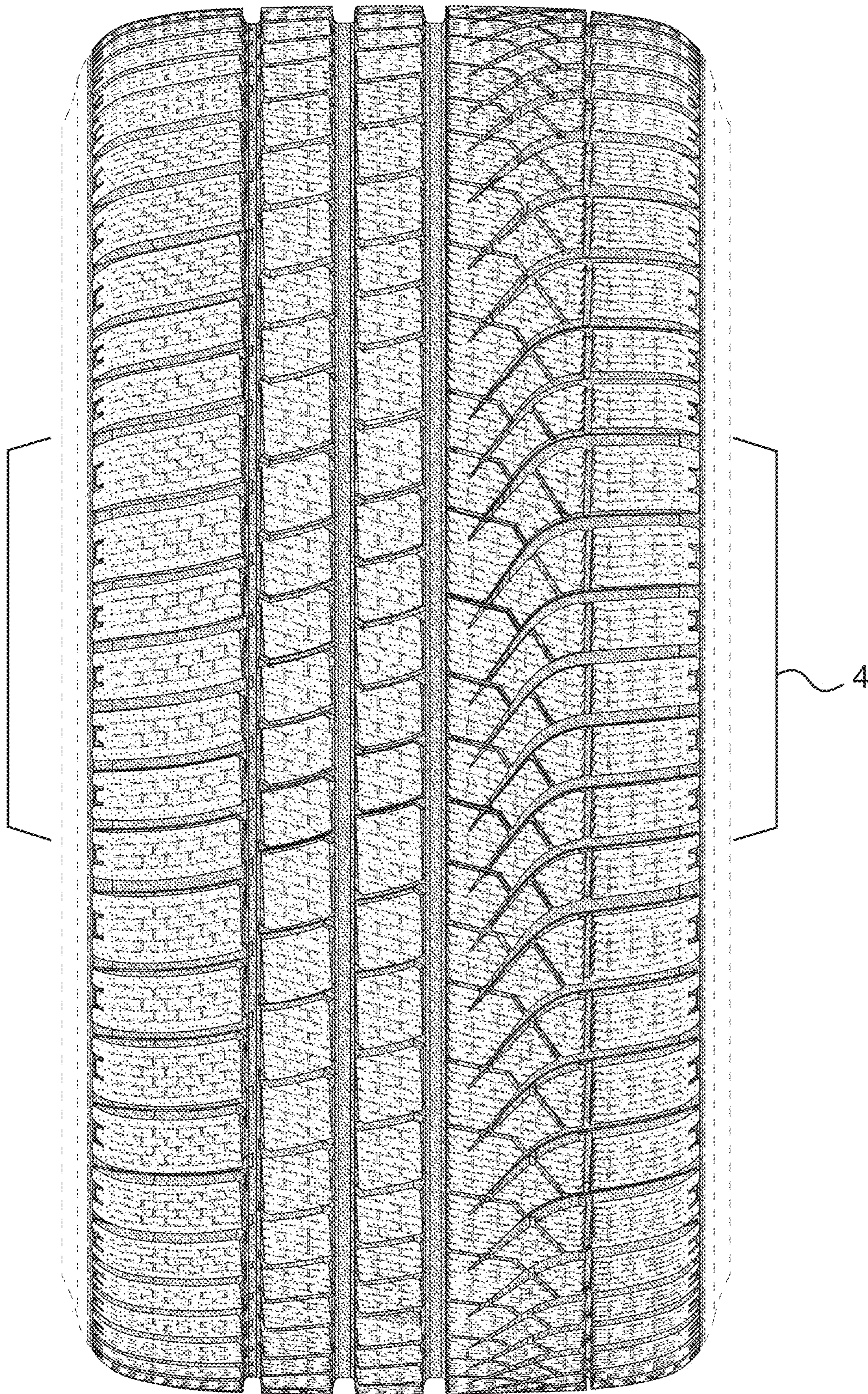

FIG. 3

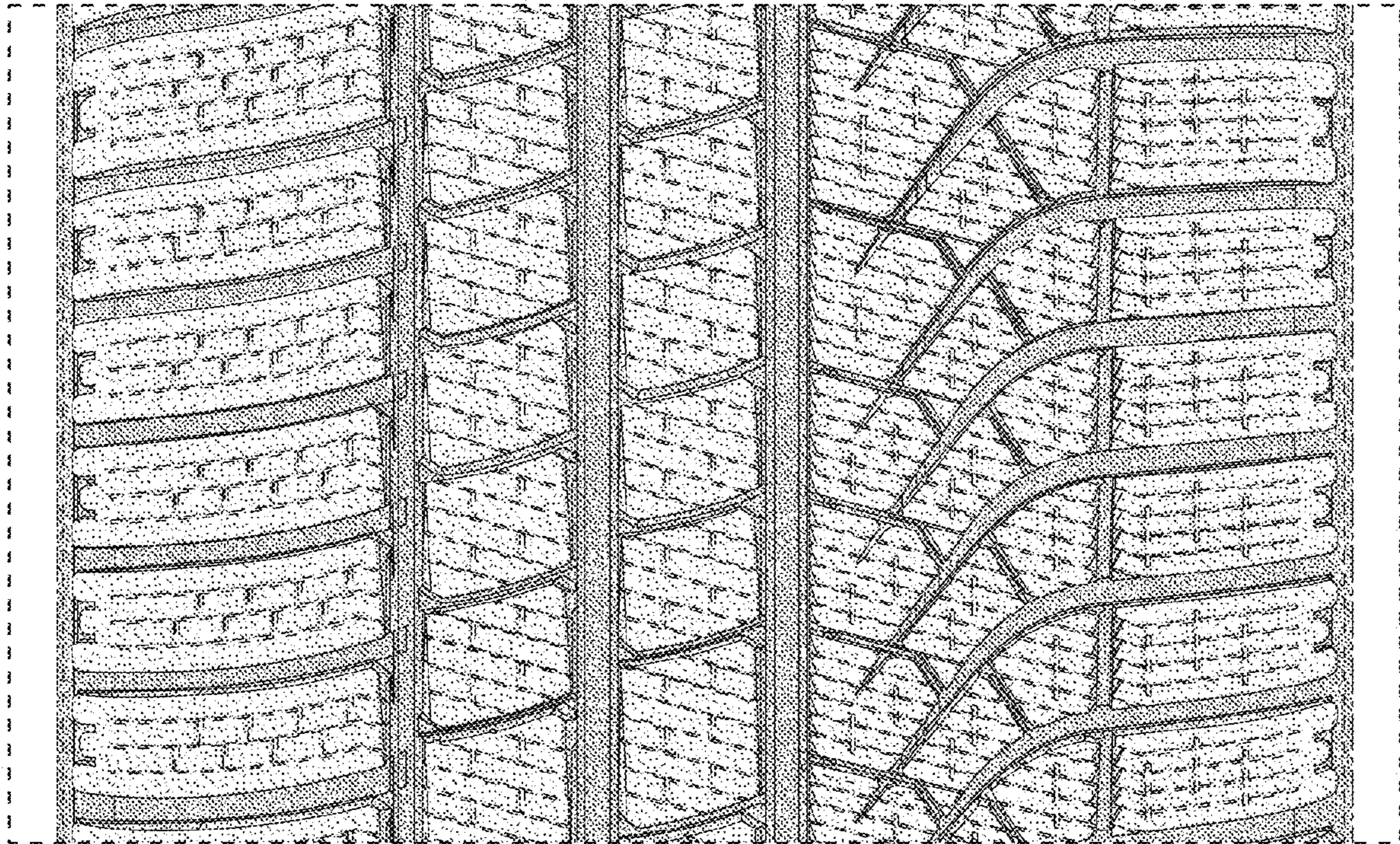

FIG. 4

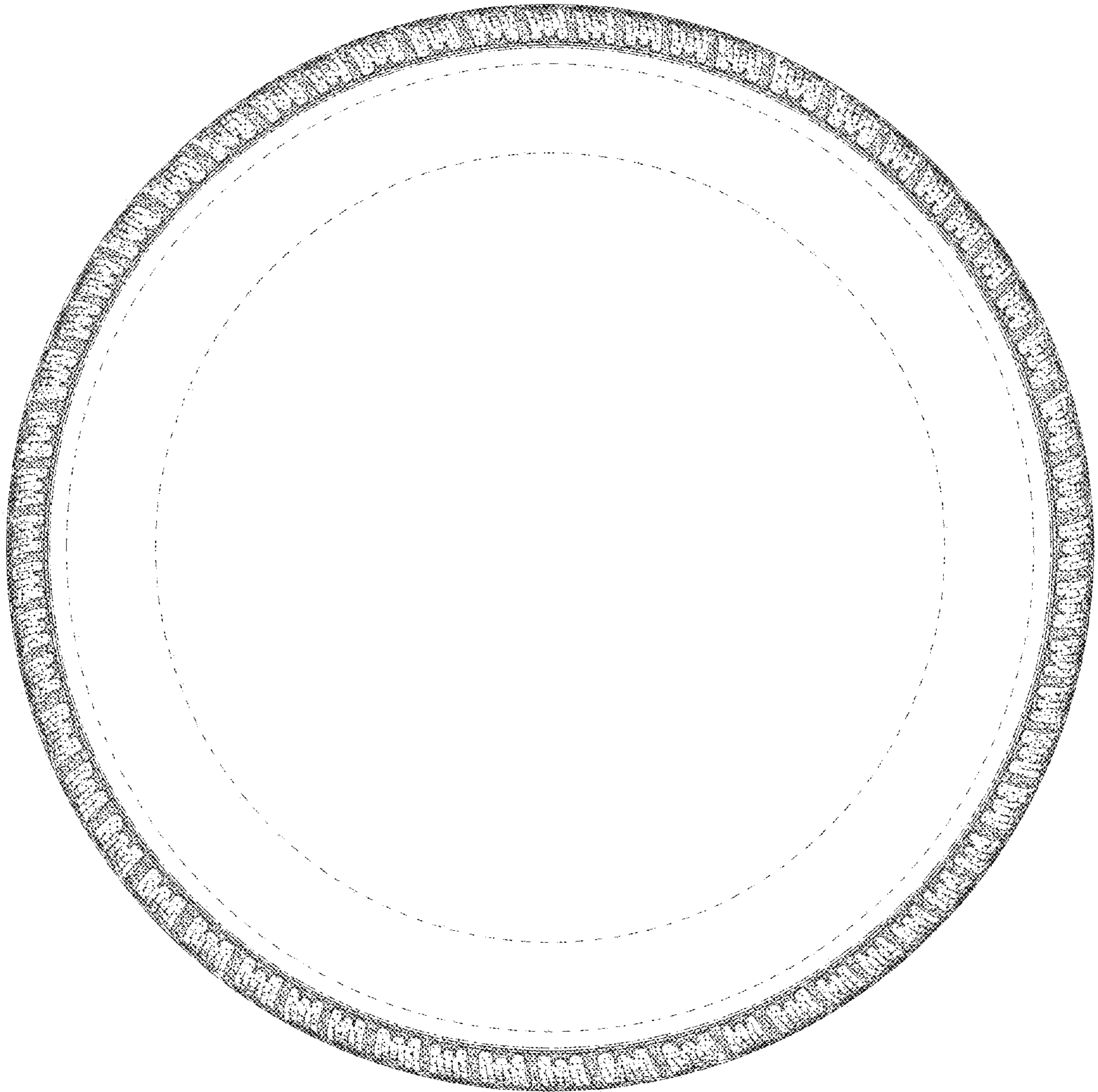

FIG. 5

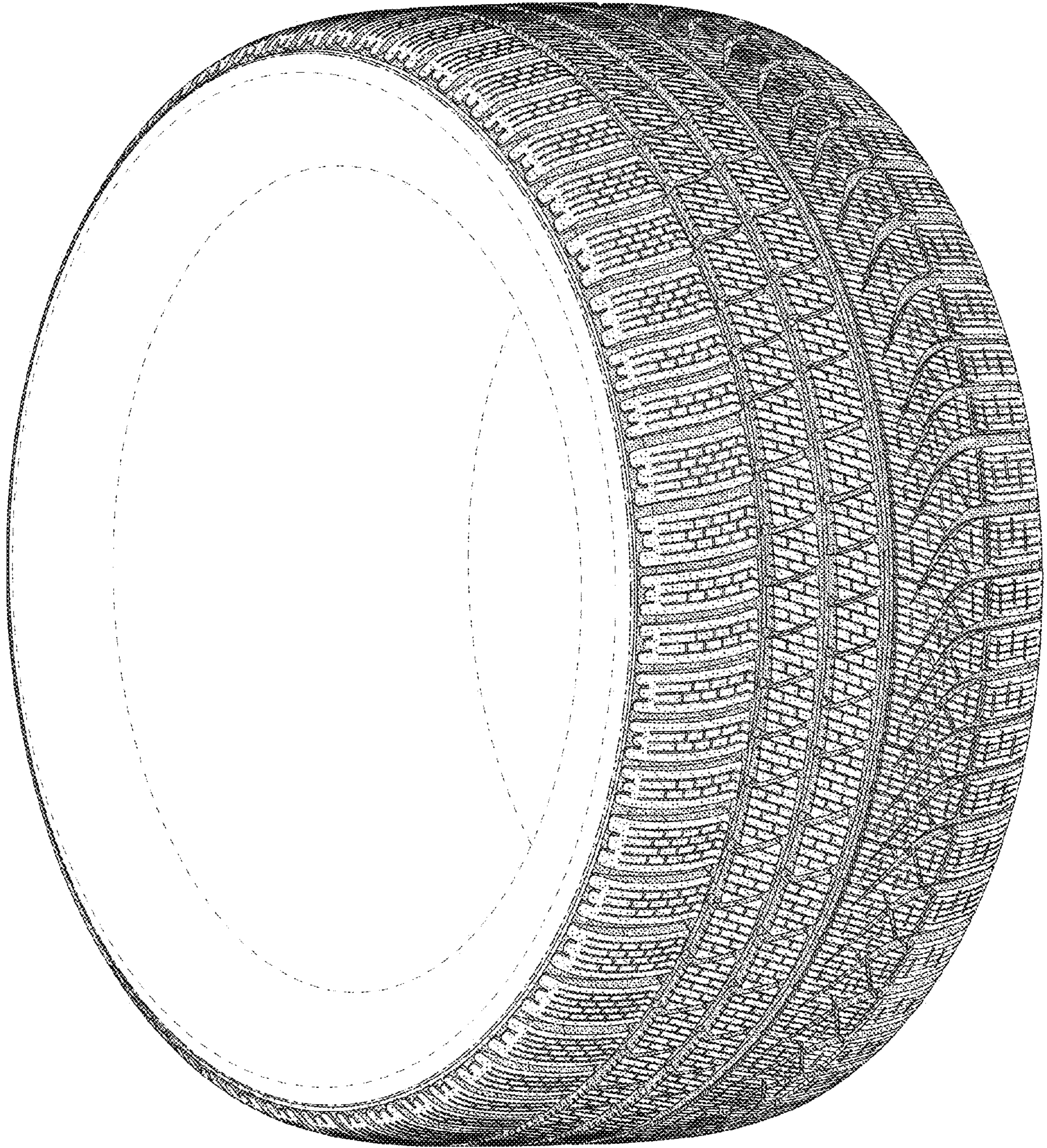

FIG. 6

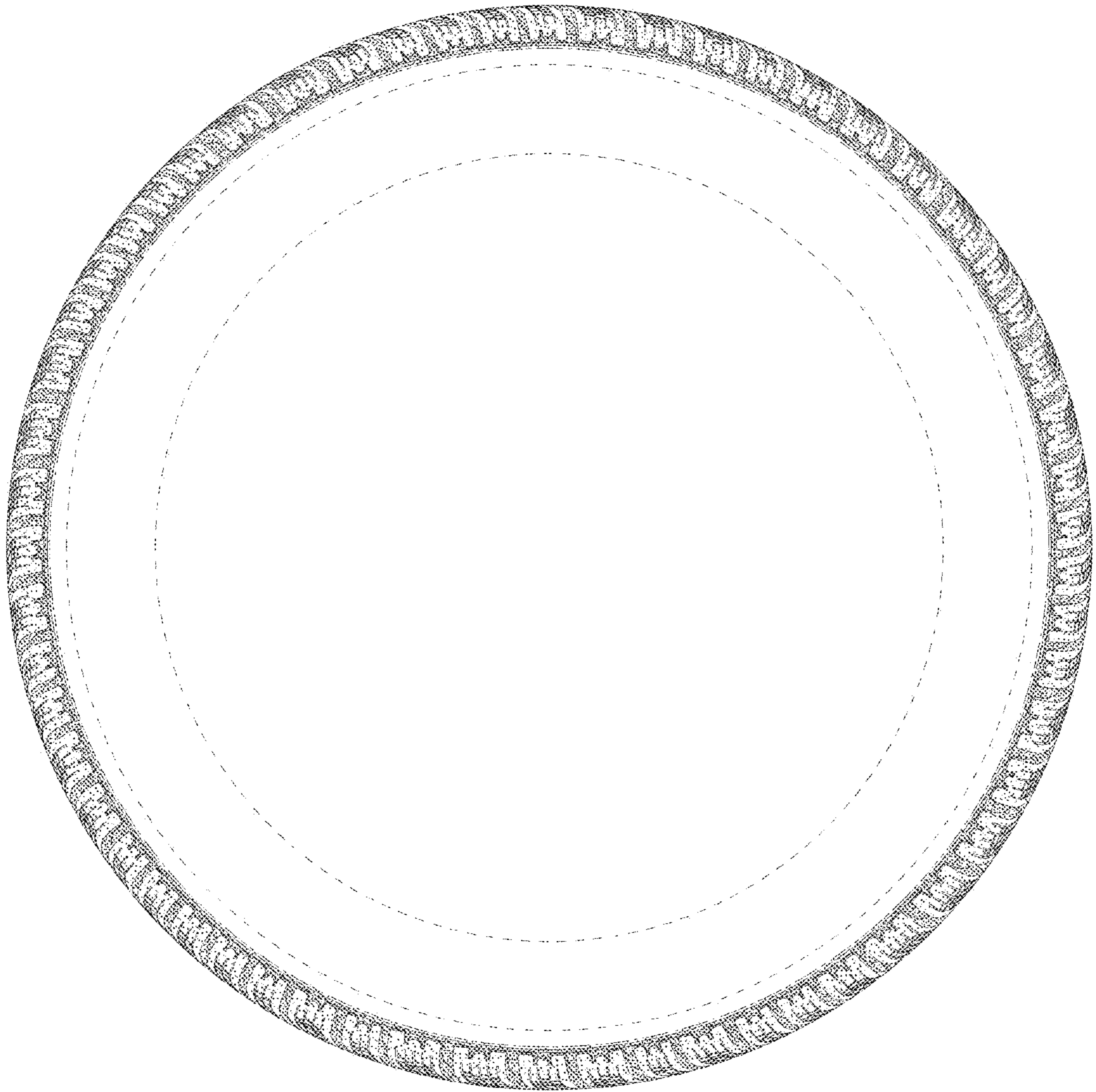

FIG. 7

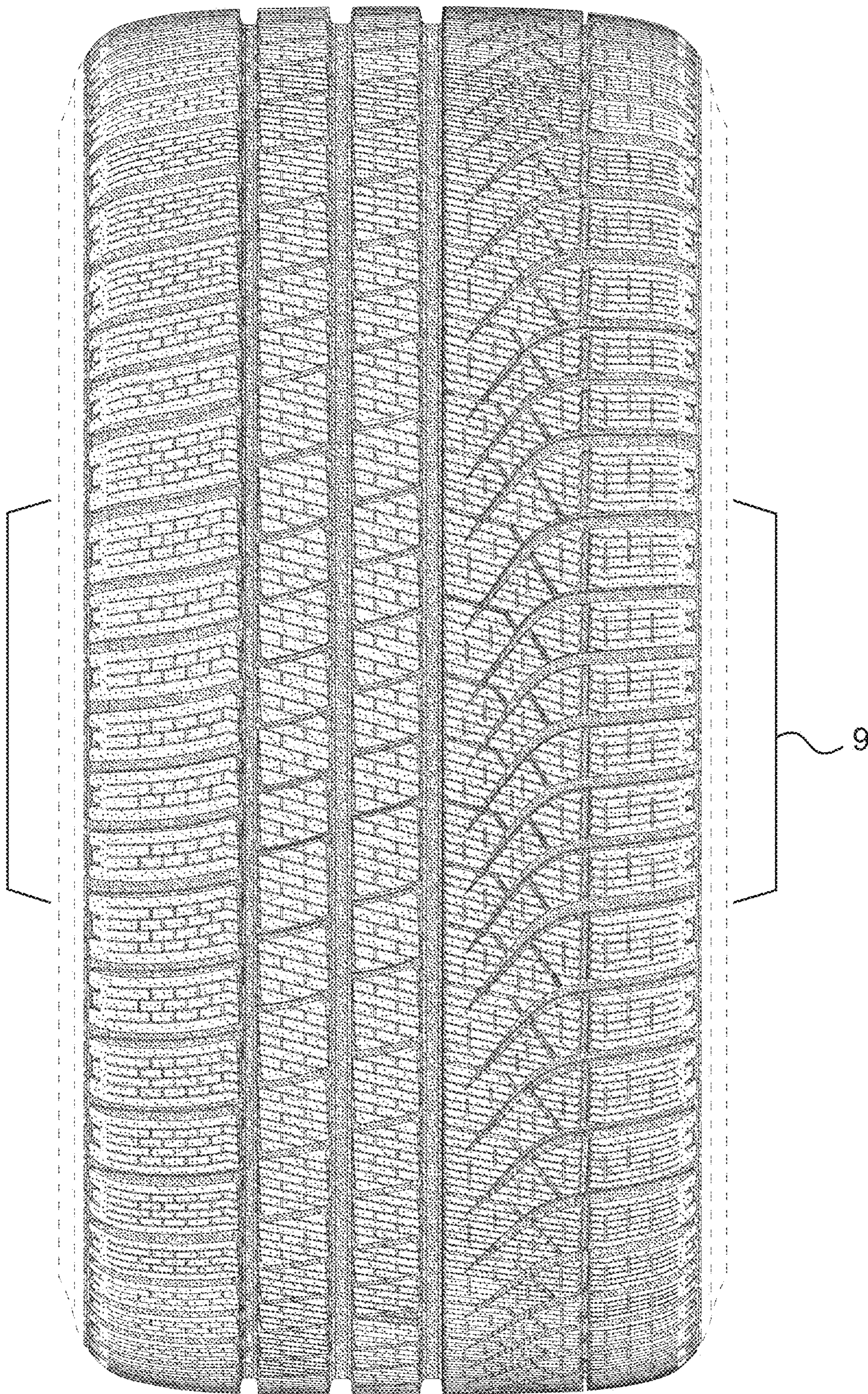

FIG. 8

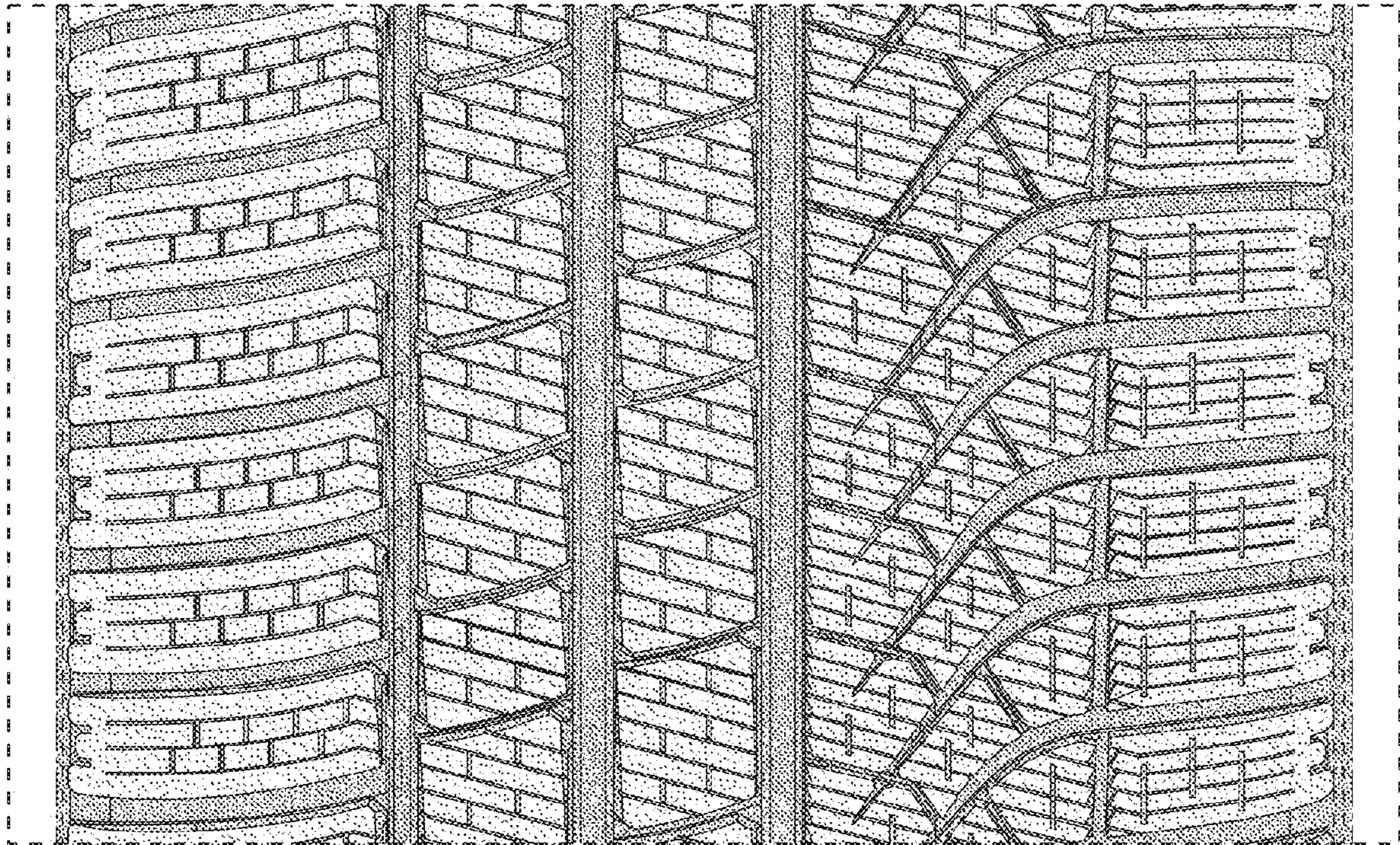

FIG. 9

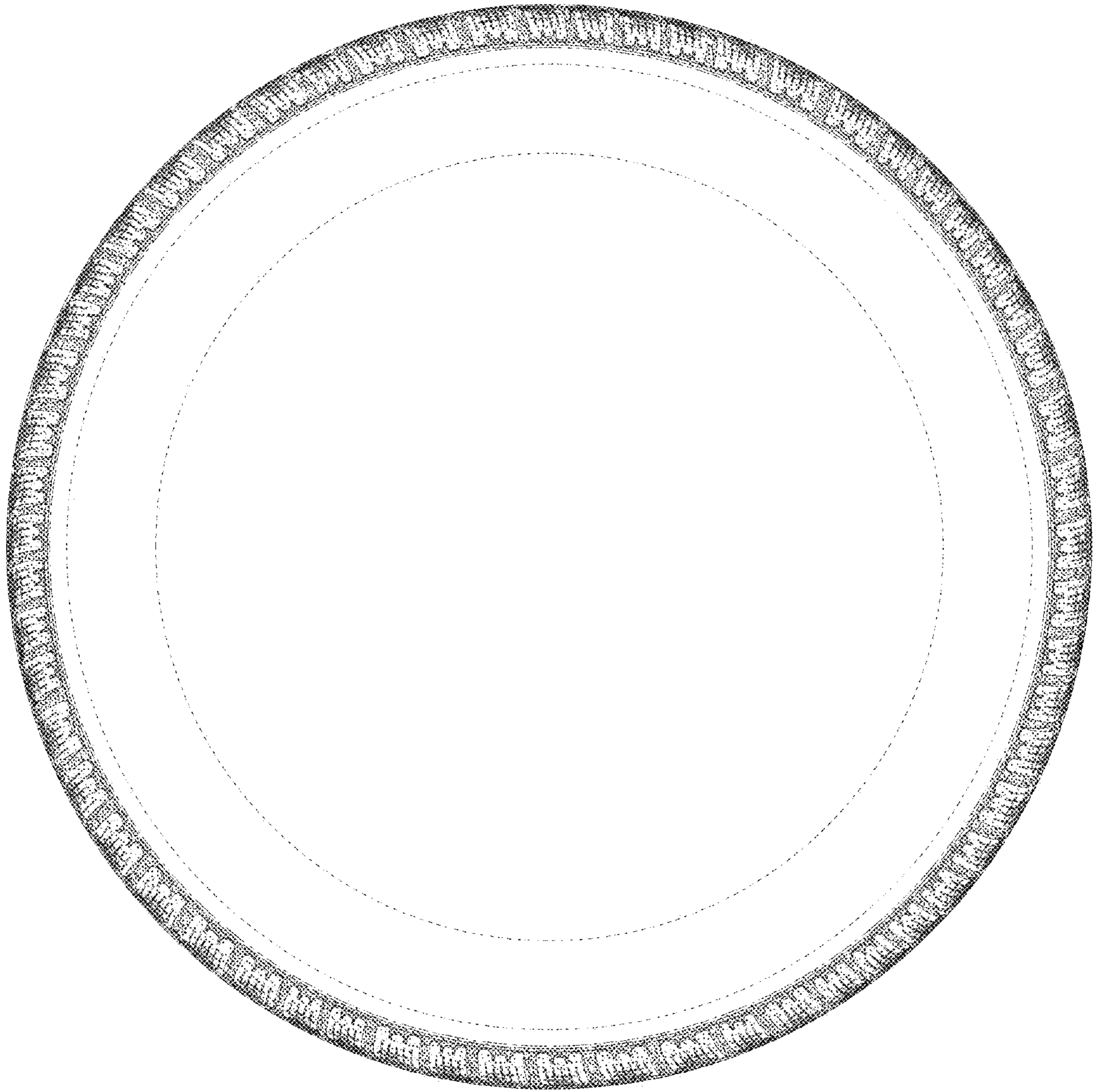

FIG. 10