



US00D884566S

(12) **United States Design Patent** (10) **Patent No.:** **US D884,566 S**  
**Hirneise** (45) **Date of Patent:** **\*\* May 19, 2020**

(54) **VEHICLE ACCELERATOR PEDAL EXTENSION**  
(71) Applicant: **Paul Hirneise**, Gainesville, FL (US)  
(72) Inventor: **Paul Hirneise**, Gainesville, FL (US)  
(\*\*) Term: **15 Years**  
(21) Appl. No.: **29/689,229**  
(22) Filed: **Apr. 29, 2019**  
(51) **LOC (12) Cl.** ..... **12-16**  
(52) **U.S. Cl.**  
USPC ..... **D12/174**  
(58) **Field of Classification Search**  
USPC ..... D12/125, 203, 174, 400; D13/167  
CPC . G05G 1/38; G05G 1/487; G05G 1/60; G10C  
3/26; B60T 7/06; B60N 3/044; B60K  
26/02  
See application file for complete search history.

D208,403 S \* 8/1967 Bisanar ..... D12/174  
D210,361 S \* 3/1968 Clark ..... D12/174  
4,984,838 A \* 1/1991 Kim ..... B60N 3/044  
296/75  
6,131,485 A \* 10/2000 Raja ..... G05G 1/487  
180/334  
D444,435 S \* 7/2001 Saleen ..... D12/174  
6,370,984 B1 \* 4/2002 Chang ..... B60T 7/06  
74/563  
D540,227 S \* 4/2007 Doucet ..... D12/174  
D570,764 S \* 6/2008 Thomaz ..... D12/174  
D669,404 S \* 10/2012 Bondra ..... D12/174  
9,898,031 B1 \* 2/2018 Wurzer ..... G05G 1/487  
2012/0137824 A1 \* 6/2012 Himanen ..... G05G 1/38  
74/560

\* cited by examiner

*Primary Examiner* — Susan E Krakower  
*Assistant Examiner* — Jerry Shiuan-Hua Hsu  
(74) *Attorney, Agent, or Firm* — Sven W Hanson

(57) **CLAIM**

The ornamental design for a vehicle accelerator pedal extension, as shown and described.

(56) **References Cited**

U.S. PATENT DOCUMENTS

1,445,355 A \* 2/1923 Reichert ..... G05G 1/487  
74/563  
1,981,148 A \* 11/1934 Muench ..... G05G 1/60  
74/564  
D148,485 S \* 1/1948 Rowe ..... D13/167  
2,518,056 A \* 8/1950 Olsen ..... G05G 1/487  
74/478.5  
2,536,903 A \* 1/1951 Benedict ..... G10C 3/26  
84/230  
2,609,705 A \* 9/1952 Fletcher, Sr. .... G05G 1/487  
74/562.5  
2,996,931 A \* 8/1961 Garafola ..... B60K 26/02  
74/562  
3,047,088 A \* 7/1962 Murrell ..... G05G 1/60  
180/90.6

**DESCRIPTION**

FIG. 1 is a perspective of a vehicle accelerator pedal extension illustrating my new design. FIG. 2 is a front elevation view thereof. FIG. 3 is a back elevation view thereof. FIG. 4 is a right side view thereof. FIG. 5 is a left side view thereof. FIG. 6 is a top plan view thereof; and, FIG. 7 is a bottom plan view thereof. The broken lines illustrate portions of the vehicle accelerator pedal extension that form no part of the claimed design.

**1 Claim, 6 Drawing Sheets**

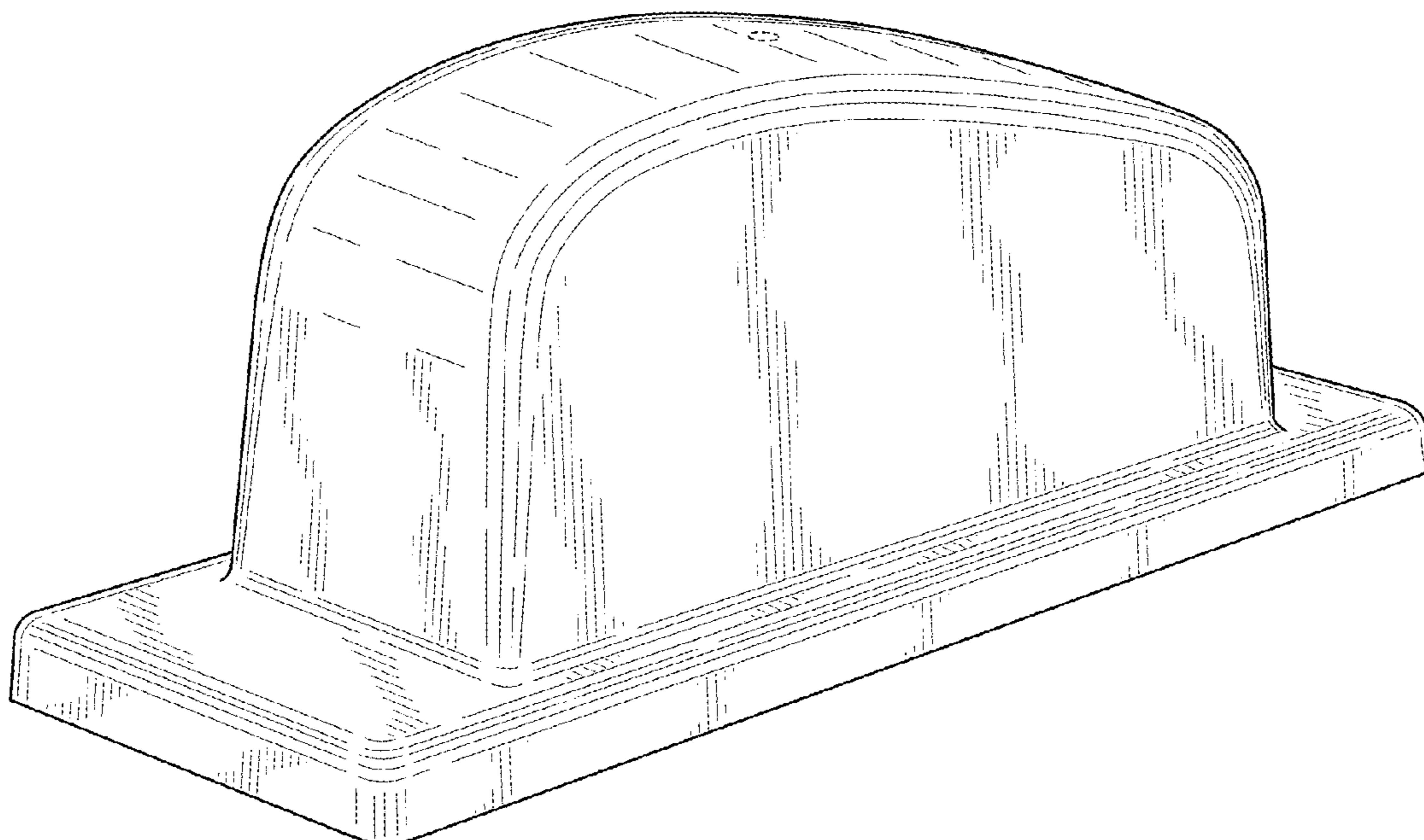

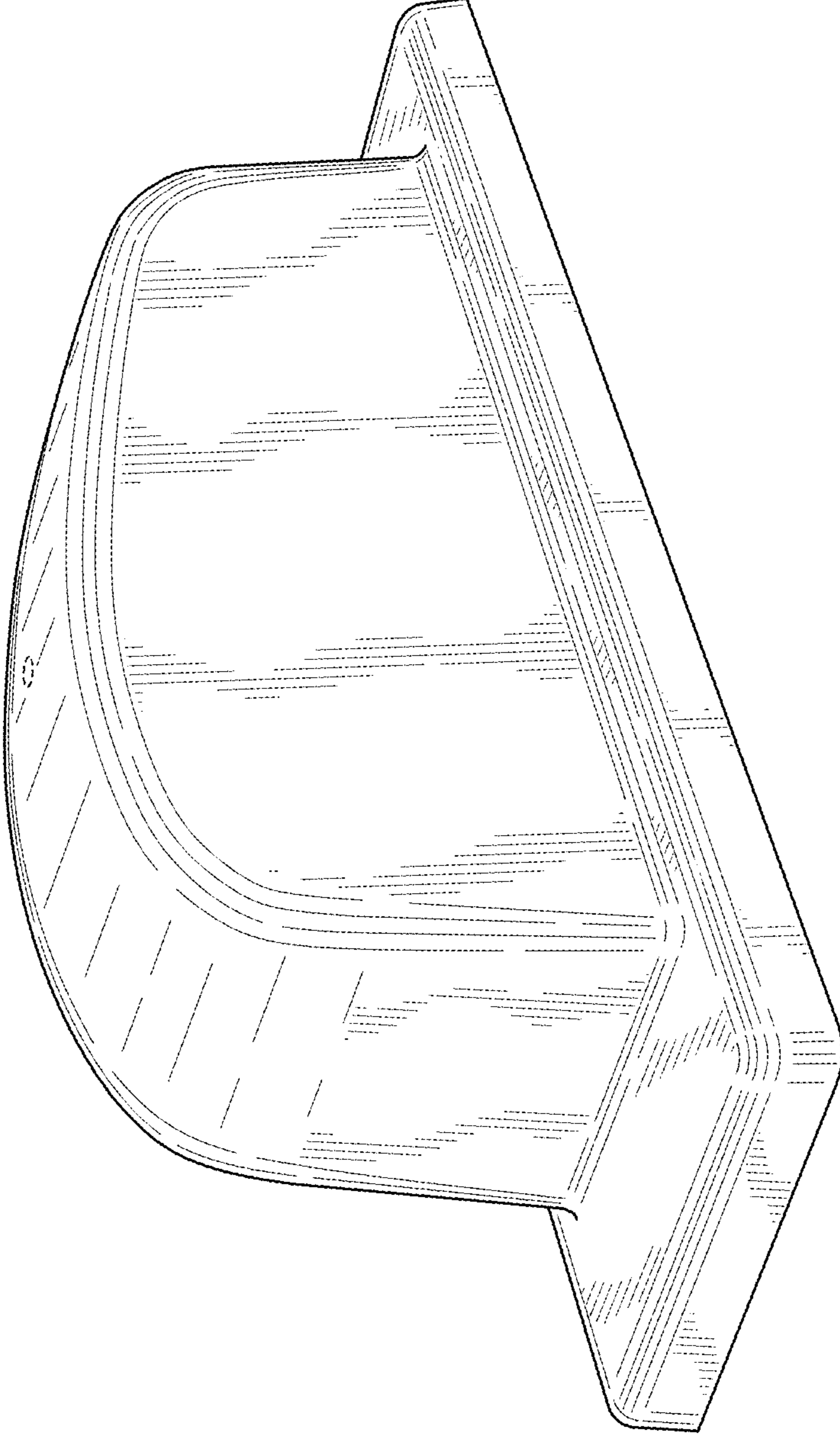

FIG. 1

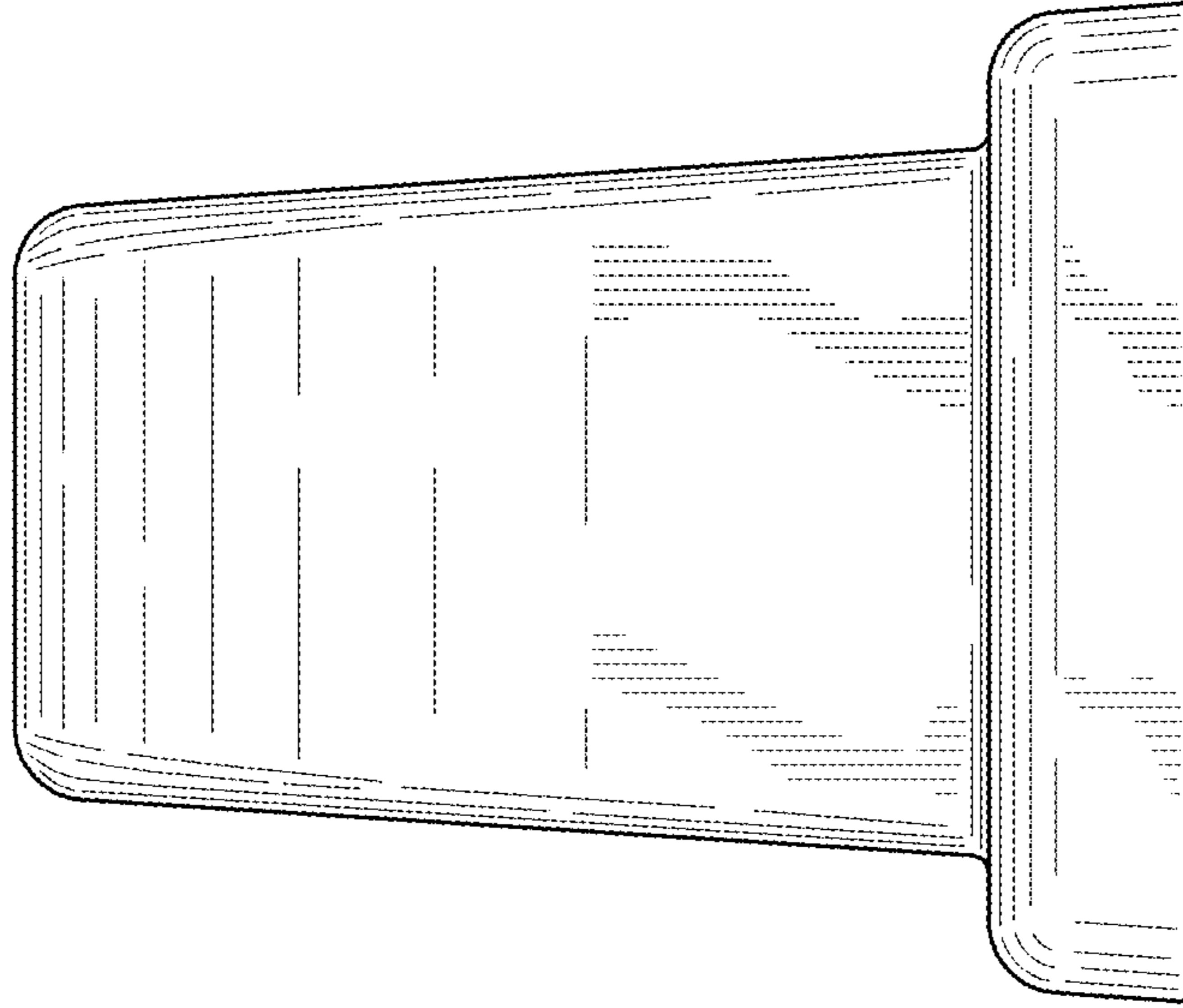

FIG. 3

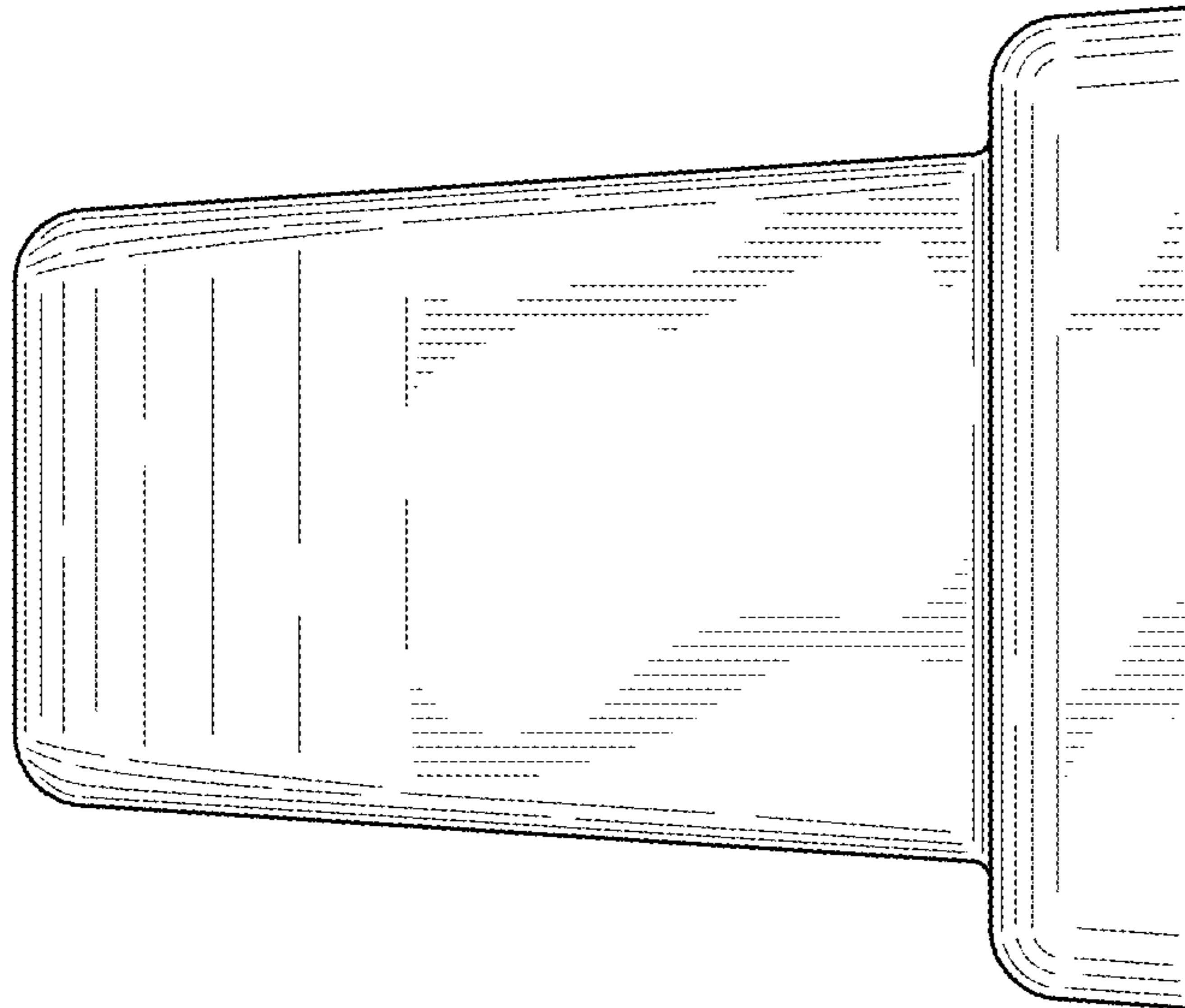

FIG. 2

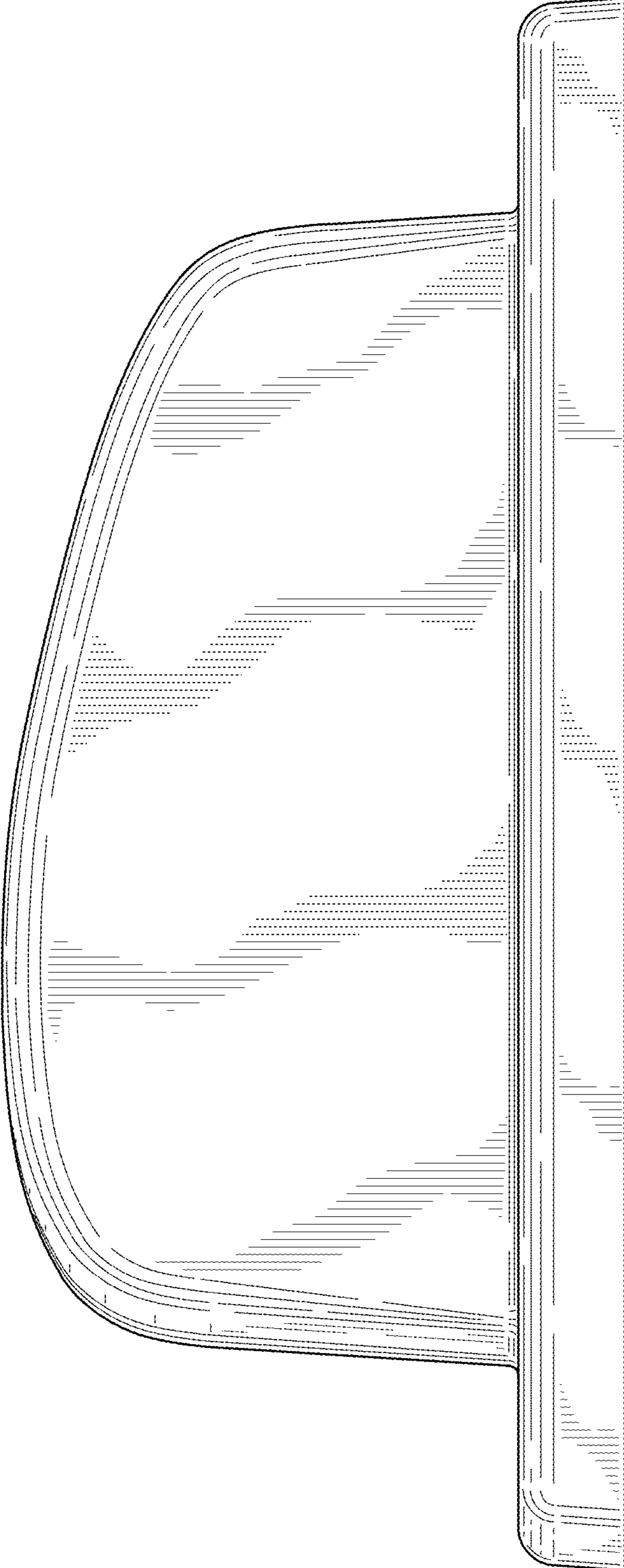

FIG. 4

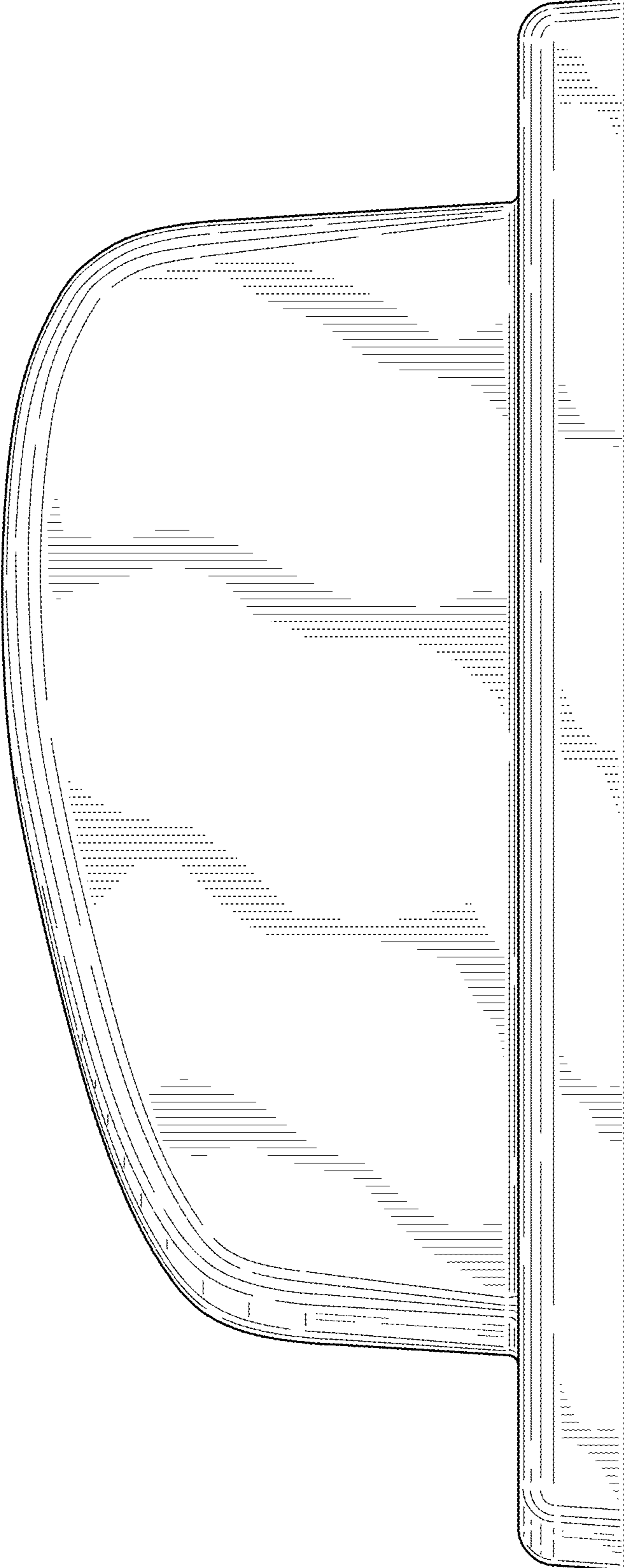

FIG. 5

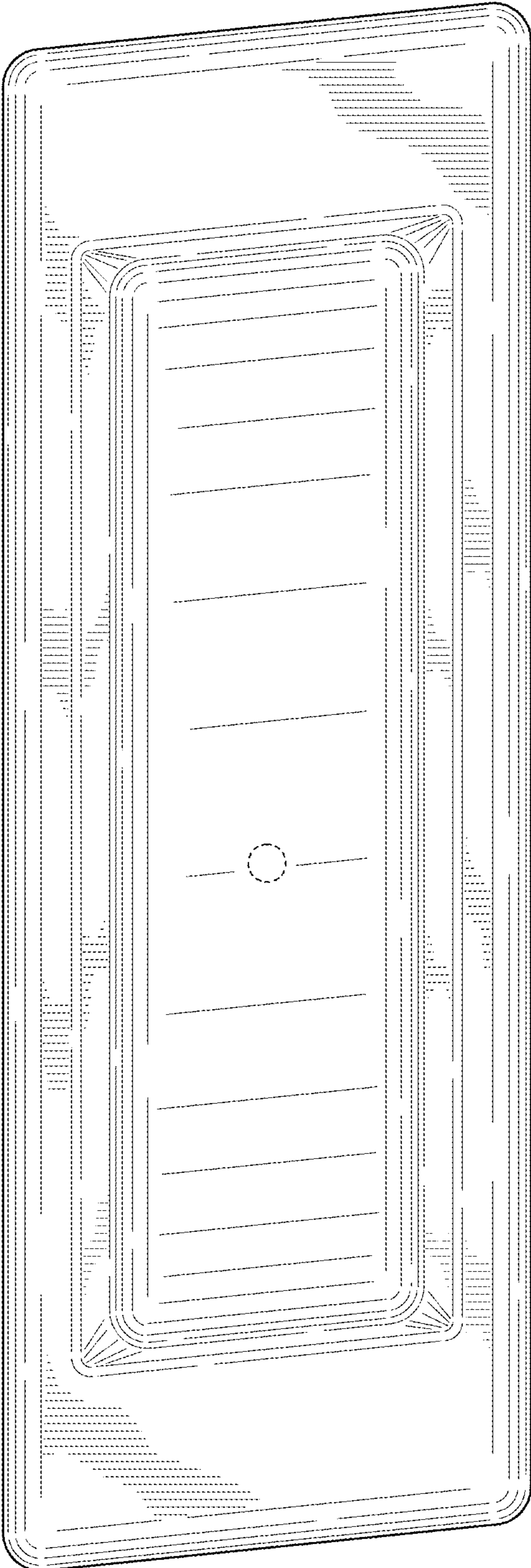

FIG. 6

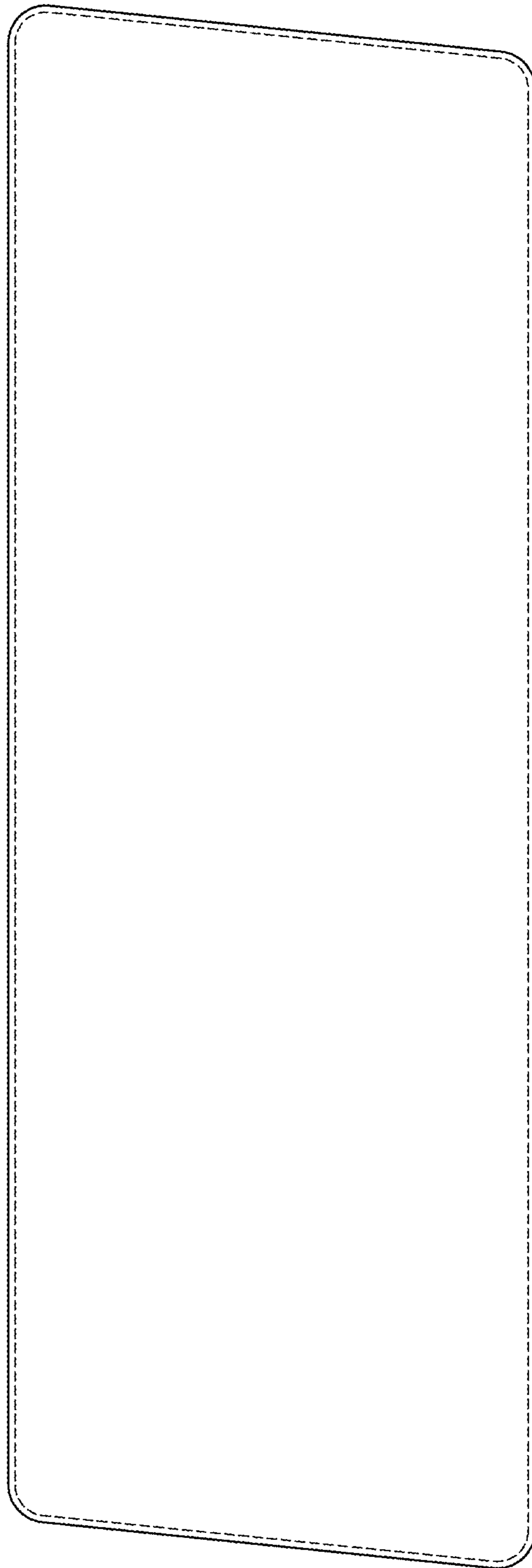

FIG. 7