



US00D884217S

(12) **United States Design Patent** (10) **Patent No.:** **US D884,217 S**
Martin et al. (45) **Date of Patent:** **** May 12, 2020**

(54) **MODULAR COMPOSITE SHELTER SYSTEM PANEL**

(71) Applicant: **Strategic Solutions Unlimited, Inc.**, Fayetteville, NC (US)

(72) Inventors: **Tony Michael Martin**, Myrtle Beach, SC (US); **Erik David Ross**, Fayetteville, NC (US)

(73) Assignee: **Strategic Solutions Unlimited, Inc.**, Fayetteville, NC (US)

(**) Term: **15 Years**

(21) Appl. No.: **29/684,893**

(22) Filed: **Mar. 25, 2019**

Related U.S. Application Data

(62) Division of application No. 29/580,172, filed on Oct. 6, 2016, now Pat. No. Des. 844,177.

(51) **LOC (12) Cl.** **25-02**

(52) **U.S. Cl.**
USPC **D25/60**

(58) **Field of Classification Search**
USPC D25/33, 58, 60, 138
CPC .. E04B 31/0007; E04B 31/14; E04B 31/3445;
E04B 31/3483; E04B 31/34321; E04C
2/384; E04F 13/0826
See application file for complete search history.

(56) **References Cited**

U.S. PATENT DOCUMENTS

2,087,958	A *	7/1937	Allen	E04C 2/14 52/223.7
2,120,861	A	6/1938	Hastings		
2,647,287	A *	8/1953	Jones	E04B 1/6183 52/582.2
3,236,014	A	2/1966	Edgar		

(Continued)

OTHER PUBLICATIONS

MCSS-Sheet_Nov. 18 upload Apr. 2019 https://strategicsolutionsunlimited.com/wp-content/uploads/2019/04/MCSS-Sheet_Nov-18.pdf Uploaded Apr. 2019 (Year: 2019).*

(Continued)

Primary Examiner — Leanne Was-Englehart
(74) *Attorney, Agent, or Firm* — Dority & Manning, PA

(57) **CLAIM**

The ornamental design for a modular composite shelter system panel, as shown and described.

DESCRIPTION

FIG. 1 is an exterior perspective view of a modular composite shelter system panel including rabbet joint features; FIG. 2 is an interior perspective view of a modular composite shelter system panel including rabbet joint features; FIG. 3 is a detailed view of a portion of the modular composite shelter system panel of FIG. 1 as represented within circle 3; and, FIG. 4 is a detailed view of a portion of the modular composite shelter system panel of FIG. 2 as represented within circle 4.

The evenly spaced long-dash broken lines depict portions of the modular composite shelter system panel that form no part of the claimed design.

The drawings contain vertical and horizontal symbolic breaks in FIG. 1 and FIG. 2 depicted by the evenly spaced short-dash broken lines. The portion between the symbolic breaks forms no part of the claimed design.

The dot-dash broken lines in FIGS. 1 and 2 depict the limits of the enlarged views of FIGS. 3 and 4, respectively.

1 Claim, 3 Drawing Sheets

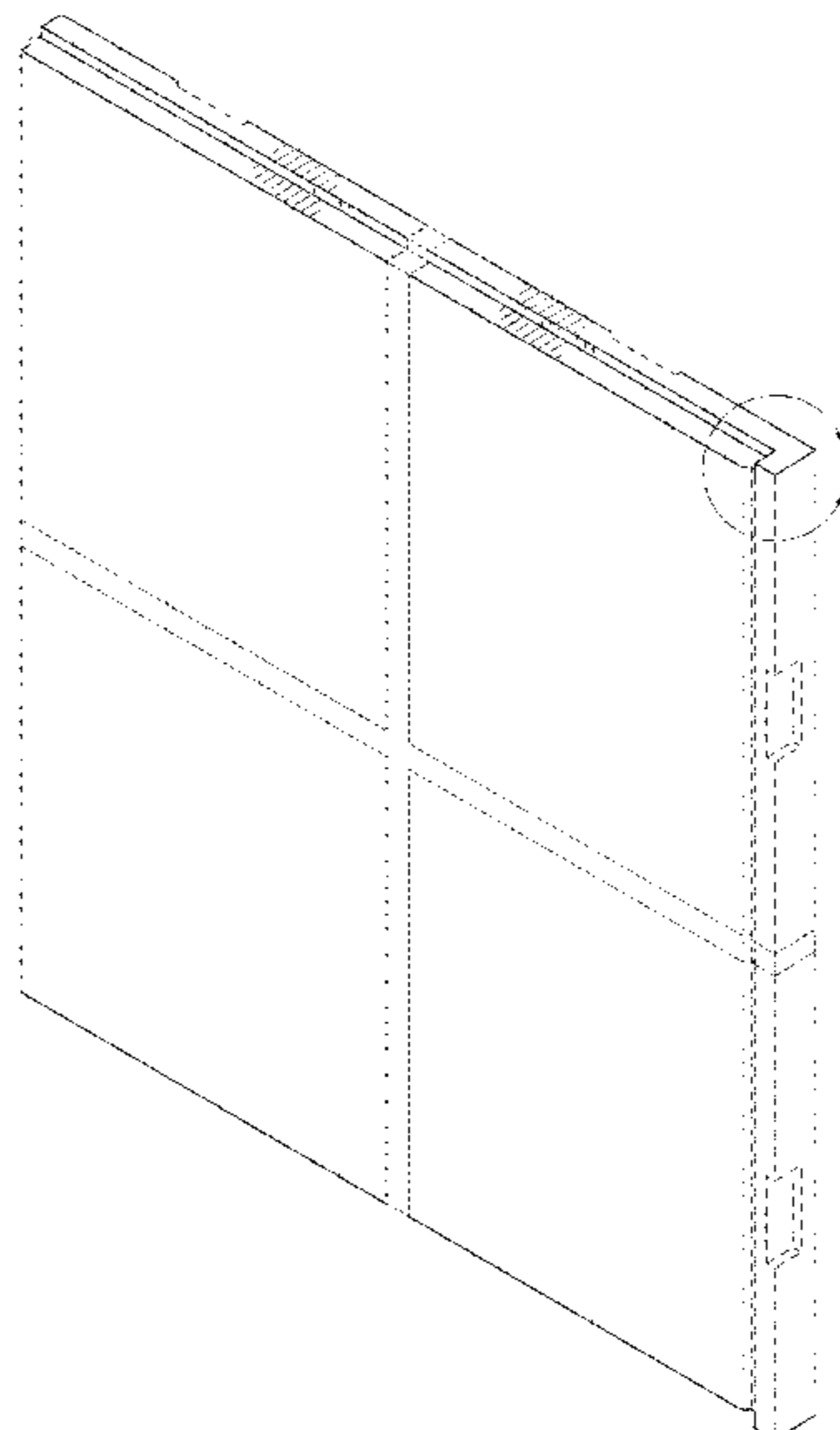

(56)

References Cited

U.S. PATENT DOCUMENTS

3,470,657 A * 10/1969 Irwin E04B 1/34315
52/27
3,500,606 A * 3/1970 Wharmby E04F 15/02188
52/591.1
3,509,673 A * 5/1970 Witkosky E04B 1/617
52/242
3,510,997 A * 5/1970 Ratych E04B 1/34823
52/79.2
3,611,667 A * 10/1971 Maxwell E04B 1/0007
52/747.1
3,729,889 A * 5/1973 Baruzzini E04B 1/6162
52/264
3,793,796 A * 2/1974 Hughes E04B 1/3483
52/79.8
3,992,828 A 11/1976 Ohe
4,018,020 A * 4/1977 Sauer E04B 2/7457
52/241
4,223,500 A 9/1980 Clark et al.
4,294,051 A * 10/1981 Hughes, Jr. E04B 1/14
52/223.7
4,599,829 A * 7/1986 DiMartino, Sr. E04B 1/3483
410/79
4,787,181 A * 11/1988 Witten E04B 1/3483
220/4.21
5,417,020 A * 5/1995 Dobija E04F 13/0826
52/235
6,179,522 B1 1/2001 Sanford et al.
D445,914 S * 7/2001 Helminiak D25/33
6,313,549 B1 11/2001 Moisan et al.
D479,883 S * 9/2003 Gresham D25/119
6,622,640 B2 9/2003 Taylor
D481,138 S * 10/2003 Forster A63C 19/10
D25/138

D481,466 S * 10/2003 Mueller D25/58
D496,737 S * 9/2004 Moon D25/33
D540,473 S * 4/2007 Loggen D25/58
D541,429 S * 4/2007 Horden D25/33
D593,215 S * 5/2009 Bohler D25/58
D610,266 S * 2/2010 Strehler D25/33
7,954,294 B2 6/2011 Appleford
D667,965 S * 9/2012 Tuan D25/138
D683,469 S 5/2013 Yoder et al.
8,646,242 B2 * 2/2014 Shapiro E04F 15/10
52/506.1
D722,395 S * 2/2015 Britton D25/138
D736,961 S * 8/2015 Geldart D25/138
D737,474 S * 8/2015 Geldart D25/138
D740,961 S 10/2015 Hart
D742,030 S 10/2015 Magiera
D754,368 S * 4/2016 Ohshima D25/138
D771,272 S 11/2016 Hart 1/5
D844,177 S * 3/2019 Martin D25/60
D858,796 S * 9/2019 Martin D25/33
2008/0263968 A1 10/2008 Day
2010/0043309 A1 2/2010 Martin et al.
2013/0067846 A1 3/2013 Kvols et al.
2014/0123572 A1 5/2014 Segall
2017/0314255 A1 * 11/2017 Klein E04B 1/3444
2017/0356182 A1 12/2017 Caffaratti Giro

OTHER PUBLICATIONS

Department of The Army, Appendix D (463L Cargo System),
“United Air Movement Planning”, Field Manual No. 55-9, Apr. 5,
1993. Washington, DC.
www.strategicsolutionsunlimited.com/modular-composite-shelter-system-mess/ Mar. 2017.
www.youtube.com/watch?v=eKL9VkPR4I posted Apr. 4, 2017.

* cited by examiner

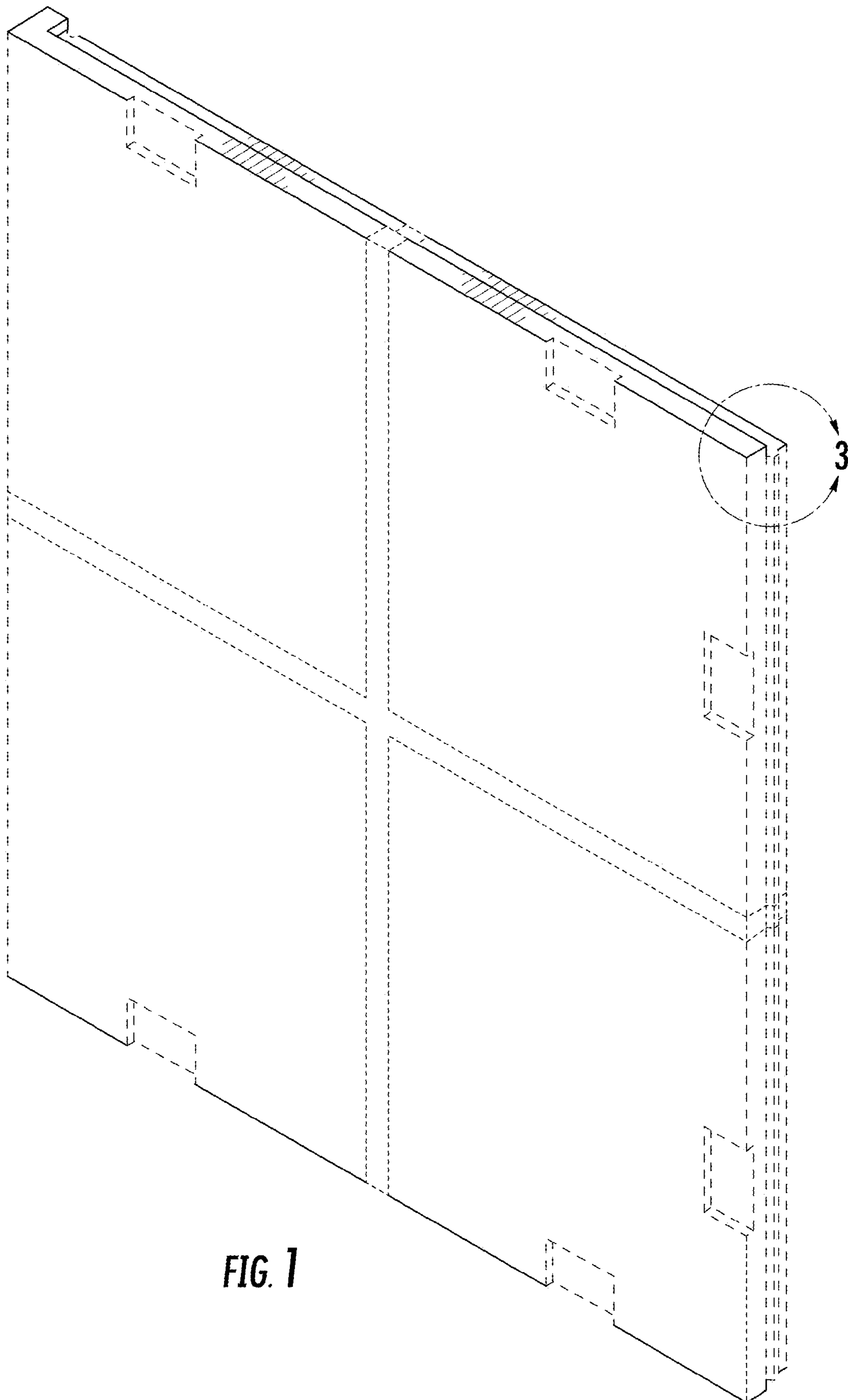

FIG. 1

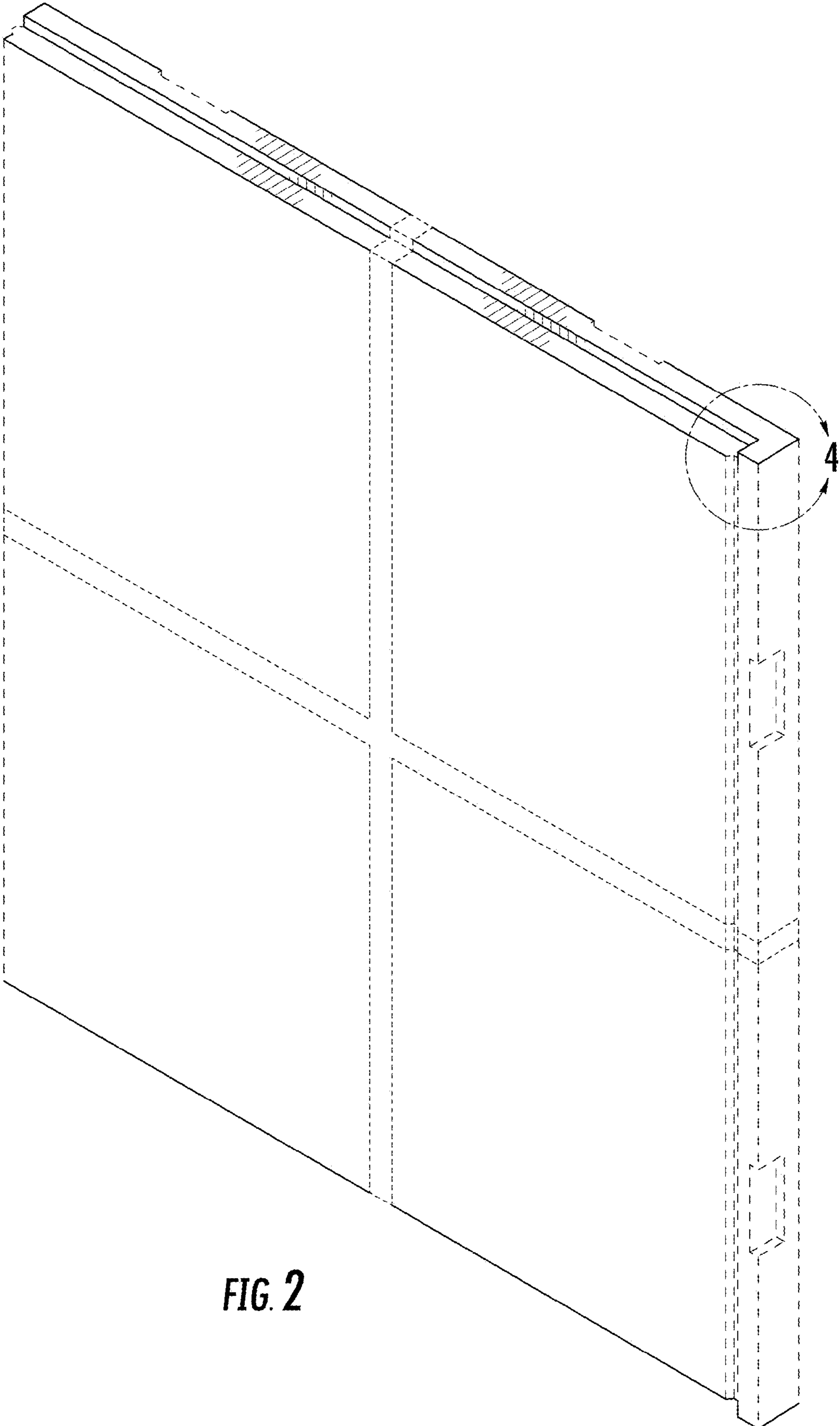

FIG. 2

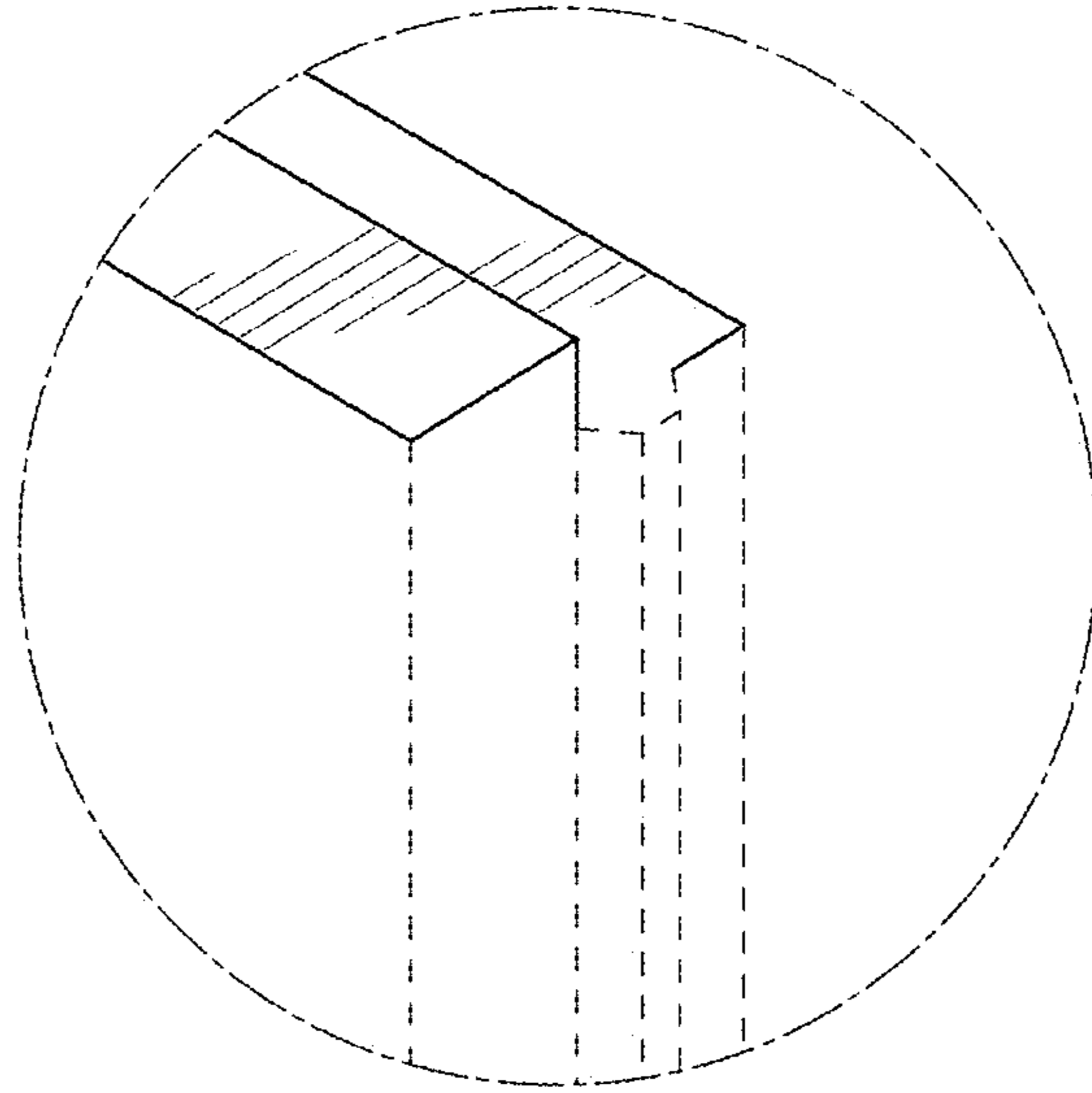

FIG. 3

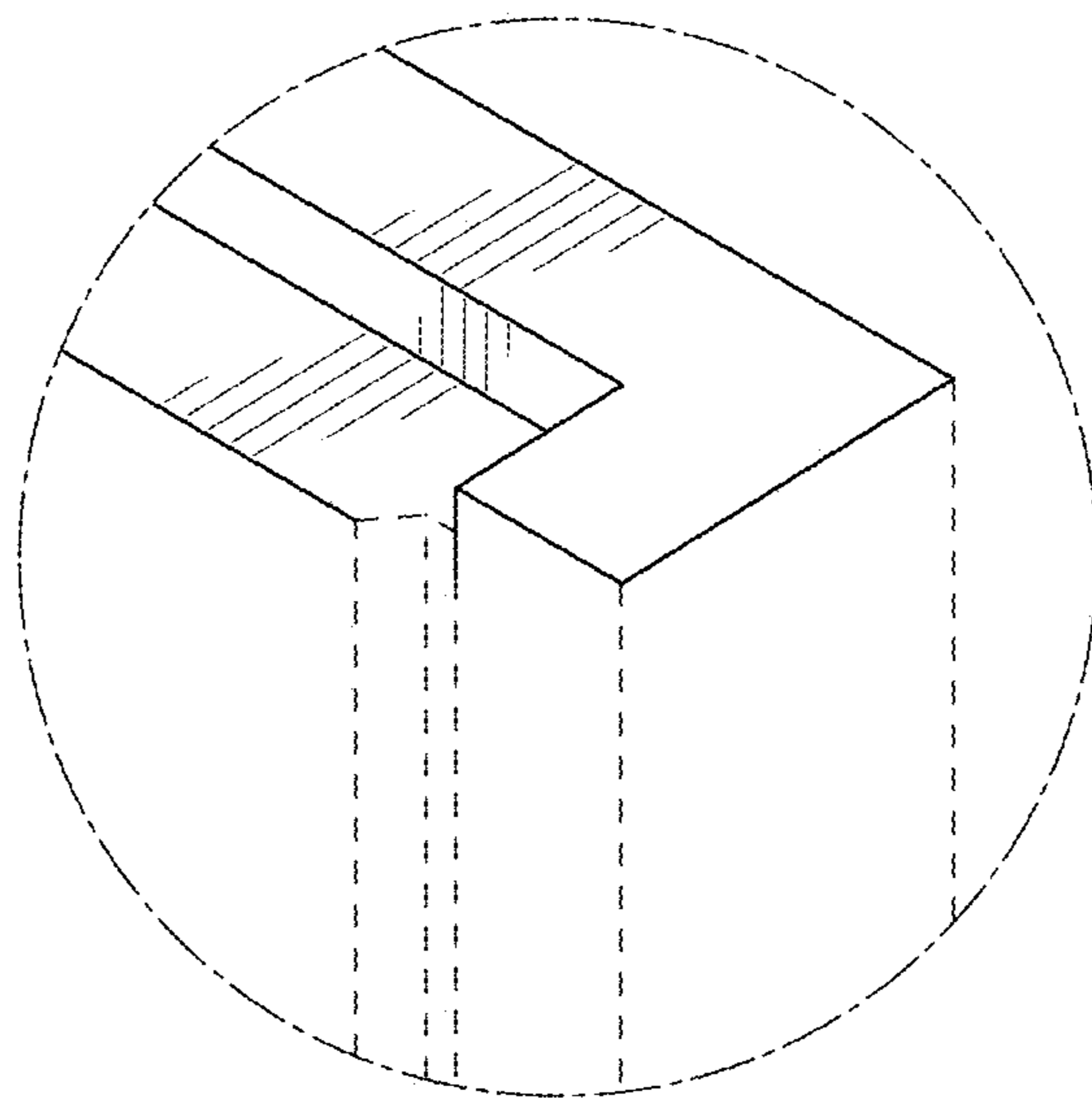

FIG. 4