



US00D884044S

(12) **United States Design Patent**
Keinänen

(10) **Patent No.:** **US D884,044 S**

(45) **Date of Patent:** **** May 12, 2020**

(54) **HEALTHCARE EQUIPMENT**

(71) Applicant: **OPTOMED OY**, Oulu (FI)

(72) Inventor: **Alpo Keinänen**, Oulu (FI)

(73) Assignee: **OPTOMED PLC**, Oulu (FI)

(**) Term: **15 Years**

(21) Appl. No.: **29/617,316**

(22) Filed: **Sep. 13, 2017**

(30) **Foreign Application Priority Data**

Jun. 22, 2017 (EM) 004061364-0001

(51) **LOC (12) Cl.** **16-06**

(52) **U.S. Cl.**
USPC **D16/131**

(58) **Field of Classification Search**
USPC D16/130, 131, 132, 133, 134, 135, 202,
D16/310, 140; D14/156, 167, 192, 218;
D24/121, 162, 186, 216, 219-221,
D24/224-233

CPC G02B 21/24; G02B 21/22
See application file for complete search history.

(56) **References Cited**

U.S. PATENT DOCUMENTS

3,545,355 A * 12/1970 Cahall, Jr. G03B 17/48
396/432
D262,823 S * 1/1982 House, II D24/146

D294,036 S * 2/1988 Yamada D16/131
D311,411 S * 10/1990 Sato D16/130
D325,861 S * 5/1992 Saito D8/68
D361,078 S * 8/1995 Atamian D16/131
D406,737 S * 3/1999 Farnham D8/29.1
D436,118 S * 1/2001 London D16/130
D523,883 S * 6/2006 Distasio D16/131
D655,325 S * 3/2012 Nojima D16/131
D655,326 S * 3/2012 Nojima D16/131
D655,327 S * 3/2012 Nojima D16/136
D786,875 S * 5/2017 Kaminaga D14/433

* cited by examiner

Primary Examiner — Mark A Goodwin

Assistant Examiner — Benjamin M Weeks

(74) *Attorney, Agent, or Firm* — Nixon & Vanderhye PC

(57) **CLAIM**

The ornamental design for healthcare equipment, as shown and described.

DESCRIPTION

FIG. 1 is a front perspective view according to my new design;

FIG. 2 is a front elevation view thereof;

FIG. 3 is a left side elevation view thereof;

FIG. 4 is a first rear perspective view thereof;

FIG. 5 is a rear elevation view thereof;

FIG. 6 is a second rear perspective view thereof; and,

FIG. 7 is a top plan view thereof.

1 Claim, 7 Drawing Sheets

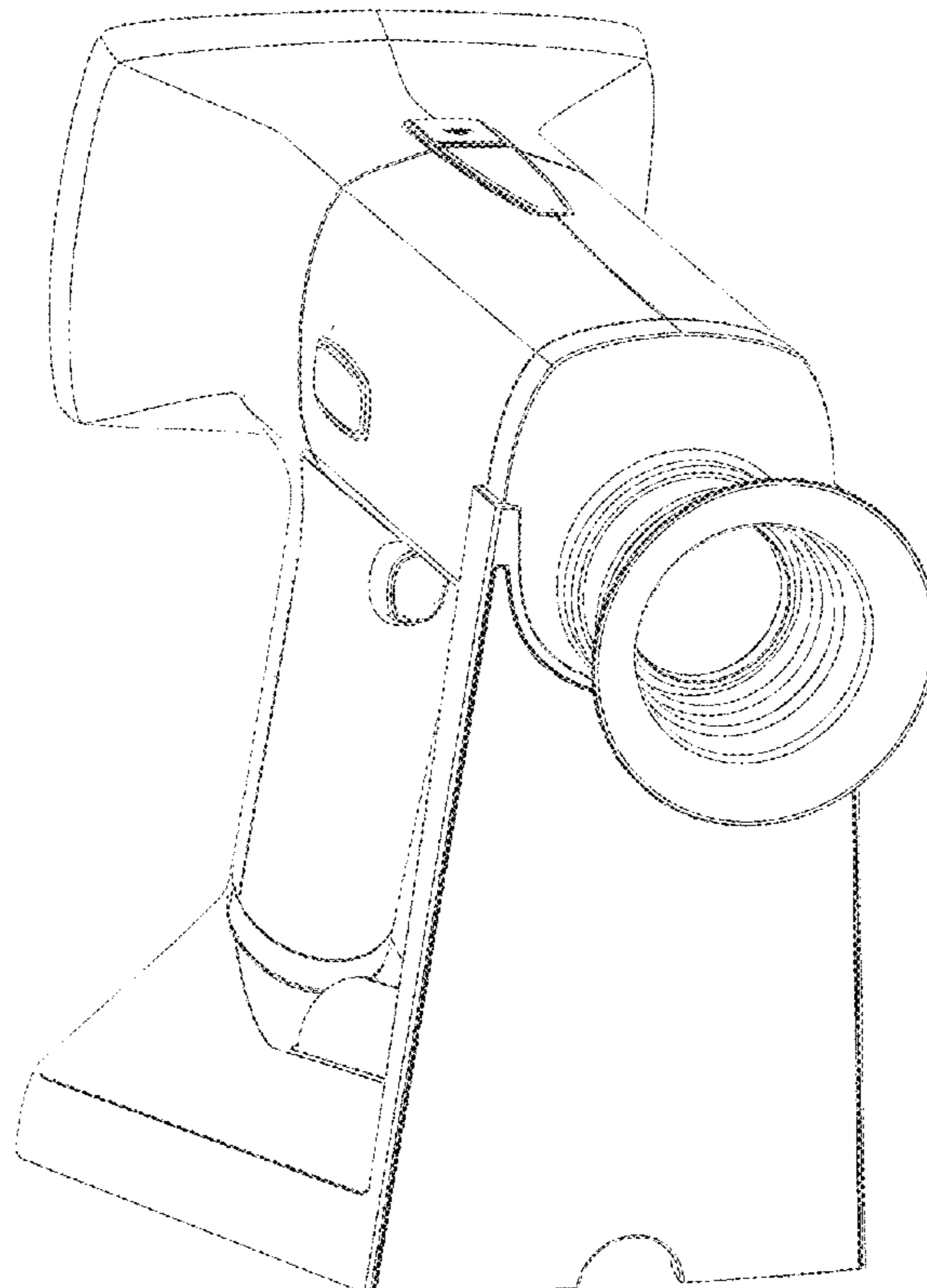

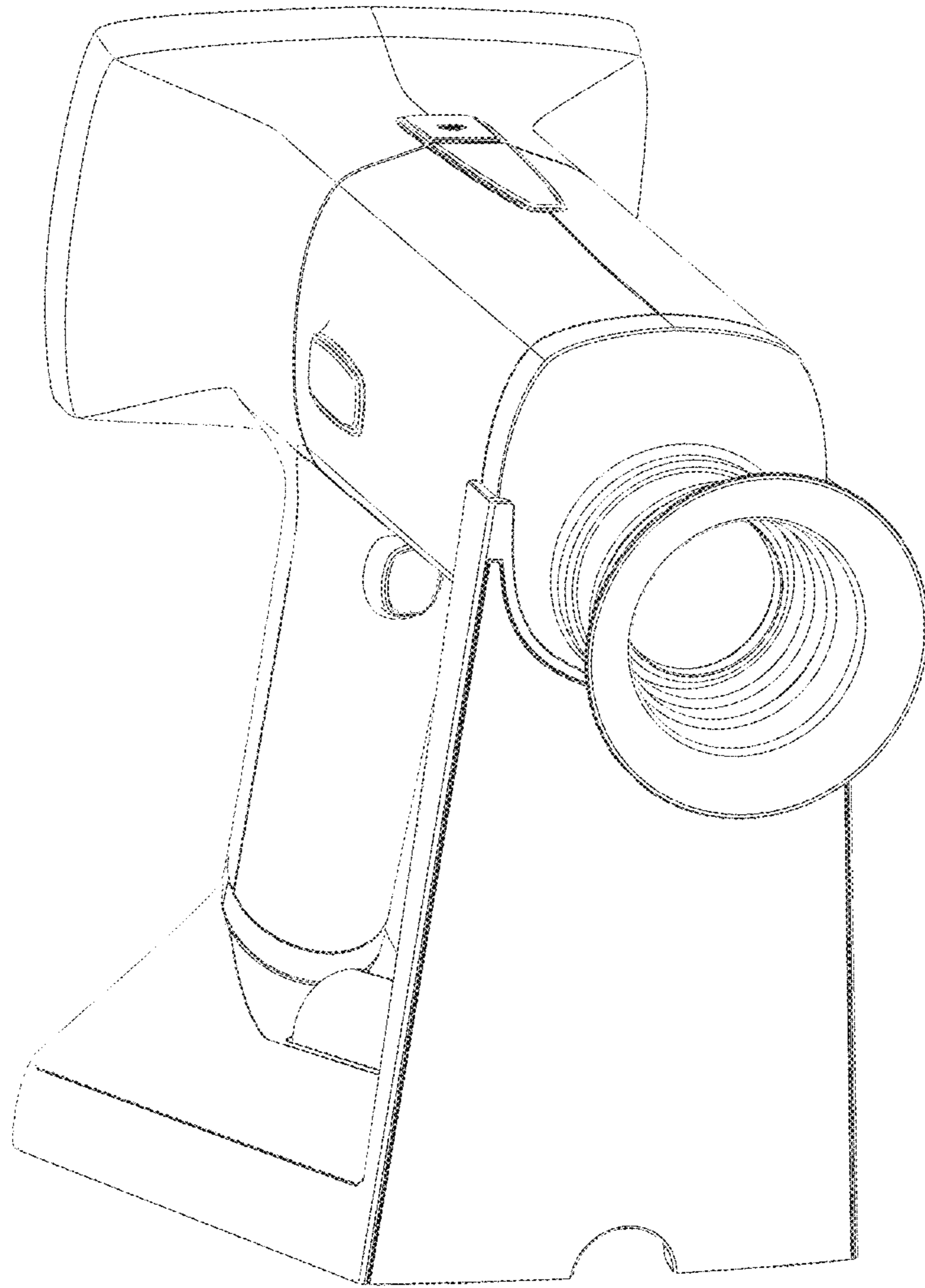

FIG. 1

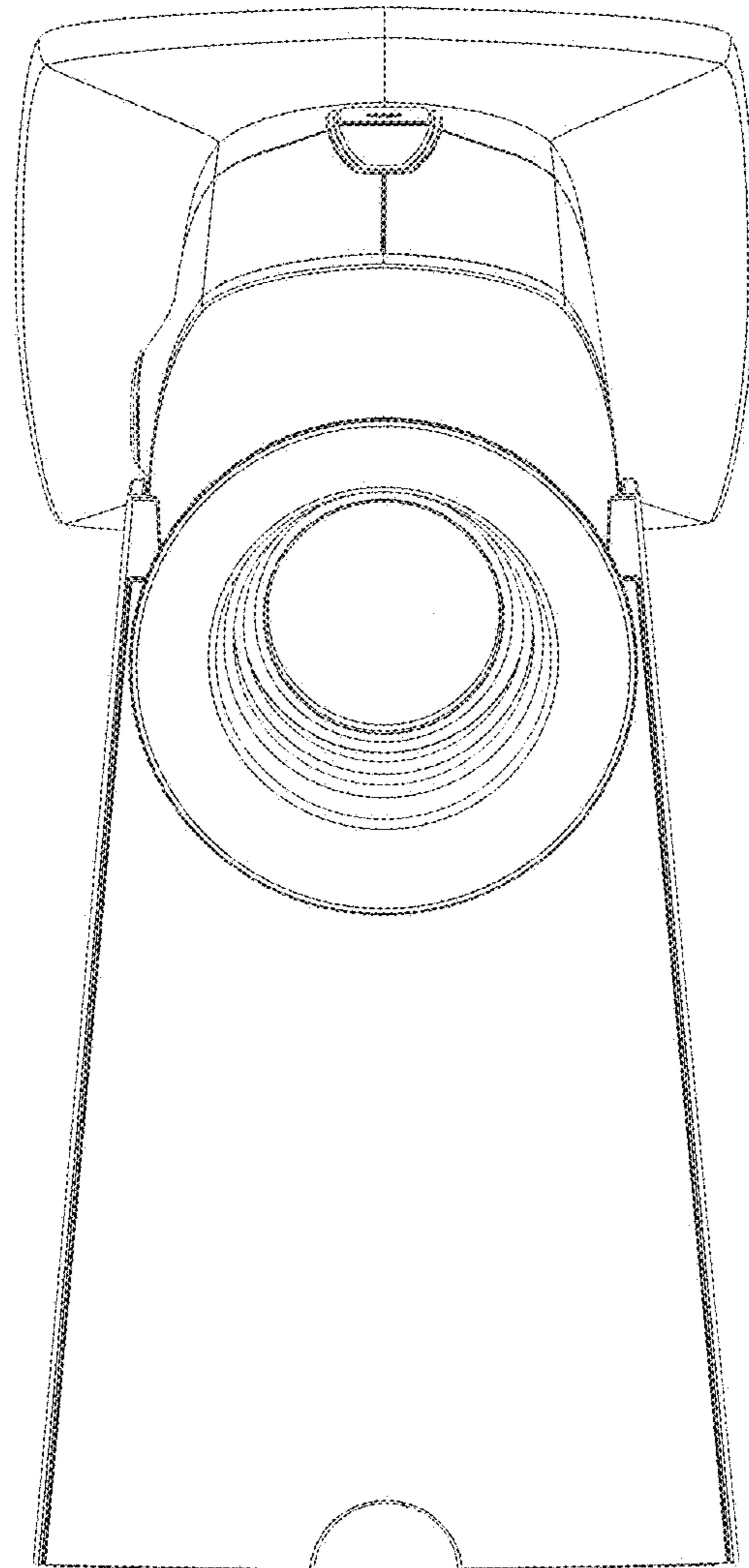

FIG. 2

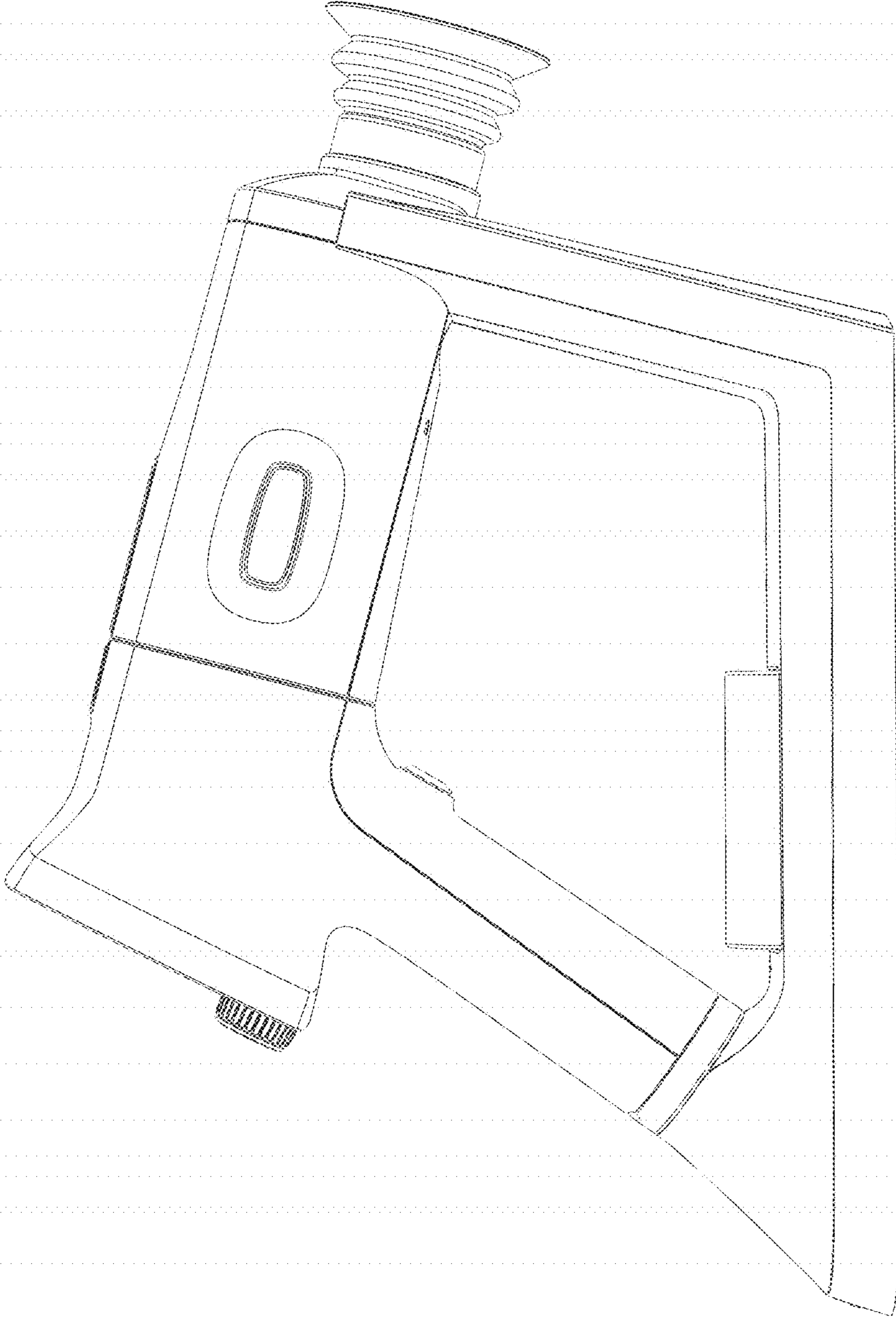

FIG. 3

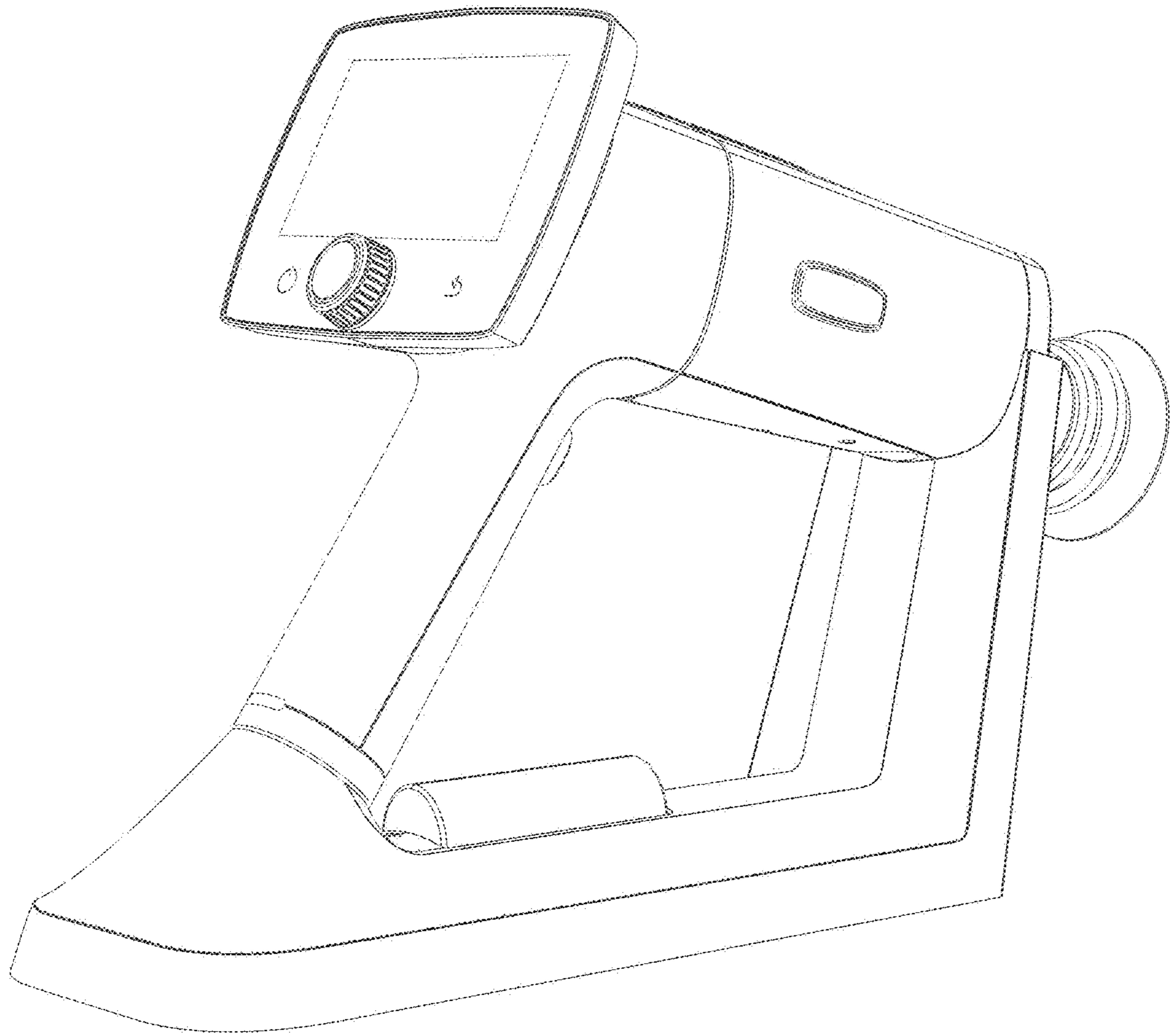

FIG. 4

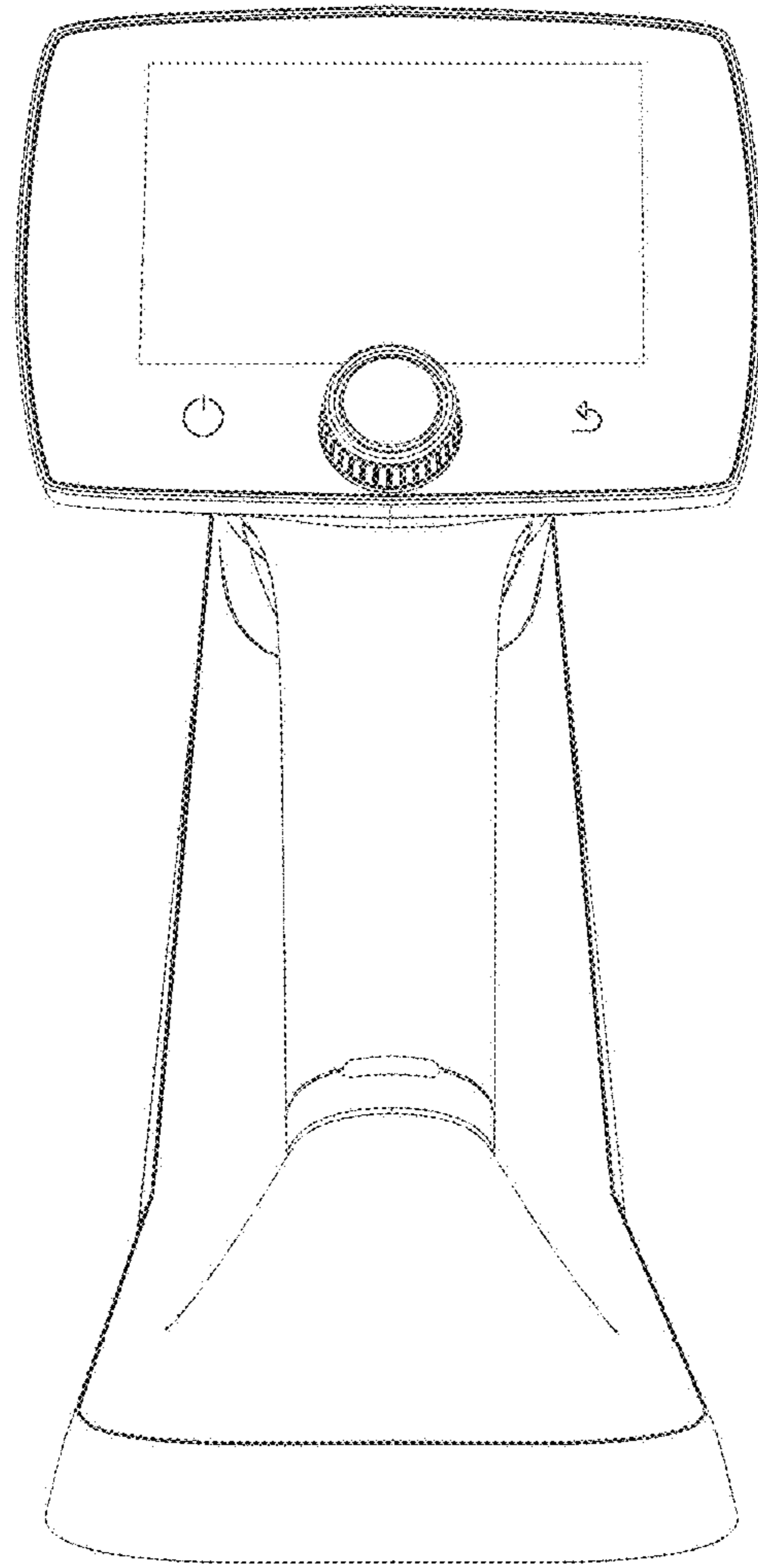

FIG. 5

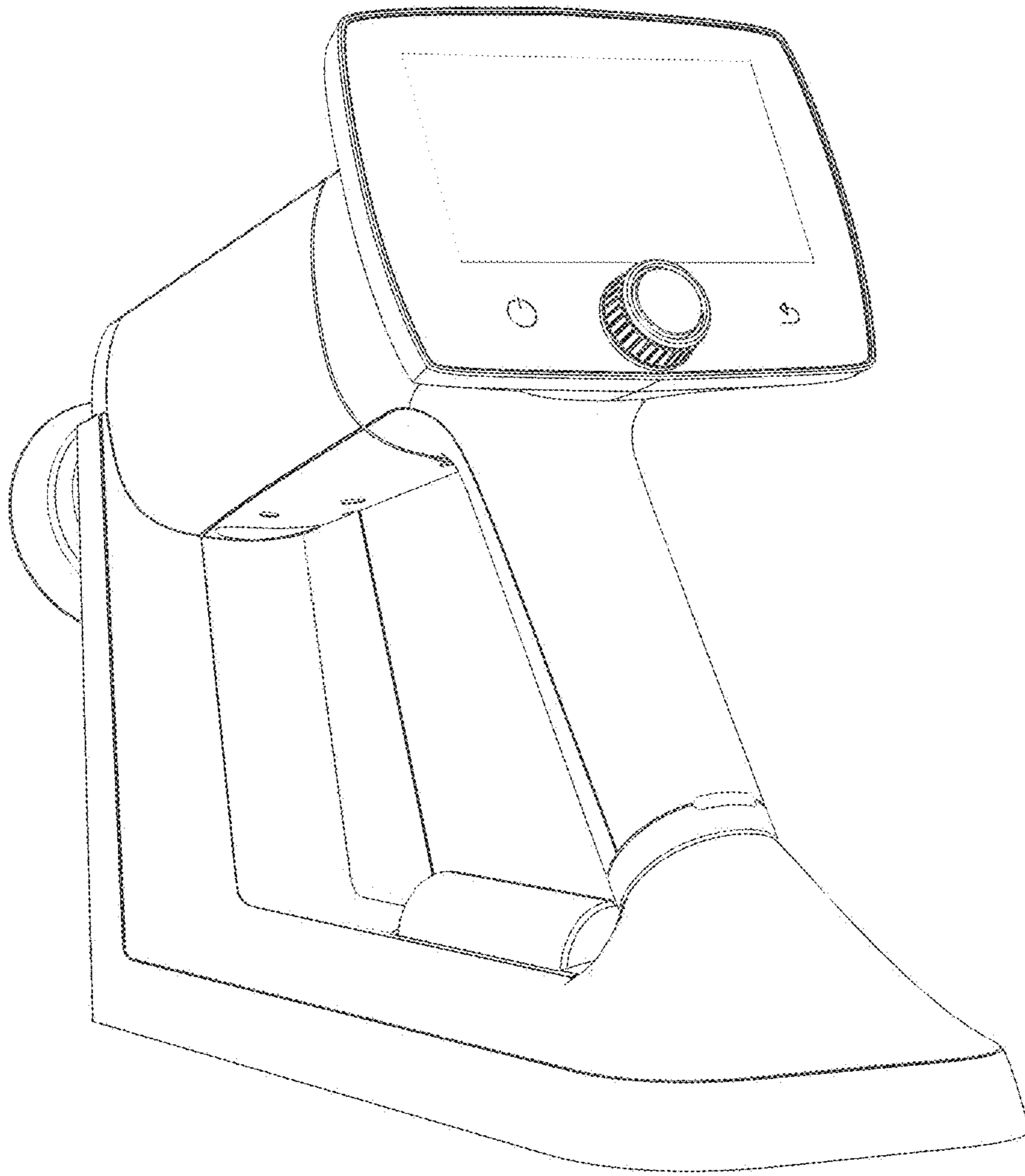

FIG. 6

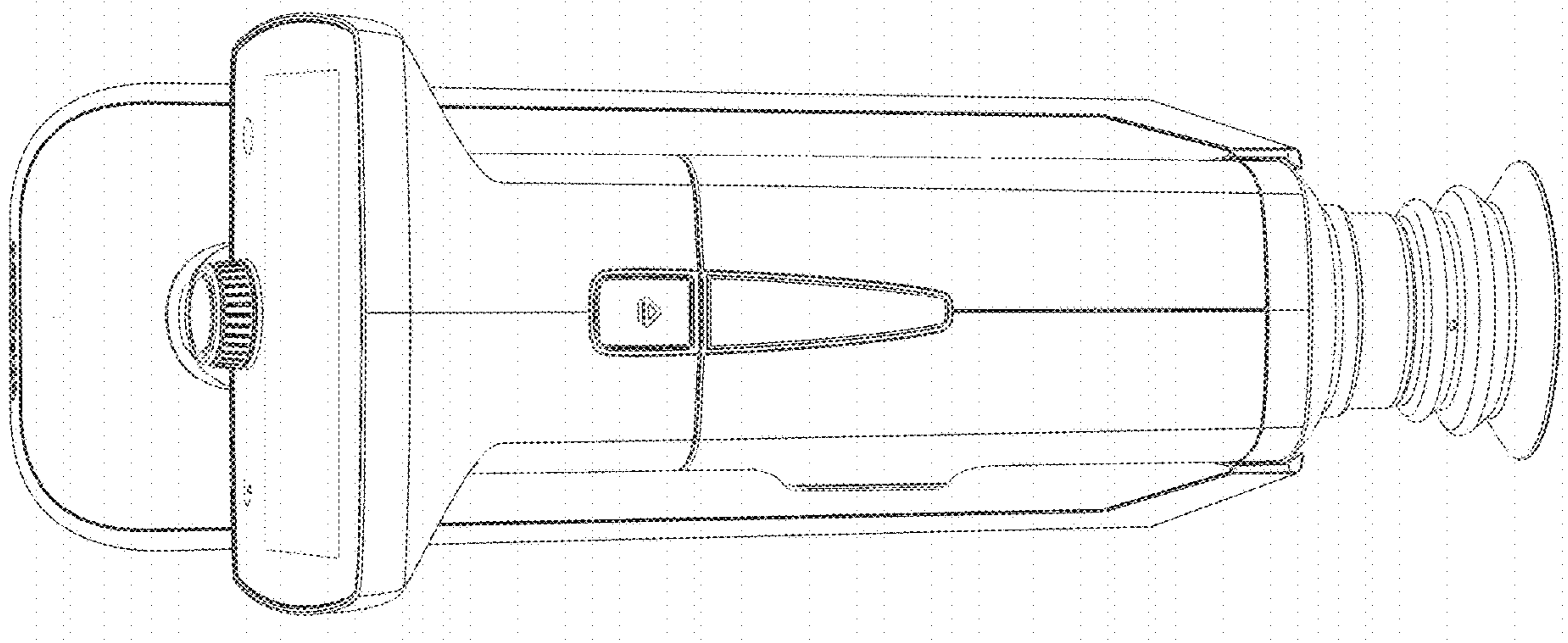

FIG. 7