



US00D883396S

(12) **United States Design Patent** (10) **Patent No.:** **US D883,396 S**
Deng (45) **Date of Patent:** **** May 5, 2020**

(54) **ELECTRIC SCOOTER**
(71) Applicant: **Guangzhou BionC Intelligent Sport Equipment Co., Ltd**, Guangzhou, Guangdong Province (CN)
(72) Inventor: **Junlin Deng**, Guangzhou (CN)
(**) Term: **15 Years**
(21) Appl. No.: **29/706,751**
(22) Filed: **Sep. 23, 2019**
(30) **Foreign Application Priority Data**
Aug. 16, 2019 (EM) 006731154
(51) **LOC (12) Cl.** **21-01**
(52) **U.S. Cl.**
USPC **D21/423**
(58) **Field of Classification Search**
USPC D21/419, 421, 423, 760, 765, 771;
D12/1
CPC B62K 3/002; B62K 9/00; B62K 2202/00;
B60Y 2200/126
See application file for complete search history.

(56) **References Cited**
U.S. PATENT DOCUMENTS
D441,323 S * 5/2001 Cheng D12/111
D445,144 S * 7/2001 Lin D21/423
D464,379 S * 10/2002 Lin D21/423
D479,285 S * 9/2003 Jung D21/423
D513,629 S * 1/2006 Sramek D21/423
D513,772 S * 1/2006 Otis D21/423
D581,991 S * 12/2008 Armand D21/423

D710,949 S * 8/2014 Huang D21/423
D755,899 S * 5/2016 Castrucci D21/423
D797,200 S * 9/2017 Ratner D21/423
D804,581 S * 12/2017 Schindele D21/423
D839,359 S 1/2019 Hadley
D866,674 S * 11/2019 Li D21/423
2004/0129471 A1* 7/2004 Cheng B62K 3/002
180/181

* cited by examiner
Primary Examiner — Cynthia M. Chin
(74) *Attorney, Agent, or Firm* — Jie Yang; ZanIP

(57) **CLAIM**
The ornamental design for an electric scooter, as shown and described.

DESCRIPTION
FIG. 1 is a front and top perspective view of an electric scooter, showing my new design;
FIG. 2 is a rear and bottom perspective view thereof;
FIG. 3 is a front elevational view thereof;
FIG. 4 is a rear elevational view thereof;
FIG. 5 is a left side elevational view thereof;
FIG. 6 is a right side elevational view thereof;
FIG. 7 is a top plan view thereof;
FIG. 8 is a bottom plan view thereof;
FIG. 9 is a partial enlarged view of the handlebar in FIG. 1;
FIG. 10 is a partial enlarged view of the kickstand area in FIG. 2; and,
FIG. 11 is a partial enlarged view of the front suspension area in FIG. 5.
The dash-dot broken lines represent the boundaries of the enlarged partial views of FIGS. 9-11 and form no part of the claimed design.

1 Claim, 11 Drawing Sheets

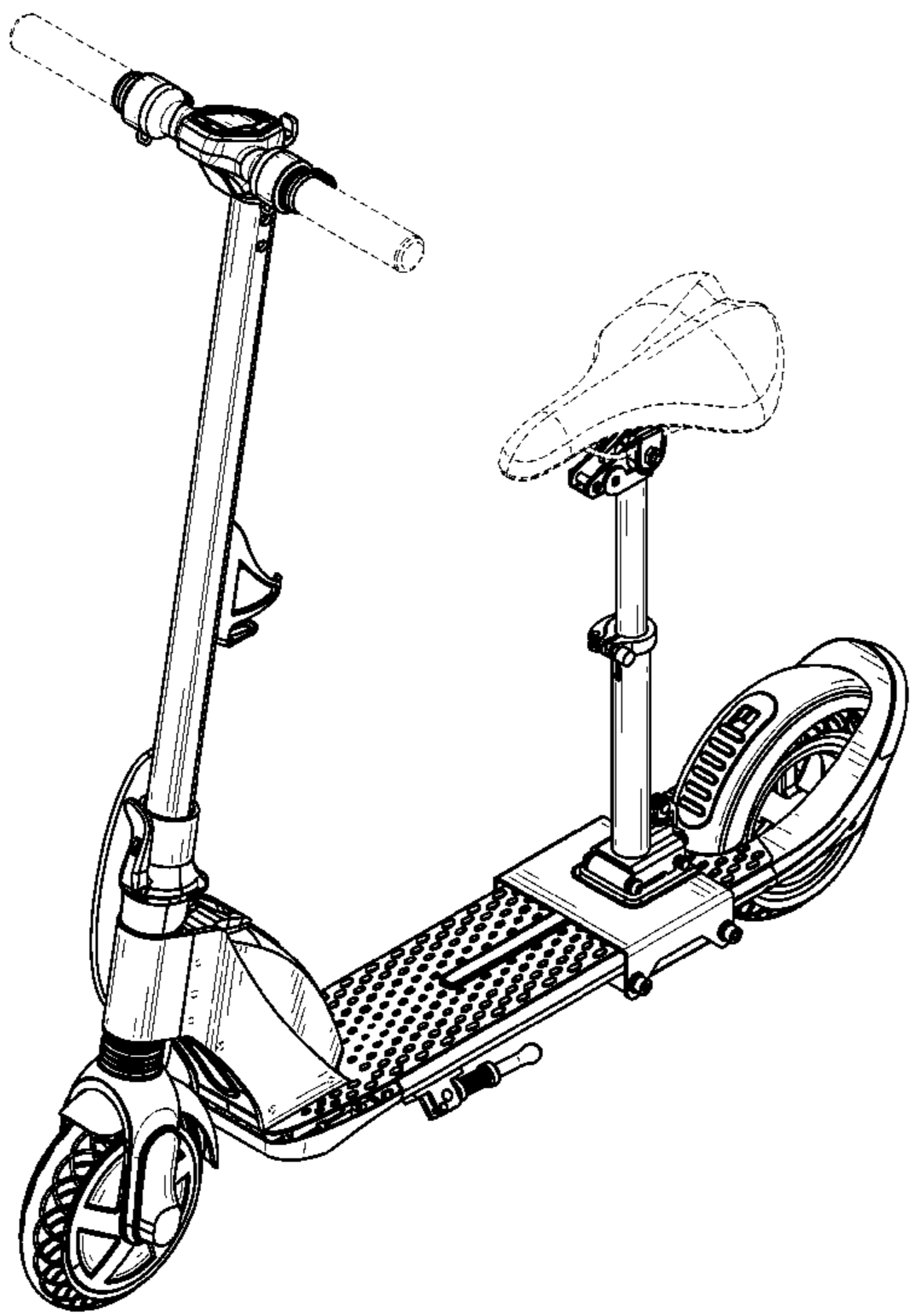

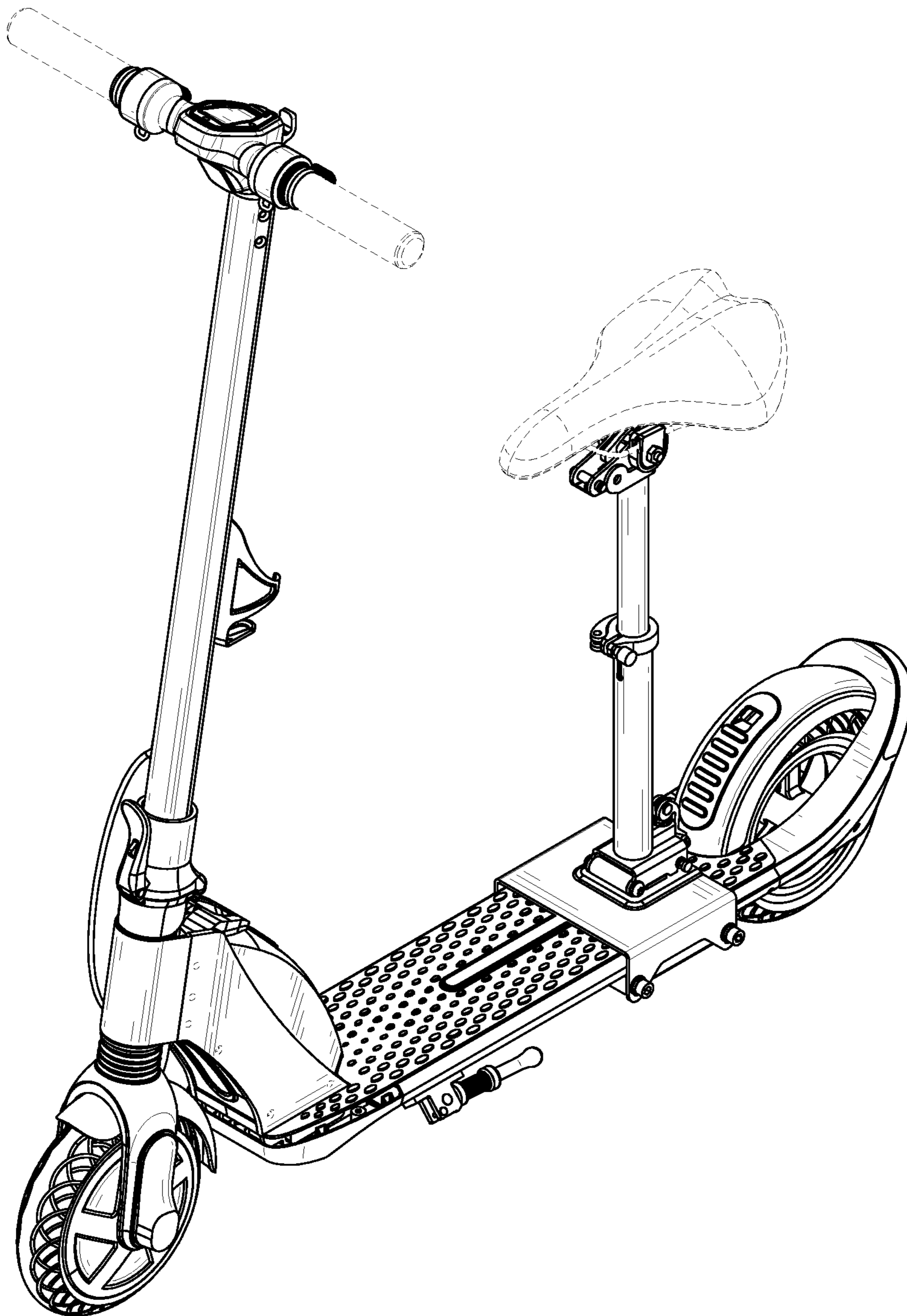

FIG. 1

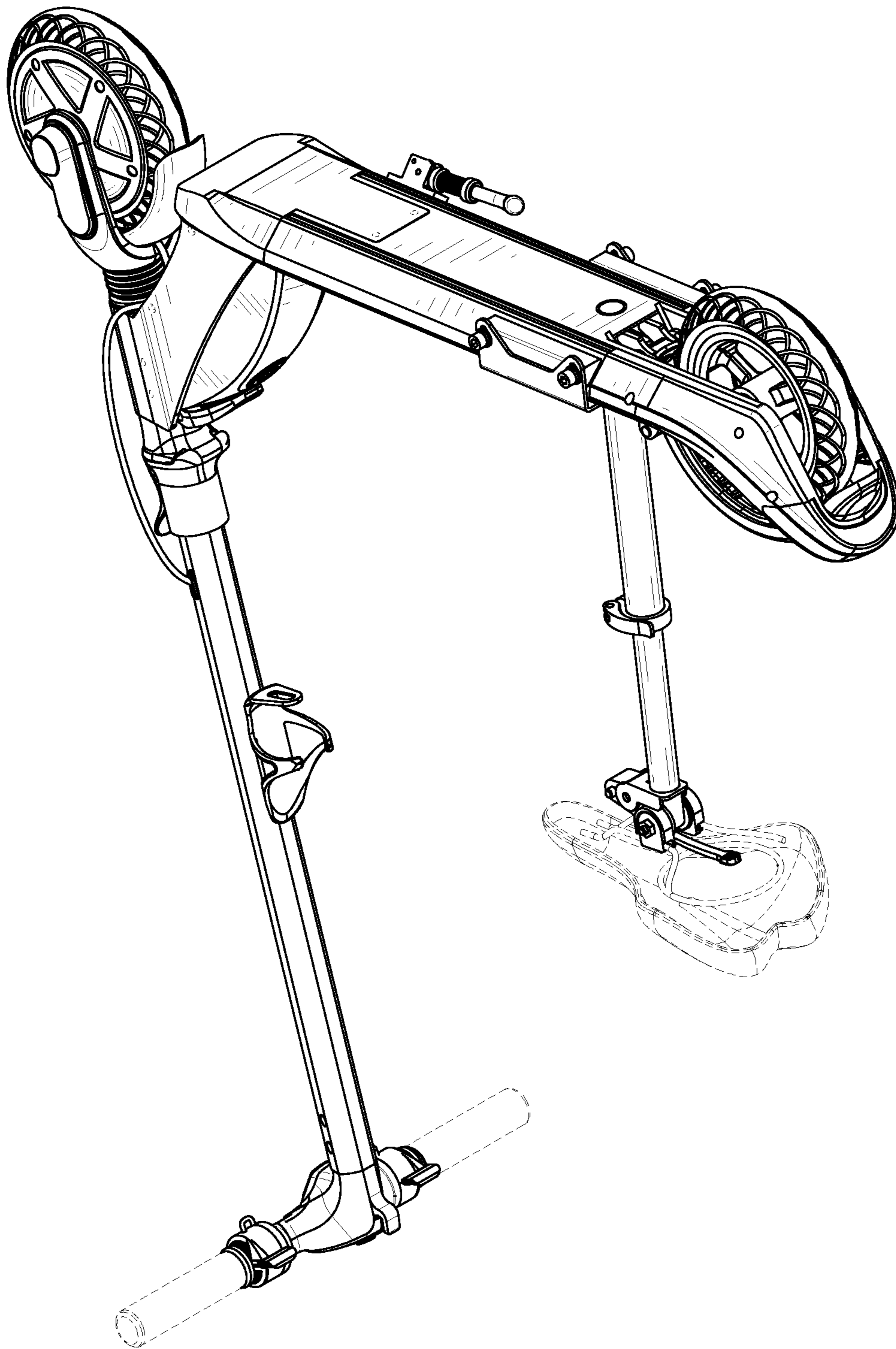

FIG. 2

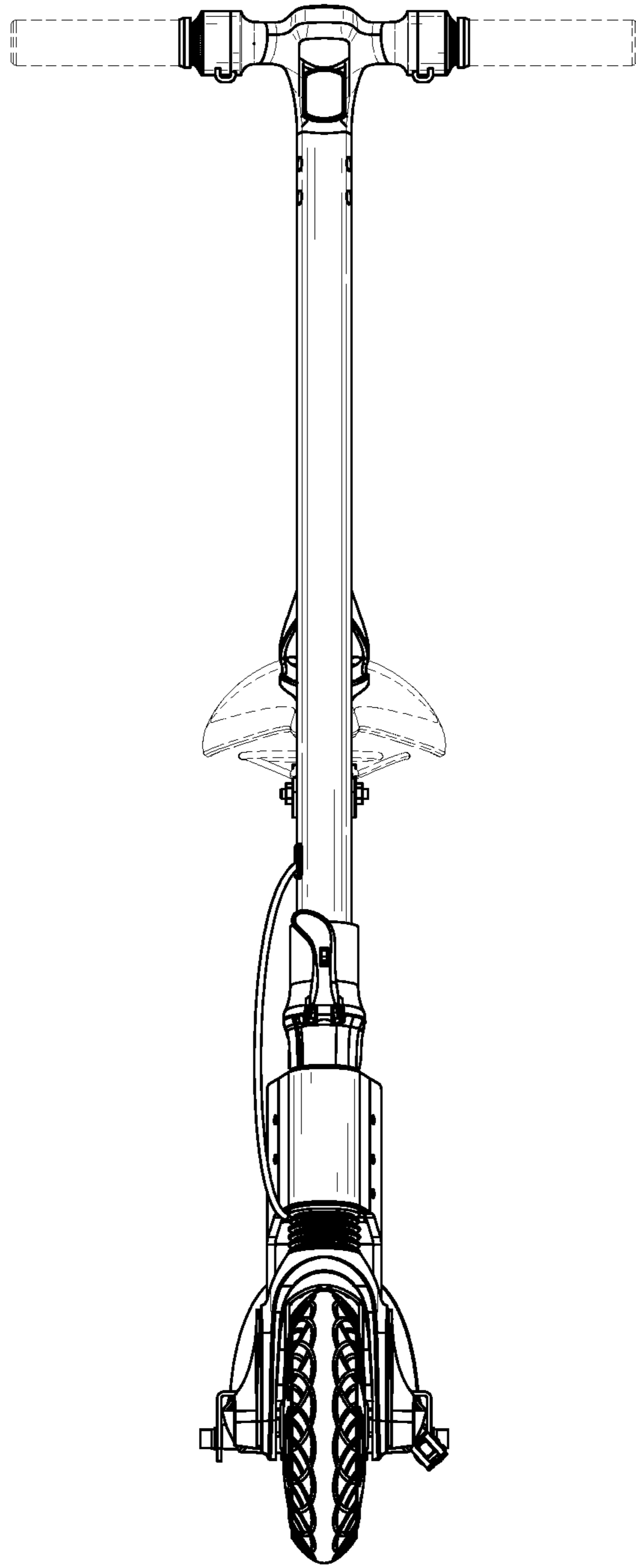

FIG. 3

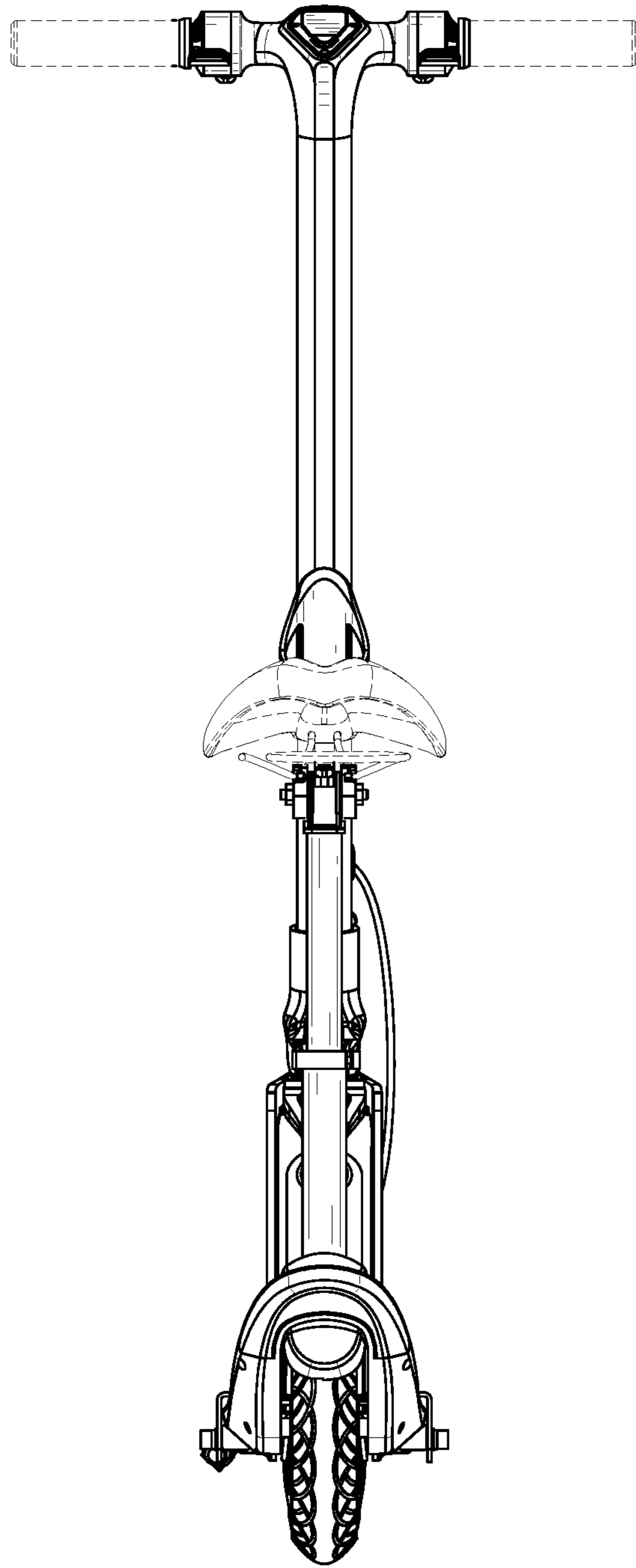

FIG. 4

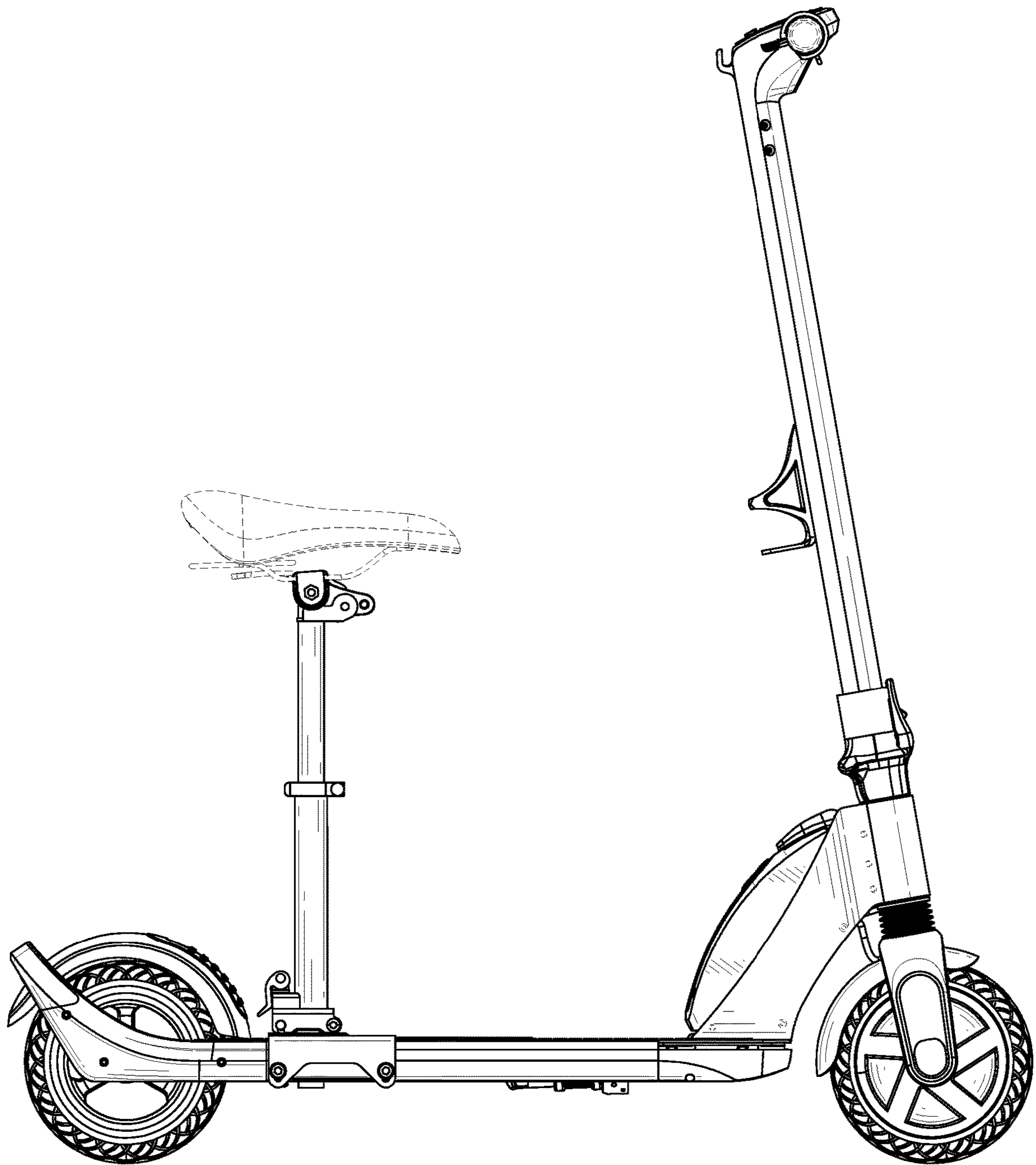

FIG. 5

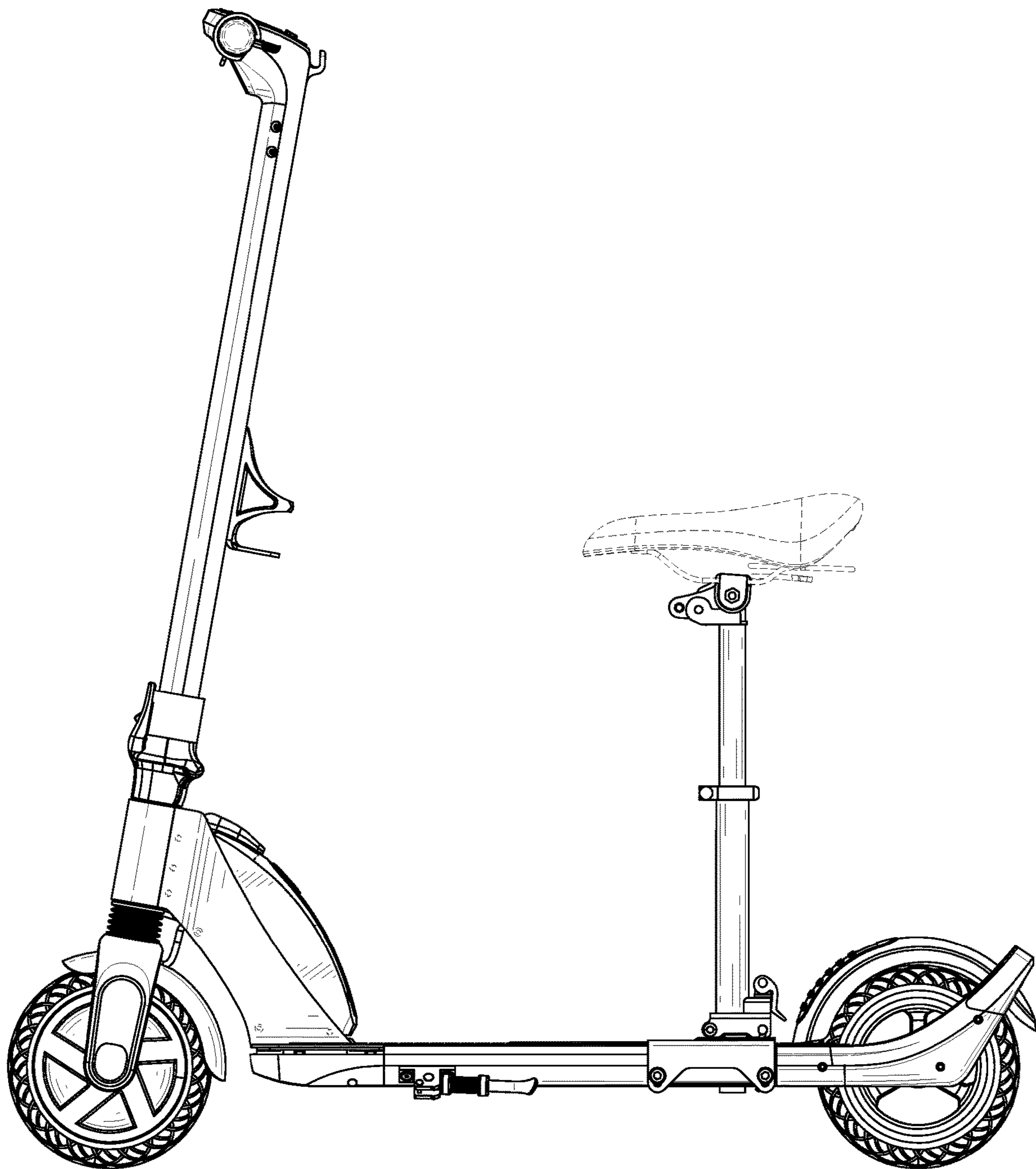

FIG. 6

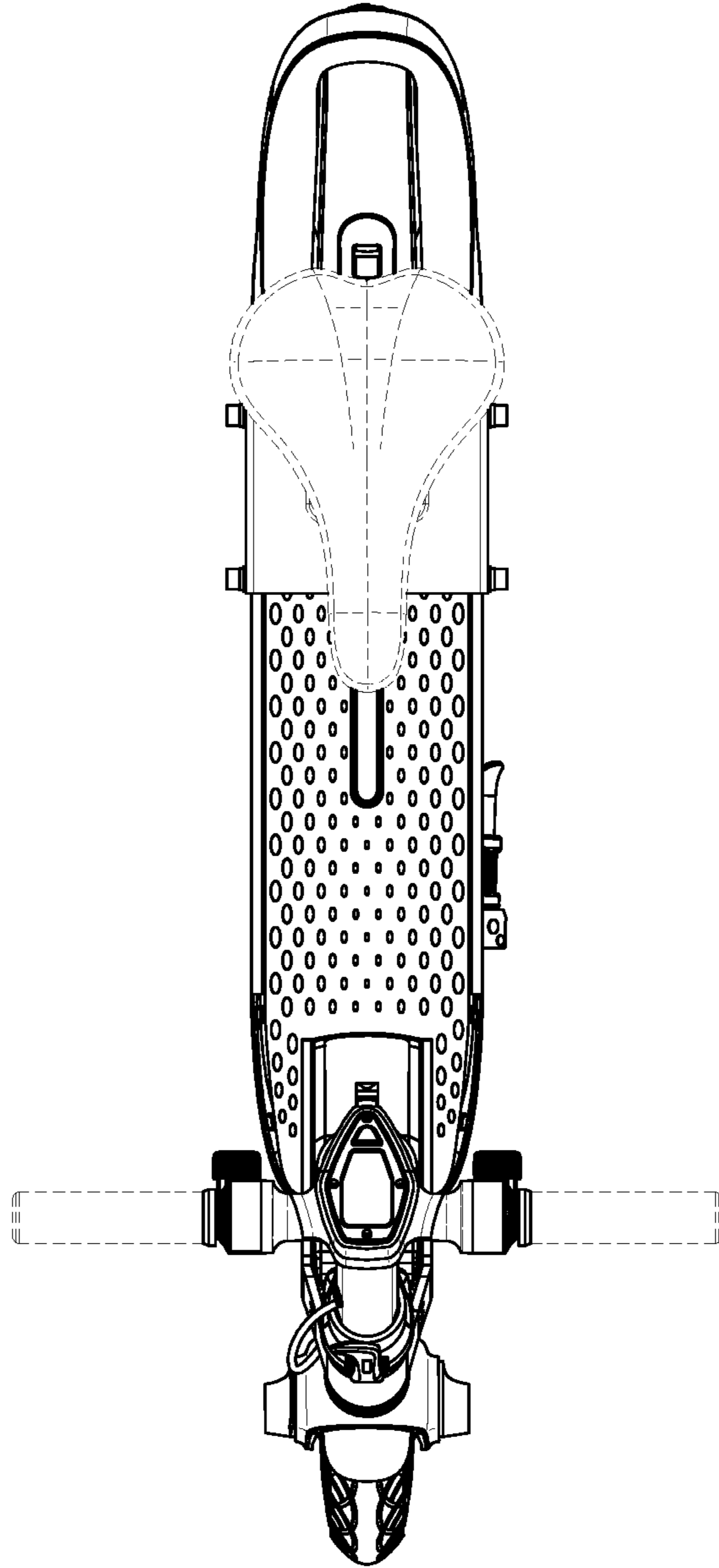

FIG. 7

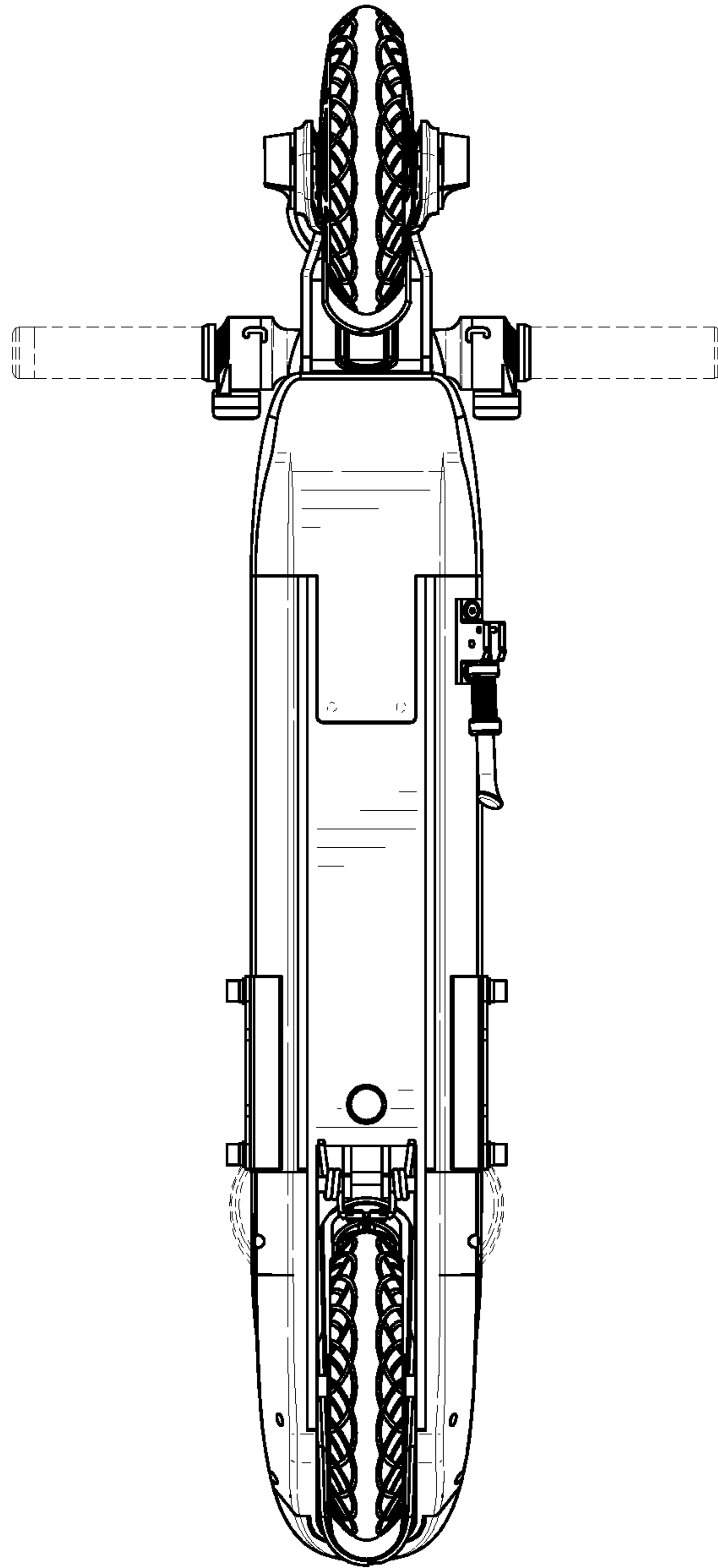

FIG. 8

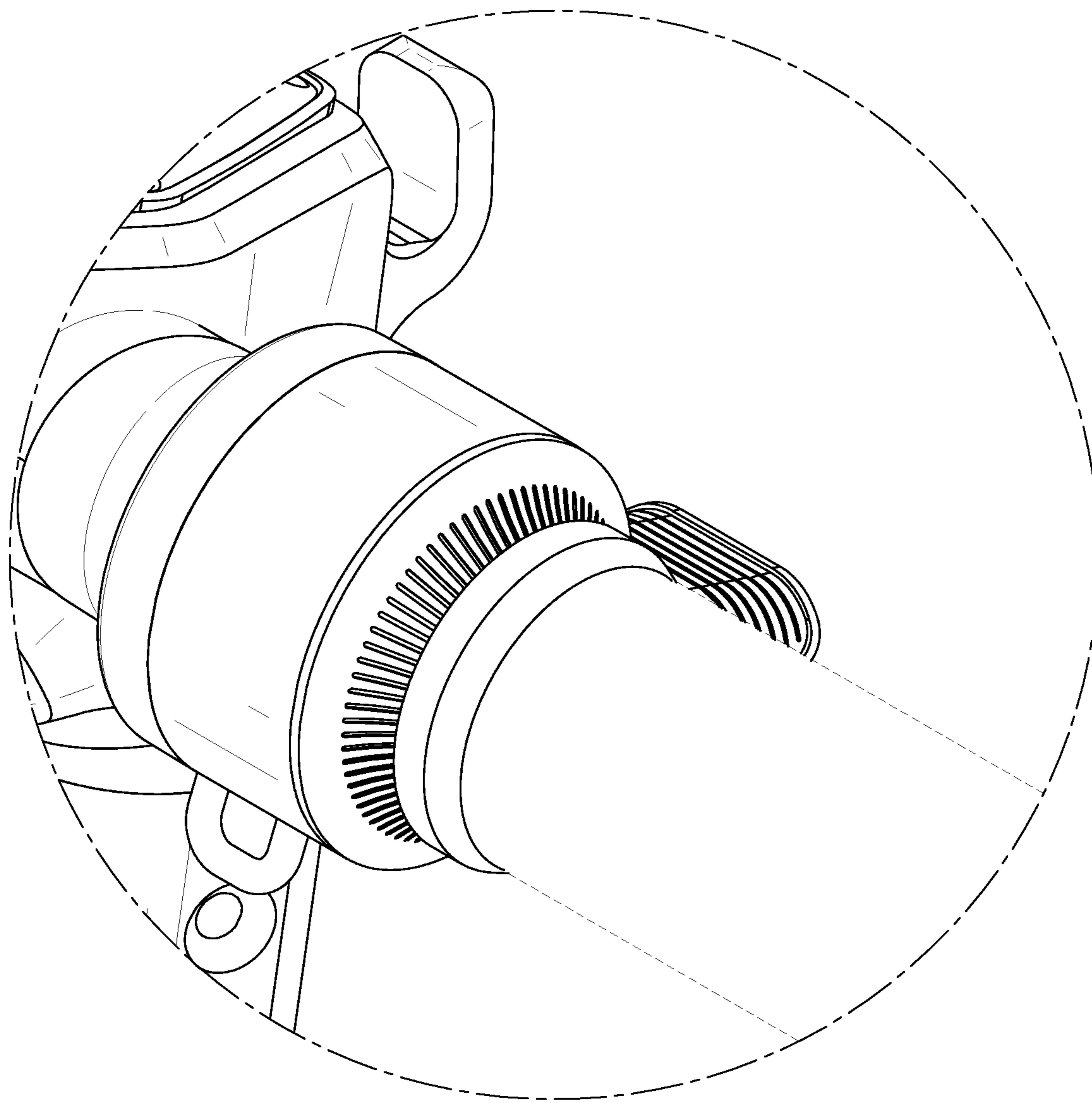

FIG. 9

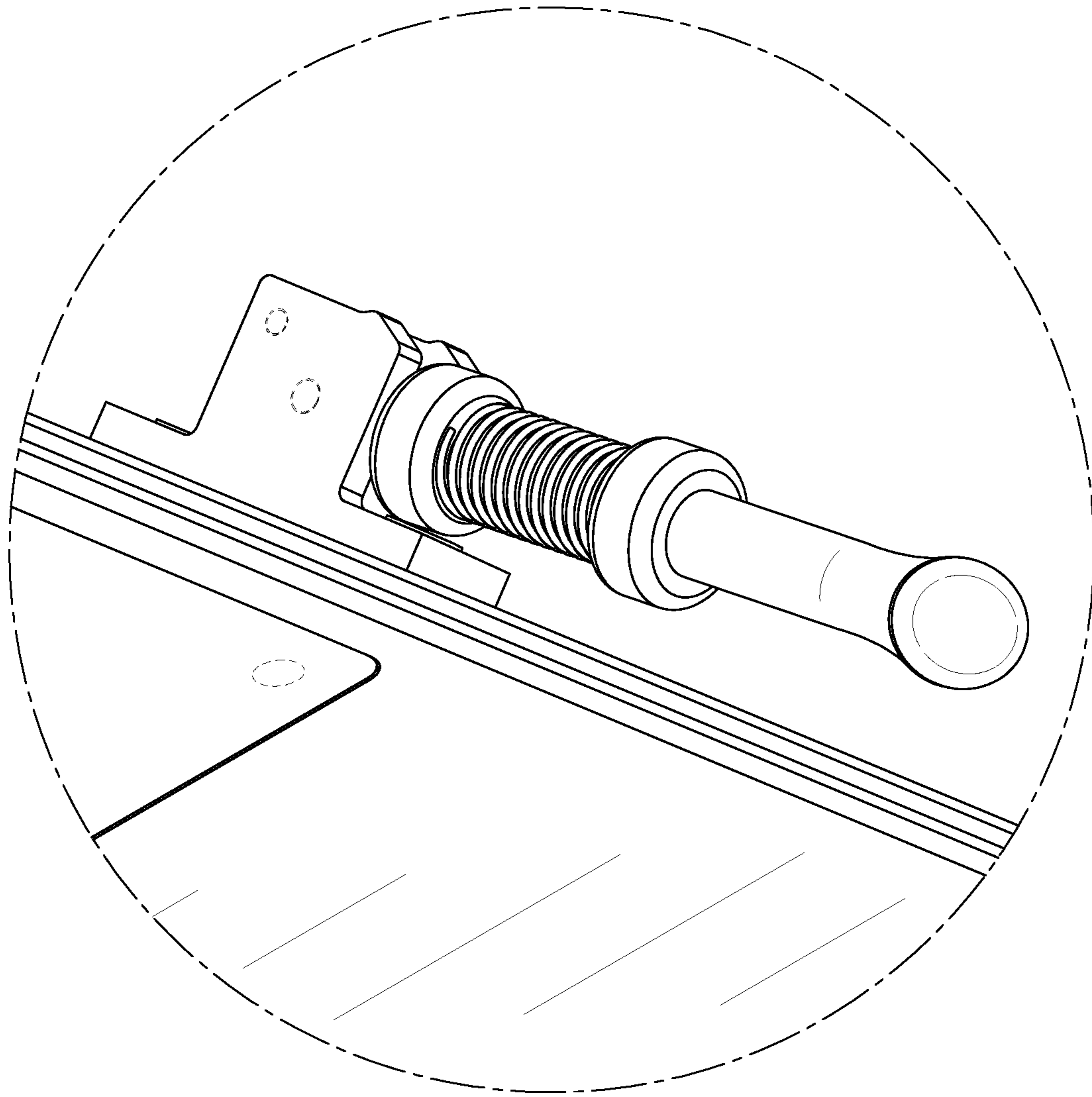

FIG. 10

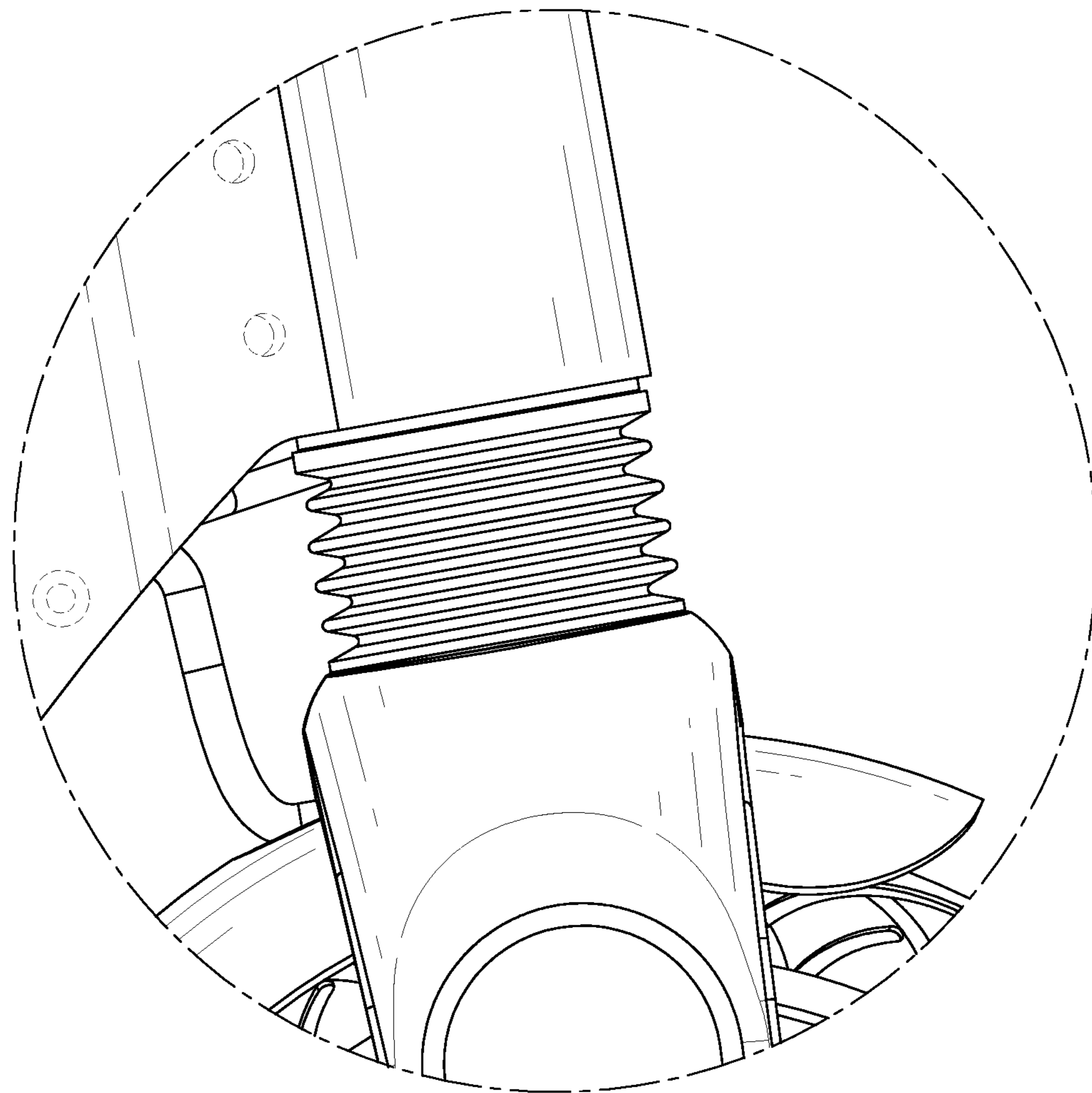

FIG. 11