



US00D882641S

(12) **United States Design Patent**
Moja et al.

(10) **Patent No.:** **US D882,641 S**
(45) **Date of Patent:** **** Apr. 28, 2020**

(54) **TWO-PRONGED LATCH FOR DOWNHOLE TOOL**

FOREIGN PATENT DOCUMENTS

(71) Applicant: **Unseated Tools LLC**, Williston, ND (US)

CA	179452	3/2019
GB	2294714	5/1996
GB	2314391	12/1997

(72) Inventors: **Andrew T. Moja**, Williston, ND (US);
William F. Marshall, Pittsburg, KS (US)

Primary Examiner — Mark A Goodwin

(74) *Attorney, Agent, or Firm* — Peter L. Brewer; Thrive IP

(73) Assignee: **Unseated Tools LLC**, Williston, ND (US)

(57) **CLAIM**

We claim the ornamental design for a two-pronged latch for a downhole tool, as shown and described.

(**) Term: **15 Years**

DESCRIPTION

(21) Appl. No.: **29/611,746**

FIG. 1 is a perspective view of a two-pronged latch for a downhole tool showing our new design.

(22) Filed: **Jul. 25, 2017**

FIG. 2 is a perspective view of the prongs of the two-pronged latch of FIG. 1.

(51) **LOC (12) Cl.** **15-03**

FIG. 3 is a front plan view of the prongs of the two-pronged latch of FIG. 1.

(52) **U.S. Cl.**

FIG. 4 is a rear plan view thereof.

USPC **D15/21**

FIG. 5 is a top plan view thereof.

(58) **Field of Classification Search**

USPC D15/21; 29/221.6, 264; 294/86.1, 86.31

FIG. 6 is a bottom plan view thereof.

CPC B25B 27/24; E21B 31/18; E21B 31/00;

FIG. 7 is a right side elevation view thereof.

E21B 31/20; E21B 31/12; E21B 43/127;

FIG. 8 is a left side elevation view thereof.

E21B 34/14; Y10T 29/53596; Y10T

FIG. 9 is a front plan view of one of the prongs of the two-pronged latch of FIG. 1.

29/53883

FIG. 10 is a perspective view of the two-pronged latch for a downhole tool, wherein the two prongs have pivoted outwardly about respective pin-holes.

See application file for complete search history.

FIG. 11 is a front plan view of the two-pronged latch of FIG. 9.

(56) **References Cited**

U.S. PATENT DOCUMENTS

1,576,597 A	3/1926	Goss
1,614,771 A	1/1927	Axelson
1,628,901 A	5/1927	Neilsen
1,676,661 A	7/1928	Nielsen
1,692,005 A	11/1928	Turner
2,142,494 A	1/1939	Cartwright
2,191,380 A	2/1940	Hall
2,242,602 A	5/1941	Watson
2,260,127 A	10/1941	Tebbetts

FIG. 12 is a rear plan view thereof

FIG. 13 is a top plan view thereof.

FIG. 14 is a bottom plan view thereof.

FIG. 15 is a right side elevation view thereof; and,

FIG. 16 is a left side elevation view thereof.

The structural features shown in broken lines have been shown for the purpose of illustrating environment, and form no part of the claimed design.

(Continued)

1 Claim, 10 Drawing Sheets

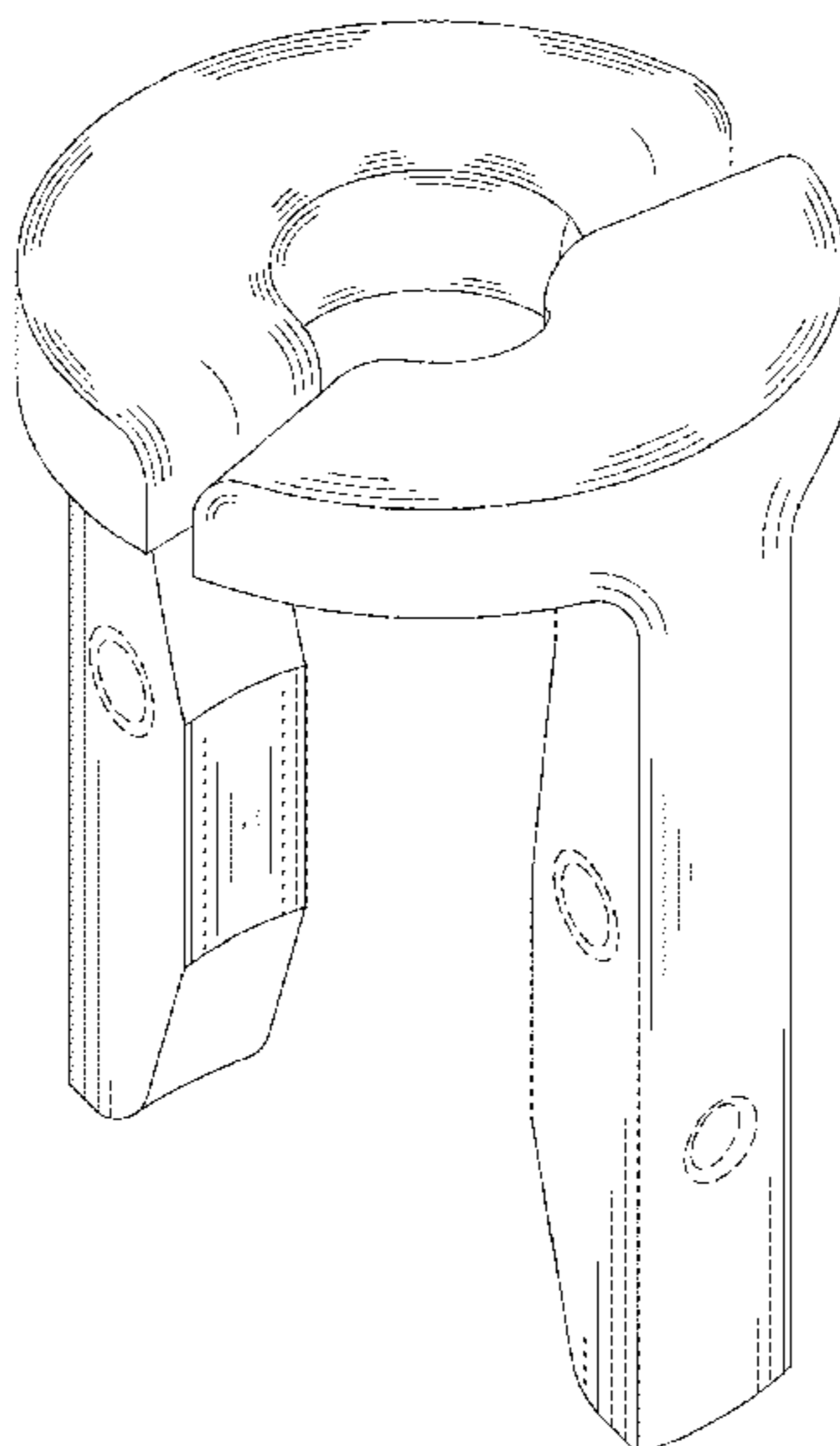

(56)

References Cited

U.S. PATENT DOCUMENTS

2,286,550 A	6/1942	Kelly		5,160,180 A	11/1992	Mlynarczyk	
2,319,514 A	5/1943	Penfield		5,197,773 A	3/1993	Vick	
2,605,131 A	7/1952	Marshall		5,207,730 A *	5/1993	Ruggiero	B25D 1/16 29/255
2,647,008 A	7/1953	Stewart		5,988,719 A *	11/1999	Lavender	B66C 1/56 294/96
3,208,531 A	9/1965	Tamplen		6,196,309 B1	3/2001	Estilette	
3,606,402 A	9/1971	Medney		6,554,320 B2	4/2003	Cresswell	
3,918,679 A	11/1975	Silvana		6,764,103 B1	7/2004	Moretz	
3,990,727 A	11/1976	Gallagher		7,690,430 B1	4/2010	Hunziker	
4,051,899 A	10/1977	Fredd		7,775,291 B2	8/2010	Jacob	
4,391,547 A	7/1983	Jackson		D673,183 S *	12/2012	Frazier	D15/21
4,436,125 A	3/1984	Blenkush		8,356,394 B1	1/2013	Heinle	
4,524,998 A	6/1985	Brisco		D684,612 S *	6/2013	Frazier	D15/139
4,802,694 A	2/1989	Vargo		D694,280 S *	11/2013	Frazier	D15/21
4,944,345 A	7/1990	Mashaw		8,585,110 B2 *	11/2013	Belik	E21B 31/20 294/86.25
4,997,225 A *	3/1991	Denis	E21B 31/20 294/86.25	D698,370 S *	1/2014	Frazier	D15/21
5,020,591 A	6/1991	Shore		D703,698 S *	4/2014	Frazier	D15/21
5,150,752 A *	9/1992	Gunst et al.	E21B 33/02 166/97.1	D703,713 S *	4/2014	Frazier	D15/139
				D705,821 S *	5/2014	Frazier	D15/21
				2019/0353007 A1 *	11/2019	Moja	E21B 31/18

* cited by examiner

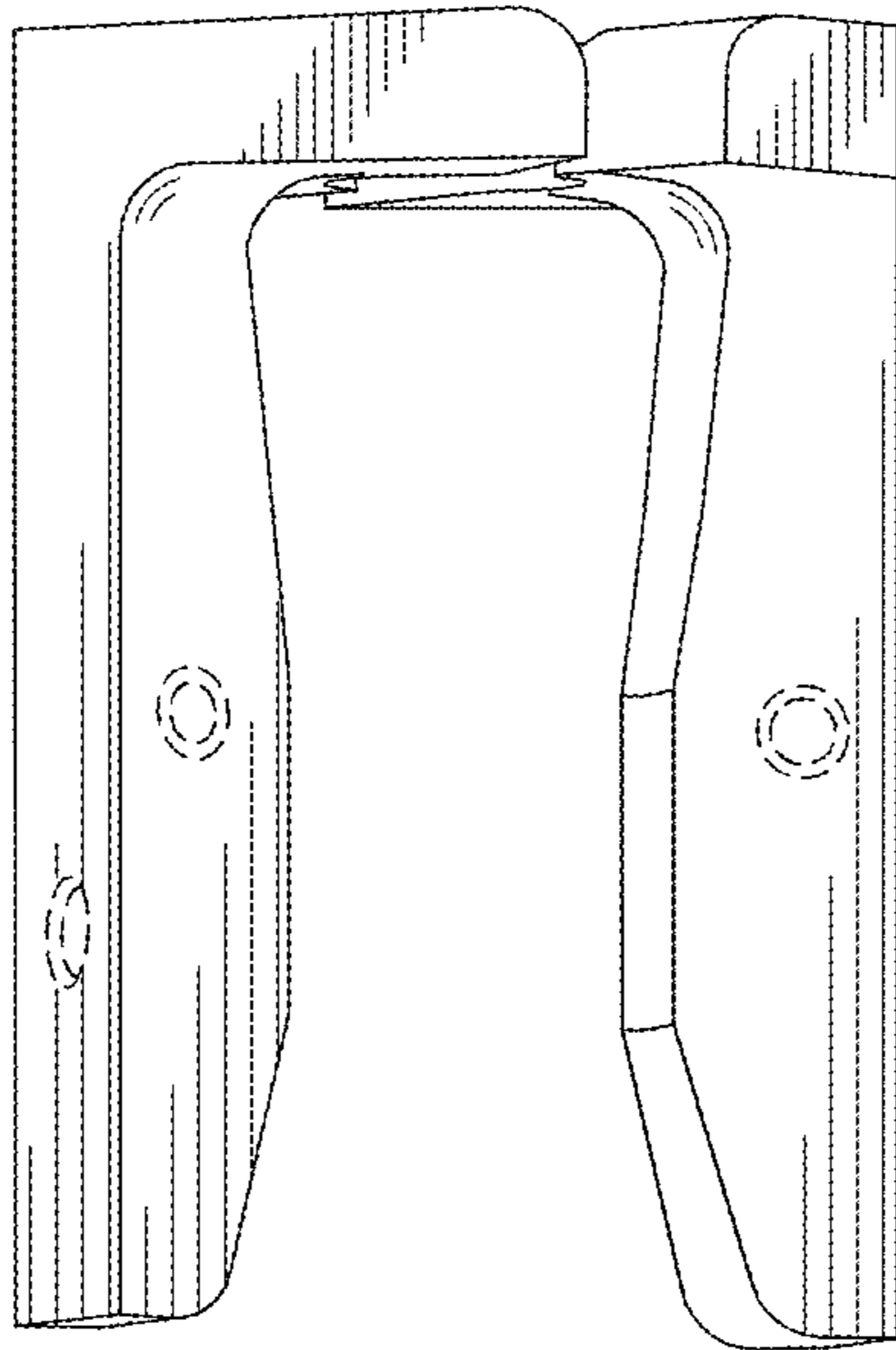
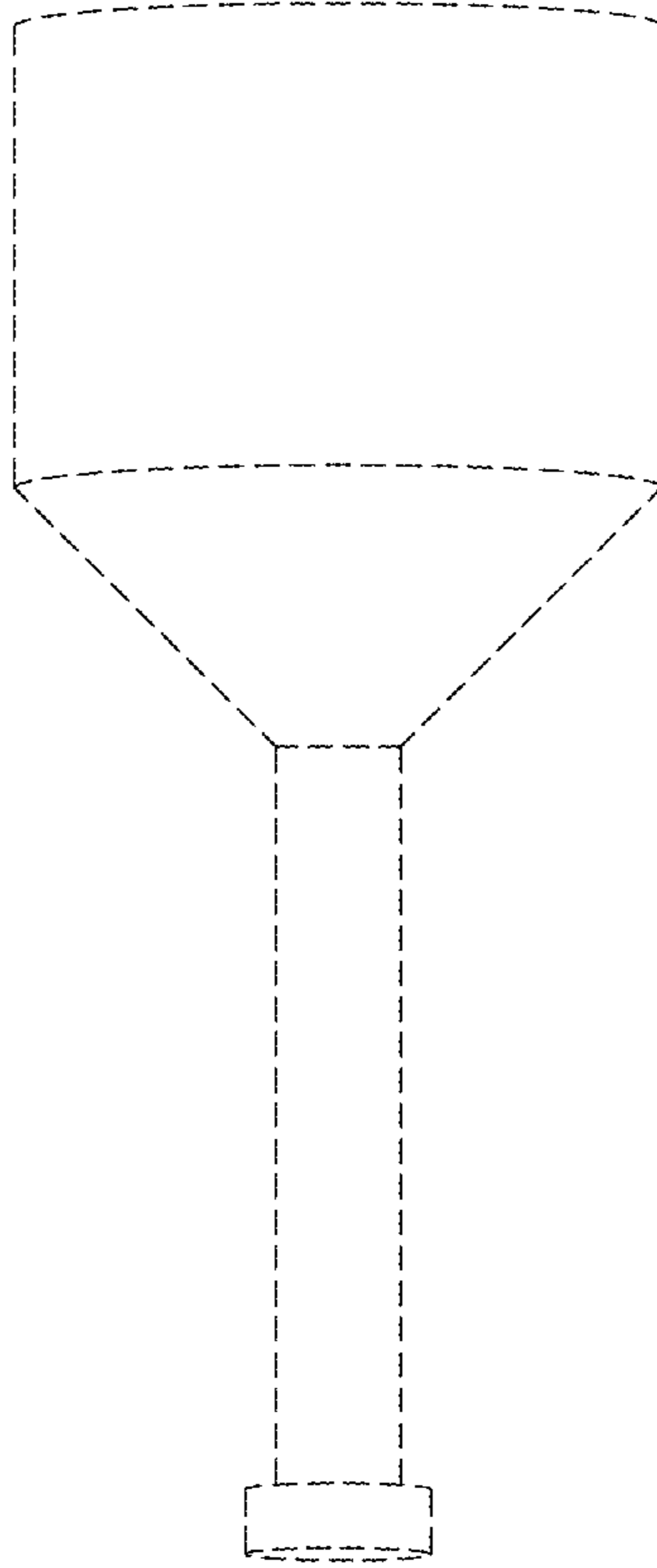

FIG. 1

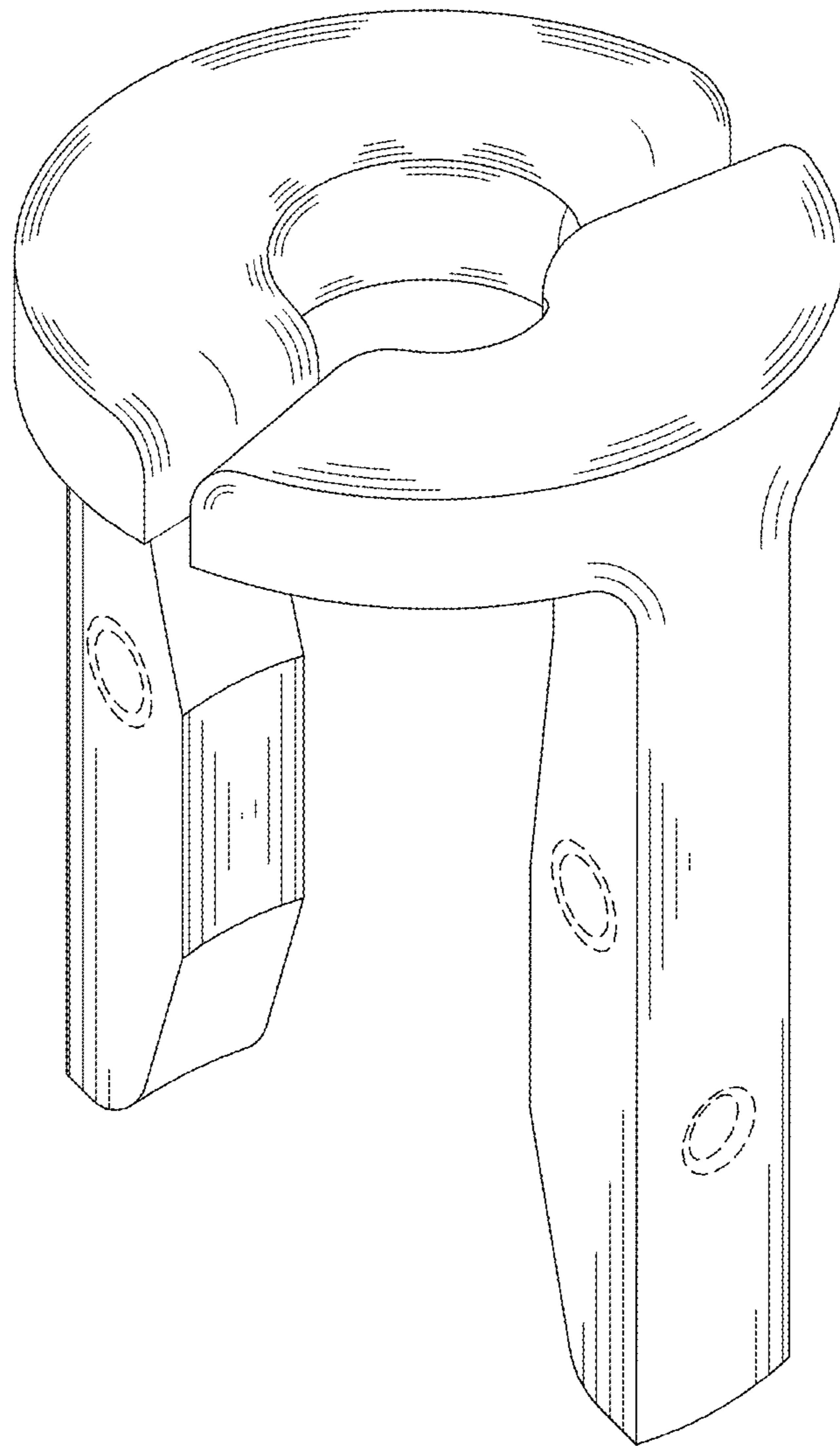

FIG. 2

FIG. 3

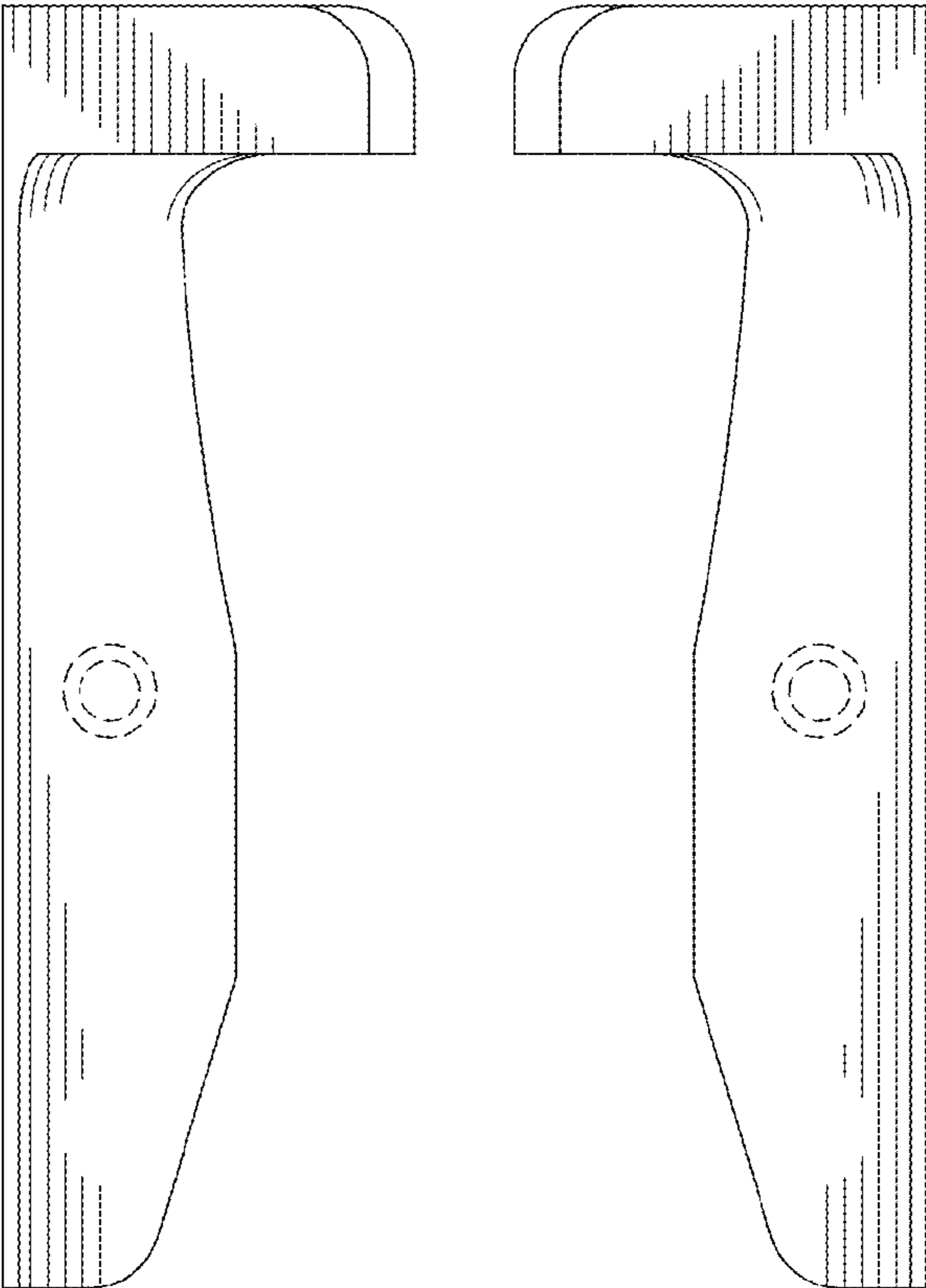
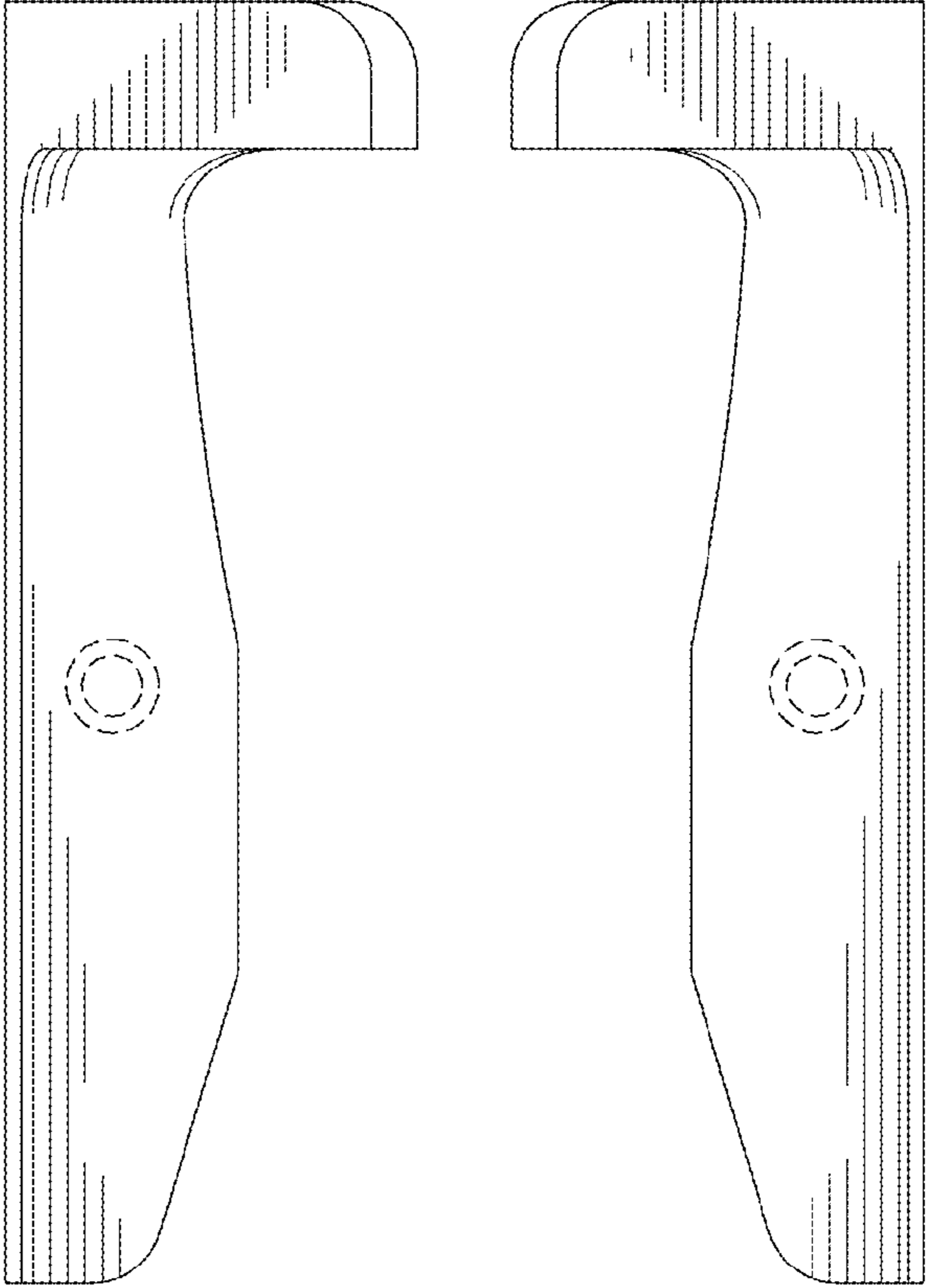

FIG. 4



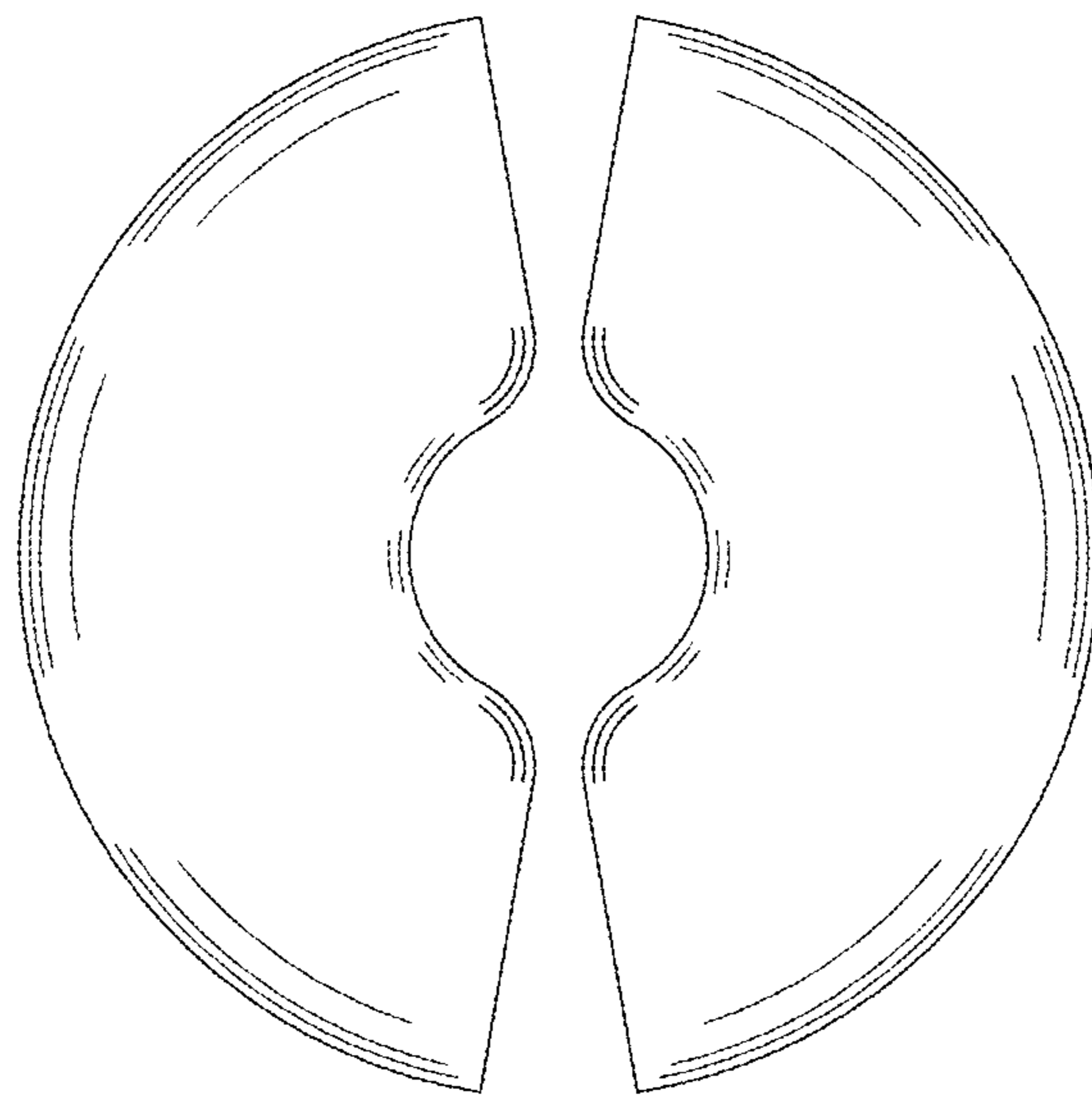

FIG. 5

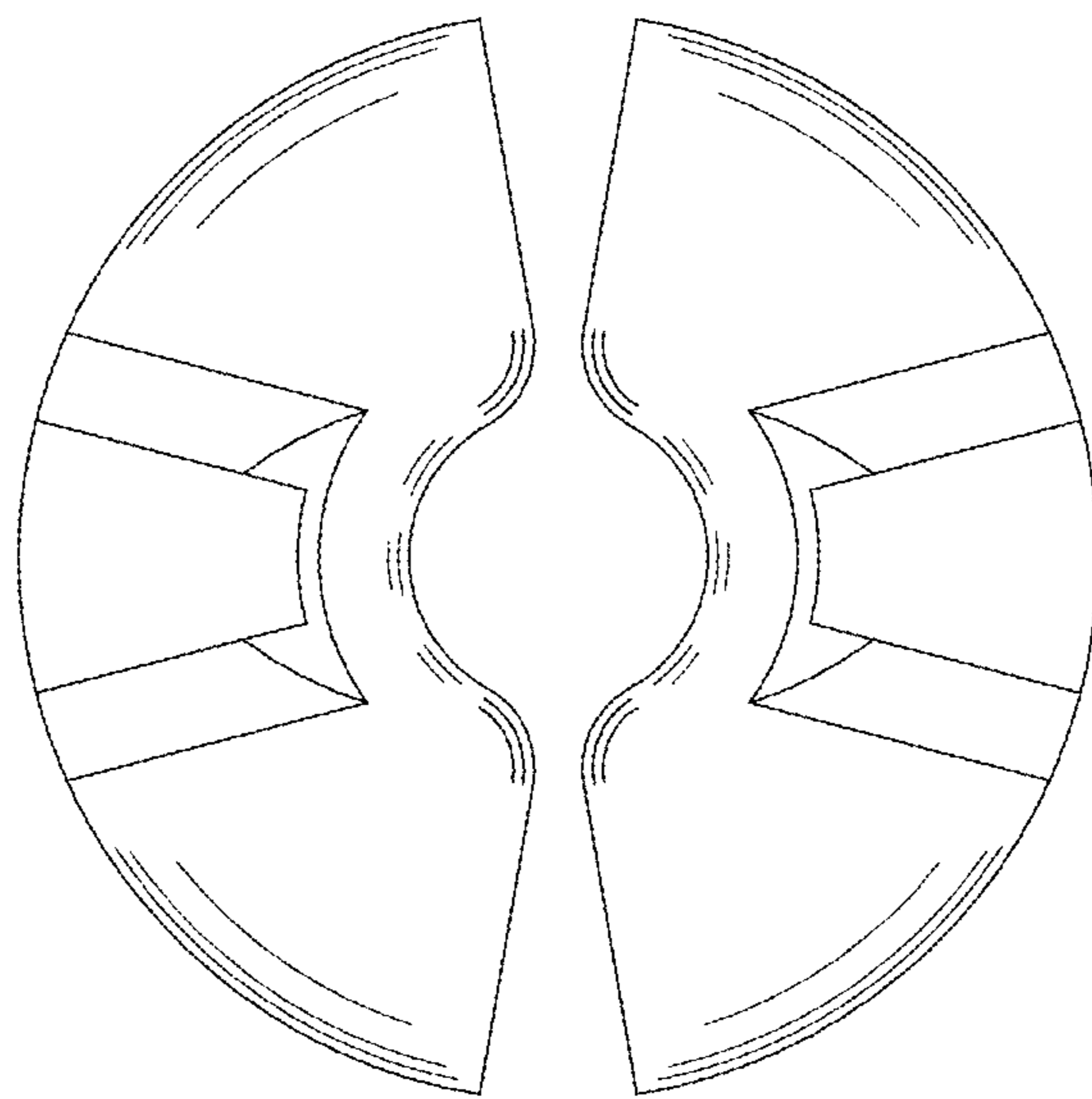

FIG. 6

FIG. 7

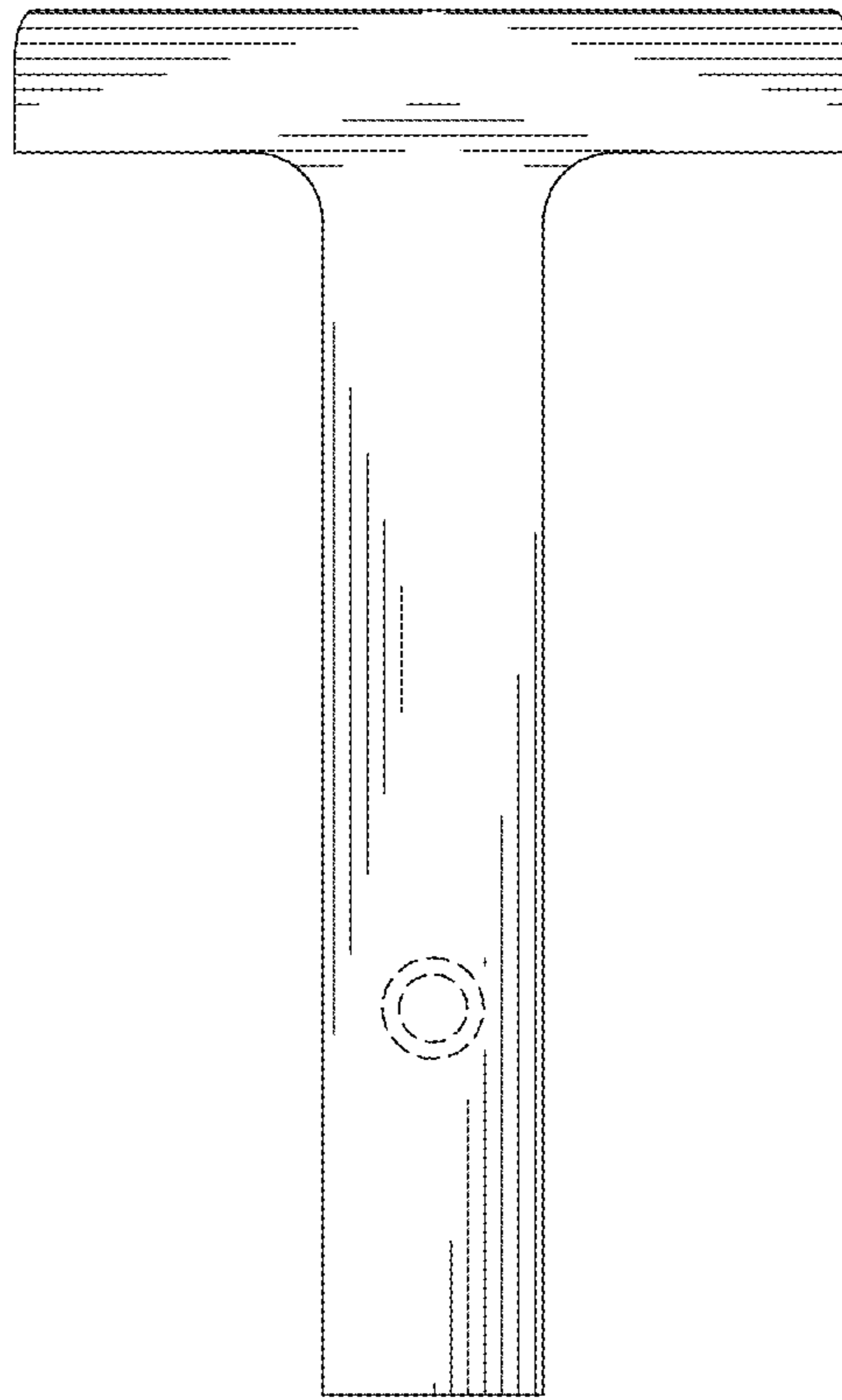
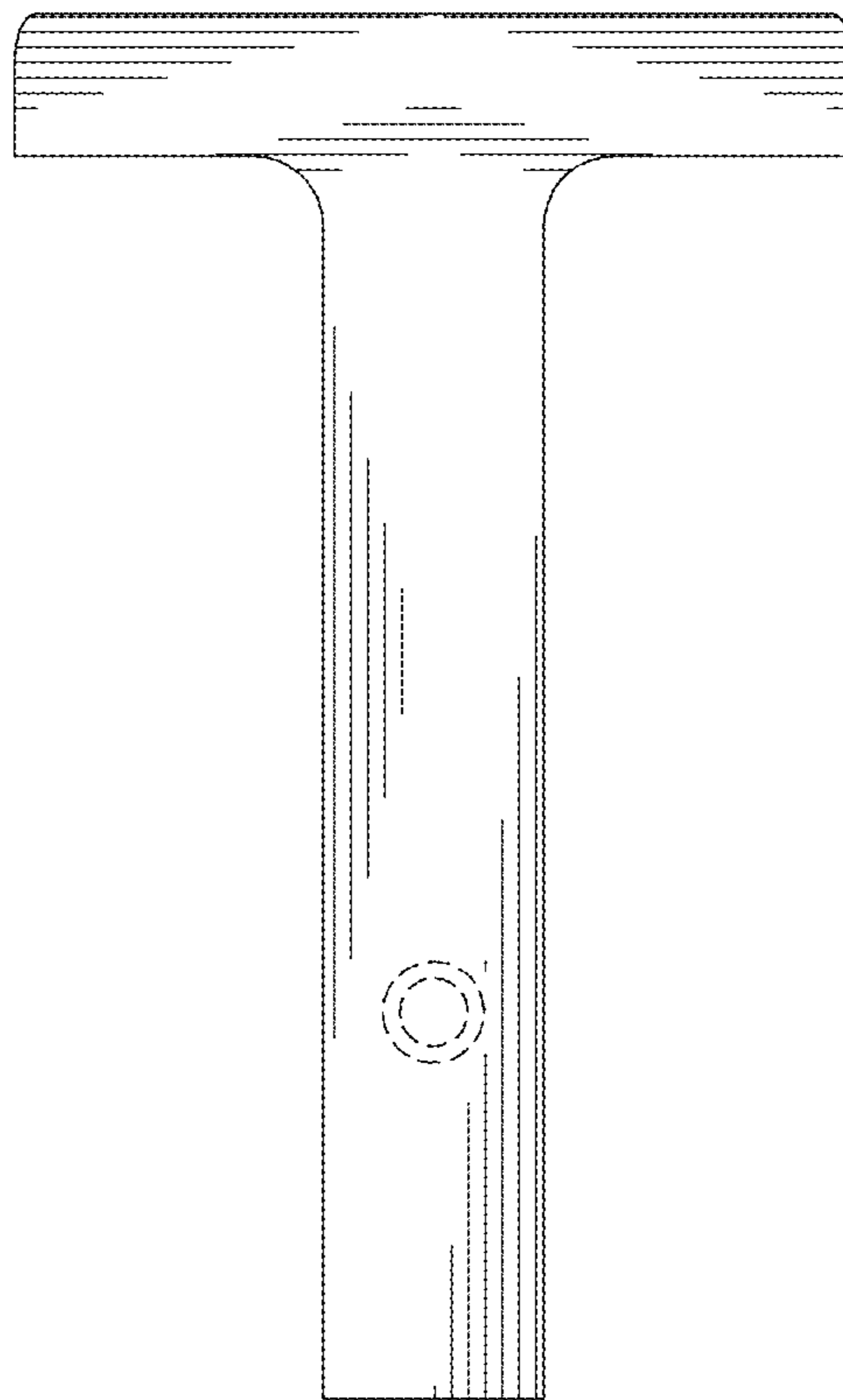

FIG. 8



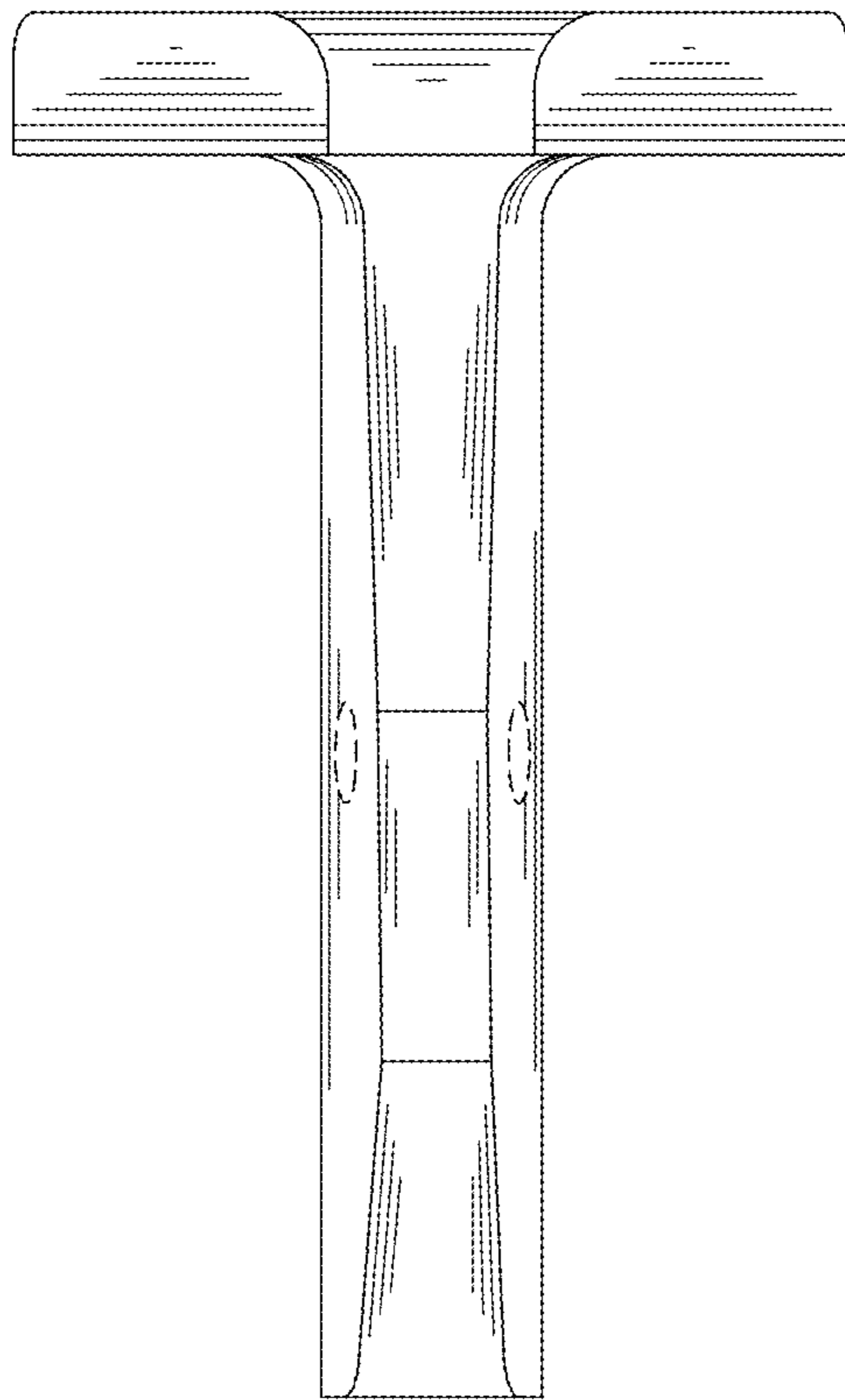

FIG. 9

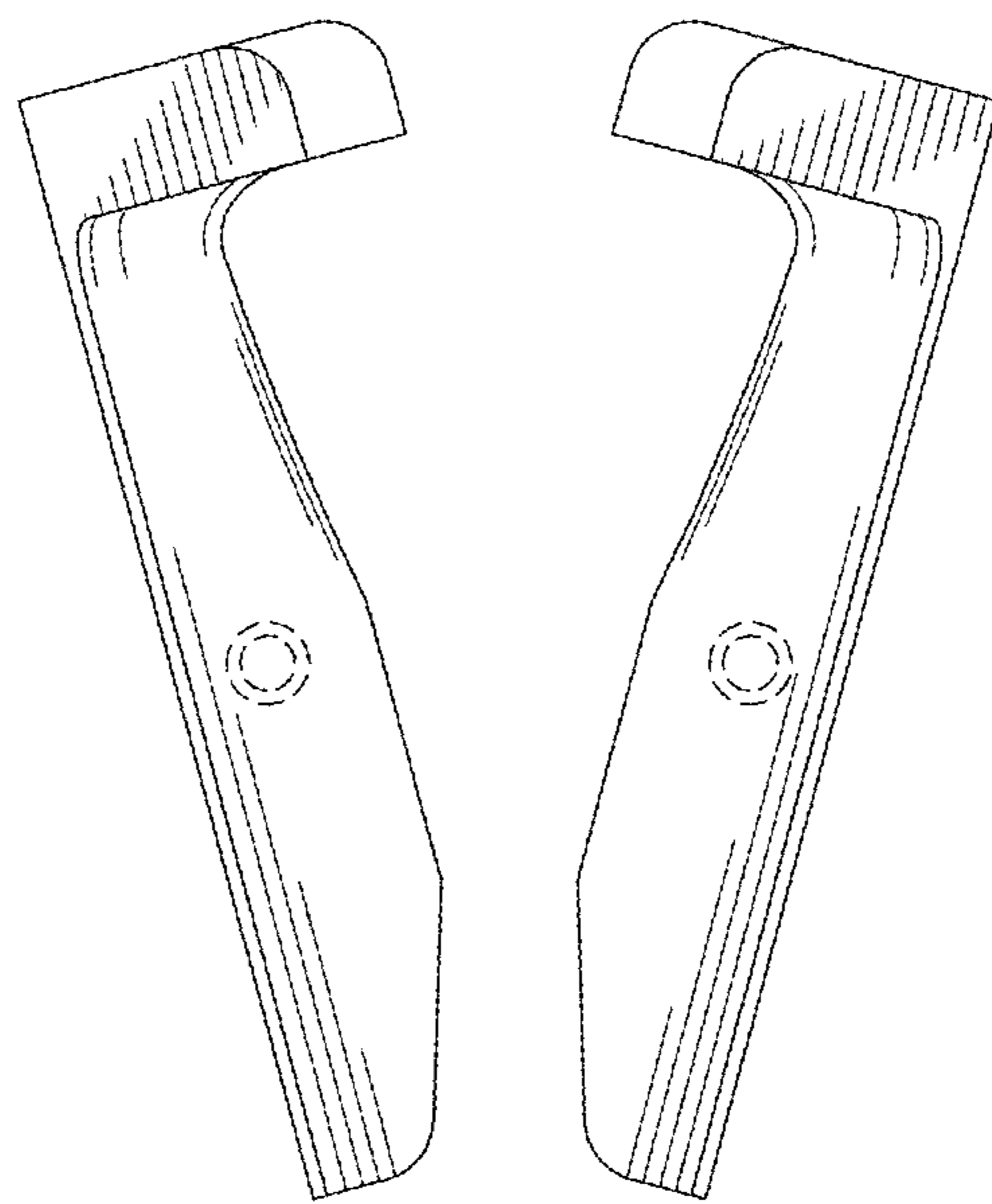
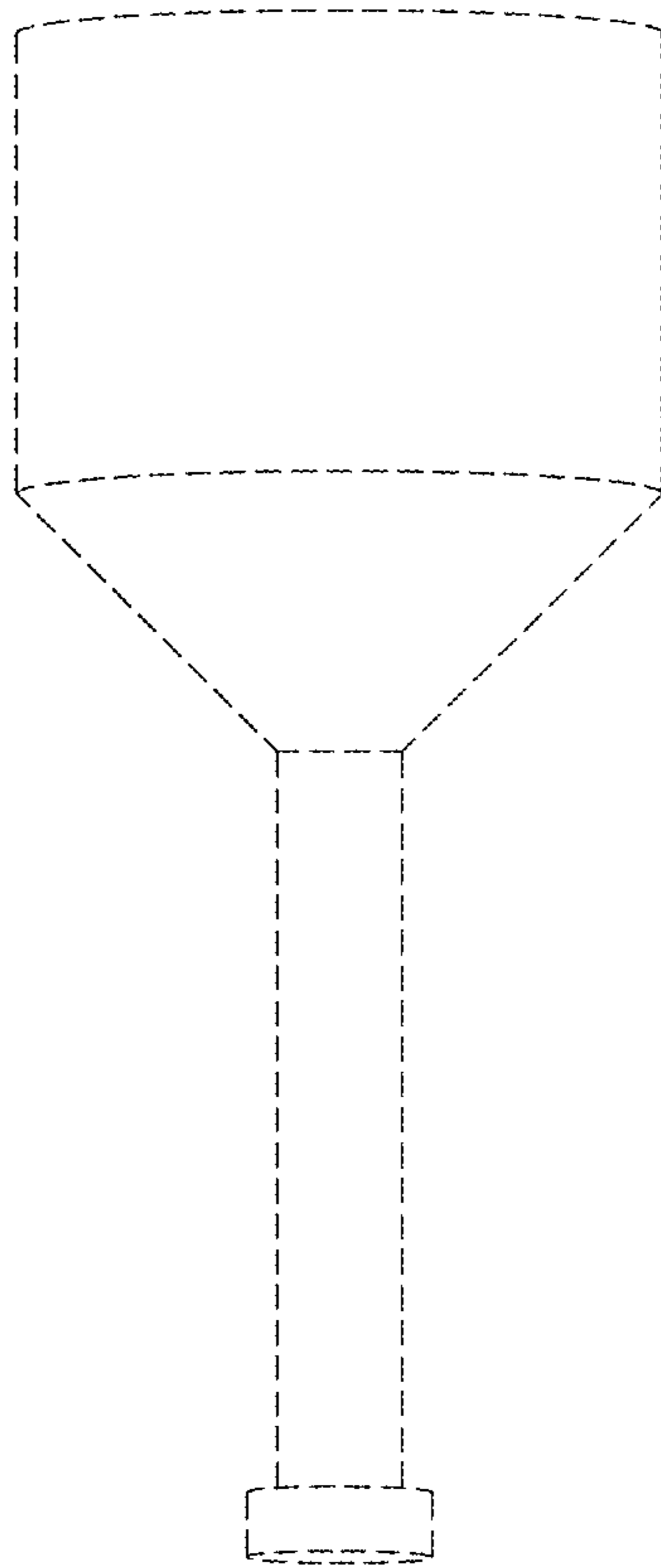

FIG. 10

FIG. 11

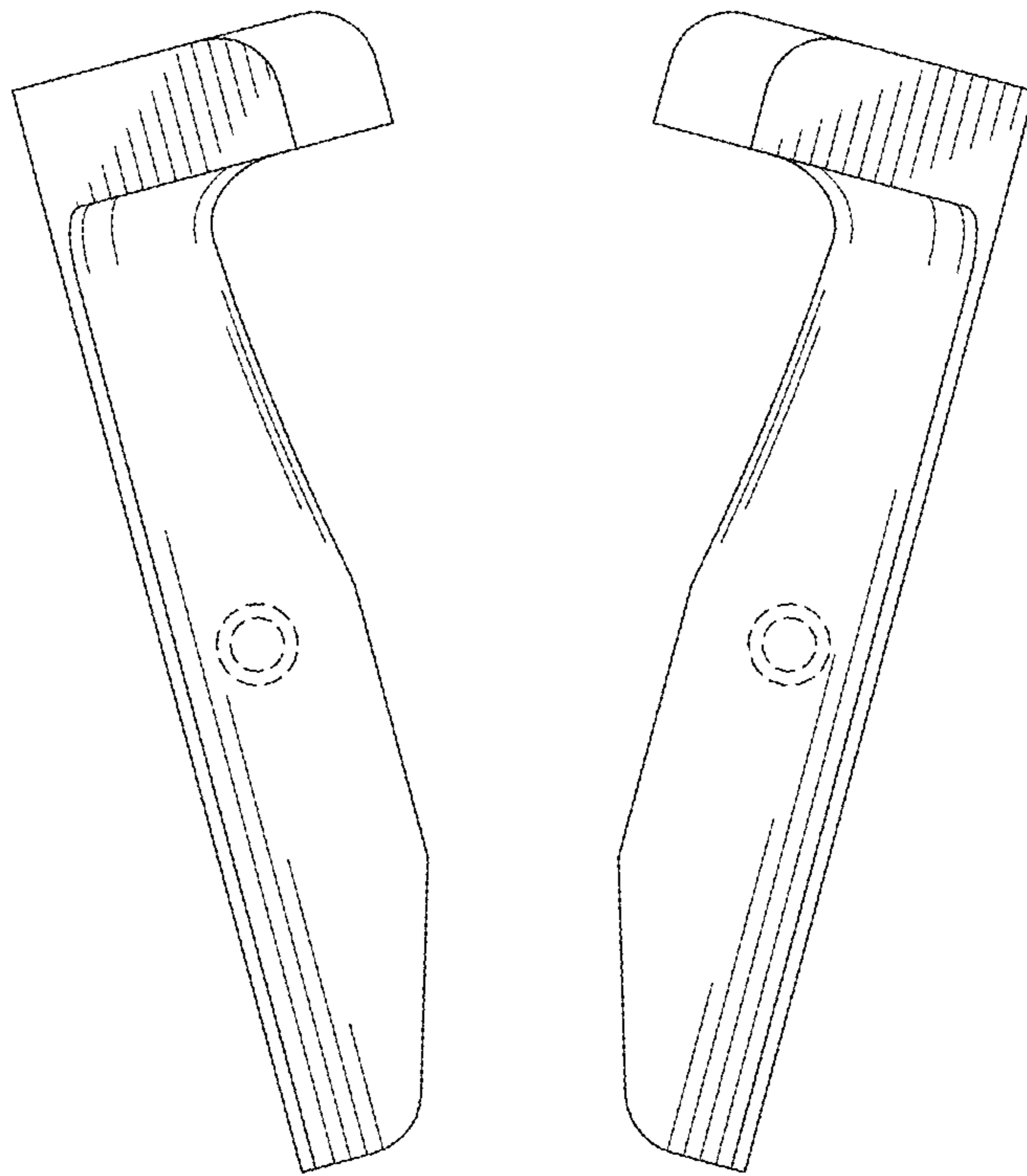
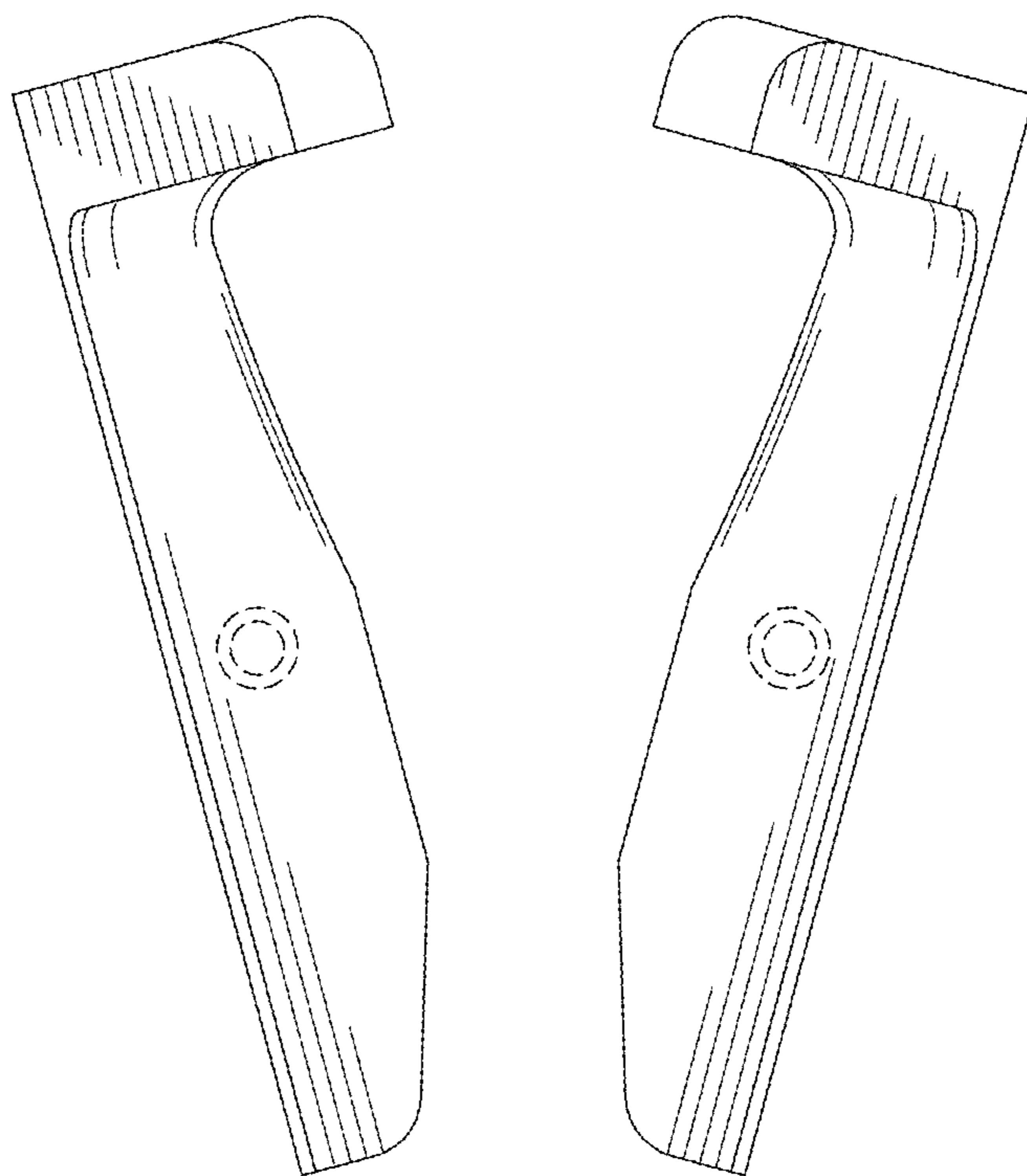

FIG. 12



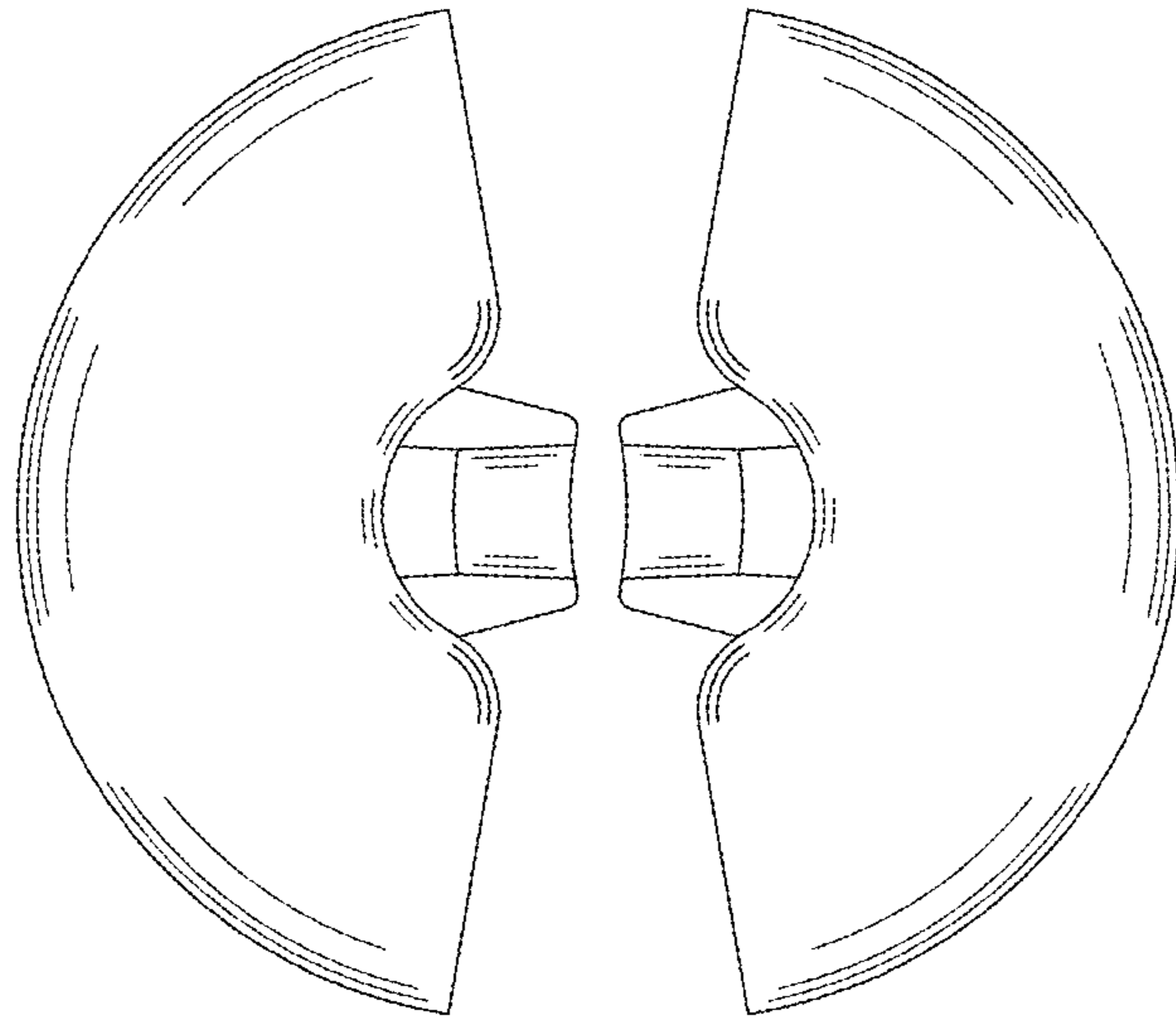

FIG. 13

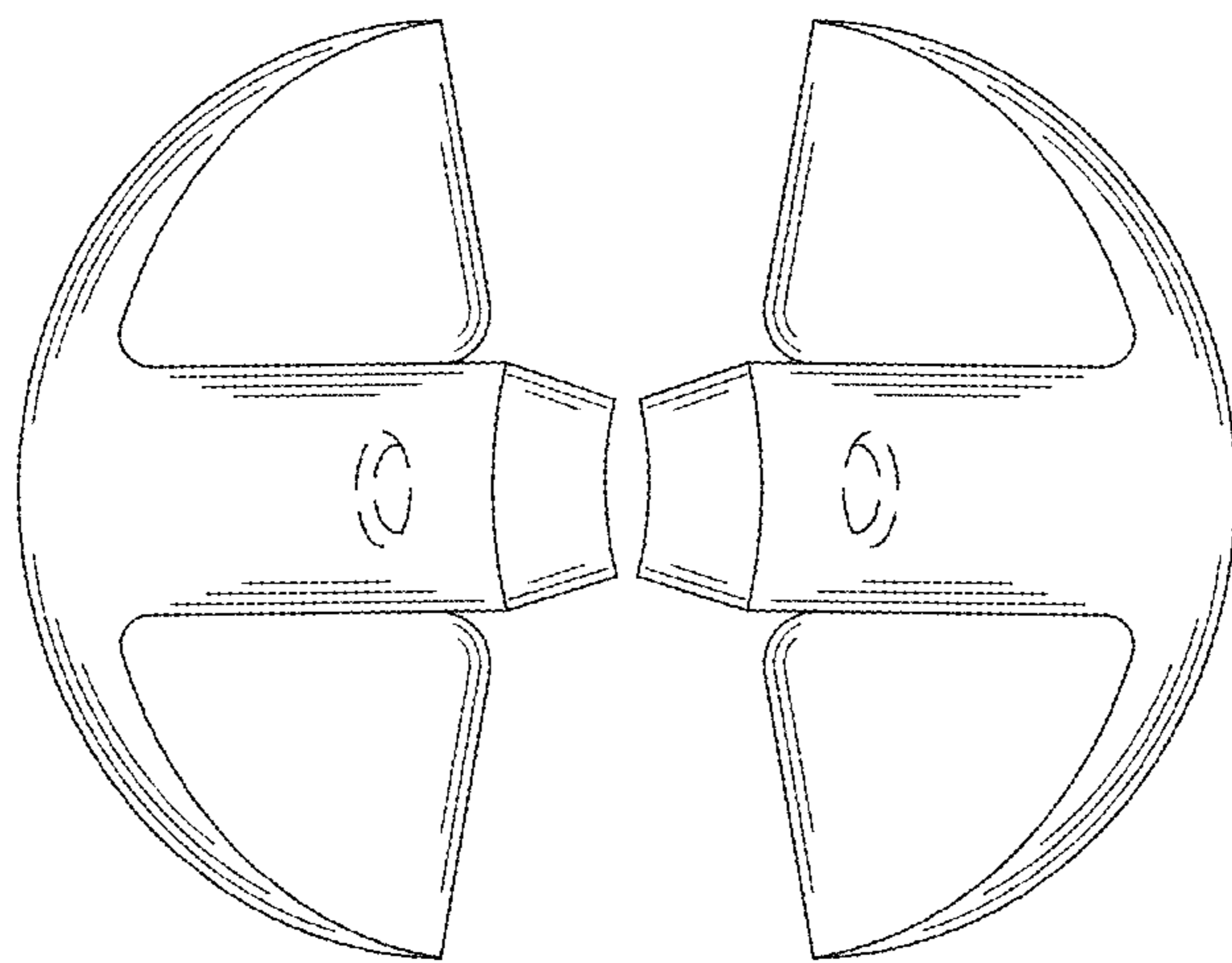

FIG. 14

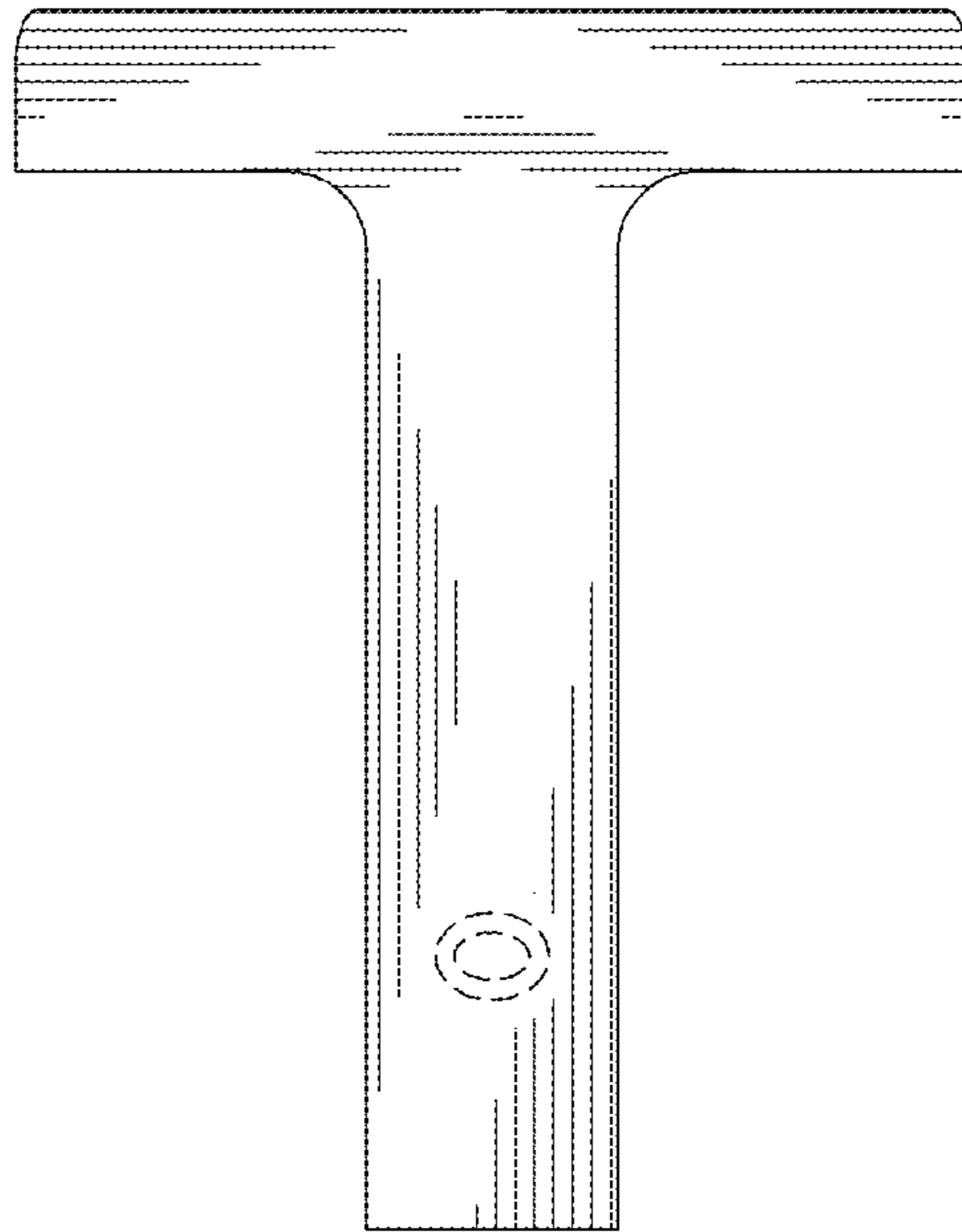

FIG. 15

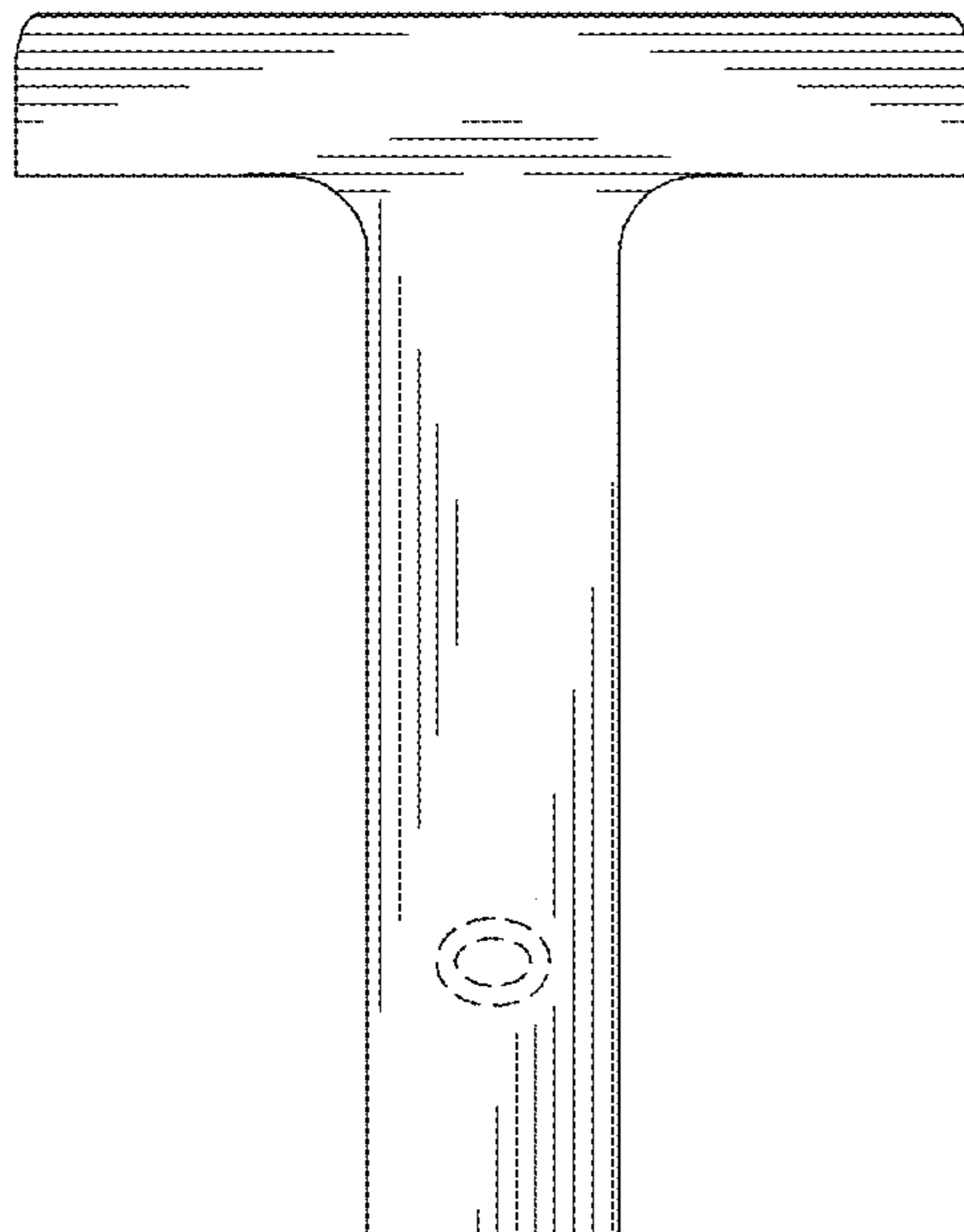

FIG. 16