



US00D882096S

(12) **United States Design Patent** (10) **Patent No.:** **US D882,096 S**  
**Dekock et al.** (45) **Date of Patent:** **\*\* Apr. 21, 2020**

(54) **ULTRASOUND PROBE**

FOREIGN PATENT DOCUMENTS

(71) Applicant: **FUJIFILM SonoSite, Inc.**, Bothell, WA (US)

EM 002290676-0004 \* 8/2013

(72) Inventors: **Ben Dekock**, Snohomish, WA (US);  
**Craig Chamberlain**, Seattle, WA (US);  
**Patrick Nally**, Seattle, WA (US);  
**James Arthur Young**, Snohomish, WA (US)

OTHER PUBLICATIONS

GE 6S-RS Cardiac Sector Probe. Online, published date unknown. Retrieved on Jun. 2, 2019 from URL: <https://www.kpihealthcare.com/medical-equipment/ultrasound-probes/ge-probes/ge-6s-rs-cardiac-sector-probe/>.\*

(73) Assignee: **FUJIFILM SONOSITE, INC.**, Bothell, WA (US)

\* cited by examiner

(\*\*) Term: **15 Years**

*Primary Examiner* — Susan Bennett Hattan  
*Assistant Examiner* — Omeed Agilee

(21) Appl. No.: **29/641,971**

(74) *Attorney, Agent, or Firm* — Womble Bond Dickinson (US) LLP

(22) Filed: **Mar. 26, 2018**

(51) **LOC (12) Cl.** ..... **24-02**

(57) **CLAIM**

(52) **U.S. Cl.**  
USPC ..... **D24/187**

The ornamental design for an ultrasound probe, as shown and described.

(58) **Field of Classification Search**  
USPC ..... D24/133, 137, 138, 141, 158, 160, 164,  
D24/165, 167, 170, 186, 187, 200;  
D10/57, 60, 78, 80  
CPC ... A61B 5/0095; A61B 8/4444; A61B 8/4455;  
G01S 7/5208

**DESCRIPTION**

See application file for complete search history.

(56) **References Cited**

U.S. PATENT DOCUMENTS

D390,959 S *	2/1998	Mesaros	.....	D24/186
D545,433 S *	6/2007	Messerly	.....	D24/158
D681,824 S *	5/2013	Shinohara	.....	D24/186
D703,332 S *	4/2014	Saeki	.....	D24/187
D703,821 S *	4/2014	Moon	.....	D24/187
D745,972 S *	12/2015	Kitayama	.....	D24/187
D749,224 S *	2/2016	Iritani	.....	D24/187
D770,629 S *	11/2016	Nieminen	.....	D24/187
D770,630 S *	11/2016	Nieminen	.....	D24/187
D811,607 S *	2/2018	Kitayama	.....	D24/187
D831,219 S *	10/2018	Henderson	.....	D24/187
D842,482 S *	3/2019	Harada	.....	D24/187

FIG. 1 is a right rear isometric view of an ultrasound probe showing our new design; FIG. 2 is a left rear isometric view thereof; FIG. 3 is a right side elevation view thereof; FIG. 4 is a left-side elevation view thereof; FIG. 5 is a front elevation view thereof; FIG. 6 is a rear elevation view thereof; FIG. 7 is a top plan view thereof; and, FIG. 8 is a bottom plan view thereof. The dash-dot-dash broken lines and the dashed lines on the right side of the ultrasound probe adjacent to the shaded areas depict boundaries of the claim and form no part thereof. All other dashed lines in the drawings depict portions of the ultrasound probe that form no part of the claimed design.

**1 Claim, 5 Drawing Sheets**

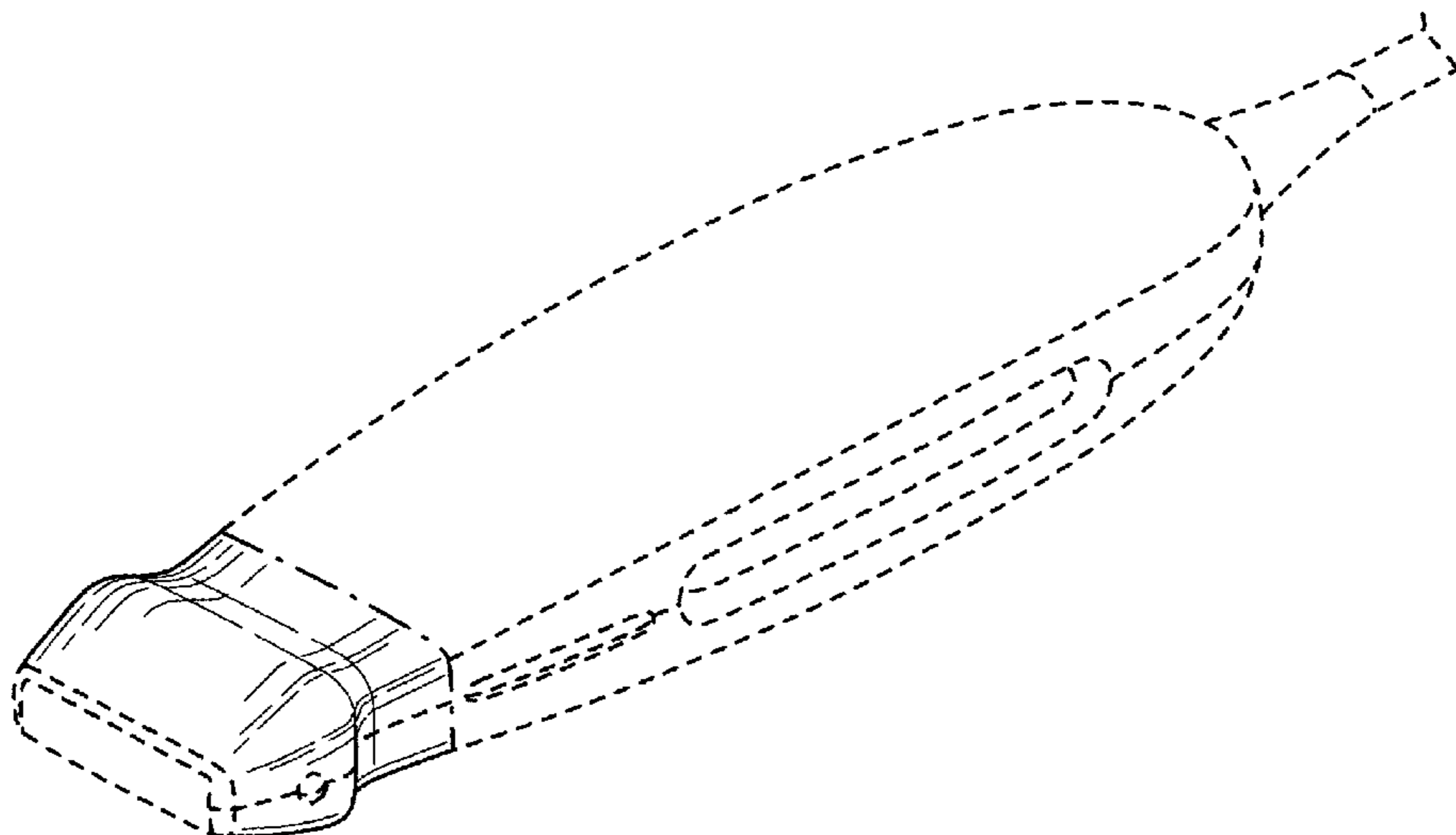

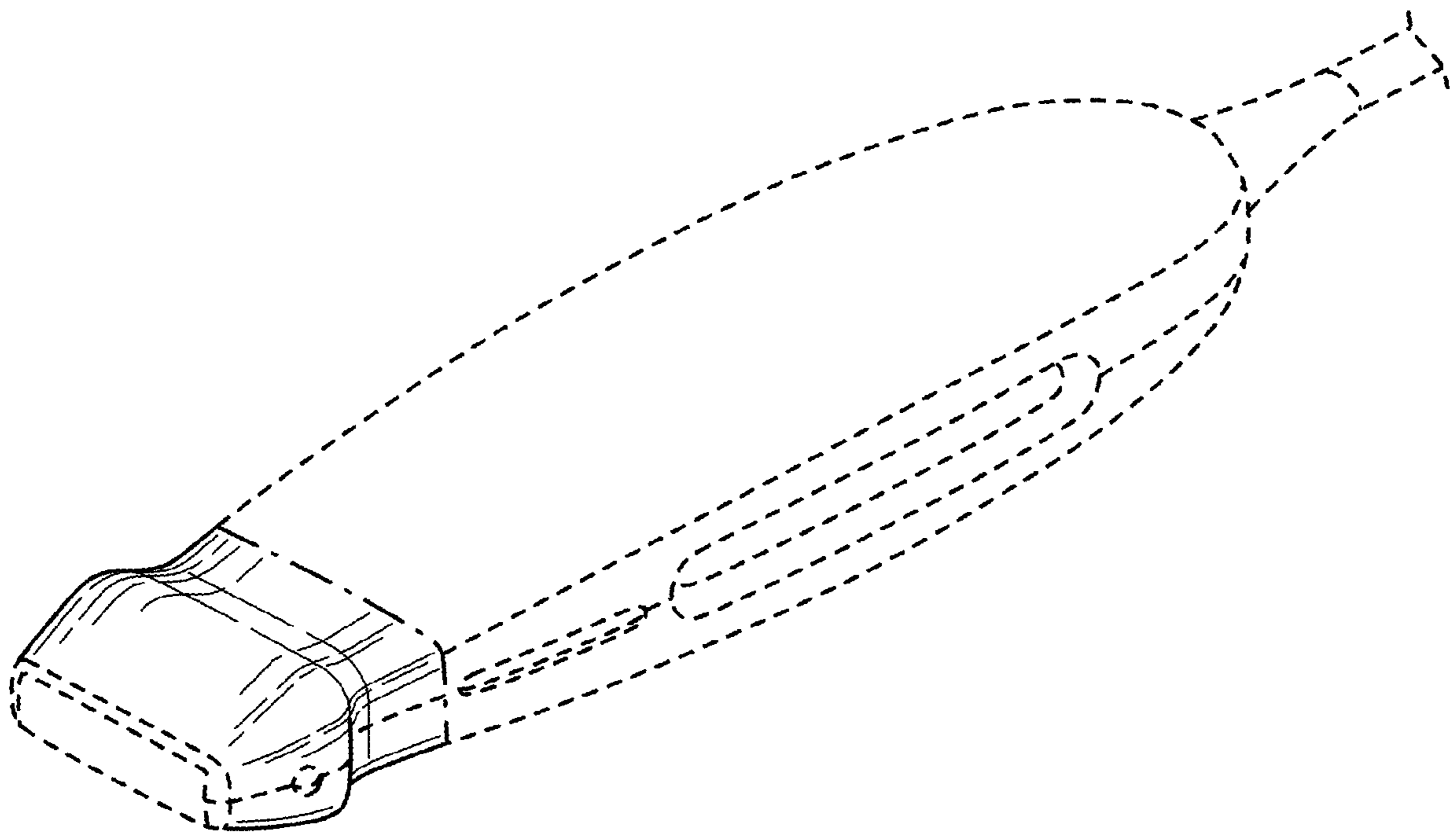

FIG. 1

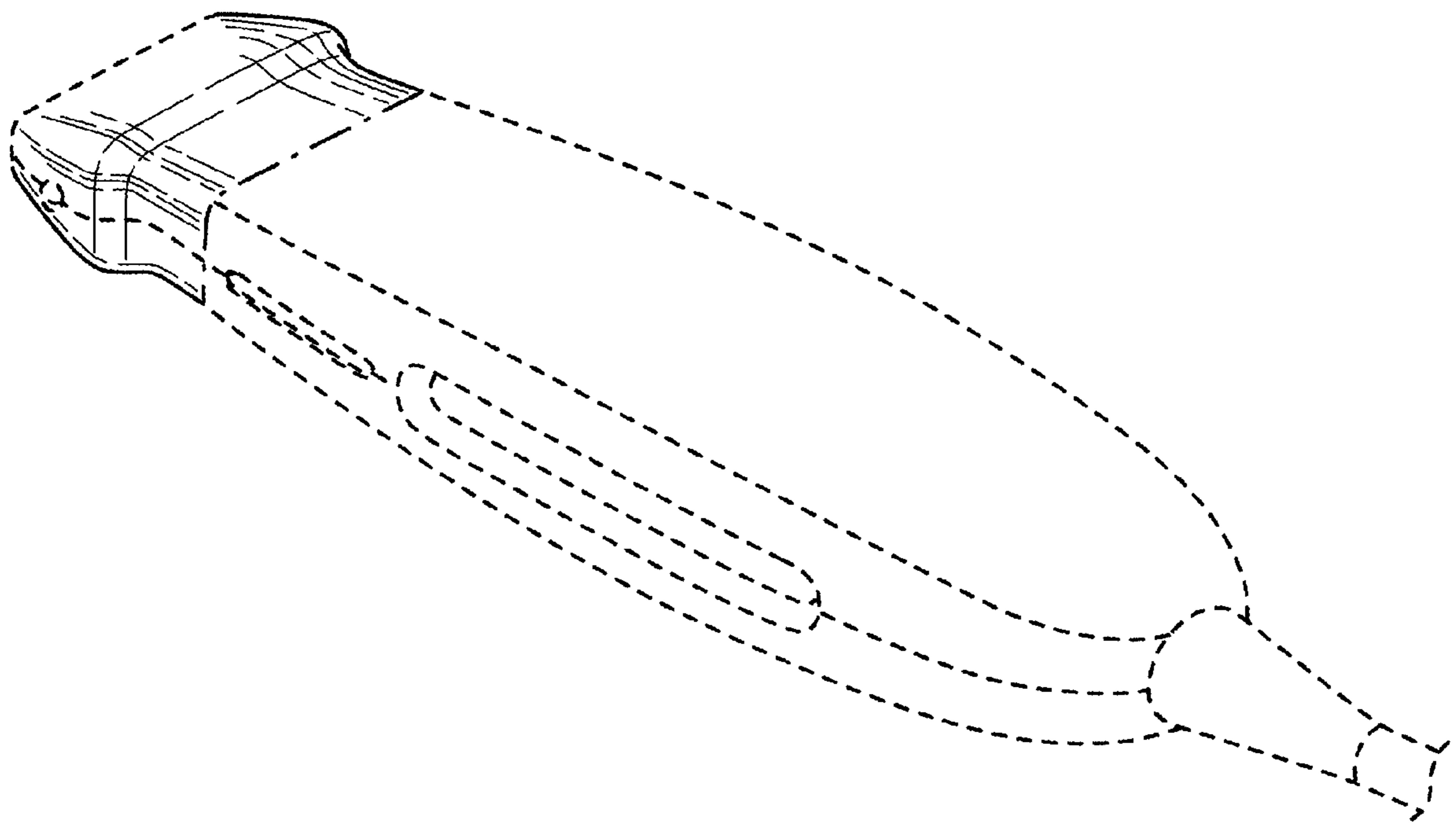

FIG. 2

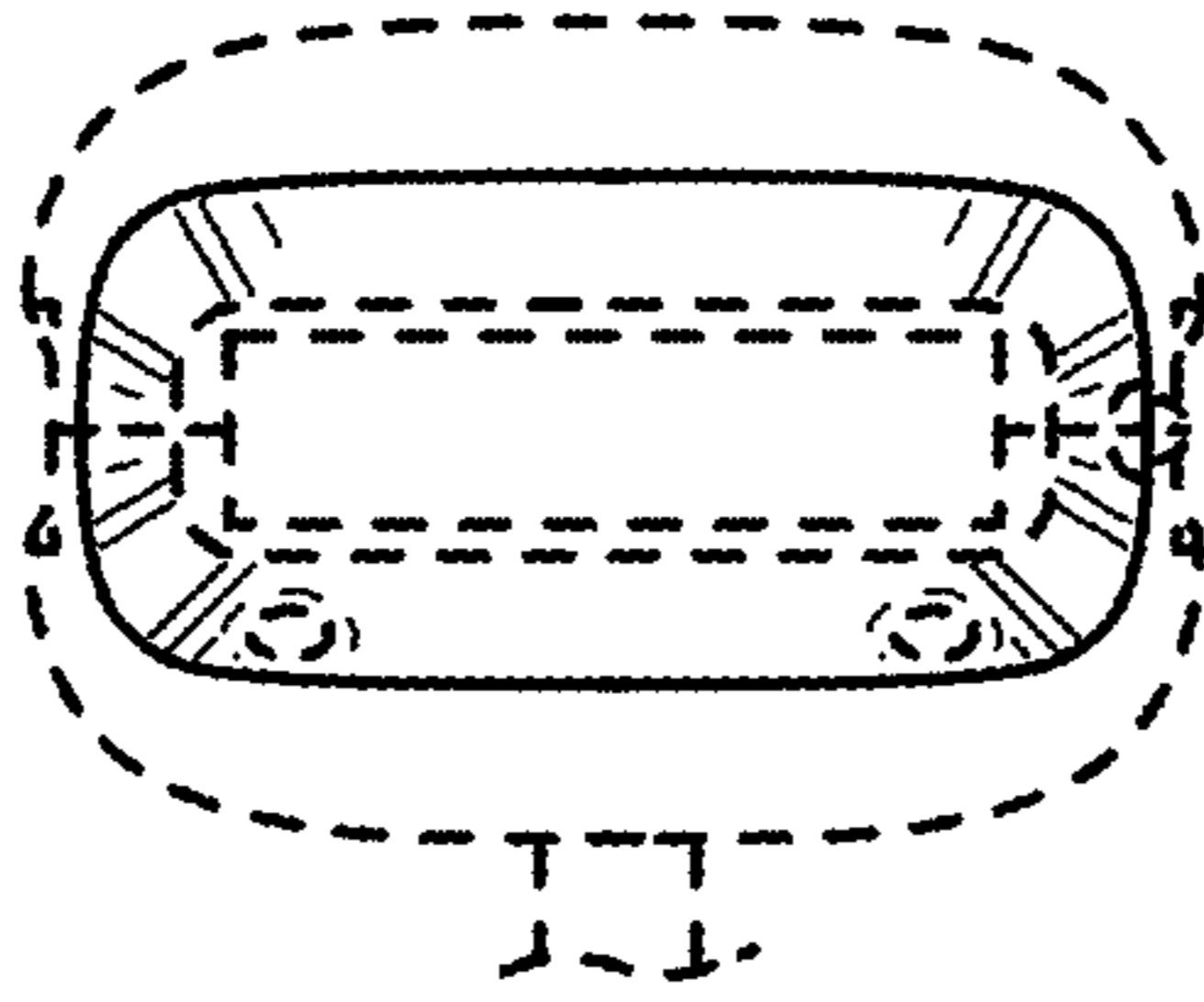

FIG. 3

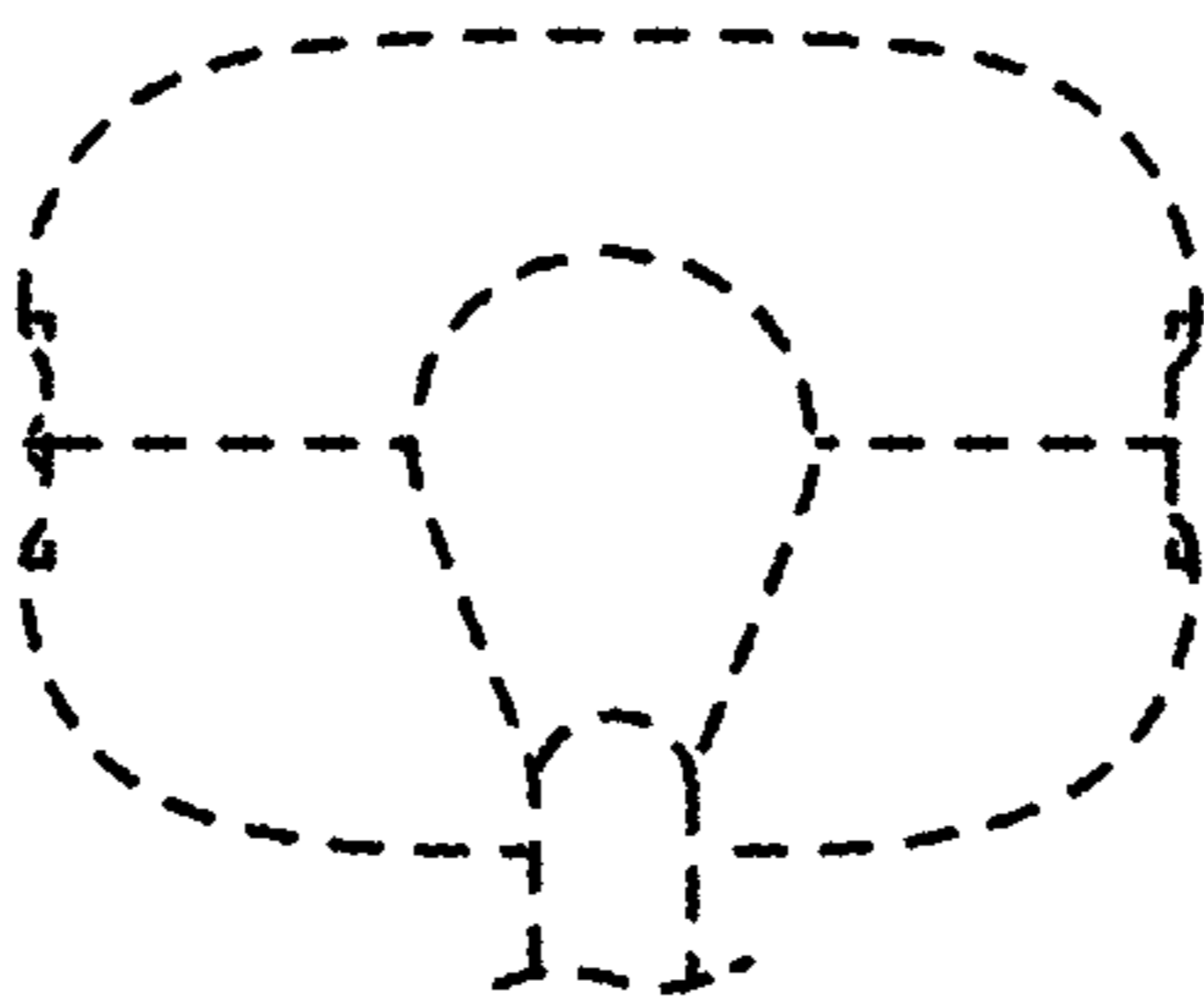

FIG. 4

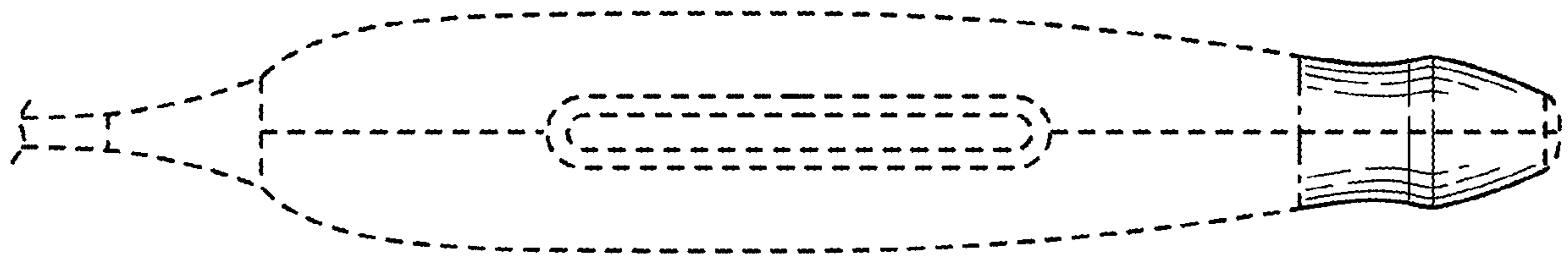

FIG. 5

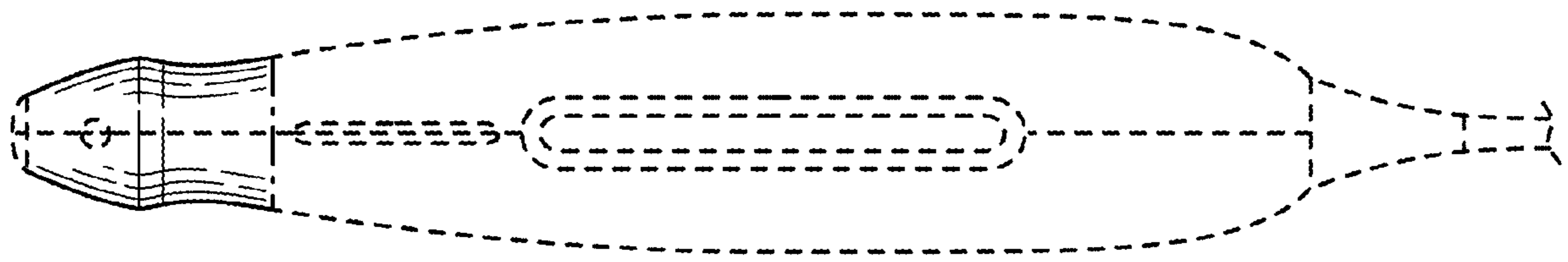

FIG. 6



FIG. 7



FIG. 8