



US00D881959S

(12) **United States Design Patent**  
**Karol et al.**

(10) **Patent No.:** **US D881,959 S**  
(45) **Date of Patent:** **\*\* Apr. 21, 2020**

- (54) **GEAR**
- (71) Applicant: **DEKA Products Limited Partnership**,  
Manchester, NH (US)
- (72) Inventors: **Daniel S. Karol**, Southborough, MA  
(US); **William D. Hunt**, Gilmanton,  
NH (US); **Jason M. Overson**,  
Manchester, NH (US)
- (73) Assignee: **DEKA Products Limited Partnership**,  
Manchester, NH (US)

2,859,634 A \* 11/1958 Gustave ..... B63H 23/00  
440/75  
3,176,597 A \* 4/1965 Seaman ..... E01C 19/282  
404/117  
3,490,360 A \* 1/1970 Reynolds ..... B65B 13/18  
100/31  
D253,641 S 12/1979 Tritchka  
4,545,230 A \* 10/1985 Jungesjo ..... B21H 5/02  
72/108  
4,630,498 A 12/1986 Santi  
5,137,500 A 8/1992 Lhotak  
(Continued)

- (\*\*) Term: **15 Years**
- (21) Appl. No.: **29/657,800**
- (22) Filed: **Jul. 25, 2018**

FOREIGN PATENT DOCUMENTS

EP 1669254 A1 6/2006  
JP 2002021981 A 1/2002  
(Continued)

**Related U.S. Application Data**

- (62) Division of application No. 29/572,419, filed on Jul.  
27, 2016, now Pat. No. Des. 824,971.
- (51) **LOC (12) Cl.** ..... **15-99**
- (52) **U.S. Cl.**  
USPC ..... **D15/148**
- (58) **Field of Classification Search**  
USPC ..... D12/123, 124, 126, 501, 507; D15/122,  
D15/138, 143, 148, 149  
CPC ... F16H 7/06; F16H 7/12; F16H 55/08; F16H  
55/30; E02F 5/06; E02F 5/14  
See application file for complete search history.

OTHER PUBLICATIONS

US D847,887 S, 05/2019, Karol (withdrawn)\*  
(Continued)

*Primary Examiner* — Michael C Stout  
*Assistant Examiner* — Fritzgerald L Butac  
(74) *Attorney, Agent, or Firm* — Kathleen Chapman

(56) **References Cited**

U.S. PATENT DOCUMENTS

1,385,144 A \* 7/1921 Myers ..... F04B 13/00  
184/11.1  
2,791,911 A \* 5/1957 Wasko ..... B22C 9/06  
474/154  
2,811,819 A \* 11/1957 Heth ..... A01D 82/00  
100/70 A

**CLAIM**

The ornamental design for a gear, as shown and described.

**DESCRIPTION**

FIG. 1 is a front, top, right side perspective view of a gear,  
showing our new design;  
FIG. 2 is a front side elevational view thereof;  
FIG. 3 is a rear side elevational view thereof;  
FIG. 4 is a left side elevational view thereof;  
FIG. 5 is a right side elevational view thereof;  
FIG. 6 is a top plan view thereof; and,  
FIG. 7 is a bottom plan view thereof.

**1 Claim, 5 Drawing Sheets**

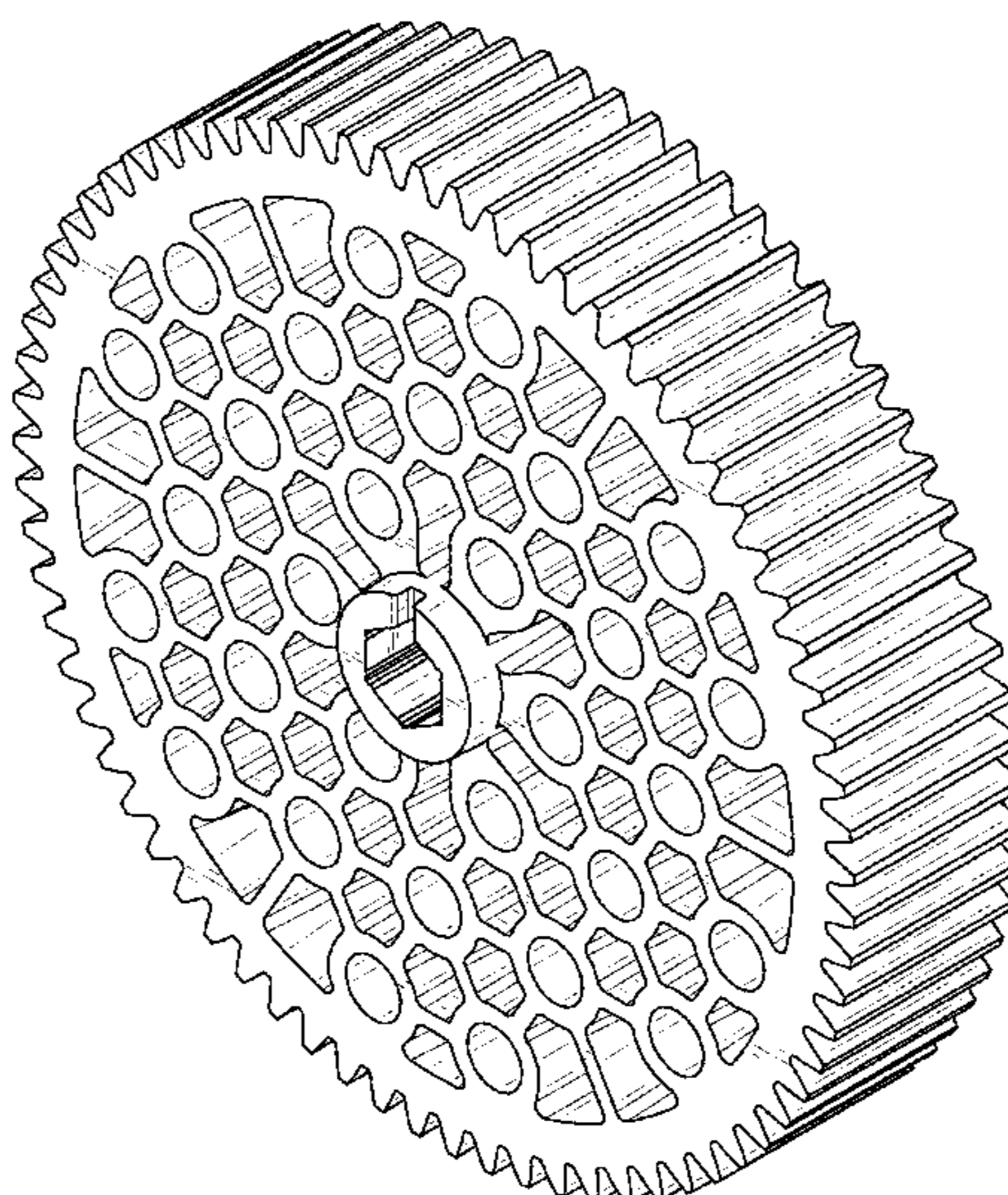

(56)

References Cited

U.S. PATENT DOCUMENTS

D330,052 S 10/1992 Klitsner  
 5,194,031 A 3/1993 Sahler  
 5,251,711 A \* 10/1993 Meyer ..... A47L 5/28  
 180/19.1  
 D349,736 S 8/1994 Hatting  
 D358,545 S 5/1995 Price  
 D364,199 S 11/1995 Schmidt  
 D366,073 S 1/1996 Schmidt  
 D382,463 S 8/1997 Cloud  
 D388,475 S 12/1997 Glickman  
 D395,469 S 6/1998 Glickman  
 D396,436 S \* 7/1998 Liska ..... D12/123  
 D399,222 S 10/1998 Chang  
 D402,995 S \* 12/1998 Hakamata ..... D15/148  
 D402,996 S \* 12/1998 Watanabe ..... D15/148  
 5,926,673 A 7/1999 Foster  
 D434,351 S 11/2000 Takamori  
 D435,001 S 12/2000 Takamori  
 D436,561 S 1/2001 Louden  
 D442,200 S 5/2001 Koch  
 D443,880 S 6/2001 Iida  
 6,283,076 B1 9/2001 Simpson  
 D451,526 S 12/2001 Lee  
 D453,214 S 1/2002 Komatsubara  
 D470,861 S 2/2003 Kohno  
 D470,862 S 2/2003 Kohno  
 D472,843 S 4/2003 Marquez-Pickering  
 D473,902 S 4/2003 Panno  
 D482,847 S 12/2003 Lee  
 6,722,221 B2 \* 4/2004 Maxwell ..... F01L 1/02  
 474/902  
 D498,775 S 11/2004 Hu  
 D498,777 S 11/2004 Hu  
 D498,778 S 11/2004 Hu  
 6,910,980 B2 6/2005 Hamilton  
 D519,031 S 4/2006 Snyder  
 D527,245 S 8/2006 Kellegan  
 D527,738 S 9/2006 Pearson, Sr.  
 D558,006 S 12/2007 Tuan Mu  
 D559,080 S 1/2008 Boote  
 D561,793 S 2/2008 Kanemitsu  
 7,344,463 B2 3/2008 Reiter  
 D585,345 S 1/2009 Maier  
 D604,346 S 11/2009 Chiang  
 D611,391 S 3/2010 Bourgeois  
 D618,720 S 6/2010 Wasai  
 D618,721 S 6/2010 Wasai  
 7,914,408 B2 3/2011 Young  
 D641,611 S \* 7/2011 Minayoshi ..... D8/354  
 D647,118 S 10/2011 Parker  
 D667,049 S 9/2012 Park  
 D668,527 S \* 10/2012 Noumi ..... D8/356  
 D670,304 S 11/2012 Shimozaki  
 D670,305 S \* 11/2012 Shimozaki ..... D14/483  
 D675,130 S \* 1/2013 Senn ..... D12/42  
 D677,718 S 3/2013 Huck  
 D683,099 S 5/2013 Wright  
 D696,342 S 12/2013 Lewis  
 D706,340 S 6/2014 Lee  
 D728,432 S 5/2015 Lin  
 9,033,835 B2 5/2015 Blank  
 D738,439 S 9/2015 Kanbar  
 D750,676 S 3/2016 Brown  
 D757,832 S 5/2016 Calcino  
 D765,551 S 9/2016 Baker, Jr.  
 D774,987 S 12/2016 Miles  
 D776,896 S 1/2017 Paitchell  
 D779,587 S 2/2017 Li  
 D779,618 S 2/2017 Farthing  
 D781,345 S 3/2017 Pratley  
 D787,380 S 5/2017 Karol  
 D789,436 S 6/2017 McCurry  
 D802,037 S 11/2017 Cordingley  
 D802,039 S 11/2017 Cordingley  
 D806,614 S 1/2018 Turner

D811,948 S 3/2018 Turner  
 D815,675 S 4/2018 Karol  
 D816,136 S 4/2018 Karol et al.  
 D817,371 S 5/2018 Karol  
 D817,372 S 5/2018 Karol  
 D818,015 S 5/2018 Karol  
 D824,971 S 8/2018 Karol et al.  
 D824,972 S 8/2018 Karol  
 D825,631 S 8/2018 Karol et al.  
 D828,235 S 9/2018 Kittrel, Jr. et al.  
 D829,627 S 10/2018 Hunt  
 D847,886 S \* 5/2019 Karol ..... D15/148  
 D860,279 S 9/2019 Karol et al.  
 D866,296 S \* 11/2019 Ohse ..... D8/354  
 D867,953 S \* 11/2019 Hunt ..... D12/204  
 D877,220 \* 3/2020 Karol ..... D15/148  
 2002/0064447 A1 5/2002 Gurevich  
 2003/0168291 A1 9/2003 Sneed  
 2008/0176688 A1 7/2008 Sakura  
 2008/0220689 A1 9/2008 Mimlitch  
 2009/0080936 A1 3/2009 Parisi  
 2010/0196047 A1 8/2010 Jin  
 2012/0045247 A1 2/2012 Lewis  
 2012/0183331 A1 7/2012 Huang  
 2012/0256471 A1 10/2012 Scogna  
 2013/0306925 A1 11/2013 Cozza  
 2015/0130260 A1 5/2015 Bando  
 2017/0210164 A1 7/2017 Mjelde  
 2017/0210437 A1 7/2017 Black  
 2017/0297366 A1 10/2017 Parrott et al.

FOREIGN PATENT DOCUMENTS

JP 2007309488 A 11/2007  
 WO WO 2007041291 A1 4/2007

OTHER PUBLICATIONS

#25 Sprockets—VEX Robotics, <http://www.vexrobotics.com/25-sprockets.html>, Innovation First International, Inc. © 2002-2016.  
 #35 Sprockets—VEX Robotics, <http://www.vexrobotics.com/35-sprockets.html>, Innovation First International, Inc. © 2002-2016.  
 1.125" Bearing Bore Gears—VEX Robotics, <http://www.vexrobotics.com/bearing-bore-gears.html>, Innovation First International, Inc. Copyright © 2002-2016.  
 AndyMark, Gears Search—Andy Mark Inc. (<http://www.andymark.com>) <http://www.andymark.com/Gears-s/85.htm> © 2017 AndyMark, Inc.  
 AndyMark, Sprocket Search—AndyMark Inc. (<http://www.andymark.com>) <http://www.andymark.com/Search-s/545.htm?Search=sprocker&Submit=© 2017 AndyMark, Inc.>  
 AndyMark, Wheel Search—AndyMark Inc. (<http://www.andymark.com>) <http://www.andymark.com/Search-s/545.htm?Search=wheel&Submit=© 2017 AndyMark, Inc.>  
 AP Table Chain Gear Assembly, posted on [brunswickbowling.com](http://brunswickbowling.com), no posted date given, no production date given, [online], [site visited May 11, 2017], Available from Internet, <URL: <http://www.brunswickbowling.com/products/parts/gs-pinsetter/detail/table-chain-gear-assembly/>>.  
 Ball Shifter & Dog Gears—VEX Robotics, <http://www.vexrobotics.com/shifter-gears.html>, Innovation First International, Inc. Copyright © 2002-2016.  
 Camshaft Sprocket Chain Drive, posted on [dlbensinger.com](http://dlbensinger.com), no posted date given, no production date given, [online], [site visited May 11, 2017], Available from Internet <URL: [https://www.dlbensinger.com/product\\_info.php?manufacturers\\_id=10&products\\_id=796](https://www.dlbensinger.com/product_info.php?manufacturers_id=10&products_id=796)>.  
 Gear Base Pack—VEX Robotics, <http://www.vexrobotics.com/liq-gear-g.html>, Innovation First International, Inc. Copyright © 2002-2016.  
 Gearbox Front Sprocket, posted on [ebay.co.uk](http://ebay.co.uk), posted Nov. 29, 2016, no production date given, [online], [site visited May 11, 2017], Available from Internet, <URL: <http://www.ebay.co.uk/itm/NEW-Tag-Metals-MX-Honda-CR250R-88-07-CR500R-CRF450-Gearbox-Front-Sprocket-13T-/252592369100>>.

(56)

## References Cited

## OTHER PUBLICATIONS

Kawada Machine Cut Spur Gear, posted on ebay.com, no posted date given, no production date given, [online], [site visited May 18, 2017], Available from Internet, <URL: [http://www.ebay.com/itm/Kawada-Machine-Cut-Spur-Gear-64P-78T-1-10-RC-Cars-Touring-Drift-On-Road-SM6478-/142068863379?\\_trksid=p2385738.m2548.14275](http://www.ebay.com/itm/Kawada-Machine-Cut-Spur-Gear-64P-78T-1-10-RC-Cars-Touring-Drift-On-Road-SM6478-/142068863379?_trksid=p2385738.m2548.14275)>.

Makeblock, Gears Search—Makeblock Co., Ltd. (<http://www.makeblock.com>) <http://learn.makeblock.com/en/mechanical-parts/Gears> ©2013-2017 Makeblock Co., Ltd.

Makeblock, Sprocket Search—Makeblock Co., Ltd. (<http://www.makeblock.com>) <http://learn.makeblock.com/en/mechanical-parts/#Sprockets> ©2013-2017 Makeblock Co., Ltd.

Makeblock, Wheel Search—MakeBlock Co., Ltd (<http://www.makeblock.com>) <http://learn.makeblock.com/en/mechanical-parts/#Wheels> © 2013-2017 Makeblock Co., Ltd.

Martin Roller Chain Sprocket, posted on amazon.com, earliest review posted Nov. 18, 2012, no production date given, [online], [site visited May 11, 2017], Available from Internet, <URL: [https://www.amazon.com/Martin-Roller-Sprocket-Bored-Single/product-reviews/B004JXWH8C/ref=cm\\_cr\\_getr\\_d\\_paging\\_btm\\_3?ie=UTF8&reviewerType=avp\\_only\\_reviews&sortBy=r](https://www.amazon.com/Martin-Roller-Sprocket-Bored-Single/product-reviews/B004JXWH8C/ref=cm_cr_getr_d_paging_btm_3?ie=UTF8&reviewerType=avp_only_reviews&sortBy=r)>.

Modern Robotics, Gears Search—Modern Robotics, Inc. (<http://www.modernroboticsinc.com>) <http://www.modernroboticsinc.com/search?q=gear> © 2017 Modern Robotics, Inc.

Modern Robotics, Wheel Search—Modern Robotics Inc. (<https://www.modernroboticsinc.com>) <http://www.modernroboticsinc.com/search?q=wheel> © 2017 Modern Robotics Inc.

Pitsco Tetrax, Gears Search—Tetrax Robotics (<http://www.tetraxrobotics.com>) <http://www.tetraxrobotics.com/Search/gears?st=0> © 2017 Pitsco, Inc. (1 pg.).

Robinson Racing Spur Gear, 72T; NRU, TMX RRP8572, posted on amazon.com, earliest reviewed Jan. 19, 2015, no production date given, [online], [site visited May 18, 2017], Available from Internet, <URL: [https://www.amazon.com/Robinson-Racing-Steel-Spur-Gear/dp/B0006N6N7K/ref=sr\\_1\\_9?ie=UTF8&qid=1495154175&sr=8-9&keywords=spur+gear](https://www.amazon.com/Robinson-Racing-Steel-Spur-Gear/dp/B0006N6N7K/ref=sr_1_9?ie=UTF8&qid=1495154175&sr=8-9&keywords=spur+gear)>.

Roller chain sprockets and platewheels, posted fbchain.com, no posted date given, no production date given, [online], [site visited May 11, 2017], Available from Internet, <URL: <http://www.fbchain.com/sprockets>>.

Servocity Robotics, Gears Search—Servocity Robotics (<https://www.servocity.com>) <https://www.servocity.com/catalogsearch/result?q=Gears> © 1999-2016 Robotzone, LLC—ServoCity® is a registered trademark of Robotzone, LLC.

Servocity Robotics, Sprocket Search—Servocity Robotics (<https://www.servocity.com>) <https://www.servocity.com/catalogsearch/result?q=Sprocket> © 1999-2016 Robotzone, LLC—ServoCity® is a registered trademark of Robotzone, LLC.

Servocity Robotics, Wheel Search—Servocity Robotics (<https://www.servocity.com>) <https://www.servocity.com/catalogsearch/result?q=wheel> © 1999-2016 Robotzone, LLC, ServoCity® is a registered trademark of Robotzone, LLC.

SparkFun Electronics Gears Search—SparkFun Electronics (<https://www.sparkfun.com>) <https://www.sparkfun.com/search/results?term=gears> (Publication date unknown but assumed to be prior to filed.).

SparkFun Electronics Sprocket Search—SparkFun Electronics (<https://www.sparkfun.com>) <https://www.sparkfun.com/search/results?term=sprocket> (Publication date unknown but assumed to be prior to the filed.).

SparkFun Electronics Wheel Search—SparkFun Electronics (<https://www.sparkfun.com>) <https://www.sparkfun.com/search/results?term=wheel> (Publication date unknown but assumed to be prior to the filed.).

Sprocket Hub Gear Guard Kit, posted on ebay.com, no posted date given, no production date given, [online], [site visited May 11, 2017], Available from Internet, <URL: <http://www.ebay.com/itm/191673594110?rmvSB=true>>.

Sprockets & Chain—VEX Robotics, <http://vexrobotics.com/sprockets-and-chain.html>, Innovation First International, Inc. © 2002-2016. Sprockets & Chain Kit—VEX Wiki, [https://www.vexrobotics.com/wild/Sprocket\\_and\\_Chain\\_Kit](https://www.vexrobotics.com/wild/Sprocket_and_Chain_Kit), Innovation First International, Inc. © 2002-2016.

Tetrax Pitsco Wheel Search—Pitsco Inc. (<http://www.servocity.com>) <http://www.tetraxrobotics.com/Search/wheel?st=0> © 2017 Pitsco, Inc.

Tsubaki Sprockets, posted on frasers.com, no posted date given, no production date given [online], [site visited May 11, 2017], Available from Internet, <URL: <http://www.frasers.com/supplier/tsubaki-of-canada-ltd-16573675102/product-category/chain-sprockets-10647377260>>.

United 22mm Spline Drive Metro Sprocket, posted on acebm.com, posted Sep. 17, 2013, no production date given, [online], [site visited May 11, 2017], Available from Internet, <URL: <http://www.acebm.com/sprockets-bmx-c-60/united-22mm-spline-drive-metro-sprocket-p-3633.html>>.

Vex Pro Gears—VEX Robotics (<https://www.vexrobotics.com/vexpro>) <https://www.vexrobotics.com/vexpro/motion/vexpro-gears> © 2002-2017, VEX Robotics, Inc. is a subsidiary of Innovation First International, Inc.

Vex Robotics Gears Search—Vex Robotics (<https://www.vexrobotics.com>) <https://www.vexrobotics.com/catalogsearch/result?q=gears> ©2002-2017. Vex Robotics, Inc. is a subsidiary of Innovation First International, Inc.

Vex Robotics Sprocket Search—Vex Robotics, Inc. (<https://www.vexrobotics.com>) <https://www.vexrobotics.com/catalogsearch/result?q=sprocket>.

Vex Robotics Wheel Search—Vex Robotics (<https://www.vexrobotics.com>) <https://www.vexrobotics.com/catalogsearch/result?q=wheel> © 2002-2017. VEX Robotics, Inc. is a subsidiary of Innovation First International, Inc.

U.S. Appl. No. 29/553,527, Karol et al., filed Feb. 2, 2016.

U.S. Appl. No. 29/572,420, Karol et al., filed Jul. 27, 2016.

U.S. Appl. No. 29/572,423, Karol et al., filed Jul. 27, 2016.

U.S. Appl. No. 15/419,882, Karol et al., filed Jan. 30, 2017.

U.S. Appl. No. 29/629,982, Karol et al., filed Dec. 18, 2017.

U.S. Appl. No. 29/629,983, Karol et al., filed Dec. 18, 2017.

U.S. Appl. No. 29/645,161, Karol et al., filed Apr. 24, 2018.

U.S. Appl. No. 29/646,704, Karol et al., filed May 7, 2018.

U.S. Appl. No. 29/657,871, Karol et al., filed Jul. 26, 2018.

U.S. Appl. No. 29/572,419, Karol et al., filed Jul. 27, 2018.

U.S. Appl. No. 29/657,798, Karol et al., filed Jul. 25, 2018.

U.S. Appl. No. 29/661,815, Hunt et al., filed Aug. 30, 2018.

\* cited by examiner

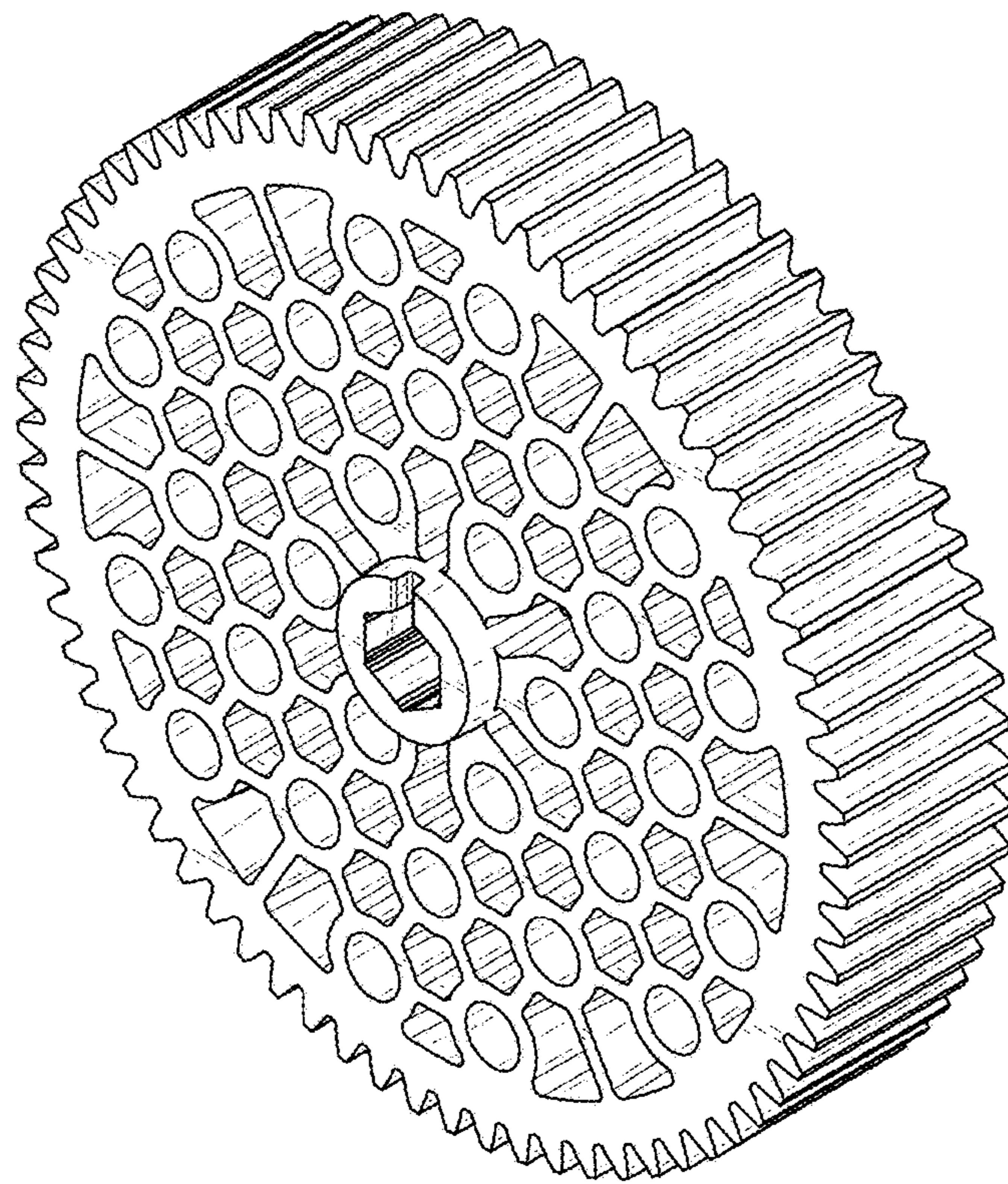

FIG. 1

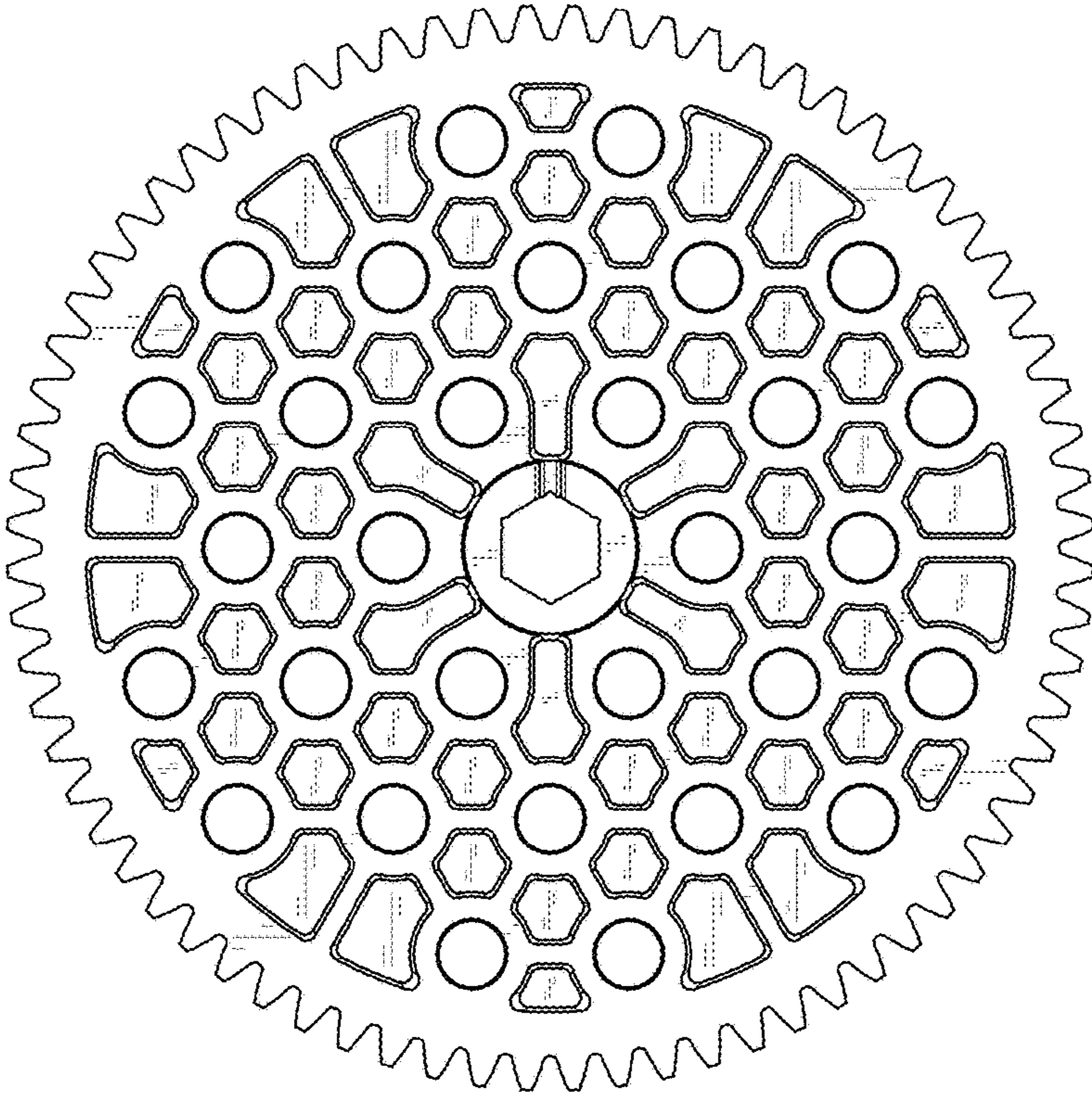

FIG. 2

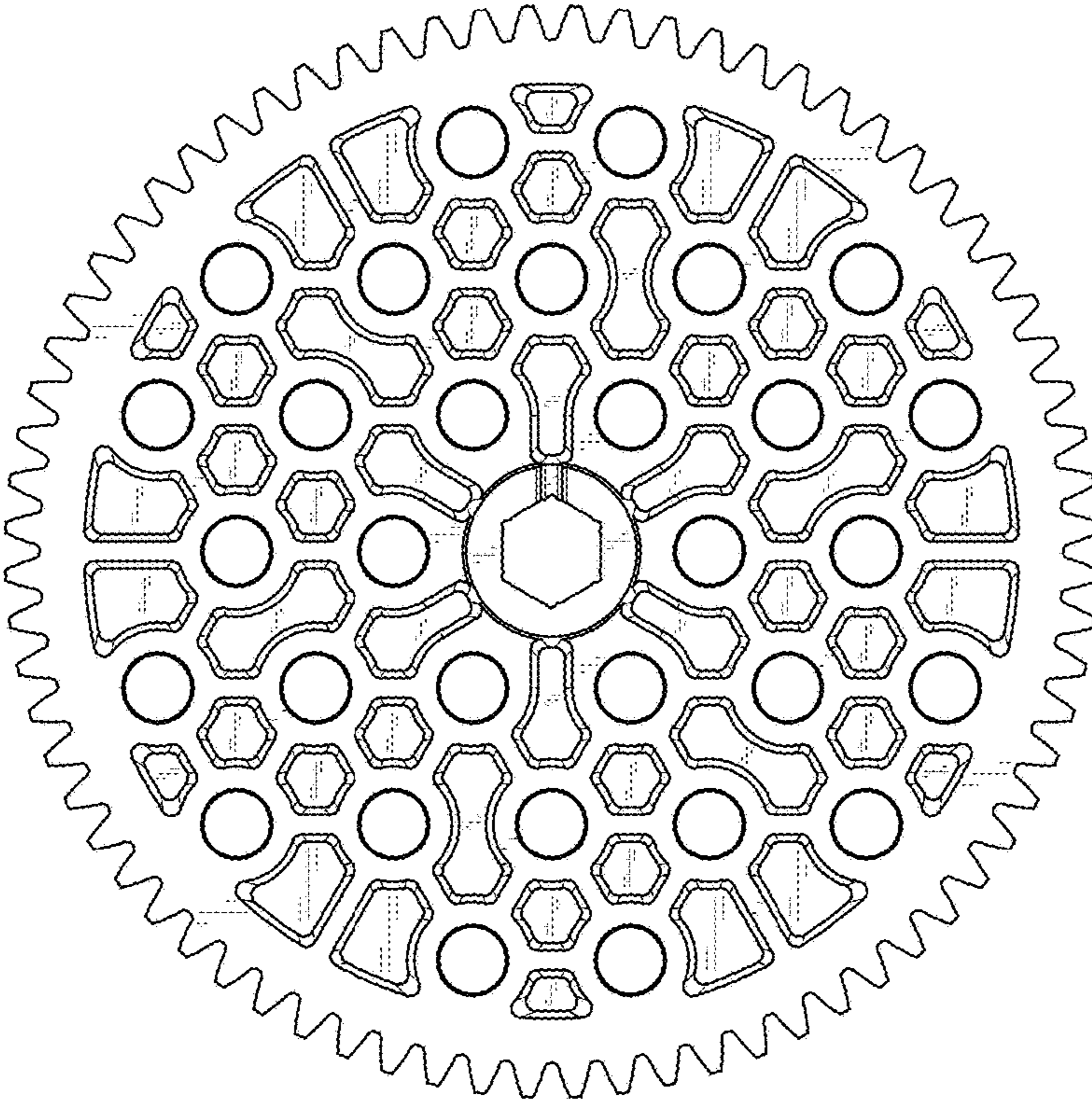

FIG. 3

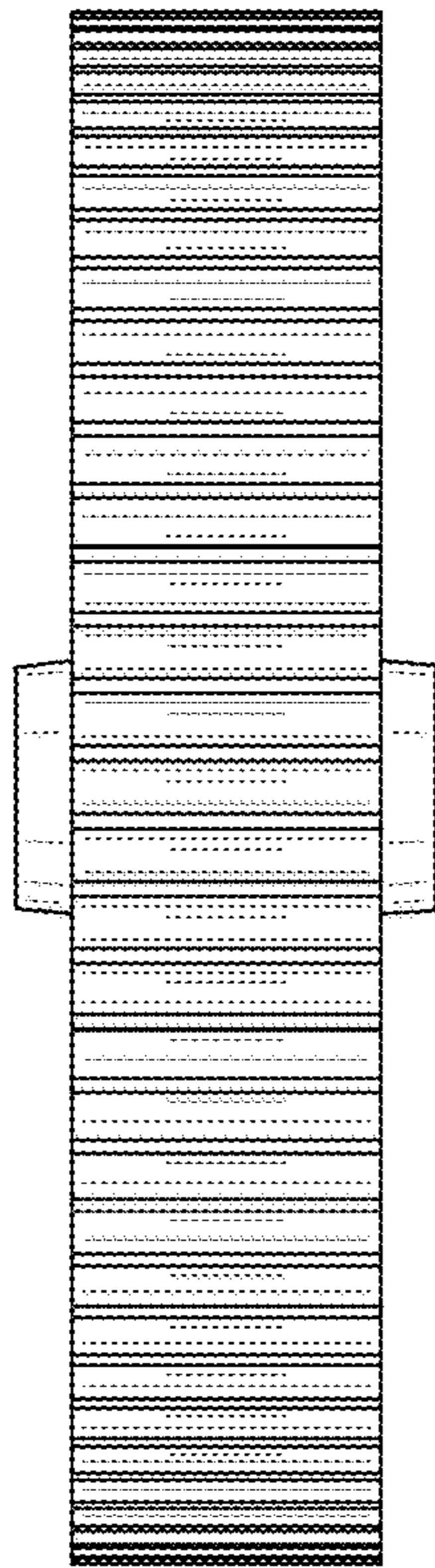

FIG. 4

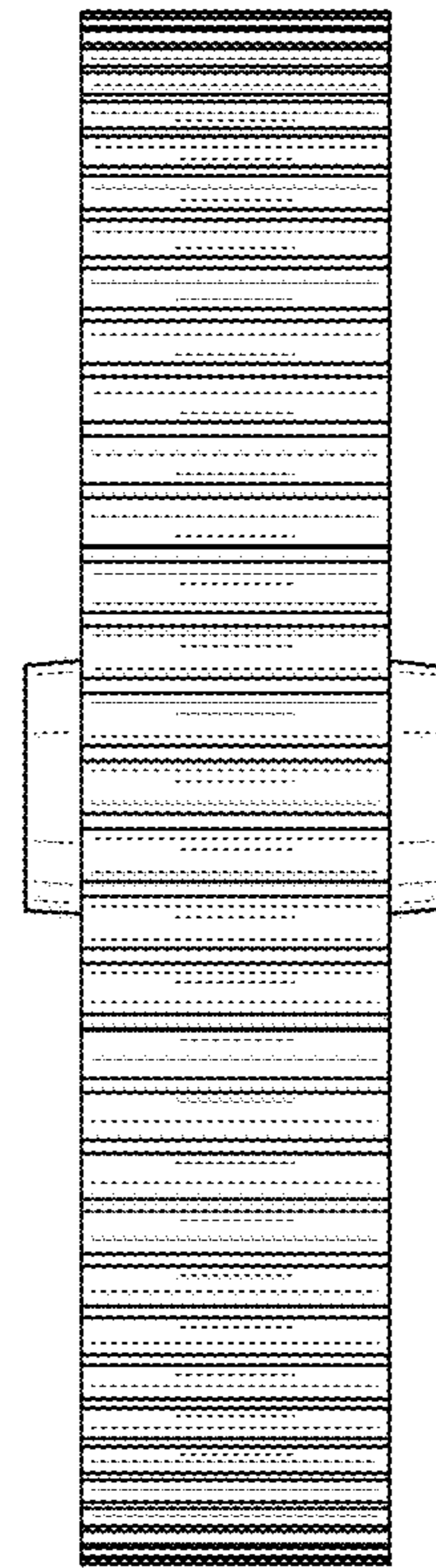

FIG. 5

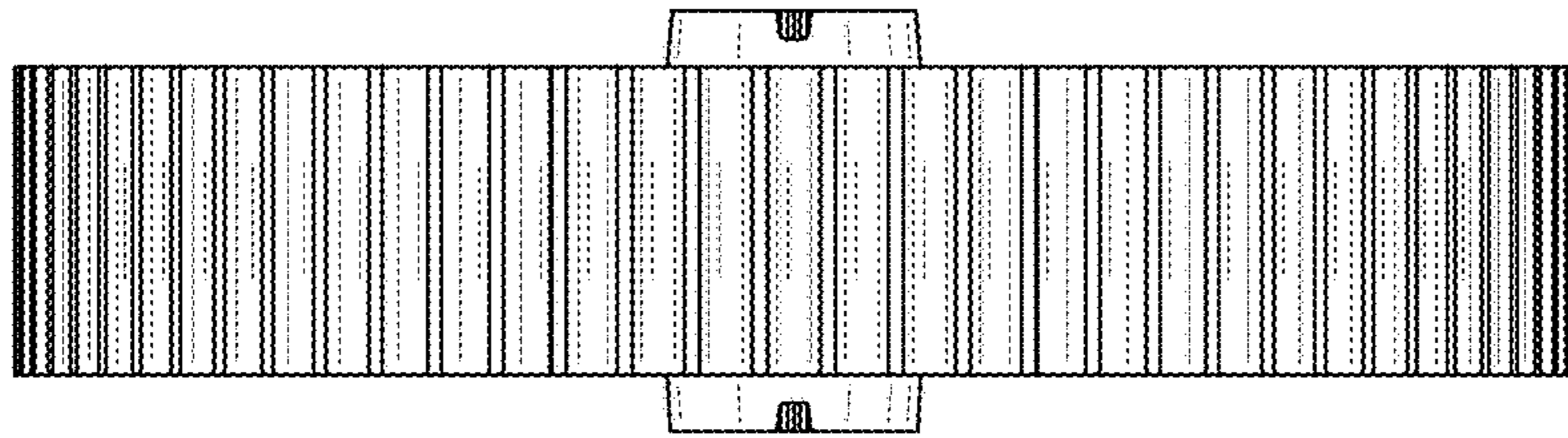

FIG. 6

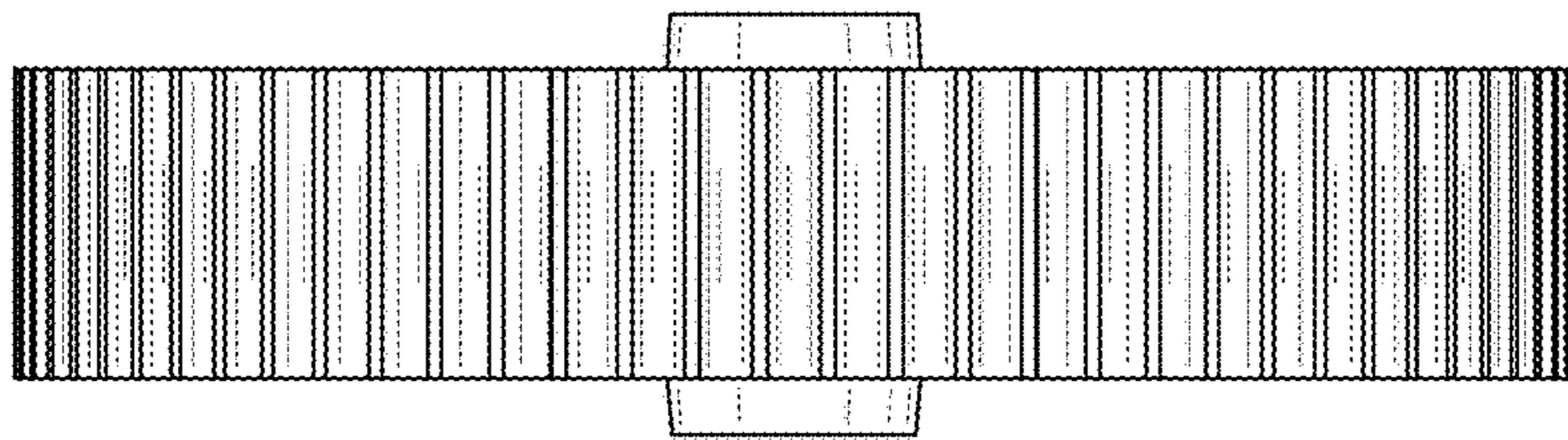

FIG. 7