



US00D881766S

(12) **United States Design Patent** (10) **Patent No.:** **US D881,766 S**
Canepa et al. (45) **Date of Patent:** **** Apr. 21, 2020**

- (54) **HANDLEBAR FOR CYCLES OR MOTORCYCLES**
- (71) Applicant: **PIAGGIO & C S.p.A.**, Pontedera (IT)
- (72) Inventors: **Marco Canepa**, Pontedera (IT); **Marco Lambri**, Pontadera (IT)
- (73) Assignee: **PIAGGIO & C. S.P.A.**, Pontedera (Pisa) (IT)
- (**) Term: **15 Years**
- (21) Appl. No.: **29/668,532**
- (22) Filed: **Oct. 31, 2018**

Related U.S. Application Data

- (62) Division of application No. 29/602,662, filed on May 2, 2017, now Pat. No. Des. 847,710.

Foreign Application Priority Data

- Nov. 4, 2016 (EM) 003447937
- (51) **LOC (12) Cl.** **12-11**
- (52) **U.S. Cl.**
USPC **D12/178**
- (58) **Field of Classification Search**
USPC D12/111, 114, 178; D8/303
CPC B62K 19/16; B62K 21/12; B62K 21/18;
B62K 21/125; B62K 23/06
See application file for complete search history.

- (56) **References Cited**
U.S. PATENT DOCUMENTS
- 6,249,744 B1 * 6/2001 Morita G01C 21/265
701/487
- D450,278 S * 11/2001 Solberg D12/178
- D519,911 S * 5/2006 Mah D12/317
- D637,545 S * 5/2011 Cote D12/317
- D654,411 S * 2/2012 Alt D12/178
- D691,527 S * 10/2013 Thorpe D12/178
- D719,894 S * 12/2014 Akita D12/307
- D738,276 S * 9/2015 Arbour D12/178
- D817,237 S * 5/2018 Talios D12/178

* cited by examiner

Primary Examiner — Darlington Ly
(74) *Attorney, Agent, or Firm* — Cantor Colburn LLP

(57) **CLAIM**

The ornamental design for a handlebar for cycles or motorcycles, as shown and described.

DESCRIPTION

FIG. 1 is a top, rear, and right side perspective view of a handlebar for cycles or motorcycles showing our new design;
FIG. 2 is a front elevation view thereof;
FIG. 3 is a rear elevation view thereof;
FIG. 4 is a right side elevation view thereof;
FIG. 5 is a top plan view thereof; and,
FIG. 6 is a bottom plan view thereof.

1 Claim, 6 Drawing Sheets

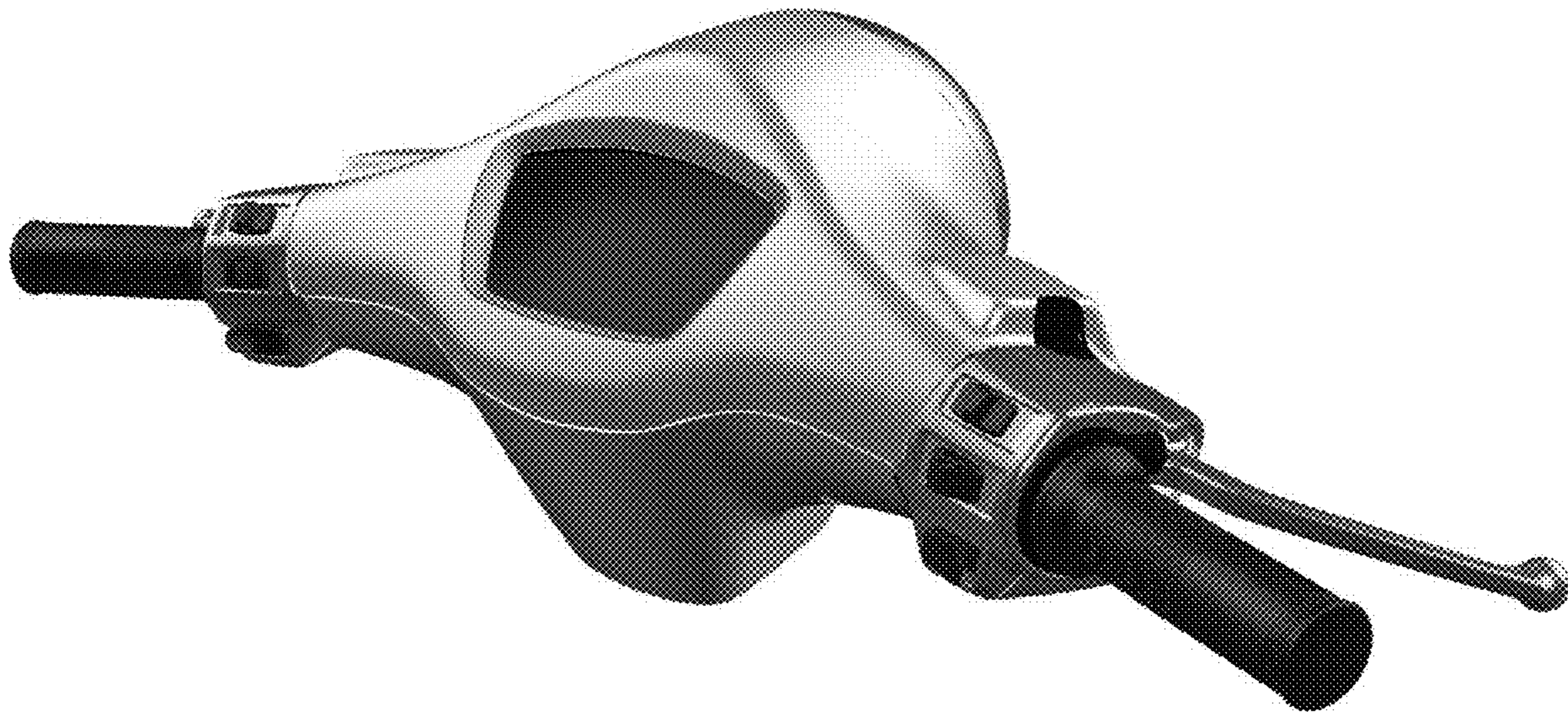

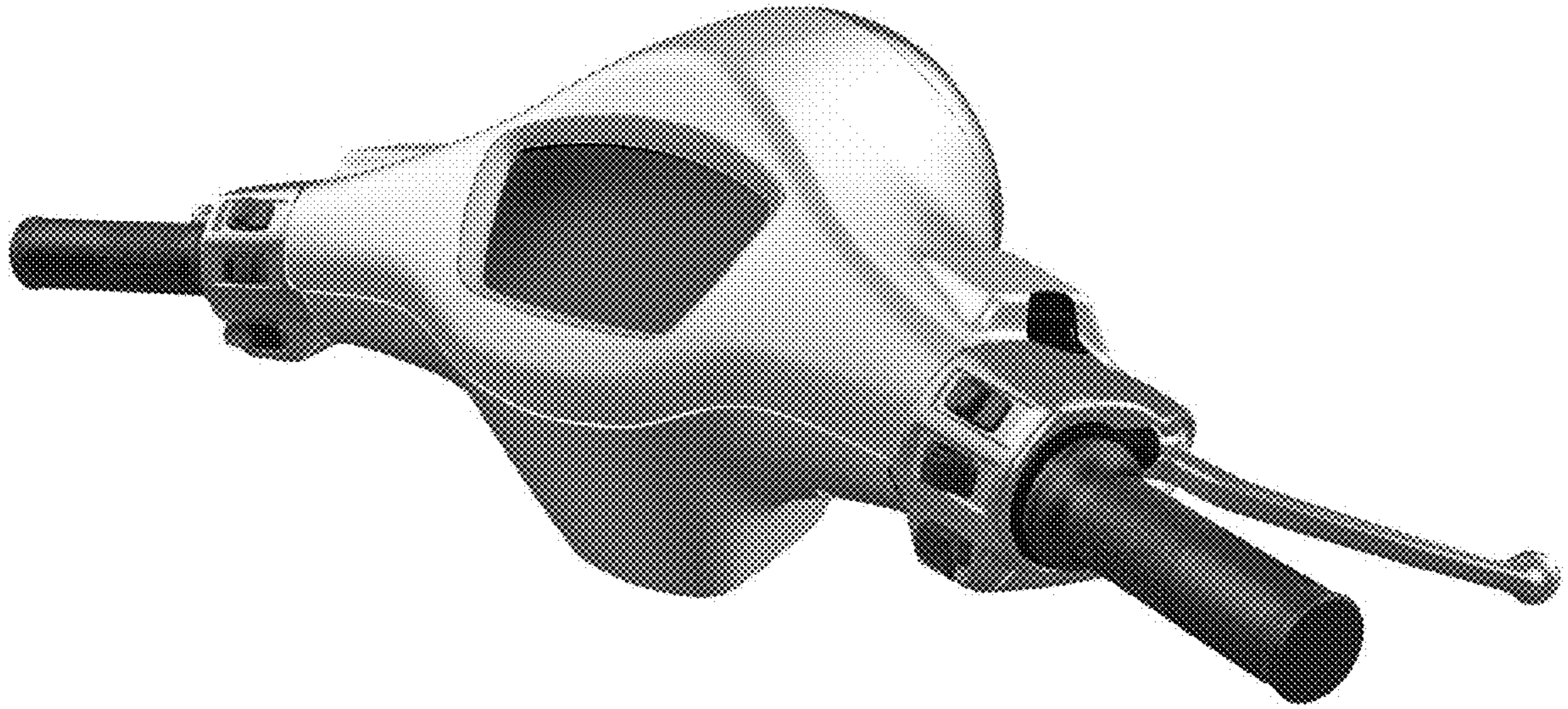

FIG. 1

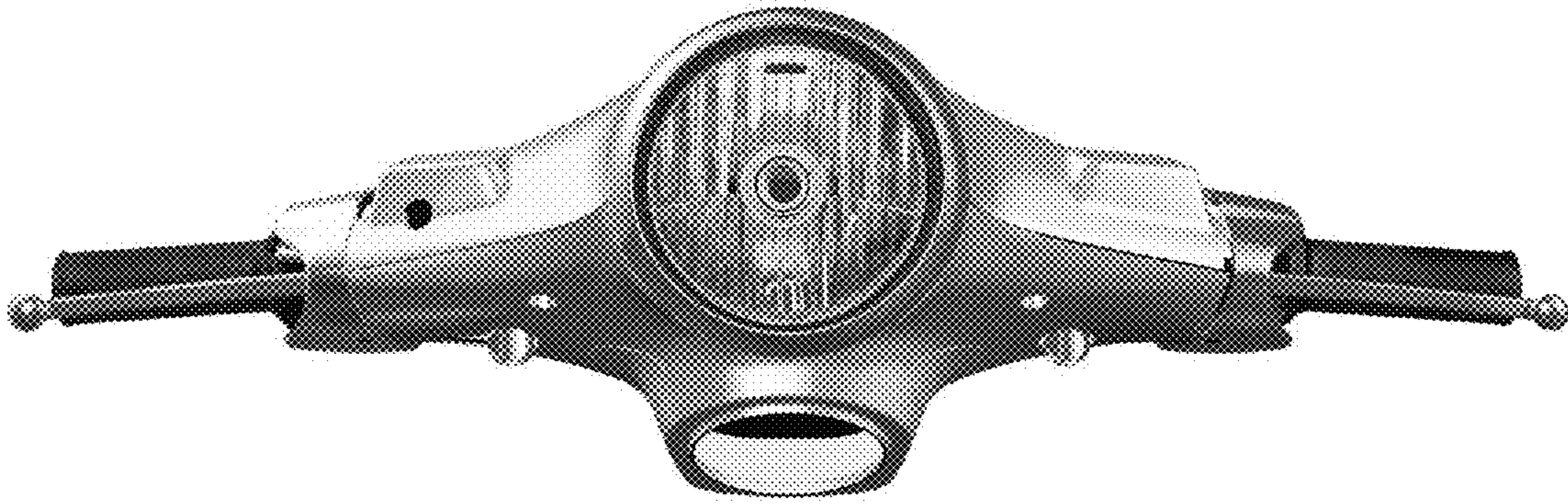

FIG. 2

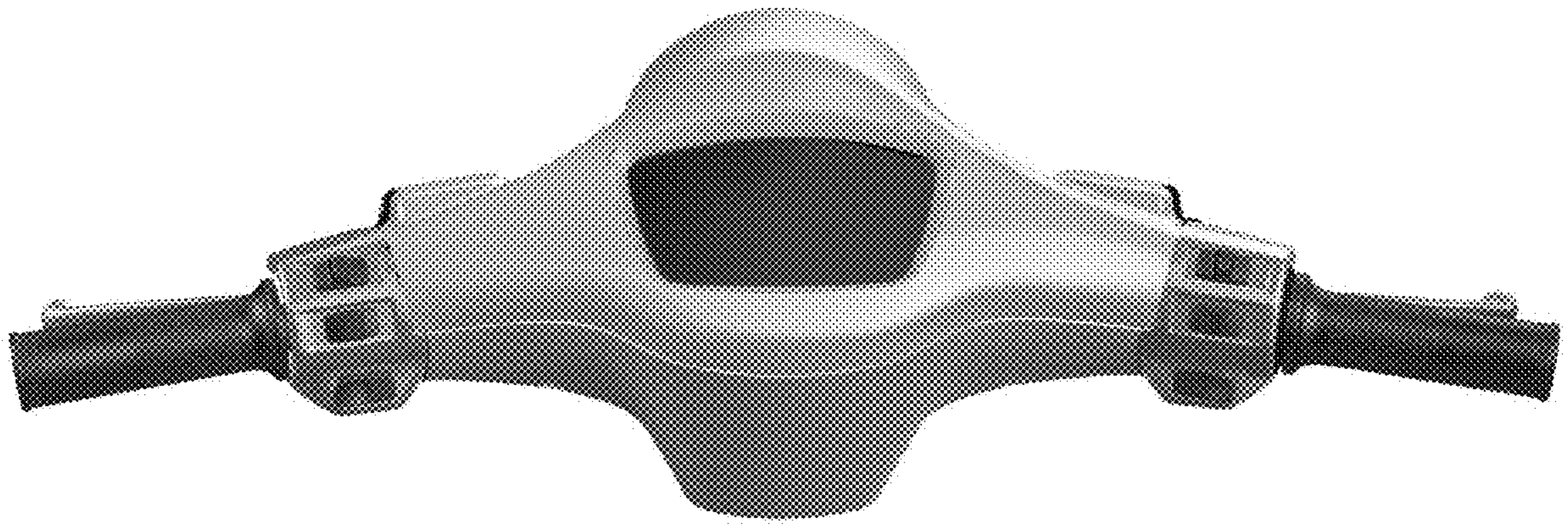

FIG. 3

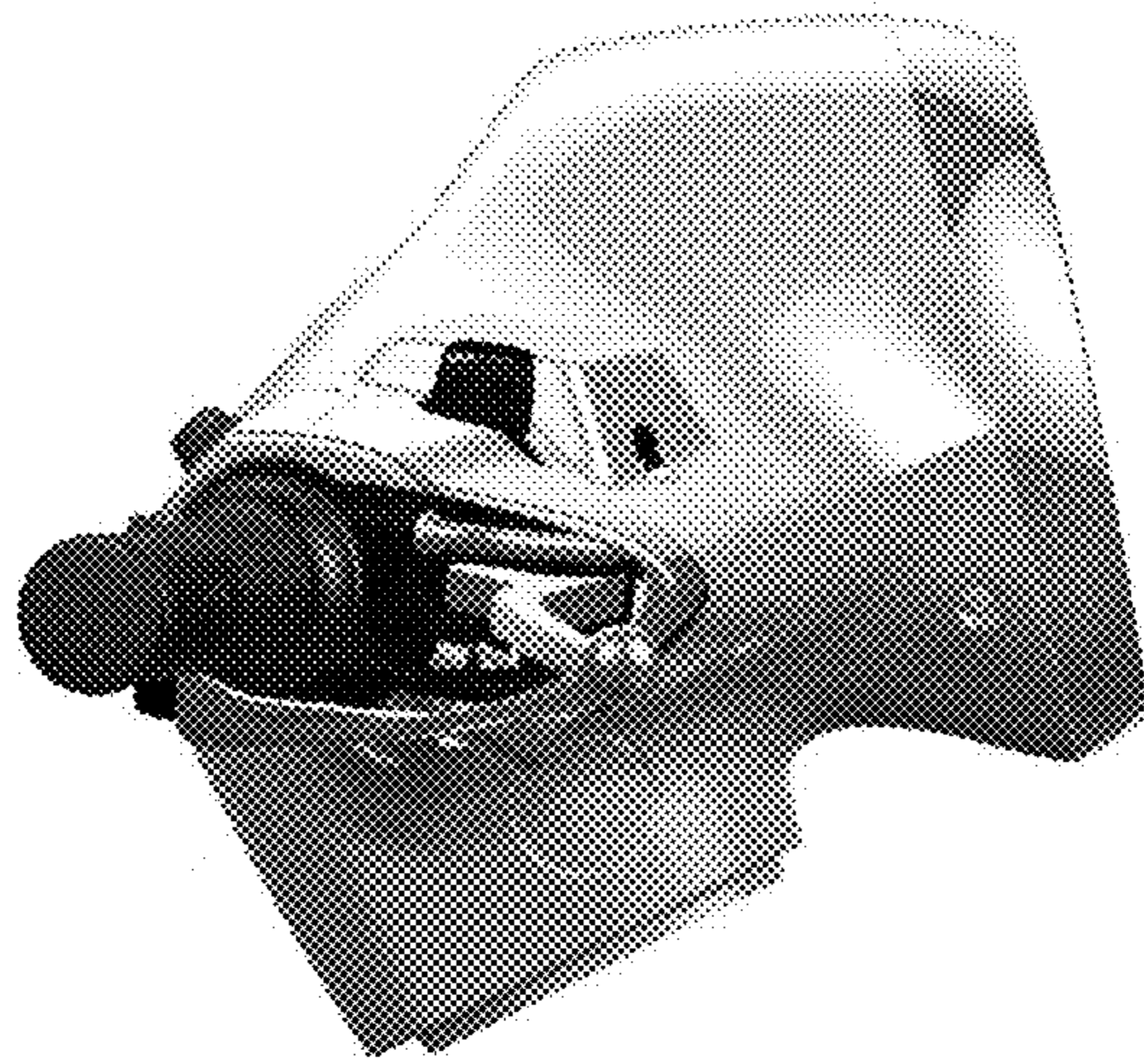

FIG. 4

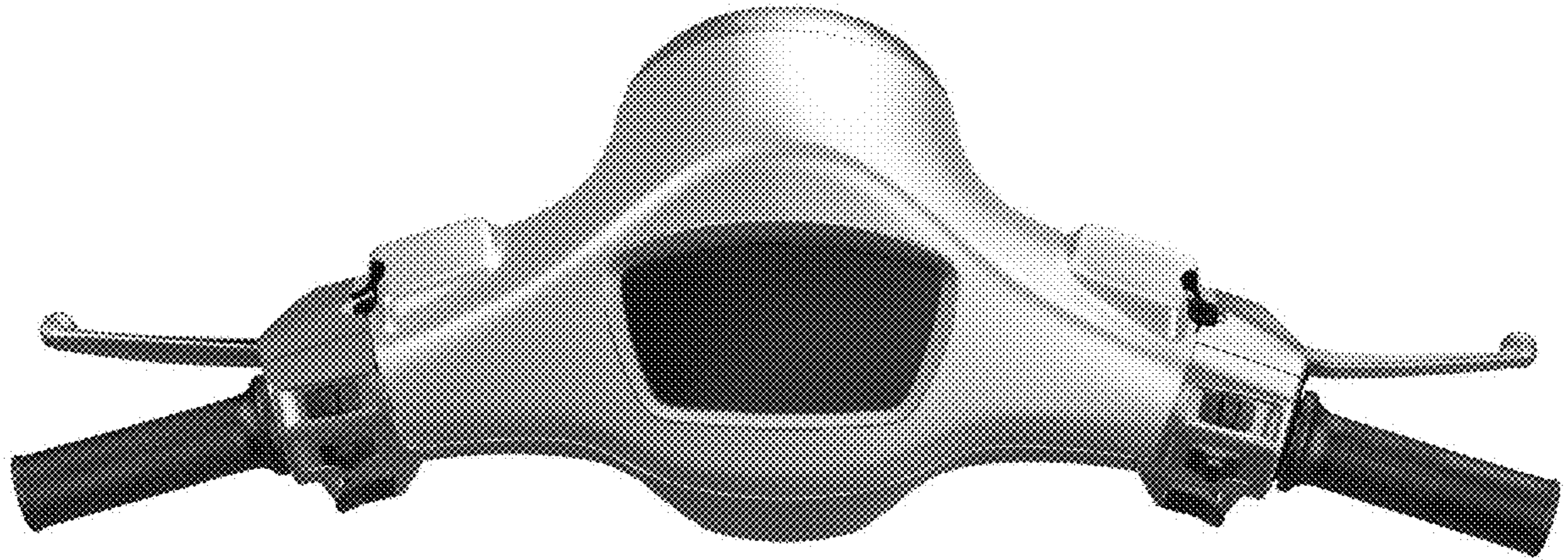

FIG. 5

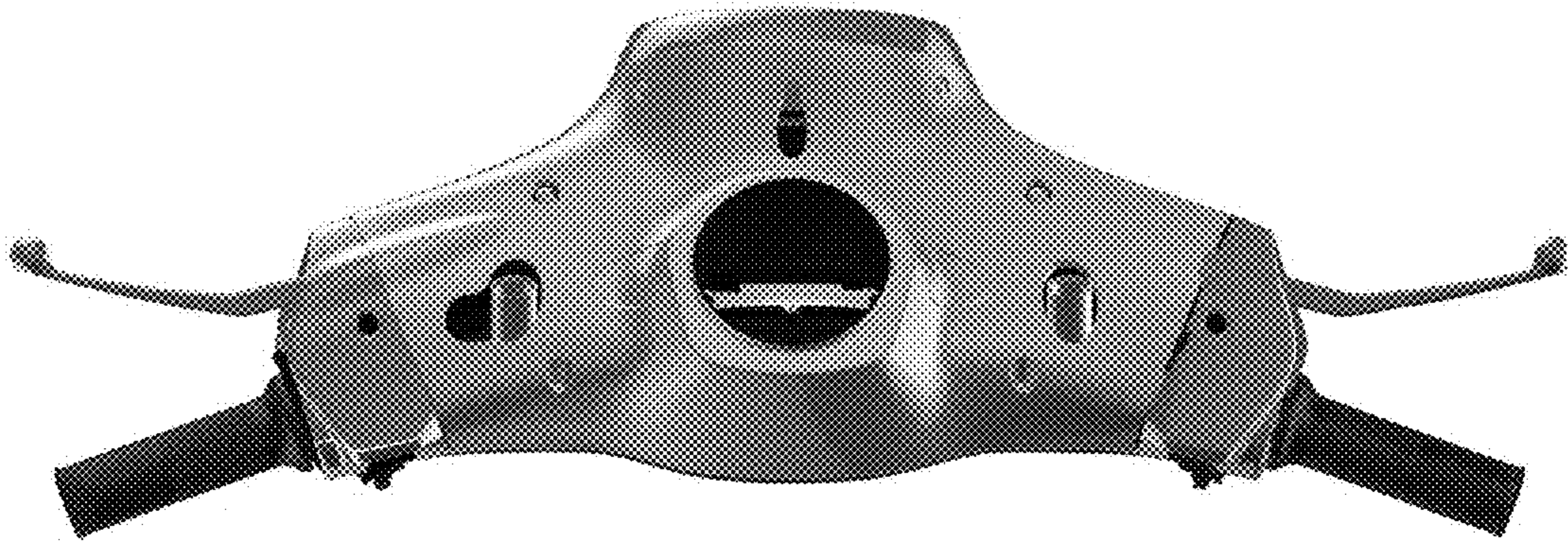

FIG. 6